

# Airflex® FHB Brake Elements

## Section E

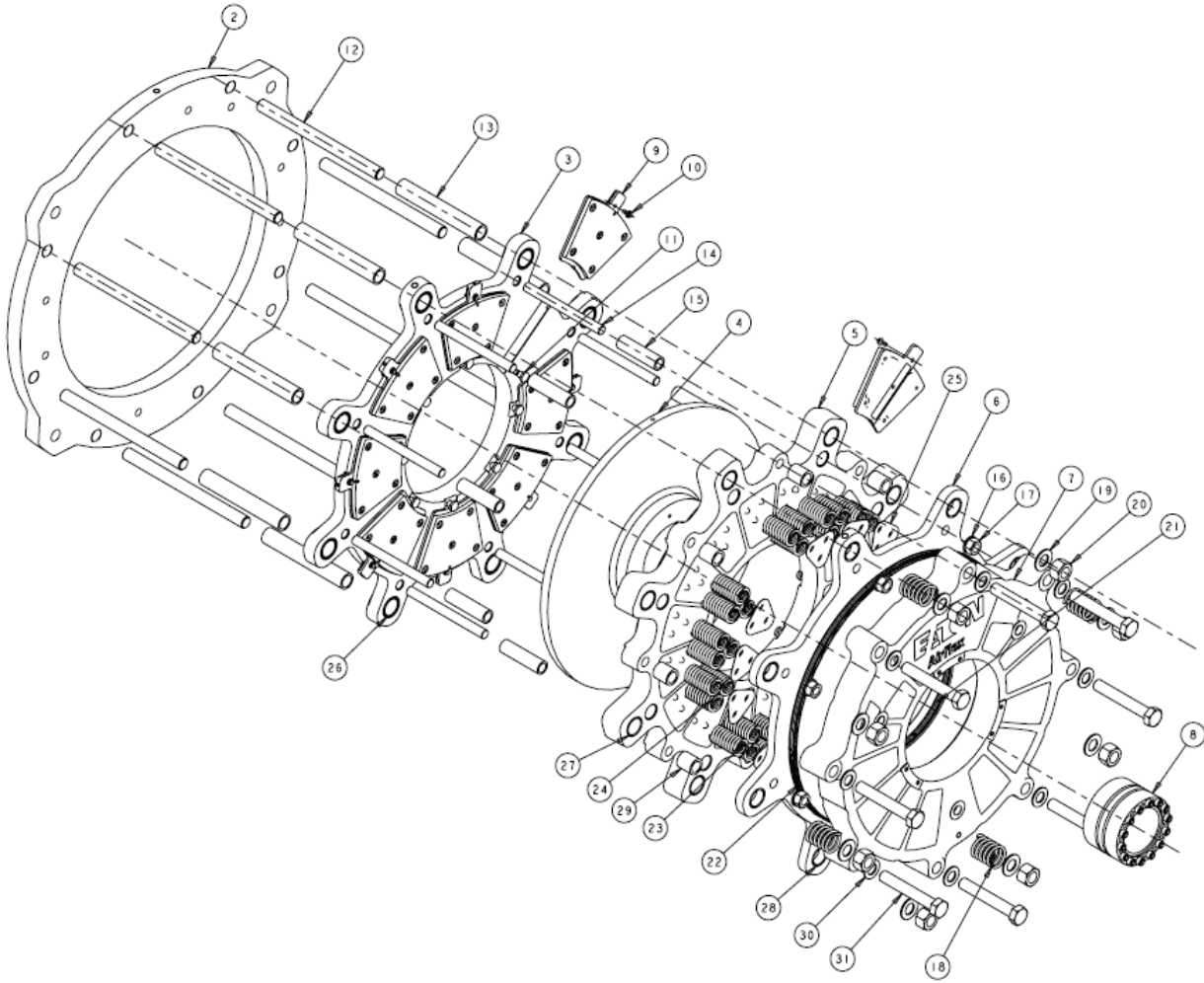

### Typical Applications

Item	Qty.	Description	Part Number
*2	1	Mounting Flang	515532
3	1	Floating Plate	515503
*4	1	Disc	515536
5	1	Pressure Plate	515505
6	1	Spring Housing	515507
7	1	Cylinder	515509
*8	1	B-Loc	417385-02
9	16	Friction Lining S/A	308589
10	16	Flanged Bolt	308602
11	16	Metric Shoulder Screw	308593
12	8	Main Stud	308601-01
13	8	Clamp Tube	308586-01
14	8	Support Stud	308592-01
15	8	Spacer	308590-01
16	8	Plain Washer	000067X0063

### Typical Applications

Item	Qty.	Description	Part Number
17	8	Nut	000414X0013
18	4	Return Spring	416751-04
19	8	Plain Washer	000067X0065
20	8	Nut	000414X0004
21	2	Lip Seal	000402X0005
22	2	Lip Seal	000402X0006
**23	36	Inner Apply Spring	416751-08
**24	36	Outer Apply Spring	416751-07
25	12	Spring Retainer	415635
26	8	FP Bush	204214-01
27	8	PP Bush	204214-02
28	8	SH Bush	204214-03
29	8	Power Head Spacer	308599-01
30	8	Plain Washer	000067X0064
31	8	Screw	000391X3602

\*Part number may vary - depending on application

\*\*Quantity may vary - depending on application requirements