



Twiflex

Ameridrives

Wichita Clutch

Bibby Turboflex

Svendborg Brakes

Turning, Locking, & Braking Systems for Marine Propulsion

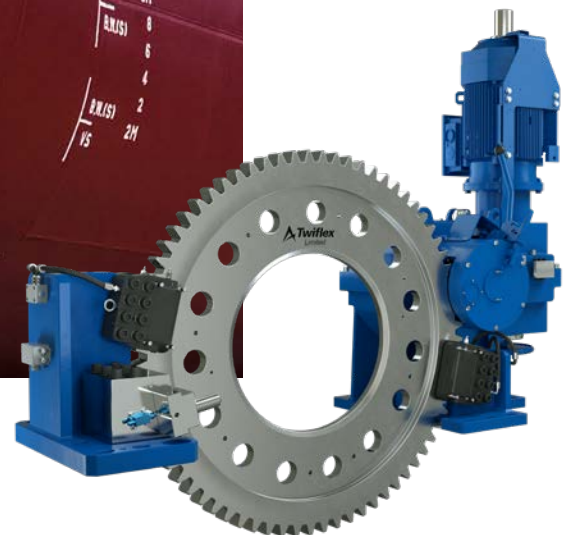

Couplings, Clutches & Brakes

Ameridrives • Bibby Turboflex • Formsprag Clutch • Guardian Couplings
Huco • Industrial Clutch • Lamiflex Couplings • Marland Clutch • Stieber Clutch
Stromag • Svendborg Brakes • TB Wood's • Twiflex • Wichita Clutch

ALTRA INDUSTRIAL MOTION PROVIDES POWER TRANSMISSION SOLUTIONS FOR THE MARINE MARKET

As a leading multinational designer and producer of a wide range of electromechanical power transmission equipment, Altra offers products for marine applications where reliability and accuracy are necessary to avoid costly downtime, assure safe operation and consistent performance.

With a full complement of products for the marine market such as clutches, brakes, couplings, gearing, geared motors, and linear actuators, the Altra brands have supported many prominent marine customers for years by providing decades of marine market expertise in a variety of marine applications such as deck machinery (various winches and crane/hoist systems), propulsion systems and auxiliary drives (such as dredge pumps, jet pumps, cutter heads and generator drives).



Altra brands are able to supply products to meet requirements of marine societies including: Lloyds Register of Shipping (LRS), Germanischer Lloyd, Chinese Classification Society, American Bureau of Shipping (ABS), Det Norske Veritas (DNV) Bureau Veritas, RINA (Italian), Russian Register, and Nippon Kaiji Kentei Kyoukai (NK).

www.AltraMotion.com www.Altra-Marine.com

THESE ALTRA BRANDS HAVE SIGNIFICANT EXPERIENCE IN MARINE APPLICATIONS:

 **Twiflex®**
Altra Industrial Motion

 **Bibby Turboflex®**
Altra Industrial Motion

 **Ameridrives®**
Altra Industrial Motion

 **Svendborg Brakes®**
Altra Industrial Motion

 **Wichita Clutch®**
Altra Industrial Motion

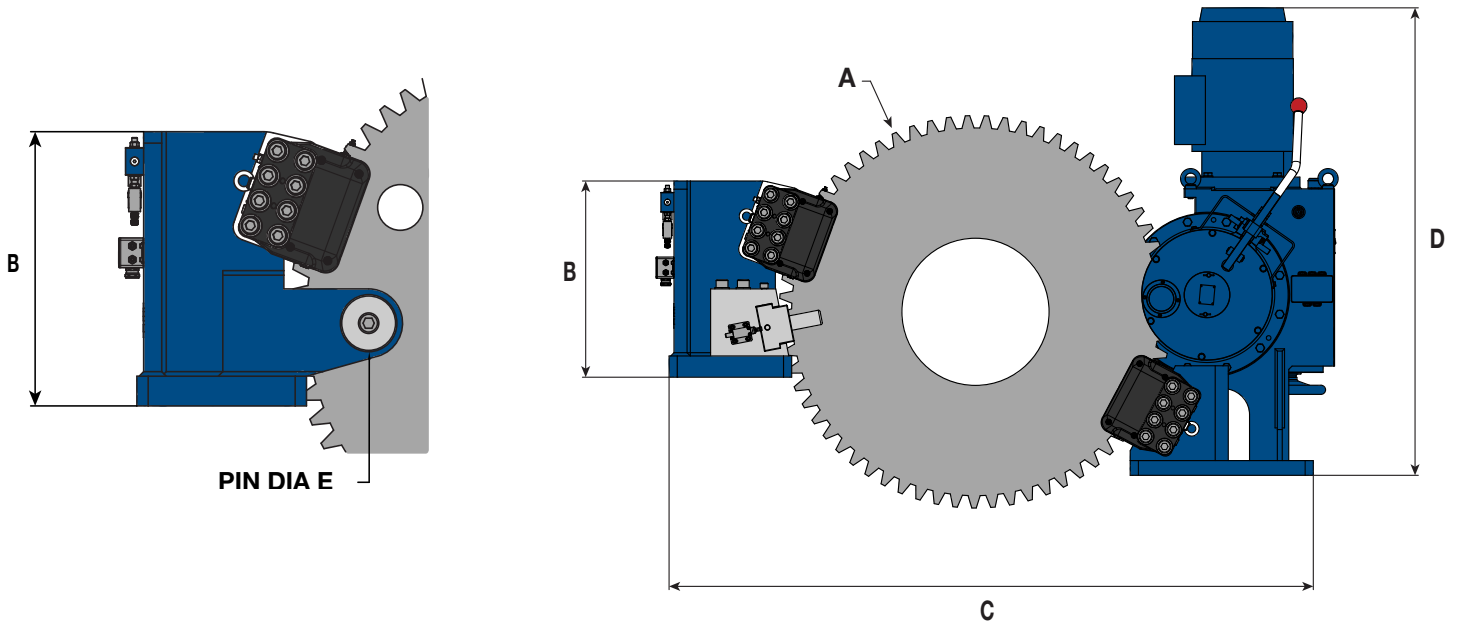

Dimension	TLB80-C	TLB120-C	TLB150-C	TLB200-C	TLB230-C
A	32	48	60	80	92
B	20	24	24	24	24
C	54	80	106	138	148
D	48	58	78	78	78
E	3	4	4	4	6

All dimensions shown in inches

LOCKING DEVICES

- Axial pin or tooth options to suit different disc sizes
- Manually operated as standard, hydraulic and mechanical options upon request
- Engineered custom solutions and status monitoring can be provided



Turning, Locking & Braking Systems
by Twiflex

WHY MARINE CUSTOMERS CHOOSE ALTRA

A SUPERIOR SOLUTION – LOCAL SUPPORT AROUND THE WORLD

The Altra Marine Technology family provides local sales and service support with global R&D capabilities and production facilities in Europe, North America, South America and Asia Pacific.

- Proven high quality
- Local sales support globally
- Global R&D and testing facilities
- 22 leading PT brands
- Marine service capability
- Long employee retention
- Extensive marine application expertise
- Global engineering centers
- Marine certified
- Local stocking
- Strategic global sourcing
- Production in EU, NA, SA & AP
- Significant PT technical experiences

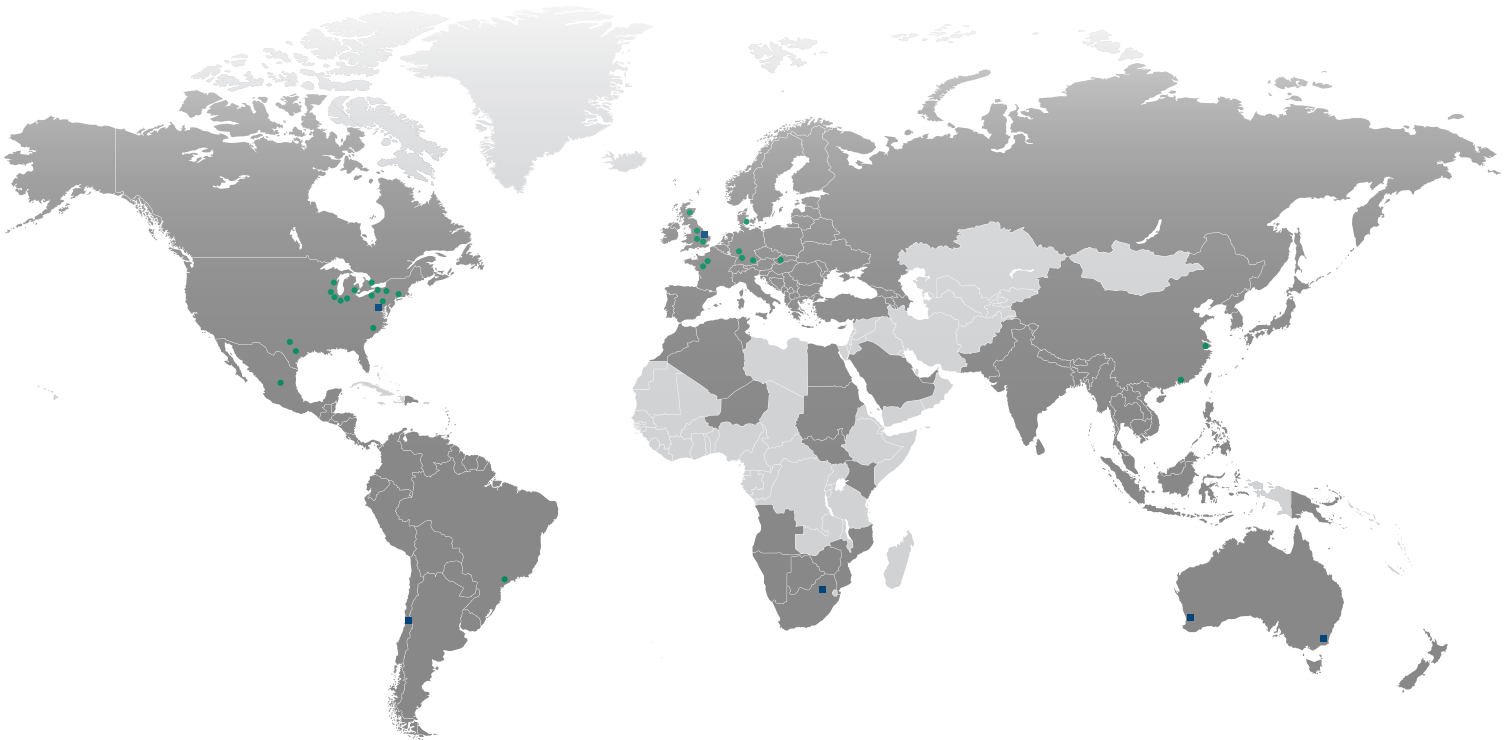

■ Sales Coverage | ● Altra Manufacturing Facilities | ■ Light Manufacturing & Assembly Center

Podded or Azimuth Thruster Brakes

Twiflex & Svendborg Brakes

Scissor caliper and modular brake solutions for podded and azimuth drives.

Wide range of pneumatic thruster and direct hydraulic pressure applied options available with braking forces up to 110,160 lbf.

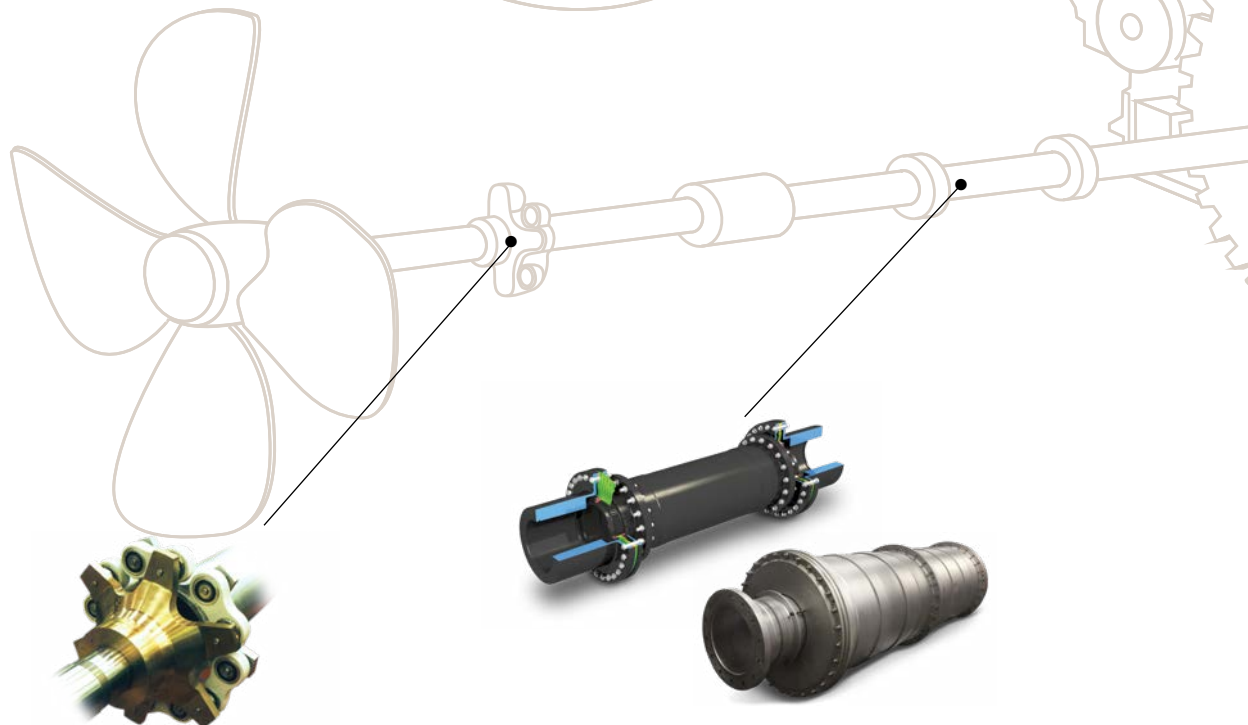
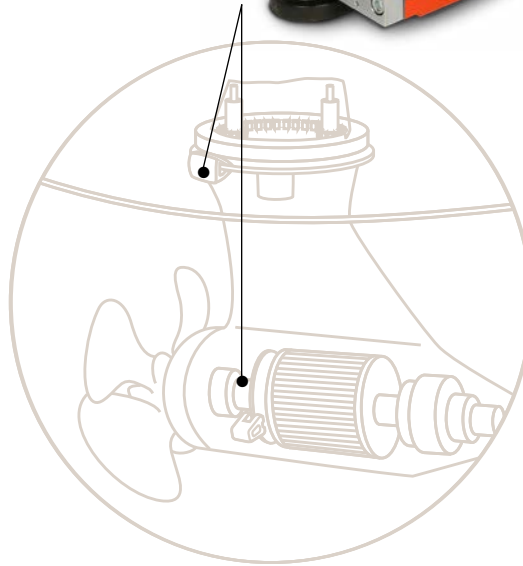

Laylink Coupling

Twiflex

Unique flexible link-coupling to accommodate shaft misalignment. High shock resistance, non-magnetic and good sound attenuation properties.

Shaft Couplings

Ameridrives & Bibby Turboflex

Custom design, light-weight couplings, capable of transmitting high torques at high speeds while accepting significant angular, radial and axial misalignment. High speed couplings for turbine driven water jets.

Shaft Turning, Locking & Braking

Twiflex

Integrated shaft turning and braking system with locking device. Turning torques in excess of 334,850 lb-ft. Braking and locking torques up to 635,780 lb-ft based on the standard range. Optional local controls and split drive gear/disc.

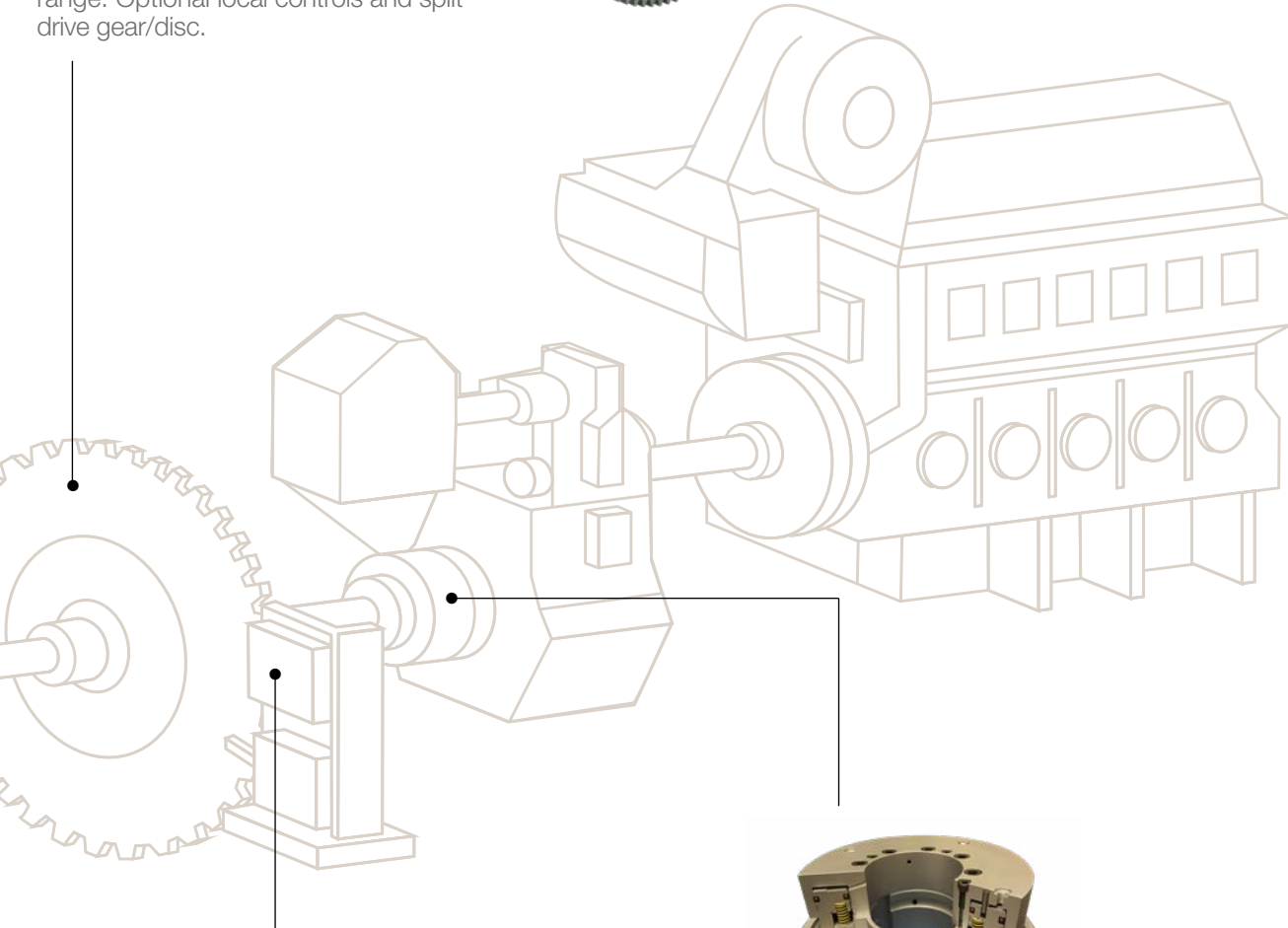
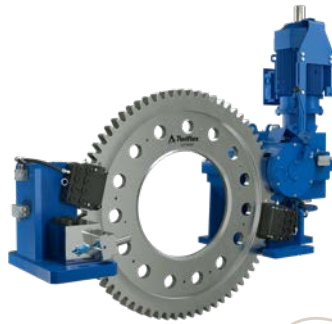

Oil-Immersed Clutches & Brakes

Wichita Clutch

Compact forced oil-cooled clutch and brake units for in-gearbox installation. High torque and power handling capability to suit a wide range of propulsion and PTO applications.

Optional unique seal key arrangement to simplify the clutch fitting process.

Torque capacities up to 106,210 lb-ft.

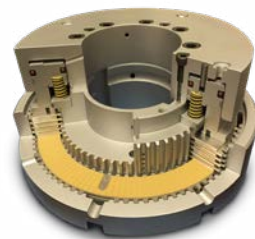

Direct Applied, Hydraulic or Pneumatic, Fixed or Floating Shaft Brakes

Twiflex & Svendborg Brakes

Direct (pressure applied) caliper brakes for dynamic shaft stopping and holding. Compact floating solutions for limited space and axial shaft movement. Braking forces up to 110,160 lbf.

TURNING, LOCKING AND BRAKING IN MARINE PROPULSION SYSTEMS



The Twiflex system comprises a Turning gear, Locking device, and shaft Brake (TLB) together with a power unit (e.g. Hydraulic Powerpack) and a control panel for local operation of the system close to the equipment. TLB is available as a continuous turning option as shown or as an indexing system using a simple hydraulic 'push-pull' arrangement with the brakes and brake disc to incrementally inch the propeller shaft for maintenance and accurate alignment. For a more cost effective solution, a simple manual option is also available for this purpose.

TURNING

TURNING: Low power turning while in port

BEARING CONDITIONING: Eliminates bearing damage due to setting when vessel is moored in port for extended periods

SHAFT ROTATION: Enables shaft rotation during installation and maintenance

POSITIONING: Optimizes propeller blade positioning while at sea and during maintenance and installation

ROTATION: Provides the ability to rotate the shaft when drive is disengaged

INSTALLATION: Quicker and easier installation and setting of drive components

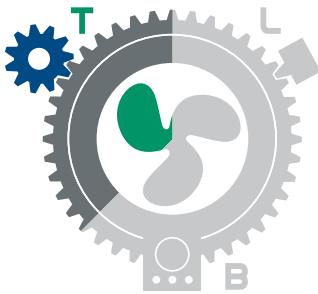

LOCKING

INCREASED SAFETY: Enables locking of the shaft for maintenance

IMPROVED FUEL EFFICIENCY: Used to lock shaft to prevent a wind milling effect while in operation (twin or multiple screw)

SHAFT LINE PROTECTION: Used to protect redundant or damaged shaft line while at sea

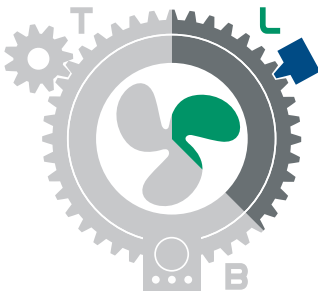

BRAKING

FASTER DIRECTIONAL CHANGES: Used to shorten stopping of rotating shaft or in order to change direction

- Improved maneuverability (twin or multiple screw) allowing better steering for rapid directional change
- Crash astern and crash stop

REDUCE LOAD ON PROPULSION SYSTEMS: used to shorten stopping of rotating shaft when coming into port

- Controlled stopping to protect drive components including gearbox when lubrication system has failed

PREVENT WIND MILLING EFFECT: Shaft holding when unpowered propeller rotates due to the flow stream

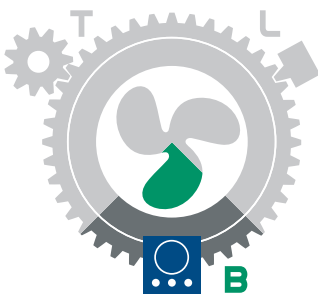

BENEFITS OF A COMPLETE INTEGRATED SYSTEM

When purchasing a complete turning gear system integrated with locking and braking from Twiflex, customers can consolidate three separate interfaces into one multi-functional solution: Turning 'T', Locking 'L', and Braking 'B', which enables customers to save dimensional space, decrease installation and maintenance time and reduce costs!

TWIFLEX TURNING, LOCKING AND BRAKING (TLB) SYSTEM

- Twiflex provides a superior solution with a continuous turning design for the same price as a comparable indexing solution
 - Infinite positioning
 - Fixed speed in both directions (variable as an option)
 - Balanced load profile
 - Quicker & safer stopping
- Fully modular solution providing the customer an option to select each function T,L,B, individually or combined TL, TB or LB in addition to the complete TLB system
- Flexible designs to meet customer requirements with full design and build completely in-house
 - Many configurations available based on five standard brake disc sizes with turning torques up to 334,850 lb-ft and turning speeds up to 2.6 rpm depending on configuration.
 - Wide range of well proven locking devices and brakes with torques up to 635,500 lb-ft based on the standard range. Custom disc sizes available.
- Local and Remote operation to suit customer preference
- Manual Turning and Locking available for power failure condition

A Superior Solution From A Single Source

- Complete System Provider: brakes, actuation methods, controls, hydraulics, locking devices, etc.
- Strong Design & Technical Competence
- Full Design & Build In-House
- Custom Modular Solutions
- Renowned Testing Facilities
- Balanced Braking
- Brand Longevity
- Superior Continuous Turning Design
- Extensive Marine Application Expertise
- Marine Service Capabilities

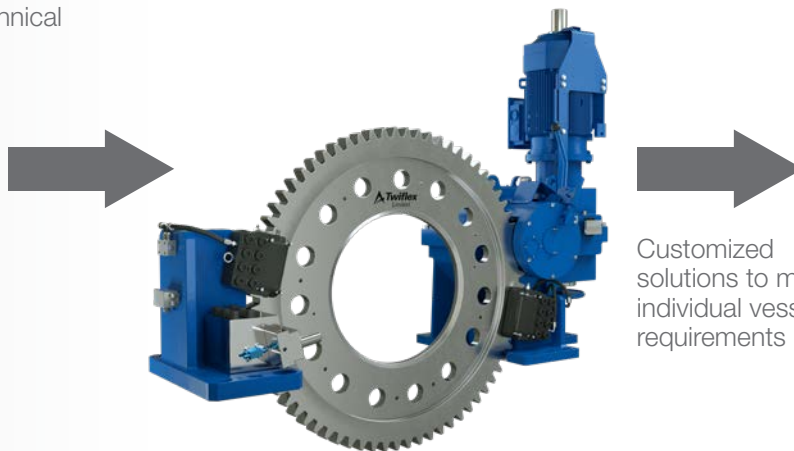

Customized solutions to meet individual vessel requirements

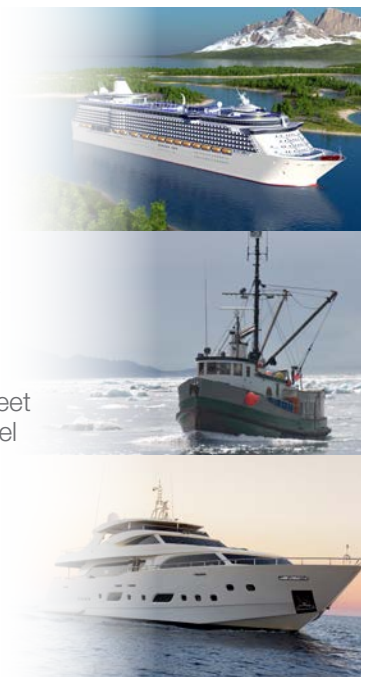

TWIFLEX TLB SYSTEM FOR MARINE PROPULSION

The Twiflex TLB system is fully modular and can be supplied as a complete TLB package or variations as shown above: Turning only 'T', Locking only 'L', Braking only 'B' Turning and Braking 'TB', Locking and Braking 'LB' or Turning and Locking 'TL'.

All systems are fully monitored and are designed to provide an interface with the customers bridge control.

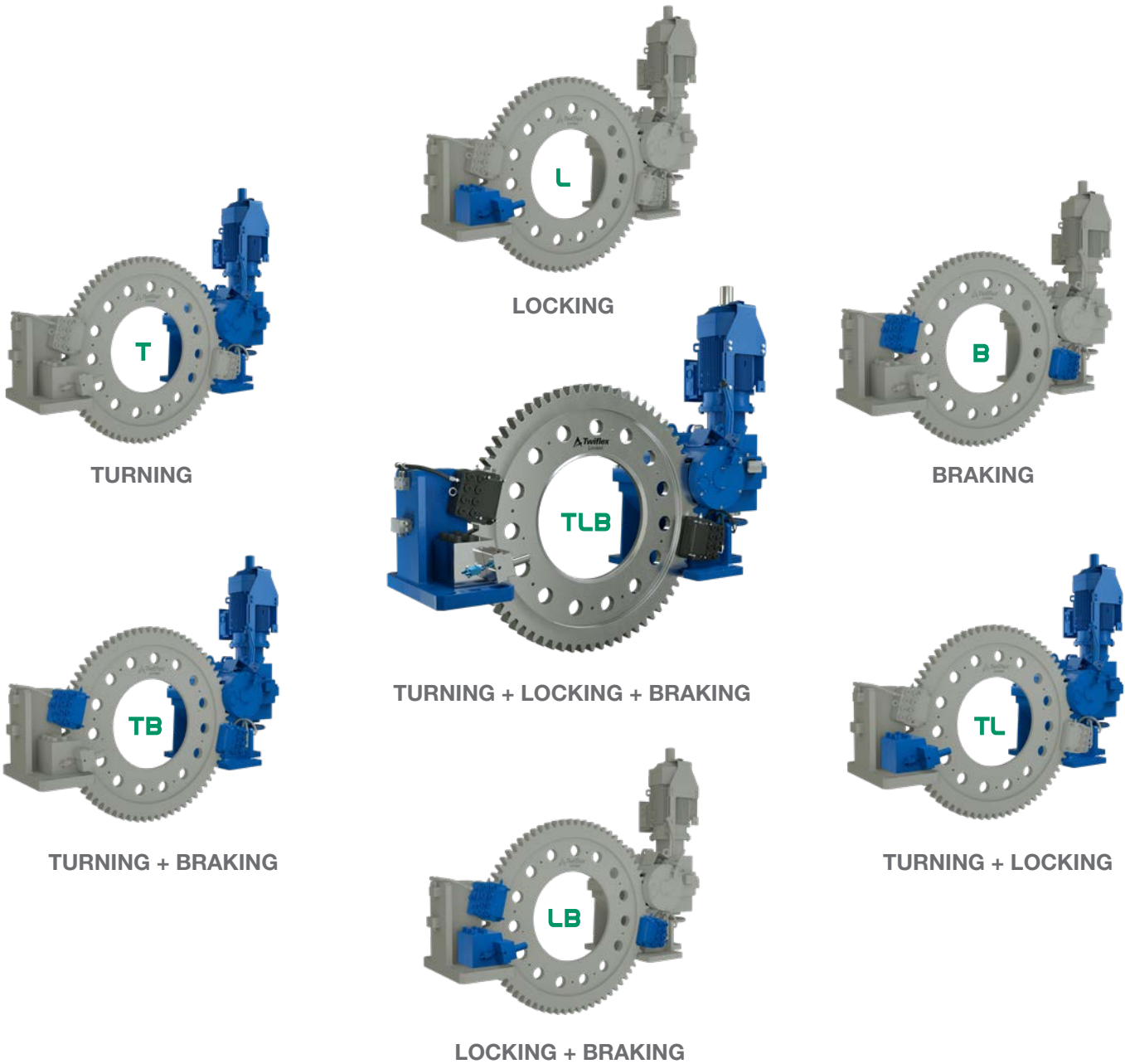

ALTRA HAS MANY YEARS OF EXPERIENCE DESIGNING AND SUPPLYING HYDRAULIC, ELECTRO-PNEUMATIC, AND AIR-OVER-OIL CONTROLS FOR BRAKES AND CLUTCHES USED IN THE MARINE INDUSTRY.

The TLB system includes a fully monitored control system with a remote panel offering local control. While in normal operation, the system is operated and monitored by the ship's bridge control allowing only the brakes to be applied, for example, in an emergency condition or for fast maneuvering to provide rapid directional change for twin screw vessels. In local control, the turning gear and locking device can be operated along with the brakes allowing full TLB control.

For installations where braking and/or locking is required, power units can be supplied in various options (air, hydraulic, air-over-oil) along with an operating panel to provide basic control and monitoring to suit.

Altra also offers a full range of direct pneumatic applied spring release scissor and dual spring brakes along with air-over-oil systems to meet both ship supply options.



TYPICAL TWIFLEX TLB POWER UNIT AND CONTROL

WHY DO CUSTOMERS SELECT **TWIFLEX** TLB SYSTEMS?



Problem: A leading global marine propulsion system OEM required a unique drive shaft turning, locking and braking solution for use on a next-generation ice-breaking vessel. Controlled locally or from the bridge, the equipment fitted to each of the three propeller drives rotates and holds the propulsion shaft during maintenance. It also stops and locks the drive shaft to prevent the propeller from rotating when the vessel is moored in a flow stream.

Solution: The custom Twiflex TLB-180 produces a continuous turning torque of 103,260 lb-ft at 0.6 rpm in both directions with a dynamic braking capacity and static locking torque rated up to 132,760 lb-ft. The system features a 4.9 ft (1.5 m) diameter split disc with a gear tooth profile which easily mounts onto a flange without the need to disassemble the main propulsion shaft.

TWIFLEX TLB SPECIFICATIONS

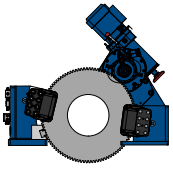
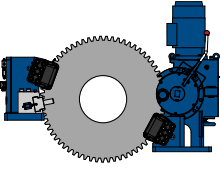
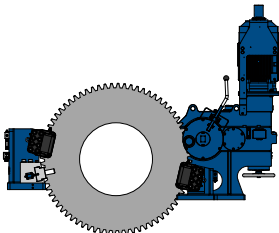
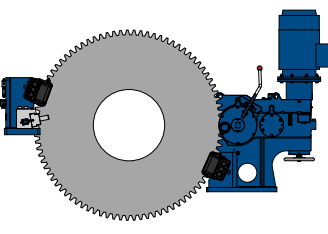
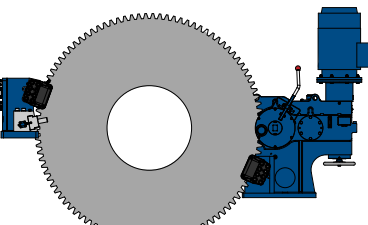
	Disc Dia. (inches)	Turning Torque (lb-ft)		Turning Speed/ (rpm)		Locking Torque (lb-ft)	Braking Torque (lb-ft)	
		Min	Max	Min	Max	Nom	Min	Max
	32	10,550	116,560	0.38	2.64	23,600	11,780	23,570
	48	15,840	174,830	0.25	1.76	53,100	26,580	53,160
	60	19,800	218,540	0.20	1.41	140,140	69,860	139,730
	80	26,400	291,380	0.15	1.06	157,840	78,770	157,530
	92	30,360	335,100	0.13	0.92	635,780	317,770	635,530

- Braking Torques are calculated using direct applied, spring release hydraulic brakes. Direct applied, spring release pneumatic brakes are also available
- Max operating pressure used in the above calculations is 2,176 psi
- Coefficient of Friction (μ) has been taken as 0.4
- Max. Braking Torque assumes 2 off brakes (same model and rating) are used on a single brake disc
- Configurations shown are complete TLB systems with continuous turning (-C). Indexing (-I) or manual systems (-M) are available upon request
- All Turning Gear options include the facility for manual turning in addition to normal operation
- The geared brake disc can be supplied as a solid or as a split design