

Wood's Sure-Grip® QD Bushings

A1

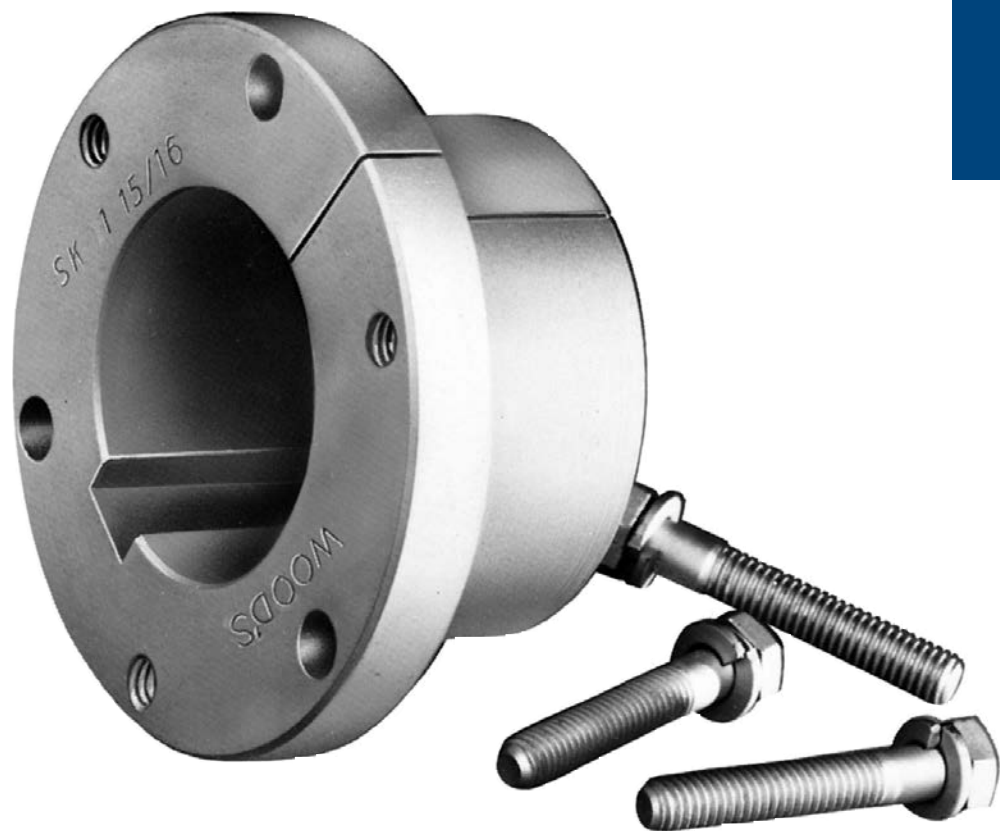

- **Provide a True Clamp Fit**
- **Are Easy to Install and Remove**
- **Permit Four-Way Mounting**

Sure-Grip® Bushings

Features

Sure-Grip® “Quick Detachable” bushings are easy to install and remove. They are split through flange and taper to provide a true clamp on the shaft that is the equivalent of a shrink fit. All sizes except JA and QT have a setscrew over the key to help

maintain the bushing’s position on the shaft until the cap screws are securely tightened. Sure-Grip bushings have a very gradual taper (3/4-inch taper per ft. on the diameter) which is about half the inclined angle of many other bushings. The result is the Sure-Grip securely clamps the shaft, with twice the force of those competitive bushings, to provide extreme holding power.

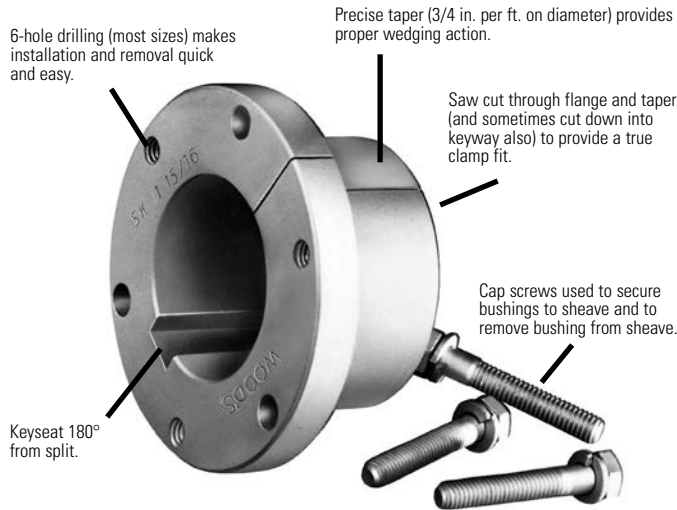

Versatile Sure-Grip bushings permit the mounting of the same mating part on shafts of different diameters, and the mounting of different sheaves on the same shaft using the same bushing. Their interchangeability extends through sheaves, pulleys, timing pulleys, sprockets, flexible and rigid couplings, made-to-order items by Wood’s, and to product lines of several other mechanical power transmission manufacturers.

Sure-Grip bushings are manufactured with the drilled and tapped holes located at a precise distance from the keyseat; thus, a wide mating part having a bushing in each end can be mounted on a common shaft with the two keyways in line. This feature not only facilitates installation but also permits both bushings to carry an equal share of the load.

STANDARD MOUNTING

REVERSE MOUNTING

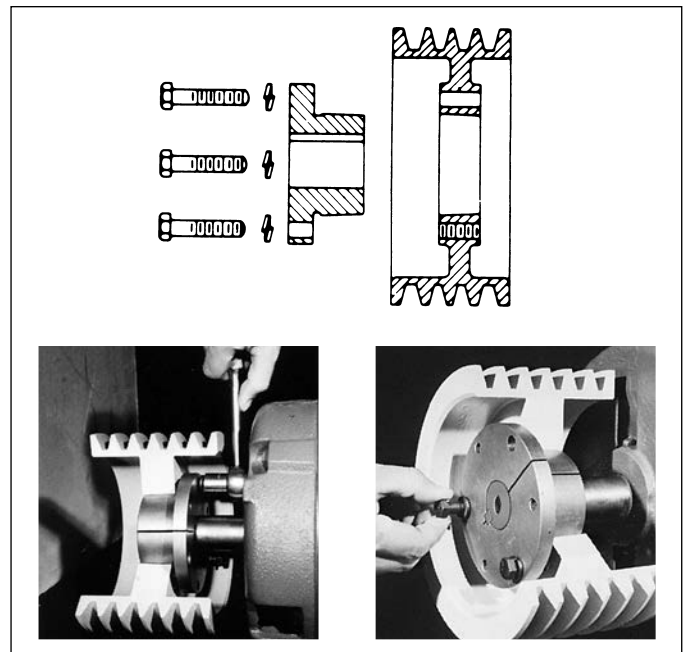
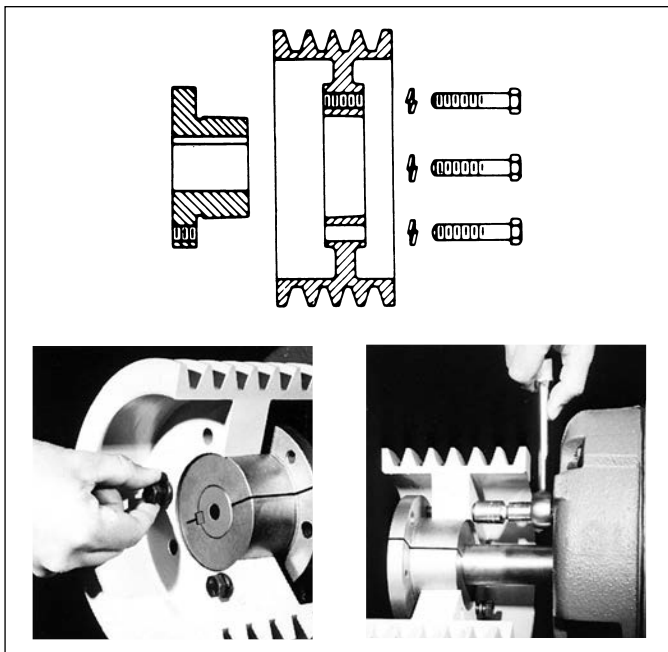

- 1.** Cap screws from outside through drilled holes in the mating part and into threaded holes in the bushing flange located on the inside of the assembly. Or the complete assembly reversed on the shaft and;
- 2.** Cap screws from inside through drilled holes in the mating part and into threaded holes in the bushing flange located on the outside of the assembly.
- 3.** Cap screws from inside through drilled holes in the bushing flange located on the inside of the assembly and into threaded holes in the mating part.
- 4.** Cap screws from outside through drilled holes in the bushing flange located on the outside of the assembly and into threaded holes in the mating part.

Dimensions

Sure-Grip bushings are designed to transmit the rated torque capacity listed in the table below when the cap screws are tightened as indicated. The bushings are stocked in all popular bore sizes, including metric bores, within the bore range for a particular bushing.

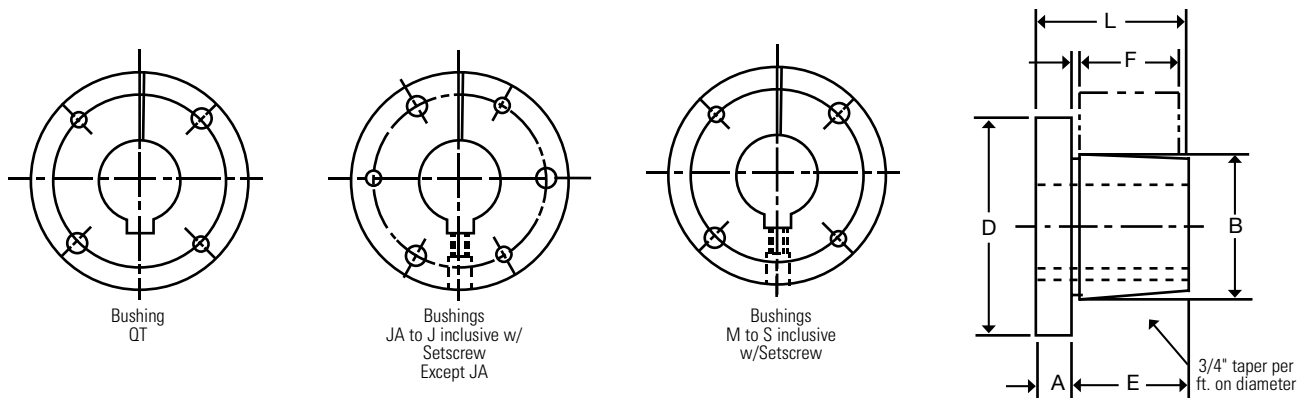

SURE-GRIP BUSHING TORQUE RATINGS AND DIMENSIONS

Bush.	Torque Capacity (In.-Lbs.)	(Note 1) Max. Bore	(Note 2) Max. Bore	DIMENSIONS IN INCHES						Bolt Circle	Cap Screws Required
				A	B	D	E	F*	L		
QT	1,750	1-1/2	30	1/4	1.625	2-1/2	1	7/8	1-1/4	2	2-1/4 x 1
JA	1,750	1-1/4	23	5/16	1.375	2	11/16	9/16	1	1-21/32	3 - #10 x 1
SH	3,500	1-5/8	36	3/8	1.871	2-11/16	7/8	13/16	1-1/4	2-1/4	3-1/4 x 1-3/8
SDS	5,000	1-15/16	42	7/16	2.1875	3-3/16	7/8	3/4	1-5/16	2-11/16	3-1/4 x 1-3/8
SD	5,000	1-15/16	42	7/16	2.1875	3-3/16	1-3/8	1-1/4	1-13/16	2-11/16	3-1/4 x 1-7/8
SK	7,000	2-1/2	56	1/2	2.8125	3-7/8	1-3/8	1-1/4	1-7/8	3-5/16	3-5/16 x 2
SF	11,000	2-15/16	63	1/2	3.125	4-5/8	1-1/2	1-1/4	2	3-7/8	3-3/8 x 2
E	20,000	3-1/2	78	3/4	3.834	6	1-7/8	1-5/8	2-5/8	5	3-1/2 x 2-3/4
F	40,000	3-15/16	90	13/16	4.4375	6-5/8	2-13/16	2-1/2	3-5/8	5-5/8	3-9/16 x 3-5/8
J	55,000	4-1/2	105	1	5.1484	7-1/4	3-1/2	3-3/16	4-1/2	6-1/4	3-5/8 x 4-1/2
M	125,000	5-1/2	130	1-1/4	6.500	9-1/8	5-1/2	5-3/16	6-3/4	7-7/8	4-3/4 x 6-3/4
N	150,000	6	140	1-1/2	7.000	10	6-5/8	6-1/4	8-1/8	8-1/2	4-7/8 x 8
P	250,000	7	160	1-3/4	8.250	11-3/4	7-5/8	7-1/4	9-3/8	10	4 - 1 x 9-1/2
W	375,000	8-1/2	200	2	10.437	15	9-3/8	9	11-3/8	12-3/4	4 - 1-1/8 x 11-1/2
S	625,000	10	240	3-1/4	12.125	17-3/4	12-1/2	12	15-3/4	15	5 - 1-1/4 x 15-1/2

* Mating hub length.

1. MAX INCH BORE WITH KEYSEAT.

2. MAX MM BORE WITH STANDARD KEYSEAT.

See pages A1-4 to A1-8 for Bore and Keyseat information and weights.

SURE-GRIP® BUSHINGS

Bore and Key Seat Dimensions

Sure-Grip Bushings are available from stock with all the bores and keyseats listed below. In some cases, as the bore increases in diameter, a shallow keyseat is provided—due to insufficient metal thickness. When this happens, Wood's furnishes the correct rectangular key to suit at no charge. This does not affect the bushing's ability to transmit the load. The rectangular key, or flat key as some call it, fits into the standard keyway in the shaft.

DIMENSIONS (In Inches)

Product No.	Bore	Key Seat	Wt. (*)
QT BUSHINGS			
QTMPB	7/16	No KS	.6
QT12	1/2	1/8 x 1/16	.6
QT9/16	9/16	1/8 x 1/16	.6
QT58	5/8	3/16 x 3/32	.6
QT11/16	11/16	3/16 x 3/32	.6
QT34	3/4	3/16 x 3/32	.6
QT13/16	13/16	3/16 x 3/32	.6
QT78	7/8	3/16 x 3/32	.6
QT15/16	15/16	1/4 x 1/8	.6
QT1	1	1/4 x 1/8	.6
QT1116	1-1/16	1/4 x 1/8	.6
QT118	1-1/8	1/4 x 1/8	.6
QT1316	1-3/16	1/4 x 1/8	.6
QT114	1-1/4	1/4 x 1/8	.6
QT1516	1-5/16	5/16 x 1/16	.6
QT138	1-3/8	5/16 x 1/16	.6
QT1716	1-7/16	3/8 x 1/16	.6
QT112	1-1/2	3/8 x 1/16	.6
JA BUSHINGS			
JAMPB	1/2	No KS	.8
JA12	1/2	1/8 x 1/16	.8
JA9/16	9/16	1/8 x 1/16	.8
JA58	5/8	3/16 x 3/32	.8
JA11/16	11/16	3/16 x 3/32	.8
JA34	3/4	3/16 x 3/32	.8
JA13/16	13/16	3/16 x 3/32	.8
JA78	7/8	3/16 x 3/32	.8
JA15/16	15/16	1/4 x 1/8	.8
JA1	1	1/4 x 1/8	.8
JA1116	1-1/16	1/4 x 1/16	.8
JA118	1-1/8	1/4 x 1/16	.8
JA1316	1-3/16	1/4 x 1/16	.8
JA114	1-1/4	1/4 x 1/32	.8
SH BUSHINGS			
SHMPB	7/16	No KS	1.1
SH12	1/2	1/8 x 1/16	1.1
SH9/16	9/16	1/8 x 1/16	1.1
SH58	5/8	3/16 x 3/32	1.1
SH11/16	11/16	3/16 x 3/32	1.0
SH34	3/4	3/16 x 3/32	1.0
SH13/16	13/16	3/16 x 3/32	1.0
SH78	7/8	3/16 x 3/32	1.0
SH15/16	15/16	1/4 x 1/8	1.0
SH1	1	1/4 x 1/8	.9

Product No.	Bore	Key Seat	Wt. (*)
SH BUSHINGS (continued)			
SH1116	1-1/16	1/4 x 1/8	.9
SH118	1-1/8	1/4 x 1/8	.9
SH1316	1-3/16	1/4 x 1/8	.8
SH114	1-1/4	1/4 x 1/8	.8
SH1516	1-5/16	5/16 x 5/32	.7
SH138	1-3/8	5/16 x 5/32	.7
SH1716	1-7/16	3/8 x 1/16	.7
SH112	1-1/2	3/8 x 1/16	.6
SH1916	1-9/16	3/8 x 1/16	.6
SH158	1-5/8	3/8 x 1/16	.5
SH11116	1-11/16	No KS	.5
SDS BUSHINGS			
SDSMPB	7/16	No KS	1.7
SDS12	1/2	1/8 x 1/16	1.7
SDS9/16	9/16	1/8 x 1/16	1.7
SDS58	5/8	3/16 x 3/32	1.6
SDS11/16	11/16	3/16 x 3/32	1.6
SDS34	3/4	3/16 x 3/32	1.6
SDS13/16	13/16	3/16 x 3/32	1.6
SDS78	7/8	3/16 x 3/32	1.5
SDS15/16	15/16	1/4 x 1/8	1.5
SDS1	1	1/4 x 1/8	1.5
SDS1116	1-1/16	1/4 x 1/8	1.4
SDS118	1-1/8	1/4 x 1/8	1.4
SDS1316	1-3/16	1/4 x 1/8	1.4
SDS114	1-1/4	1/4 x 1/8	1.3
SDS1516	1-5/16	5/16 x 5/32	1.3
SDS138	1-3/8	5/16 x 5/32	1.2
SDS13838KS	1-3/8	3/8 x 3/16	1.2
SDS1716	1-7/16	3/8 x 3/16	1.2
SDS112	1-1/2	3/8 x 3/16	1.1
SDS1916	1-9/16	3/8 x 3/16	1.1
SDS158	1-5/8	3/8 x 3/16	1.0
SDS11116	1-11/16	3/8 x 3/16	1.0
SDS134	1-3/4	3/8 x 1/8	1.0
SDS11316	1-13/16	1/2 x 1/8	.9
SDS178	1-7/8	1/2 x 1/16	.9
SDS11516	1-15/16	1/2 x 1/16	.8
SDS2	2	No KS	.7
SD BUSHINGS			
SDMPB	7/16	No KS	2.1
SD12	1/2	1/8 x 1/16	2.1
SD9/16	9/16	1/8 x 1/16	2.1
SD58	5/8	3/16 x 3/32	2.1
SD11/16	11/16	3/16 x 3/32	2.0

Product No.	Bore	Key Seat	Wt. (*)
SD BUSHINGS (continued)			
SD34	3/4	3/16 x 3/32	2.0
SD13/16	13/16	3/16 x 3/32	2.0
SD78	7/8	3/16 x 3/32	1.9
SD15/16	15/16	1/4 x 1/8	1.9
SD1	1	1/4 x 1/8	1.8
SD1116	1-1/16	1/4 x 1/8	1.8
SD118	1-1/8	1/4 x 1/8	1.7
SD1316	1-3/16	1/4 x 1/8	1.7
SD114	1-1/4	1/4 x 1/8	1.6
SD1516	1-5/16	5/16 x 5/32	1.6
SD138	1-3/8	5/16 x 5/32	1.5
SD13838KS	1-3/8	3/8 x 3/16	1.5
SD1716	1-7/16	3/8 x 3/16	1.4
SD112	1-1/2	3/8 x 3/16	1.4
SD1916	1-9/16	3/8 x 3/16	1.3
SD158	1-5/8	3/8 x 3/16	1.2
SD11116	1-11/16	3/8 x 3/16	1.2
SD134	1-3/4	3/8 x 1/8	1.1
SD11316	1-13/16	1/2 x 1/8	1.1
SD178	1-7/8	1/2 x 1/16	1.0
SD11516	1-15/16	1/2 x 1/16	.9
SD2	2	No KS	.8
SK BUSHINGS			
SKMPB	7/16	No KS	3.6
SK12	1/2	1/8 x 1/16	3.6
SK9/16	9/16	1/8 x 1/16	3.6
SK58	5/8	3/16 x 3/32	3.6
SK11/16	11/16	3/16 x 3/32	3.5
SK34	3/4	3/16 x 3/32	3.5
SK13/16	13/16	3/16 x 3/32	3.5
SK78	7/8	3/16 x 3/32	3.4
SK15/16	15/16	1/4 x 1/8	3.4
SK1	1	1/4 x 1/8	3.3
SK1116	1-1/16	1/4 x 1/8	3.3
SK118	1-1/8	1/4 x 1/8	3.2
SK1316	1-3/16	1/4 x 1/8	3.2
SK114	1-1/4	1/4 x 1/8	3.1
SK1516	1-5/16	5/16 x 5/32	3.1
SK151638KS	1-5/16	3/8 x 3/16	3.1
SK138	1-3/8	5/16 x 5/32	3.0
SK13838KS	1-3/8	3/8 x 3/16	3.0
SK1716	1-7/16	3/8 x 3/16	2.9
SK112	1-1/2	3/8 x 3/16	2.9
SK1916	1-9/16	3/8 x 3/16	2.8
SK158	1-5/8	3/8 x 3/16	2.7
SK11116	1-11/16	3/8 x 3/16	2.6
SK134	1-3/4	3/8 x 3/16	2.5
SK13412KS	1-3/4	1/2 x 1/4	2.5

* Approximate weight in lbs.

MPB Bushings are unsplit.

(Continued—next page)

Bore and Key Seat Dimensions

DIMENSIONS (In Inches)

Product No.	Bore	Key Seat	Wt. (*)
SK BUSHINGS (continued)			
SK11316	1-13/16	1/2 x 1/4	2.4
SK178	1-7/8	1/2 x 1/4	2.4
SK11516	1-15/16	1/2 x 1/4	2.3
SK2	2	1/2 x 1/4	2.2
SK2116	2-1/16	1/2 x 1/4	2.1
SK218	2-1/8	1/2 x 1/4	2.0
SK2316	2-3/16	1/2 x 1/8	2.0
SK214	2-1/4	1/2 x 1/8	1.9
SK21458KS	2-1/4	5/8 x 1/8	1.9
SK2516	2-5/16	5/8 x 1/16	1.8
SK238	2-3/8	5/8 x 1/16	1.7
SK2716	2-7/16	5/8 x 1/16	1.6
SK212	2-1/2	5/8 x 1/16	1.5
SK2916	2-9/16	No KS	1.3
SK258	2-5/8	No KS	1.1
SF BUSHINGS			
SFMPB	1/2	No KS	5.1
SF12	1/2	1/8 x 1/16	5.1
SF58	5/8	3/16 x 3/32	5.0
SF34	3/4	3/16 x 3/32	5.0
SF78	7/8	3/16 x 3/32	4.9
SF15/16	15/16	1/4 x 1/8	4.8
SF1	1	1/4 x 1/8	4.8
SF1116	1-1/16	1/4 x 1/8	4.7
SF118	1-1/8	1/4 x 1/8	4.7
SF1316	1-3/16	1/4 x 1/8	4.6
SF114	1-1/4	1/4 x 1/8	4.5
SF1516	1-5/16	5/16 x 5/32	4.5
SF138	1-3/8	5/16 x 5/32	4.4
SF13838KS	1-3/8	3/8 x 3/16	4.4
SF1716	1-7/16	3/8 x 3/16	4.3
SF112	1-1/2	3/8 x 3/16	4.2
SF1916	1-9/16	3/8 x 3/16	4.2
SF158	1-5/8	3/8 x 3/16	4.1
SF11116	1-11/16	3/8 x 3/16	4.0
SF134	1-3/4	3/8 x 3/16	3.9
SF11316	1-13/16	1/2 x 1/4	3.8
SF178	1-7/8	1/2 x 1/4	3.7
SF11516	1-15/16	1/2 x 1/4	3.6
SF2	2	1/2 x 1/4	3.5
SF2116	2-1/16	1/2 x 1/4	3.4
SF218	2-1/8	1/2 x 1/4	3.3
SF2316	2-3/16	1/2 x 1/4	3.2
SF214	2-1/4	1/2 x 1/4	3.1
SF21458KS	2-1/4	5/8 x 5/16	3.1
SF2516	2-5/16	5/8 x 3/16	3.1
SF238	2-3/8	5/8 x 3/16	3.0
SF2716	2-7/16	5/8 x 3/16	2.9
SF212	2-1/2	5/8 x 3/16	2.8
SF2916	2-9/16	5/8 x 1/16	2.6
SF258	2-5/8	5/8 x 1/16	2.5
SF21116	2-11/16	5/8 x 1/16	2.4
SF234	2-3/4	5/8 x 1/16	2.2
SF278	2-7/8	3/4 x 1/16	1.8
SF21516	2-15/16	3/4 x 1/32	1.7

Product No.	Bore	Key Seat	Wt. (*)
E BUSHINGS			
EMPB	7/8	No KS	10.8
E78	7/8	3/16 x 3/32	10.8
E15/16	15/16	1/4 x 1/8	10.8
E1	1	1/4 x 1/8	10.7
E118	1-1/8	1/4 x 1/8	10.6
E1316	1-3/16	1/4 x 1/8	10.5
E114	1-1/4	1/4 x 1/8	10.4
E1516	1-5/16	5/16 x 5/32	10.3
E138	1-3/8	5/16 x 5/32	10.2
E13838KS	1-3/8	3/8 x 3/16	10.2
E1716	1-7/16	3/8 x 3/16	10.1
E112	1-1/2	3/8 x 3/16	10.0
E1916	1-9/16	3/8 x 3/16	9.9
E158	1-5/8	3/8 x 3/16	9.8
E11116	1-11/16	3/8 x 3/16	9.7
E134	1-3/4	3/8 x 3/16	9.6
E11316	1-13/16	1/2 x 1/4	9.4
E178	1-7/8	1/2 x 1/4	9.3
E11516	1-15/16	1/2 x 1/4	9.2
E2	2	1/2 x 1/4	9.0
E2116	2-1/16	1/2 x 1/4	8.9
E218	2-1/8	1/2 x 1/4	8.8
E2316	2-3/16	1/2 x 1/4	8.6
E214	2-1/4	1/2 x 1/4	8.5
E21458KS	2-1/4	5/8 x 5/16	8.5
E2516	2-5/16	5/8 x 5/16	8.3
E238	2-3/8	5/8 x 5/16	8.1
E2716	2-7/16	5/8 x 5/16	8.0
E212	2-1/2	5/8 x 5/16	7.8
E2916	2-9/16	5/8 x 5/16	7.6
E258	2-5/8	5/8 x 5/16	7.5
E21116	2-11/16	5/8 x 5/16	7.3
E234	2-3/4	5/8 x 5/16	7.1
E21316	2-13/16	3/4 x 3/8	7.2
E278	2-7/8	3/4 x 3/8	7.1
E21516	2-15/16	3/4 x 1/8	6.9
E3	3	3/4 x 1/8	6.7
E318	3-1/8	3/4 x 1/8	6.3
E3316	3-3/16	3/4 x 1/8	6.0
E314	3-1/4	3/4 x 1/8	5.8
E3516	3-5/16	7/8 x 1/16	5.7
E338	3-3/8	7/8 x 1/16	5.5
E3716	3-7/16	7/8 x 1/16	5.2
E312	3-1/2	7/8 x 1/16	4.7
F BUSHINGS			
FMPB	1	No KS	17.9
F1	1	1/4 x 1/8	17.9
F118	1-1/8	1/4 x 1/8	17.7
F1316	1-3/16	1/4 x 1/8	17.6
F114	1-1/4	1/4 x 1/8	17.5
F138	1-3/8	5/16 x 5/32	17.2
F1716	1-7/16	3/8 x 3/16	17.1
F112	1-1/2	3/8 x 3/16	16.9
F1916	1-9/16	3/8 x 3/16	16.8
F158	1-5/8	3/8 x 3/16	16.7

Product No.	Bore	Key Seat	Wt. (*)
F BUSHING (continued)			
F134	1-3/4	3/8 x 3/16	16.3
F178	1-7/8	1/2 x 1/4	16.0
F11516	1-15/16	1/2 x 1/4	15.8
F2	2	1/2 x 1/4	15.6
F2116	2-1/16	1/2 x 1/4	15.4
F218	2-1/8	1/2 x 1/4	15.2
F2316	2-3/16	1/2 x 1/4	15.0
F214	2-1/4	1/2 x 1/4	14.8
F21458KS	2-1/4	5/8 x 5/16	14.8
F2516	2-5/16	5/8 x 5/16	14.5
F238	2-3/8	5/8 x 5/16	14.3
F2716	2-7/16	5/8 x 5/16	14.1
F212	2-1/2	5/8 x 5/16	13.9
F2916	2-9/16	5/8 x 5/16	13.7
F258	2-5/8	5/8 x 5/16	13.4
F21116	2-11/16	5/8 x 5/16	13.2
F234	2-3/4	5/8 x 5/16	12.9
F21316	2-13/16	3/4 x 3/8	12.6
F278	2-7/8	3/4 x 3/8	12.3
F21516	2-15/16	3/4 x 3/8	12.1
F3	3	3/4 x 3/8	11.8
F318	3-1/8	3/4 x 3/8	11.2
F3316	3-3/16	3/4 x 3/8	10.9
F314	3-1/4	3/4 x 3/8	10.6
F3516	3-5/16	7/8 x 3/16	11.0
F338	3-3/8	7/8 x 3/16	10.6
F3716	3-7/16	7/8 x 3/16	10.3
F312	3-1/2	7/8 x 3/16	10.0
F358	3-5/8	7/8 x 3/16	9.4
F31116	3-11/16	7/8 x 3/16	9.0
F334	3-3/4	7/8 x 3/16	8.7
F378	3-7/8	1 x 1/8	8.1
F31516	3-15/16	1 x 1/8	7.7
F4	4	No KS	6.9
J BUSHINGS			
JMPB	1-7/16	No KS	28.1
J1716	1-7/16	3/8 x 3/16	28.1
J112	1-1/2	3/8 x 3/16	28.0
J1916	1-9/16	3/8 x 3/16	27.8
J1116	1-11/16	3/8 x 3/16	27.4
J134	1-3/4	3/8 x 3/16	27.2
J178	1-7/8	1/2 x 1/4	26.7
J11516	1-15/16	1/2 x 1/4	26.5
J2	2	1/2 x 1/4	26.3
J218	2-1/8	1/2 x 1/4	25.8
J2316	2-3/16	1/2 x 1/4	25.6
J214	2-1/4	1/2 x 1/4	25.3
J2516	2-5/16	5/8 x 5/16	25.0
J238	2-3/8	5/8 x 5/16	24.7
J2716	2-7/16	5/8 x 5/16	24.5
J212	2-1/2	5/8 x 5/16	24.2
J258	2-5/8	5/8 x 5/16	23.6
J21116	2-11/16	5/8 x 5/16	23.3
J234	2-3/4	5/8 x 5/16	23.0
J278	2-7/8	3/4 x 3/8	22.2

Approximate weight in lbs.

MPB Bushings are unsplit.

(Continued—next page)

Bore And Key Seat Dimensions

DIMENSIONS (In Inches)

Product No.	Bore	Key Seat	Wt. (*)
J BUSHINGS (continued)			
J21516	2-15/16	3/4 x 3/8	21.9
J3	3	3/4 x 3/8	21.6
J318	3-1/8	3/4 x 3/8	20.9
J3316	3-3/16	3/4 x 3/8	20.5
J314	3-1/4	3/4 x 3/8	20.1
J3516	3-5/16	7/8 x 7/16	19.6
J338	3-3/8	7/8 x 7/16	19.3
J3716	3-7/16	7/8 x 7/16	18.9
J312	3-1/2	7/8 x 7/16	18.5
J358	3-5/8	7/8 x 7/16	17.7
J31116	3-11/16	7/8 x 7/16	17.2
J334	3-3/4	7/8 x 7/16	16.8
J31316	3-13/16	1 x 1/2	17.4
J378	3-7/8	1 x 3/8	17.0
J31516	3-15/16	1 x 3/8	16.5
J4	4	1 x 1/8	16.1
J418	4-1/8	1 x 1/8	15.2
J4316	4-3/16	1 x 1/8	14.7
J414	4-1/4	1 x 1/8	14.2
J438	4-3/8	1 x 1/8	13.2
J4716	4-7/16	1 x 1/8	12.7
J412	4-1/2	1 x 1/8	12.2
M BUSHINGS			
M11516	1-15/16	1/2 x 1/4	63.7
M2	2	1/2 x 1/4	63.3
M2316	2-3/16	1/2 x 1/4	62.3
M214	2-1/4	1/2 x 1/4	61.9
M238	2-3/8	5/8 x 5/16	61.0
M2716	2-7/16	5/8 x 5/16	60.6
M212	2-1/2	5/8 x 5/16	60.1
M258	2-5/8	5/8 x 5/16	59.3
M21116	2-11/16	5/8 x 5/16	58.8
M234	2-3/4	5/8 x 5/16	58.3
M278	2-7/8	3/4 x 3/8	57.2
M21516	2-15/16	3/4 x 3/8	56.7
M3	3	3/4 x 3/8	56.2
M318	3-1/8	3/4 x 3/8	55.2
M3316	3-3/16	3/4 x 3/8	54.6
M314	3-1/4	3/4 x 3/8	54.1
M338	3-3/8	7/8 x 7/16	52.8
M3716	3-7/16	7/8 x 7/16	52.2
M312	3-1/2	7/8 x 7/16	51.6
M358	3-5/8	7/8 x 7/16	50.4
M31116	3-11/16	7/8 x 7/16	49.7
M334	3-3/4	7/8 x 7/16	49.1
M378	3-7/8	1 x 1/2	47.6
M31516	3-15/16	1 x 1/2	46.9
M4	4	1 x 1/2	46.2
M418	4-1/8	1 x 1/2	44.8
M4316	4-3/16	1 x 1/2	44.1
M414	4-1/4	1 x 1/2	43.4
M438	4-3/8	1 x 1/2	41.9
M4716	4-7/16	1 x 1/2	41.2

Product No.	Bore	Key Seat	Wt. (*)
M BUSHINGS (continued)			
M412	4-1/2	1 x 1/2	40.4
M41116	4-11/16	1-1/4 x 5/8	37.5
M434	4-3/4	1-1/4 x 5/8	36.7
M478	4-7/8	1-1/4 x 1/4	37.8
M41516	4-15/16	1-1/4 x 1/4	37.0
M5	5	1-1/4 x 1/4	36.1
M5316	5-3/16	1-1/4 x 1/4	33.5
M514	5-1/4	1-1/4 x 1/4	32.6
M5716	5-7/16	1-1/4 x 1/4	29.9
M512	5-1/2	1-1/4 x 1/4	28.9
N BUSHINGS			
N21516	2-15/16	3/4 x 3/8	84.1
N3	3	3/4 x 3/8	83.5
N338	3-3/8	7/8 x 7/16	79.3
N3716	3-7/16	7/8 x 7/16	78.6
N312	3-1/2	7/8 x 7/16	77.9
N358	3-5/8	7/8 x 7/16	76.4
N334	3-3/4	7/8 x 7/16	74.9
N378	3-7/8	1 x 1/2	73.1
N31516	3-15/16	1 x 1/2	72.3
N4	4	1 x 1/2	71.5
N4316	4-3/16	1 x 1/2	68.9
N414	4-1/4	1 x 1/2	68.1
N438	4-3/8	1 x 1/2	66.3
N4716	4-7/16	1 x 1/2	65.4
N412	4-1/2	1 x 1/2	64.5
N458	4-5/8	1-1/4 x 5/8	62.0
N434	4-3/4	1-1/4 x 5/8	60.0
N478	4-7/8	1-1/4 x 5/8	58.1
N41516	4-15/16	1-1/4 x 5/8	57.0
N5	5	1-1/4 x 5/8	56.0
N5316	5-3/16	1-1/4 x 1/4	56.1
N5716	5-7/16	1-1/4 x 1/4	51.7
N512	5-1/2	1-1/4 x 1/4	50.6
N578	5-7/8	1-1/2 x 1/4	44.3
N51516	5-15/16	1-1/2 x 1/8	43.9
P BUSHINGS			
P21516	2-15/16	3/4 x 3/8	141.2
P314	3-1/4	3/4 x 3/8	137.6
P3716	3-7/16	7/8 x 7/16	134.9
P312	3-1/2	7/8 x 7/16	134.1
P358	3-5/8	7/8 x 7/16	132.4
P334	3-3/4	7/8 x 7/16	130.6
P378	3-7/8	1 x 1/2	128.5
P31516	3-15/16	1 x 1/2	127.6
P4	4	1 x 1/2	126.7
P414	4-1/4	1 x 1/2	122.7
P438	4-3/8	1 x 1/2	120.7
P4716	4-7/16	1 x 1/2	119.6
P412	4-1/2	1 x 1/2	118.6
P458	4-5/8	1-1/4 x 5/8	115.7
P41116	4-11/16	1-1/4 x 5/8	114.6

Product No.	Bore	Key Seat	Wt. (*)
P BUSHINGS (continued)			
P434	4-3/4	1-1/4 x 5/8	113.5
P478	4-7/8	1-1/4 x 5/8	111.2
P41516	4-15/16	1-1/4 x 5/8	110.0
P5	5	1-1/4 x 5/8	108.8
P5316	5-3/16	1-1/4 x 5/8	105.2
P514	5-1/4	1-1/4 x 5/8	103.9
P5516	5-5/16	1-1/4 x 5/8	102.7
P538	5-3/8	1-1/4 x 5/8	101.4
P5716	5-7/16	1-1/4 x 5/8	100.1
P512	5-1/2	1-1/4 x 5/8	98.8
P534	5-3/4	1-1/2 x 3/4	98.1
P578	5-7/8	1-1/2 x 3/4	95.3
P51516	5-15/16	1-1/2 x 3/4	93.9
P6	6	1-1/2 x 1/4	92.5
P6116	6-1/16	1-1/2 x 1/4	91.0
P614	6-1/4	1-1/2 x 1/4	86.6
P6716	6-7/16	1-1/2 x 1/4	83.5
P612	6-1/2	1-1/2 x 1/4	80.5
P634	6-3/4	1-3/4 x 1/8	74.7
P7	7	1-3/4 x 1/8	68.1
W BUSHINGS			
W414MPB	4-1/4	-	247.0
W478MPB	4-7/8	-	234.0
W514MPB	5-1/4	-	225.0
W578MPB	5-7/8	-	209.0
W612MPB	6-1/2	-	191.0
W714MPB	7-1/4	-	167.0
W734	7-3/4	2 x 1/4	150.0
W812	8-1/2	2 x 1/4	120.0
S BUSHINGS			
S6MPB	6	-	445.0
S8MPB	8	-	356.0
S9MPB	9	-	301.0

MPB bushings are unsplit.

* Approximate weight in lbs.

Sure-Grip® Bushings With Metric Bore and Keyseat

Bore And Key Seat Dimensions

DIMENSIONS (In mm)

Product No.	Bore (mm)	Key ■	Wt. (*)
QT BUSHINGS			
QT14MM	14	5 x 5	.6
QT15MM	15	5 x 5	.6
QT16MM	16	5 x 5	.6
QT18MM	18	6 x 6	.6
QT19MM	19	6 x 6	.6
QT20MM	20	6 x 6	.6
QT22MM	22	6 x 6	.6
QT24MM	24	8 x 7	.6
QT25MM	25	8 x 7	.6
QT28MM	28	8 x 7	.6
QT30MM	30	8 x 7	.6
QT32MM	32	10 x 6†	.6
QT35MM	35	10 x 6†	.6
QT38MM	38	10 x 6†	.6
JA BUSHINGS			
JA15MM	15	5 x 5	.8
JA16MM	16	5 x 5	.8
JA19MM	19	6 x 6	.8
JA20MM	20	6 x 6	.8
JA24MM	24	8 x 6†	.8
JA25MM	25	8 x 6†	.8
JA28MM	28	8 x 5†	.8
SH BUSHINGS			
SH24MM	24	8 x 7	.9
SH25MM	25	8 x 7	.9
SH28MM	28	8 x 7	.9
SH30MM	30	8 x 7	.8
SH32MM	32	10 x 8	.8
SH35MM	35	10 x 8	.7
SDS BUSHINGS			
SDS24MM	24	8 x 7	1.5
SDS25MM	25	8 x 7	1.5
SDS28MM	28	8 x 7	1.4
SDS30MM	30	8 x 7	1.4
SDS32MM	32	10 x 8	1.3
SDS35MM	35	10 x 8	1.2
SDS38MM	38	10 x 8	1.1
SDS40MM	40	12 x 8	1.1
SDS42MM	42	12 x 8	1.0
SD BUSHINGS			
SD24MM	24	8 x 7	1.8
SD25MM	25	8 x 7	1.8
SD28MM	28	8 x 7	1.7
SD30MM	30	8 x 7	1.7
SD32MM	32	10 x 8	1.6
SD35MM	35	10 x 8	1.5
SD38MM	38	10 x 8	1.4
SD40MM	40	12 x 8	1.3
SD42MM	42	12 x 8	1.2

Product No.	Bore (mm)	Key ■	Wt. (*)
SK BUSHINGS			
SK24MM	24	8 x 7	3.3
SK25MM	25	8 x 7	3.3
SK28MM	28	8 x 7	3.2
SK30MM	30	8 x 7	3.2
SK32MM	32	10 x 8	3.1
SK35MM	35	10 x 8	3.0
SK38MM	38	10 x 8	2.9
SK40MM	40	12 x 8	3.6
SK42MM	42	12 x 8	2.7
SK45MM	45	14 x 9	2.6
SK48MM	48	14 x 9	2.4
SK50MM	50	14 x 9	2.3
SK55MM	55	16 x 10	2.0
SF BUSHINGS			
SF28MM	28	8 x 7	4.7
SF30MM	30	8 x 7	4.6
SF32MM	32	10 x 8	4.5
SF35MM	35	10 x 8	4.4
SF38MM	38	10 x 8	4.2
SF40MM	40	12 x 8	4.2
SF42MM	42	12 x 8	4.1
SF45MM	45	14 x 9	3.9
SF48MM	48	14 x 9	3.7
SF50MM	50	14 x 9	3.6
SF55MM	55	16 x 10	3.2
SF60MM	60	18 x 11	3.0
SF65MM	65	18 x 8 †	2.6
E BUSHINGS			
E35MM	35	10 x 8	10.2
E38MM	38	10 x 8	10.0
E40MM	40	12 x 8	9.9
E42MM	42	12 x 8	9.8
E45MM	45	14 x 9	9.6
E48MM	48	14 x 9	9.3
E50MM	50	14 x 9	9.2
E55MM	55	16 x 10	8.6
E60MM	60	18 x 11	8.1
E65MM	65	18 x 11	7.6
E70MM	70	20 x 12	7.1
E75MM	75	20 x 12	6.9
E80MM	80	22 x 11†	6.3

Product No.	Bore (mm)	Key ■	Wt. (*)
F BUSHINGS			
F45MM	45	14 x 9	16.2
F48MM	48	14 x 9	16.0
F50MM	50	14 x 9	15.8
F55MM	55	16 x 10	15.0
F60MM	60	18 x 11	14.3
F65MM	65	18 x 11	13.7
F70MM	70	20 x 12	12.9
F75MM	75	20 x 12	12.1
F80MM	80	22 x 14	11.2
F85MM	85	22 x 14	10.6
F90MM	90	25 x 14	9.7
J BUSHINGS			
J50MM	50	14 x 9	26.5
J55MM	55	16 x 10	25.6
J60MM	60	18 x 11	24.7
J65MM	65	18 x 11	23.9
J70MM	70	20 x 12	23.0
J75MM	75	20 x 12	21.9
J80MM	80	22 x 14	20.9
J85MM	85	22 x 14	19.3
J90MM	90	25 x 14	18.1
J95MM	95	25 x 14	16.8
J100MM	100	28 x 16	16.5
M BUSHINGS			
M80MM	80	22 x 14	55.0
M90MM	90	25 x 14	51.2
M100MM	100	28 x 16	46.9
M120MM	120	32 x 18	37.0
N BUSHINGS			
N100MM	100	28 x 16	72.3
N120MM	120	32 x 18	60.2
P BUSHINGS			
P150MM	150	36 x 20	95.8

Approximate weight in lbs.

■ The metric system does not refer to keyseat or keyway dimensions as does the English system; instead, dimensions are given for the key itself, which is rectangular in shape and not square as in the English system. This meets ISO standards.

† SHALLOW KEY FURNISHED

SAE Sure-Grip® L Series Flangeless Bushings

Bush.	Torque Capacity (In.-Lbs.)	Type Material	Max. Bore (In.)	Max. Bore (In.)	DIMENSIONS IN INCHES		Bolt Circle	Cap Screws Required
					B	F		
SKL	7,000	D.I.	1-15/16	50	2.8125	1-1/8	2-3/8	3-1/4 x 1-3/4
SFL	11,000	D.I.	2-3/8	60	3.1250	1-1/8	2-3/4	4-1/4 x 1-3/4
EL	20,000	D.I.	2-7/8	73	3.8340	1-1/2	3-3/8	4-5/16 x 1-3/4
FL	45,000	D.I.	3-1/8	80	4.4375	2-3/8	3-3/4	4-3/8 x 2

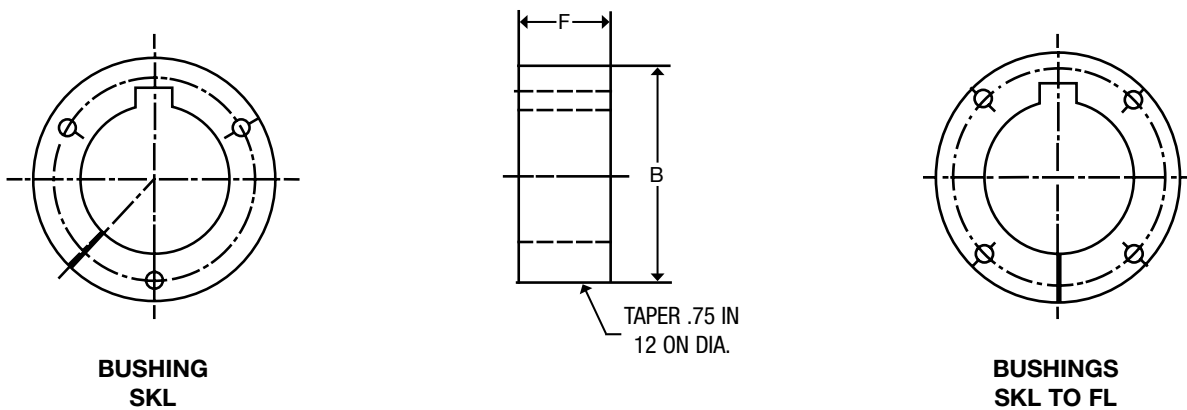

Patent No. 5304101

To Install:

IMPORTANT: DO NOT USE LUBRICANTS IN THIS INSTALLATION

1. Inspect shafts, bushing, and mating hub. Remove all nicks, paint, dirt, grease, etc. from mating surfaces.
2. Place key in shaft's keyseat.
3. Slide bushing onto shaft and key. **Small End of Taper Must Be Outboard.**
4. Slide tapered mating hub over bushing. Align (1) the shaft key with one of the slots in the mating hub and (2) the drilled holes in mating hub with the threaded holes in the bushing.
5. Put lockwashers on cap screws and insert one cap screw thru each drilled hole in the mating hub and into the threaded hole in the bushing.
6. **Use a Torque Wrench.** Tighten all cap screws evenly and progressively in rotation. Torque around all the cap screws as often as necessary until the listed torque value remains on each cap screw.

To Remove:

1. Loosen and remove all cap screws from assembly.
2. Install one cap screw in each threaded hole in the mating hub.
3. Evenly torque each cap screw in rotation to force the mating hub off the bushing.

Bushing	Torque (Ft.-Lbs.)
SKL	15
SFL	15
EL	30
FL	55

CAUTION
The use of lubricants or excessive wrench torques may cause hub stresses high enough to break the mating hub!

SAE Sure-Grip® L Series Flangeless Bushings

Bore And Keyseat Dimensions

DIMENSIONS (In Inches)

Product No.	Bore	Key Seat	Wt. (*)
SKL BUSHINGS			
SKLMPB	1/2	MPB*	1.7
SKL12	1/2	1/8 x 1/16	1.7
SKL58	5/8	3/16 x 3/32	1.7
SKL34	3/4	3/16 x 3/32	1.6
SKL78	7/8	3/16 x 3/32	1.6
SKL15/16	15/16	1/4 x 1/8	1.6
SKL1	1	1/4 x 1/8	1.6
SKL118	1-1/8	1/4 x 1/8	1.5
SKL1316	1-3/16	1/4 x 1/8	1.4
SKL114	1-1/4	1/4 x 1/8	1.4
SKL1516	1-5/16	5/16 x 5/32	1.3
SKL138	1-3/8	5/16 x 5/32	1.3
SKL1716	1-7/16	3/8 x 3/16	1.2
SKL112	1-1/2	3/8 x 3/16	1.2
SKL1916	1-9/16	3/8 x 3/16	1.2
SKL158	1-5/8	3/8 x 3/16	1.1
SKL11116	1-11/16	3/8 x 3/16	1.1
SKL134	1-3/4	3/8 x 3/16	1.0
SKL11316	1-13/16	1/2 x 1/4	1.0
SKL178	1-7/8	1/2 x 1/4	.9
SKL11516	1-15/16	1/2 x 1/4	.8
SFL BUSHINGS			
SFLMPB	1/2	MPB*	2.1
SFL12	1/2	1/8 x 1/16	2.1
SFL58	5/8	3/16 x 3/32	2.1
SFL34	3/4	3/16 x 3/32	2.0
SFL78	7/8	3/16 x 3/32	2.0
SFL15/16	15/16	1/4 x 1/8	2.0
SFL1	1	1/4 x 1/8	2.0
SFL118	1-1/8	1/4 x 1/8	1.9
SFL1316	1-3/16	1/4 x 1/8	1.8
SFL114	1-1/4	1/4 x 1/8	1.8
SFL1516	1-5/16	5/16 x 5/32	1.7
SFL138	1-3/8	5/16 x 5/32	1.7
SFL1716	1-7/16	3/8 x 3/16	1.6

Product No.	Bore	Key Seat	Wt. (*)
SFL BUSHINGS			
SFL112	1-1/2	3/8 x 3/16	1.6
SFL1916	1-9/16	3/8 x 3/16	1.5
SFL158	1-5/8	3/8 x 3/16	1.5
SFL11116	1-11/16	3/8 x 3/16	1.4
SFL134	1-3/4	3/8 x 3/16	1.4
SFL11316	1-13/16	1/2 x 1/4	1.4
SFL178	1-7/8	1/2 x 1/4	1.3
SFL11516	1-15/16	1/2 x 1/4	1.3
SFL2	2	1/2 x 1/4	1.2
SFL218	2-1/8	1/2 x 1/4	1.1
SFL2316	2-3/16	1/2 x 1/4	1.0
SFL214	2-1/4	1/2 x 1/4	1.0
SFL2516	2-5/16	5/8 x 5/16	.9
SFL238	2-3/8	5/8 x 5/16	.9
EL BUSHINGS			
ELMPB	7/8	MPB*	4.1
EL78	7/8	3/16 x 3/32	4.1
EL15/16	15/16	1/4 x 1/8	4.0
EL1	1	1/4 x 1/8	3.9
EL118	1-1/8	1/4 x 1/8	3.8
EL1316	1-3/16	1/4 x 1/8	3.8
EL114	1-1/4	1/4 x 1/8	3.7
EL1516	1-5/16	5/16 x 5/32	3.6
EL138	1-3/8	5/16 x 5/32	3.6
EL1716	1-7/16	3/8 x 3/16	3.5
EL112	1-1/2	3/8 x 3/16	3.5
EL1916	1-9/16	3/8 x 3/16	3.4
EL158	1-5/8	3/8 x 3/16	3.4
EL11116	1-11/16	3/8 x 3/16	3.3
EL134	1-3/4	3/8 x 3/16	3.2
EL11316	1-13/16	1/2 x 1/4	3.2
EL178	1-7/8	1/2 x 1/4	3.1
EL11516	1-15/16	1/2 x 1/4	3.0
EL2	2	1/2 x 1/4	3.0
EL218	2-1/8	1/2 x 1/4	2.9
EL2316	2-3/16	1/2 x 1/4	2.8
EL214	2-1/4	1/2 x 1/4	2.7
EL2516	2-5/16	5/8 x 5/16	2.6
EL238	2-3/8	5/8 x 5/16	2.5
EL2716	2-7/16	5/8 x 5/16	2.4

Product No.	Bore	Key Seat	Wt. (*)
EL BUSHINGS			
EL212	2-1/2	5/8 x 5/16	2.3
EL2916	2-9/16	5/8 x 5/16	2.3
EL258	2-5/8	5/8 x 5/16	2.2
EL21116	2-11/16	5/8 x 5/16	2.1
EL234	2-3/4	5/8 x 5/16	2.0
EL21316	2-13/16	3/4 x 3/8	1.9
EL278	2-7/8	3/4 x 3/8	1.8
FL BUSHINGS			
FLMPB	1	MPB*	8.5
FL1	1	1/4 x 1/8	8.5
FL118	1-1/8	1/4 x 1/8	8.3
FL1316	1-3/16	1/4 x 1/8	8.2
FL114	1-1/4	1/4 x 1/8	8.1
FL138	1-3/8	5/16 x 5/32	8.0
FL1716	1-7/16	3/8 x 3/16	7.9
FL112	1-1/2	3/8 x 3/16	7.8
FL1916	1-9/16	3/8 x 3/16	7.6
FL158	1-5/8	3/8 x 3/16	7.5
FL11116	1-11/16	3/8 x 3/16	7.4
FL134	1-3/4	3/8 x 3/16	7.3
FL178	1-7/8	1/2 x 1/4	7.1
FL11516	1-15/16	1/2 x 1/4	7.0
FL2	2	1/2 x 1/4	6.7
FL218	2-1/8	1/2 x 1/4	6.6
FL2316	2-3/16	1/2 x 1/4	6.5
FL214	2-1/4	1/2 x 1/4	6.4
FL2516	2-5/16	5/8 x 5/16	6.3
FL238	2-3/8	5/8 x 5/16	6.2
FL2716	2-7/16	5/8 x 5/16	6.1
FL212	2-1/2	5/8 x 5/16	5.9
FL2916	2-9/16	5/8 x 5/16	5.7
FL258	2-5/8	5/8 x 5/16	5.6
FL21116	2-11/16	5/8 x 5/16	5.4
FL234	2-3/4	5/8 x 5/16	5.3
FL21316	2-13/16	3/4 x 3/8	5.1
FL278	2-7/8	3/4 x 3/8	4.9
FL21516	2-15/16	3/4 x 3/8	4.8
FL3	3	3/4 x 3/8	4.6
FL318	3-1/8	3/4 x 3/8	4.5

* Approximate weight in lbs.
MPB bushings are unsplit.

SAE Sure-Grip® Short Bushings

Dimensions

Sure-Grip bushings are designed to transmit the rated torque capacity listed in the table below when the cap screws are tightened as indicated. The bushings are stocked in all popular bore sizes, including metric bores, within bore range for a particular bushing.

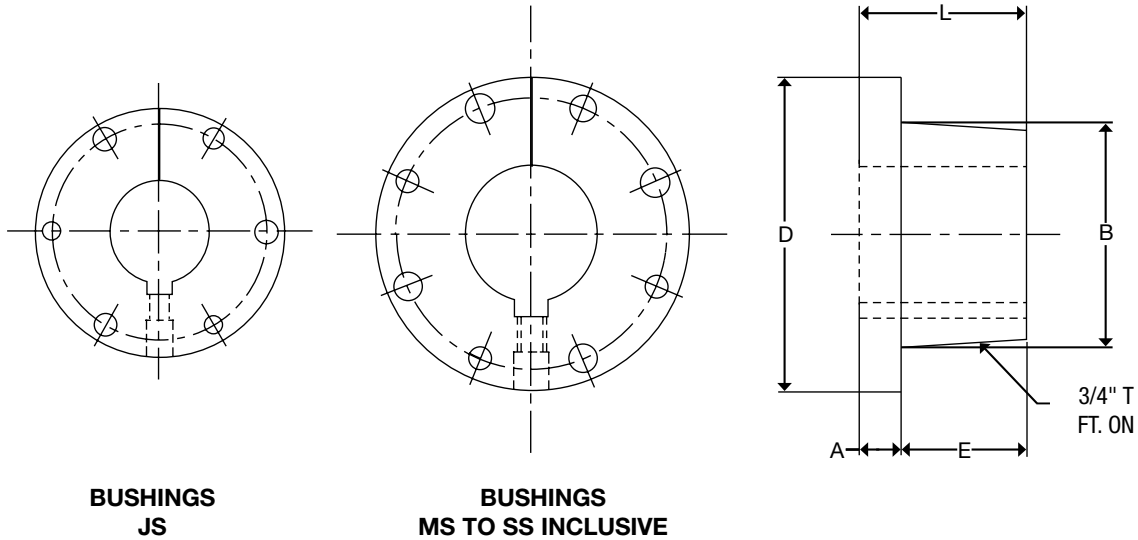

SURE-GRIP SHORT BUSHING TORQUE RATINGS AND DIMENSIONS

Bush.	Torque Capacity (In.-Lbs.)	Max. Bore	DIMENSIONS IN INCHES					Bolt Circle	Cap Screws Required
			A	B	D	E	L		
JS	35,000	4-1/2	1	5.1484	7-1/4	2-3/8	3-3/8	6-1/4	3-5/8 x 2-1/2
MS	85,000	5-1/2	1-3/16	6.500	9-1/8	3-5/8	4-13/16	7-7/8	4-3/4 x 3
NS	100,000	6	1-1/2	7.000	10	4-1/2	6	8-1/2	4-7/8 x 3-1/2
PS	170,000	7	1-1/2	8.250	11-3/4	5	6-1/2	10	4 - 1 x 4
WS	250,000	8-1/2	1-3/4	10.437	15	5-1/2	7-1/4	12-3/4	4 - 1-1/8 x 5
SS	410,000	10	2	12.125	17-3/4	6-3/4	8-3/4	15	5 - 1-1/4 x 5

Setscrew not standard – Available as alteration.

See page A1-11 for Bore and Keyseat information and weights.

SAE Sure-Grip® Short Bushings

Bore and Key Seat Dimensions

DIMENSIONS (In Inches)

Product No.	Bore	Key Seat	Wt. (*)
JS BUSHINGS			
JS2716	2- 7/16	5/8 X 5/16	20.0
JS21516	2-15/16	3/4 X 3/8	18.1
JS3716	3- 7/16	7/8 X 7/16	15.9
JS31516	3-15/16	1 X 1/4	14.3
JS4716	4- 7/16	1 X 1/8	11.5
MS BUSHINGS			
MS3716	3- 7/16	7/8 X 7/16	41.2
MS31516	3-15/16	1 X 1/2	37.3
MS4716	4- 7/16	1 X 1/2	33.3
MS41516	4-15/16	1-1/4 X 1/4	30.9
MS5716	5- 7/16	1-1/4 X 1/4	25.9
NS BUSHINGS			
NS31516	3-15/16	1 X 1/2	66.3
NS4716	4- 7/16	1 X 1/2	52.5
NS41516	4-15/16	1-1/4 X 5/8	46.5
NS5716	5- 7/16	1-1/4 X 1/4	43.9
NS51516	5-15/16	1-1/2 X 1/8	39.0
NS6	6	1-1/2 X 1/8	38.8

* Approximate weight in lbs.

Product No.	Bore	Key Seat	Wt. (*)
PS BUSHINGS			
PS41516	4-15/16	1-1/4 X 5/8	88.3
PS5716	5- 7/16	1-1/4 X 5/8	81.3
PS51516	5-15/16	1-1/2 X 3/4	78.4
PS6	6	1-1/2 X 3/4	77.4
PS6716	6- 7/16	1-1/2 X 1/2	70.0
PS612	6- 1/2	1-1/2 X 1/2	69.0
PS61516	6-15/16	1-3/4 X 1/8	61.3
PS7	7	1-3/4 X 1/8	60.4
WS BUSHINGS			
WS5716	5- 7/16	1-1/4 X 5/8	172.3
WS51516	5-15/16	1-1/2 X 3/4	161.1
WS6716	6- 7/16	1-1/2 X 3/4	155.0
WS612	6- 1/2	1-1/2 X 3/4	153.0
WS61516	6-15/16	1-3/4 X 3/4	140.0
WS7	7	1-3/4 X 3/4	139.0
WS712	7- 1/2	1-3/4 X 3/4	137.0
WS71516	7-15/16	2 X 3/4	126.9
WS8	8	2 X 3/4	124.0
WS8716	8- 7/16	2 X 1/4	107.3
WS812	8- 1/2	2 X 1/4	105.0

Double Adjustment Tensioner Belt Drive Or Chain Tensioner

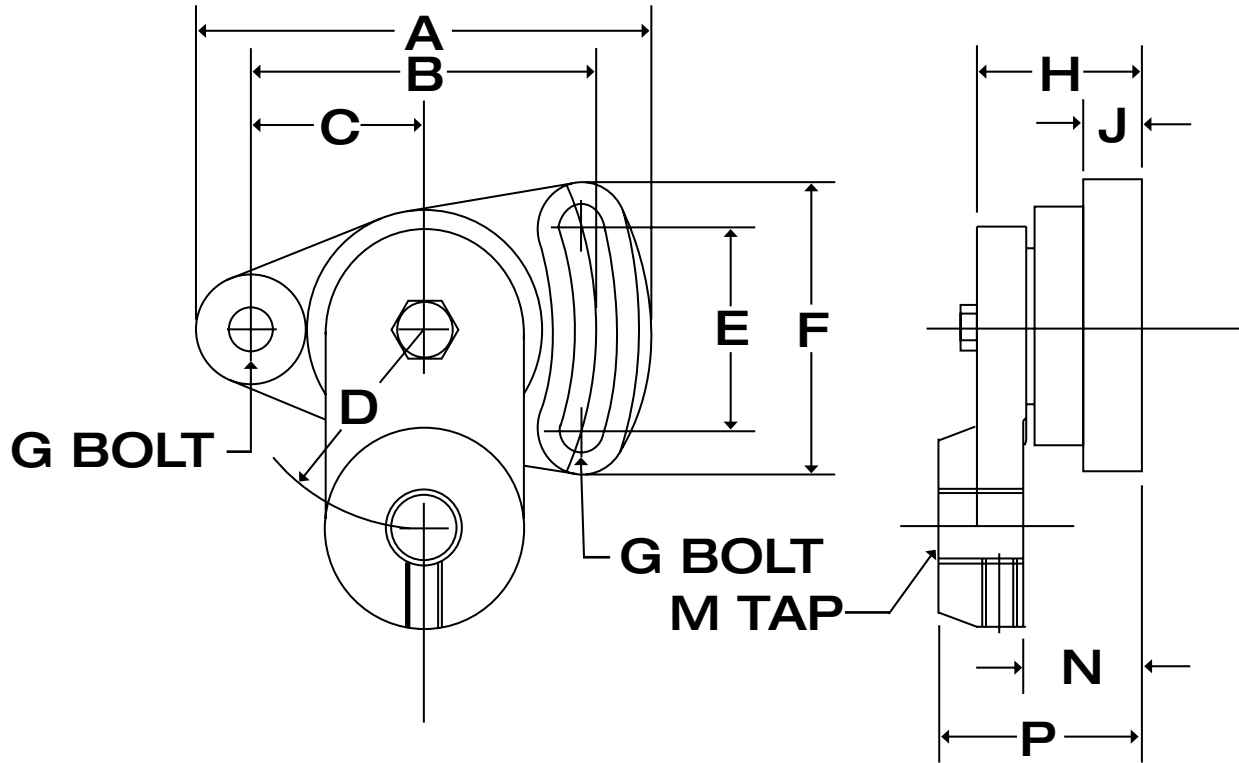

Product Number	DIMENSIONS IN INCHES												Weight Lbs.
	A	B	C	D	E	F	G	H	J	M	N	P	
DAM	4.62	3.50	1.75	2.00	2.06	3.06	.375	1.63	.62	3/4-10	1.16	2.01	3.0
DAL	6.94	5.25	2.63	5.00	3.00	4.56	.625	2.38	.88	1"-8	1.68	2.94	9.5

The Double Adjustment tensioner (Type DA) permits a full 360 degree rotation of the idler. A second adjustment is obtained by the long slot in the base. The arm is locked in place with an ingenious use of a tapered fit. Tensioning of a drive should follow the installation guideline for the type of drive in question.

FOR USE WITH SHEAVES, PULLEYS, SPROCKETS, GEARS OR OTHER PRODUCTS DESIGNED FOR QD-TYPE BUSHINGS



Wood's Sure-Grip Idler Bushings are designed to accommodate stock V-belt sheaves, flat-belt or Timing-belt pulleys, roller or silent chain sprockets, gears or other products that use QD*-type bushings. They are equipped with two, permanently lubricated, ball-bearing units for long, smooth, trouble-free performance. Installation is made simply by slipping the threaded shaft through a hole bored in the support structure and tightening the locking nut. Sheaves, pulleys or other products can be removed without dismantling the idler bushing. These idler units are available with SH, SD, SK, SF or E Sure-Grip bushings. Wood's Sure-Grip bushings are of the most widely used, tapered, interchangeable type.

* U.S.T.M. Reg. No. 403,470 Can. T.M. Reg. No. 113,711

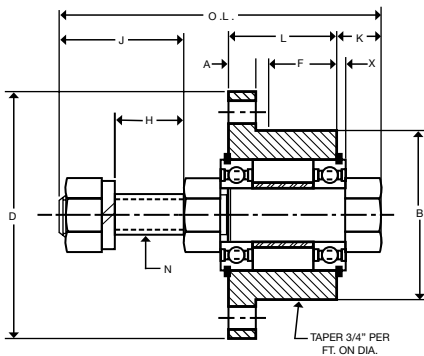

Product No.	DIMENSIONS IN INCHES											Wt. (Lbs.)
	A	B	D	F	H	J	K	L	N	O.L.	X	
SHBB	0.38	1.871	2.69	0.75	.53	0.98	0.44	1.25	1/2-13NC	3.13	.12	1.5
SDBB	0.44	2.187	3.19	1.25	.72	1.17	0.44	1.81	1/2-13NC	3.88	.12	2.5
SDBB58	0.44	2.187	3.19	1.25	.57	1.12	0.44	1.81	5/8-11NC	3.88	.12	2.7
SKBB	0.50	2.812	3.88	1.25	.85	1.42	0.62	1.88	3/4-10NC	4.50	.14	4.5
SFBB	0.50	3.125	4.63	1.38	.73	1.29	0.62	2.00	3/4-10NC	4.50	.14	8.0
SFBB1	0.50	3.125	4.63	1.38	1.08	1.91	0.62	2.00	1"-8NC	5.25	.14	8.6
EBB	0.75	3.834	6.00	1.63	1.11	2.30	0.97	2.63	1-3/8-6NC	6.88	.19	12.0

Equivalent Load Rating (lbs.)

Hours Life	Product No.	Basic Rating	RPM					
			500	1000	2000	3000	4000	5000
1000	SHBB	3320	1068	848	673	588	534	496
	SKBB	4860	1564	1241	985	861	782	726
	SFBB	4860	1564	1241	985	861	782	726
	EBB	10100	3250	2580	2048	1789	1625	1509
	SHBB	3320	848	673	534	467	424	394
2000	SDBB	3320	848	673	534	467	424	394
	SKBB	4860	1241	985	782	683	621	576
	SFBB	4860	1241	985	782	683	621	576
	EBB	10100	2580	2048	1625	1420	1290	1197
	SHBB	3320	588	467	370	324	294	273
6000	SDBB	3320	588	467	370	324	294	273
	SKBB	4860	861	683	542	474	430	400
	SFBB	4860	861	683	542	474	430	400
	EBB	10100	1789	1420	1127	984	894	830

Note: The basic rating is the maximum dynamic radial load which will allow a 90% survival rate when running at 33-1/3 RPM for 500 hours.

$$\text{Equivalent Rating} = 3 \sqrt{\frac{\text{Basic Rating}}{\text{Hours} \times 60 \times \text{RPM}/1,000,000}}$$

$$\text{Hours} = \frac{\text{Basic Rating}^3 \times 1,000,000}{\text{Load (Lbs.)}^3 \times 60 \times \text{RPM}}$$

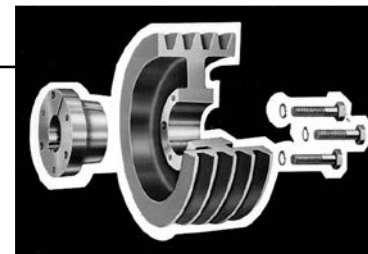

Installation Instructions

The Sure-Grip tapered, QD-type interchangeable bushing offers flexible and easy installation while providing exceptional holding power. To ensure that the bushing performs as specified, it must be installed properly.

Before beginning, make sure the correct size and quantity of parts are available for the installation. The bushing has been manufactured to accept a setscrew over the key and its use is optional. It is packaged with the hardware on sizes SH to M and loosely installed in the bushing on sizes N to S.

To Install:

IMPORTANT:

DO NOT USE LUBRICANTS IN THIS INSTALLATION!

1. Inspect the tapered bore of the sheave and the tapered surface of the bushing. Any paint, dirt, oil, or grease **MUST** be removed.
2. Select the type of mounting (See Fig. 1 or 2) that best suits your application.

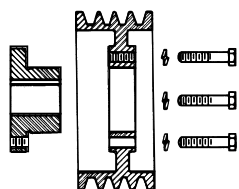

Fig. 1

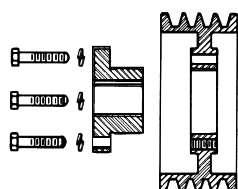
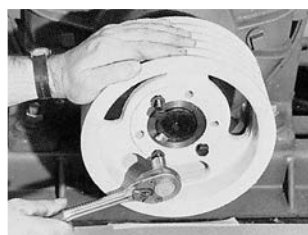

Fig. 2

3. **STANDARD MOUNTING:** Install shaft key. (Note: If key was furnished with bushing, you must use that key.) Install bushing on clean shaft, flange end first. If bushing will not freely slide on the shaft, insert a screwdriver or similar object into the flange sawcut to act as a wedge to open the bushing's bore. **Caution: Excessive wedging will split the bushing.** If using the setscrew, tighten it just enough to prevent the bushing from sliding on the shaft. **Caution: Do not over-tighten setscrew!** Slide sheave into position on bushing aligning the drilled holes in the sheave with the tapped holes in the bushing flange. (Note: Install M thru S bushings so that the two tapped holes in the sheave are located as far away as possible from the bushing's sawcut.) Loosely thread the cap screws with lockwashers into the assembly. **DO NOT USE LUBRICANT ON THE CAP SCREWS!**
4. **REVERSE MOUNTING:** With large end of the taper out, slide sheave onto shaft as far as possible. Install shaft key. (See shaft key note in #3 above.) Install bushing onto shaft so tapered end will mate with sheave. (See wedging note in #3 above.) If using the setscrew, tighten it enough to prevent the bushing from sliding on the shaft. **Caution: Do not over-tighten setscrew!** Pull the sheave up on the bushing, aligning the drilled holes in the bushing flange with the tapped holes in the sheave. Loosely thread the cap screws with lockwashers into the assembly. **DO NOT USE LUBRICANT ON THE CAP SCREWS!**
5. Using a torque wrench, tighten all cap screws evenly and progressively in rotation to the torque value in Table. There must be a gap between the bushing flange and sheave hub when installation is complete. **DO NOT OVER-TORQUE! DO NOT ATTEMPT TO CLOSE GAP BETWEEN BUSHING FLANGE AND SHEAVE HUB!**

To Remove:

1. Relieve drive tension by shortening the center distance between driver and driven sheaves.
2. Lift off belts.
3. Loosen and remove cap screws. If the bushings have keyway setscrews, loosen them.
4. As shown below, insert cap screws (three in JA through J bushings, two in QT and M thru W bushings and four in S bushing) in tapped removal holes and progressively tighten each one until mating part is loose on bushing. (Exception: If mating part is installed with cap screw heads next to motor, with insufficient room to insert screws in tapped holes, loosen cap screws and use wedge between bushing flange and mating part.)
5. Remove mating part from bushing and, if necessary, bushing from shaft.



SURE-GRIP BUSHINGS SCREW TIGHTENING INFORMATION

Tapered Bushing	Size & Thread of Cap Screw	Ft.-Lbs. To Apply With Torque Wrench
QT	1/4 x 20	9
JA	No. 10 - 24	5
SH-SDS-SD	1/4 - 20	9
SK	5/16 - 18	15
SF	3/8 - 16	30
E	1/2 - 13	60
F	9/16 - 12	110
J	5/8 - 11	135
JS	5/8 - 11	100
M	3/4 - 10	225
MS	3/4 - 10	150
N	7/8 - 9	300
NS	7/8 - 9	200
P	1 - 8	450
PS	1 - 8	300
W	1-1/8 - 7	600
WS	1-1/8 - 7	400
S	1-1/4 - 7	750
SS	1-1/4 - 7	500

CAUTION: The tightening force on the screws is multiplied many times by the wedging action of the tapered surface. If extreme tightening force is applied, or if a lubricant is used, bursting pressures will be created in the hub of the mating part.

Wood's Metric Sure-Grip® QD Bushings (with metric hardware)

A2



- **Provide a True Clamp Fit**
- **Are Easy to Install and Remove**
- **Permit Four-Way Mounting**

Metric Sure-Grip® Bushings

Features

Sure-Grip® “Quick Detachable” bushings are easy to install and remove. They are split through flange and taper to provide a true clamp on the shaft that is the equivalent of a shrink fit. All sizes except JA and QT have a setscrew over the key to help

maintain the bushing’s position on the shaft until the cap screws are securely tightened. Sure-Grip bushings have a very gradual taper (3/4-inch taper per ft. on the diameter) which is about half the inclined angle of many other bushings. The result is the Sure-Grip securely clamps the shaft, with twice the force of those competitive bushings, to provide extreme holding power.

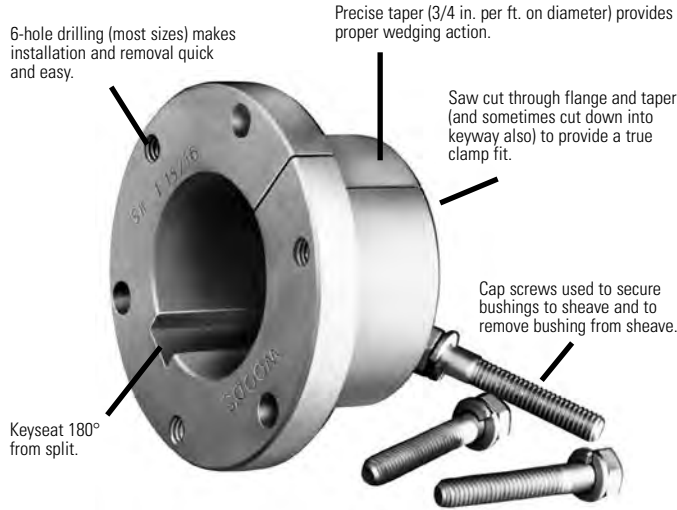

Versatile Sure-Grip bushings permit the mounting of the same mating part on shafts of different diameters, and the mounting of different sheaves on the same shaft using the same bushing. Their interchangeability extends through sheaves, pulleys, timing pulleys, sprockets, flexible and rigid couplings, made-to-order items by Wood’s, and to product lines of several other mechanical power transmission manufacturers.

Sure-Grip bushings are manufactured with the drilled and tapped holes located at a precise distance from the keyseat; thus, a wide mating part having a bushing in each end can be mounted on a common shaft with the two keyways in line. This feature not only facilitates installation but also permits both bushings to carry an equal share of the load.

STANDARD MOUNTING

REVERSE MOUNTING

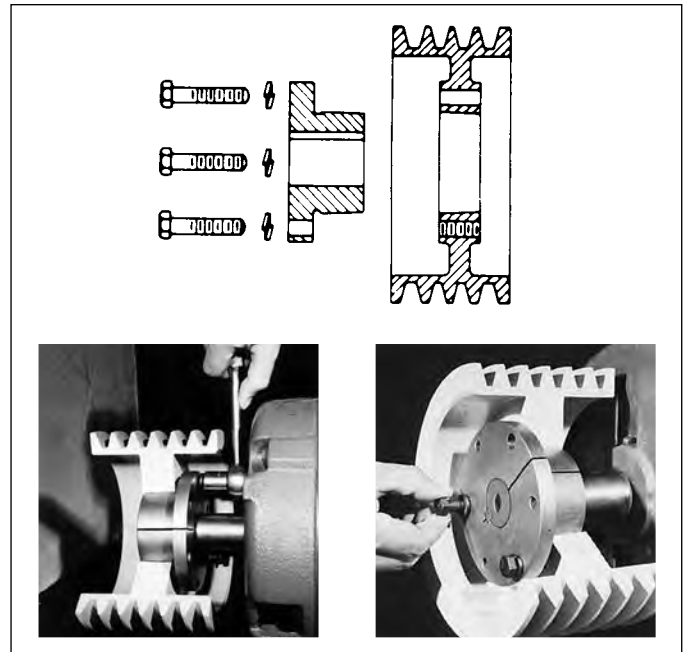
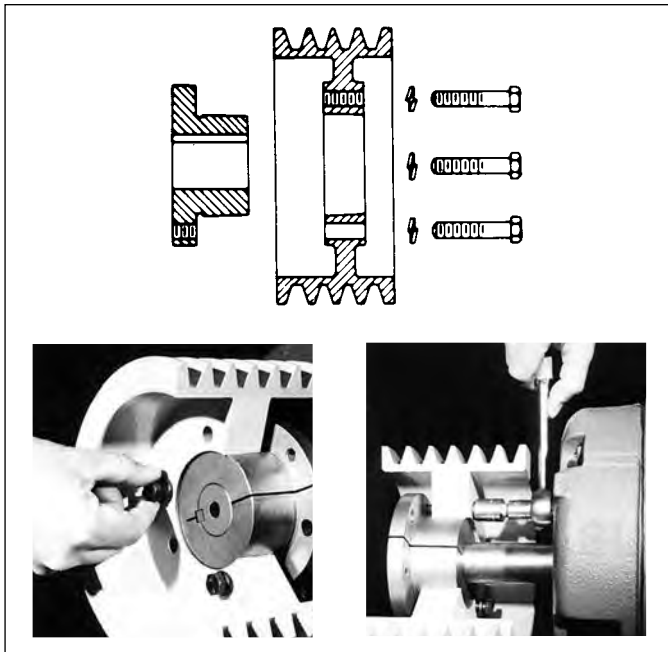

1. Cap screws from outside through drilled holes in the mating part and into threaded holes in the bushing flange located on the inside of the assembly. Or the complete assembly reversed on the shaft and;
2. Cap screws from inside through drilled holes in the mating part and into threaded holes in the bushing flange located on the outside of the assembly.
3. Cap screws from inside through drilled holes in the bushing flange located on the inside of the assembly and into threaded holes in the mating part.
4. Cap screws from outside through drilled holes in the bushing flange located on the outside of the assembly and into threaded holes in the mating part.

Dimensions

Sure-Grip bushings are designed to transmit the rated torque capacity listed in the table below when the cap screws are tightened as indicated. The bushings are stocked in all popular bore sizes, including metric bores, within the bore range for a particular bushing.

NOTE: Mating hub must have metric drilling.

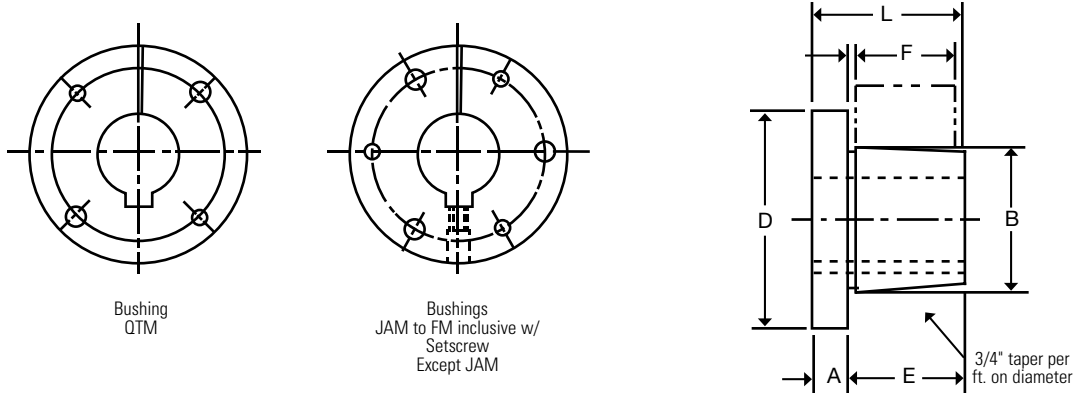

SURE-GRIP BUSHING TORQUE RATINGS AND DIMENSIONS

Metric Bushing	Torque Capacity (NM)	Max. Bore (Note 1)	DIMENSIONS IN MILLIMETERS						Cap Screw Bolt Circle	Screws Required
			A	B	D	E	F*	L		
QTM	198	30	6.4	41.3	63.5	25.4	22.2	31.8	50.8	2 - M6
JAM	198	23	7.9	34.9	50.8	17.5	14.3	25.4	42.1	3 - M5
SHM	395	36	9.5	47.5	68.3	22.2	20.6	31.8	57.2	3 - M6
SDSM	565	42	11.1	55.6	81.0	22.2	19.1	33.3	68.3	3 - M6
SDM	565	42	11.1	55.6	81.0	34.9	31.8	46.0	68.3	3 - M6
SKM	791	56	12.7	71.4	98.4	34.9	31.8	47.6	84.1	3 - M8
SFM	1243	63	12.7	79.4	117.5	38.1	31.8	50.8	98.4	3 - M10
EM	2260	78	19.1	97.4	152.4	47.6	41.3	66.7	127.0	3 - M12
FM	4519	90	20.6	112.7	168.3	71.4	63.5	92.1	142.9	3 - M16

* Mating hub length.

1. MAX MM BORE WITH STANDARD KEYSEAT.

See pages A2-4 for Bore and Keyseat information and weights.

Metric Sure-Grip® Bushings

Bore And Keyseat Dimensions

Product No.	Bore (mm)	Key	Wt.
QTM BUSHINGS			
QTMMPB	10	NONE	0.6
QTM10MM	10	4 x 4	0.6
QTM11MM	11	4 x 4	0.6
QTM14MM	14	5 x 5	0.6
QTM15MM	15	5 x 5	0.6
QTM16MM	16	5 x 5	0.6
QTM19MM	19	6 x 6	0.6
QTM20MM	20	6 x 6	0.6
QTM24MM	24	8 x 7	0.6
QTM25MM	25	8 x 7	0.6
QTM28MM	28	8 x 7	0.6
QTM30MM	30	8 x 7	0.6
QTM32MM	32	10 x 6†	0.6
QTM38MM	38	10 x 6†	0.6
JAM BUSHINGS			
JAMMPB	10	NONE	0.8
JAM10MM	10	4 x 4	0.8
JAM11MM	11	4 x 4	0.8
JAM14MM	14	5 x 5	0.8
JAM15MM	15	5 x 5	0.8
JAM19MM	19	6 x 6	0.8
JAM20MM	20	6 x 6	0.8
JAM24MM	24	8 x 6†	0.8
JAM25MM	25	8 x 6†	0.8
JAM28MM	28	8 x 5†	0.8
SHM BUSHINGS			
SHMMPB	10	NONE	1.1
SHM10MM	10	4 x 4	1.1
SHM11MM	11	4 x 4	1.1
SHM14MM	14	5 x 5	1.1
SHM15MM	15	5 x 5	1.1
SHM19MM	19	6 x 6	1.0
SHM20MM	20	6 x 6	1.0
SHM24MM	24	8 x 7	1.0
SHM25MM	25	8 x 7	1.0
SHM28MM	28	8 x 7	0.9
SHM30MM	30	8 x 7	0.8
SHM32MM	32	10 x 8	0.8
SHM35MM	35	10 x 8	0.7
SHM38MM	38	10 x 7†	0.7
SHM40MM	40	12 x 6†	0.6

Product No.	Bore (mm)	Key	Wt.
SDSM BUSHINGS			
SDSMMPB	10	NONE	1.7
SDSM15MM	15	5 x 5	1.6
SDSM19MM	19	6 x 6	1.6
SDSM20MM	20	6 x 6	1.6
SDSM24MM	24	8 x 7	1.5
SDSM25MM	25	8 x 7	1.5
SDSM28MM	28	8 x 7	1.4
SDSM30MM	30	8 x 7	1.4
SDSM32MM	32	10 x 8	1.4
SDSM35MM	35	10 x 8	1.2
SDSM38MM	38	10 x 8	1.1
SDSM40MM	40	12 x 8	1.0
SDSM42MM	42	12 x 8	1.0
SDSM48MM	48	14 x 7†	0.9
SDM BUSHINGS			
SDMMPB	15	NONE	2.0
SDM15MM	15	5 x 5	2.0
SDM19MM	19	6 x 6	1.9
SDM20MM	20	6 x 6	1.9
SDM24MM	24	8 x 7	1.9
SDM25MM	25	8 x 7	1.9
SDM28MM	28	8 x 7	1.7
SDM30MM	30	8 x 7	1.7
SDM35MM	35	10 x 8	1.5
SDM38MM	38	10 x 8	1.4
SDM40MM	40	12 x 8	1.3
SDM42MM	42	12 x 8	1.2
SDM48MM	48	14 x 7†	1.0
SKM BUSHINGS			
SKMMPB	15	NONE	3.6
SKM19MM	19	6 x 6	3.5
SKM20MM	20	6 x 6	3.5
SKM24MM	24	8 x 7	3.4
SKM28MM	28	8 x 7	3.2
SKM30MM	30	8 x 7	3.2
SKM32MM	32	10 x 8	3.2
SKM35MM	35	10 x 8	1.5
SKM38MM	38	10 x 8	2.9
SKM40MM	40	12 x 8	2.8
SKM42MM	42	12 x 8	2.7
SKM48MM	48	14 x 9	2.4
SKM50MM	50	14 x 9	2.3
SKM55MM	55	16 x 10	2.0
SKM60MM	60	18 x 8†	1.7

Product No.	Bore (mm)	Key	Wt.
SFM BUSHINGS			
SFMMPB	15	NONE	5.1
SFM20MM	20	6 x 6	5.0
SFM24MM	24	8 x 7	4.8
SFM28MM	28	8 x 7	4.7
SFM30MM	30	8 x 7	4.6
SFM35MM	35	10 x 8	4.4
SFM38MM	38	10 x 8	4.2
SFM40MM	40	12 x 8	4.2
SFM42MM	42	12 x 8	4.1
SFM48MM	48	14 x 9	3.7
SFM50MM	50	14 x 9	3.5
SFM55MM	55	16 x 10	3.2
SFM60MM	60	18 x 11	3.0
EM BUSHINGS			
EMMPB	20	NONE	10.8
EM28MM	28	8 x 7	10.6
EM30MM	30	8 x 7	10.5
EM38MM	38	10 x 8	10.0
EM40MM	40	12 x 8	9.9
EM42MM	42	12 x 8	9.8
EM48MM	48	14 x 9	9.3
EM50MM	50	14 x 9	9.2
EM55MM	55	16 x 10	8.6
EM60MM	60	18 x 11	8.1
EM70MM	70	20 x 12	7.1
FM BUSHINGS			
FMMPB	20	NONE	18.0
FM30MM	30	8 x 7	17.6
FM38MM	38	10 x 8	16.9
FM40MM	40	12 x 8	16.8
FM42MM	42	12 x 8	16.7
FM48MM	48	14 x 9	18.0
FM50MM	50	14 x 9	15.7
FM55MM	55	16 x 10	15.0
FM60MM	60	18 x 11	14.3
FM70MM	70	20 x 12	12.9

† SHALLOW KEY FURNISHED

Metric Sure-Grip® L Series Flangeless Bushings

Dimensions

Metric Bushing	Torque Capacity (NM)	Material Type	Max. Bore (Note 1)	DIMENSIONS IN MILLIMETERS		Cap screw Bolt Circle	Screws Required
				B	F		
SKLM	791	D.I.	50	71.4	28.6	60.3	3 - M6
SFLM	1243	D.I.	60	79.4	28.6	69.9	4 - M6
ELM	2260	D.I.	73	97.4	38.1	85.7	4 - M8
FLM	5084	D.I.	80	112.7	60.3	95.3	4 - M10

1. MAX BORE WITH KEYSEAT.

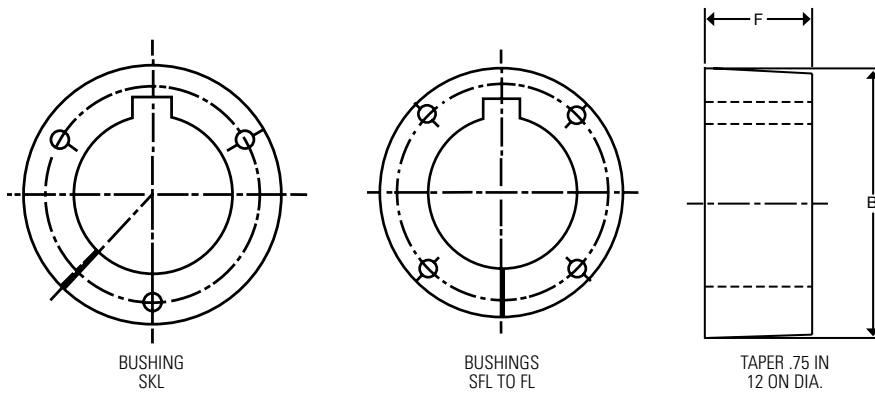

Patent No. 5304101

Product Number	Bore	Key	Weight Lbs.
SKLMMPB	15	None	1.7
SFLMMPB	15	None	2.1
ELMMPB	20	None	4.1
FLMMPB	20	None	8.7

To Install:

IMPORTANT: DO NOT USE LUBRICANTS IN THIS INSTALLATION

- Inspect shafts, bushing, and mating hub. Remove all nicks, paint, dirt, grease, etc. from mating surfaces.
- Place key in shaft's keyseat.
- Slide bushing onto shaft and key. **Small End of Taper Must Be Outboard.**
- Slide tapered mating hub over bushing. Align (1) the shaft key with one of the slots in the mating hub and (2) the drilled holes in mating hub with the threaded holes in the bushing.
- Put lockwashers on cap screws and insert one cap screw thru each drilled hole in the mating hub and into the threaded hole in the bushing.
- Use a Torque Wrench.** Tighten all cap screws evenly and progressively in rotation. Torque around all the cap screws as often as necessary until the listed torque value remains on each cap screw.

To Remove:

- Loosen and remove all cap screws from assembly.
- Install one cap screw in each threaded hole in the mating hub.
- Evenly torque each cap screw in rotation to force the mating hub off the bushing.

Metric Bushing	Screws Required	Newton-Meters (Ft.Lbs.) To Apply With Torque Wrench
SKLM	3 - M6	20 (15)
SFLM	4 - M6	20 (15)
ELM	4 - M8	41 (30)
FLM	4 - M10	75 (55)

CAUTION
The use of lubricants or excessive wrench torques may cause hub stresses high enough to break the mating hub!

Metric Sure-Grip® Bushings



Installation Instructions

The Sure-Grip tapered, QD-type interchangeable bushing offers flexible and easy installation while providing exceptional holding power. To ensure that the bushing performs as specified, it must be installed properly.

Before beginning, make sure the correct size and quantity of parts are available for the installation. The bushing has been manufactured to accept a setscrew over the key and its use is optional. It is packaged with the hardware on sizes QT to J.

To Install:

IMPORTANT:

DO NOT USE LUBRICANTS IN THIS INSTALLATION!

1. Inspect the tapered bore of the sheave and the tapered surface of the bushing. Any paint, dirt, oil, or grease **MUST** be removed.
2. Select the type of mounting (See Fig. 1 or 2) that best suits your application.

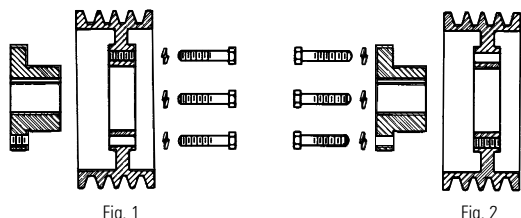

3. **STANDARD MOUNTING:** Install shaft key. (Note: If key was furnished with bushing, you must use that key.) Install bushing on clean shaft, flange end first. If bushing will not freely slide on the shaft, insert a screwdriver or similar object into the flange sawcut to act as a wedge to open the bushing's bore. **Caution: Excessive wedging will split the bushing.** If using the setscrew, tighten it just enough to prevent the bushing from sliding on the shaft. **Caution: Do not over-tighten setscrew!** Slide sheave into position on bushing aligning the drilled holes in the sheave with the tapped holes in the bushing flange. Loosely thread the cap screws with lockwashers into the assembly. **DO NOT USE LUBRICANT ON THE CAP SCREWS!**

4. **REVERSE MOUNTING:** With large end of the taper out, slide sheave onto shaft as far as possible. Install shaft key. (See shaft key note in #3 above.) Install bushing onto shaft so tapered end will mate with sheave. (See wedging note in #3 above.) If using the setscrew, tighten it enough to prevent the bushing from sliding on the shaft. **Caution: Do not over-tighten setscrew!** Pull the sheave up on the bushing, aligning the drilled holes in the bushing flange with the tapped holes in the sheave. Loosely thread the cap screws with lockwashers into the assembly. **DO NOT USE LUBRICANT ON THE CAP SCREWS!**

5. Using a torque wrench, tighten all cap screws evenly and progressively in rotation to the torque value in Table. There must be a gap between the bushing flange and sheave hub when installation is complete. **DO NOT OVER-TORQUE! DO NOT ATTEMPT TO CLOSE GAP BETWEEN BUSHING FLANGE AND SHEAVE HUB!**

To Remove:

1. Relieve drive tension by shortening the center distance between driver and driven sheaves.
2. Lift off belts.
3. Loosen and remove cap screws. If the bushings have keyway setscrews, loosen them.
4. As shown below, insert cap screws (three in JA through J bushings, two in QT bushings) in tapped removal holes and progressively tighten each one until mating part is loose on bushing. (Exception: If mating part is installed with cap screw heads next to motor, with insufficient room to insert screws in tapped holes, loosen cap screws and use wedge between bushing flange and mating part.)
5. Remove mating part from bushing and, if necessary, bushing from shaft.



SCREW TIGHTENING INFORMATION

Tapered Bushing	Size & Thread of Cap Screw	Newton-Meters (Ft.-Lbs.) To Apply With Torque Wrench
QT	M6 x 1.0	12 (9)
JA	M5 x 0.8	7 (5)
SH-SDS-SD	M6 x 1.0	12 (9)
SK	M8 x 1.25	20 (15)
SF	M10 x 1.5	41 (30)
E	M12 x 1.75	81 (60)
F	M16 x 2.0	149 (110)
J	M16 x 2.0	183 (135)

CAUTION: The tightening force on the screws is multiplied many times by the wedging action of the tapered surface. If extreme tightening force is applied, or if a lubricant is used, bursting pressures will be created in the hub of the mating part.