



[www.pintschbubenzler.de](http://www.pintschbubenzler.de)



**Snag Overload Systems.**  
Made in Germany.

## Snag Overload System

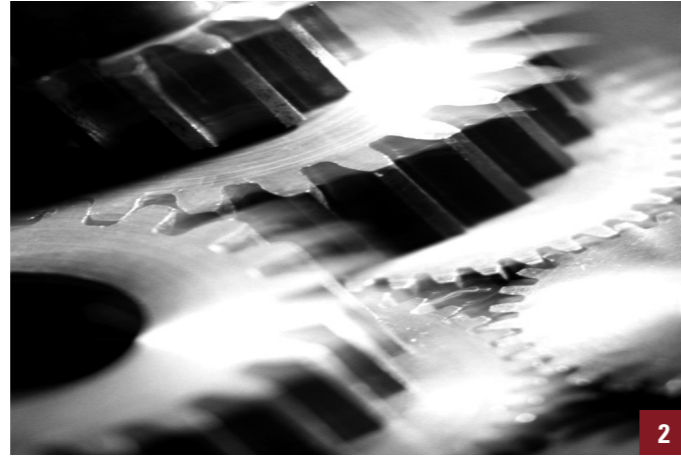

### Definition Snag Load Case

- Sudden stopping of an empty or loaded spreader in a ship cell or other obstacle/barrier during the hoisting procedure of a crane.
- Especially at high speed hoisting a sudden and extreme overload occurs.
- Even a detection with conventional load cells does not provide stopping of the hoist fast enough due to slow PLC delays and motor inertia.

### Consequences

- 1 Broken ropes
- 2 Broken gears
- 3 or even worse

## Snag Overload System



### SOS Principle

1. Motor
2. Malmedie Safety Coupling MSC (see Malmedie catalogue)
3. Malmedie Gear Coupling (see Malmedie catalogue)
4. PINTSCH BUBENZER *LiTec*<sup>®</sup> brake disc
5. PINTSCH BUBENZER thruster disc brake SB28 with VSR unit (see data sheet A04)
6. PINTSCH BUBENZER emergency brake SF with CMB unit – fast setting execution (see data sheet B03)
7. PINTSCH BUBENZER SOS PLC
8. Malmedie Drum Coupling TTX (see Malmedie catalogue)
9. PINTSCH BUBENZER power unit (see data sheet B04)

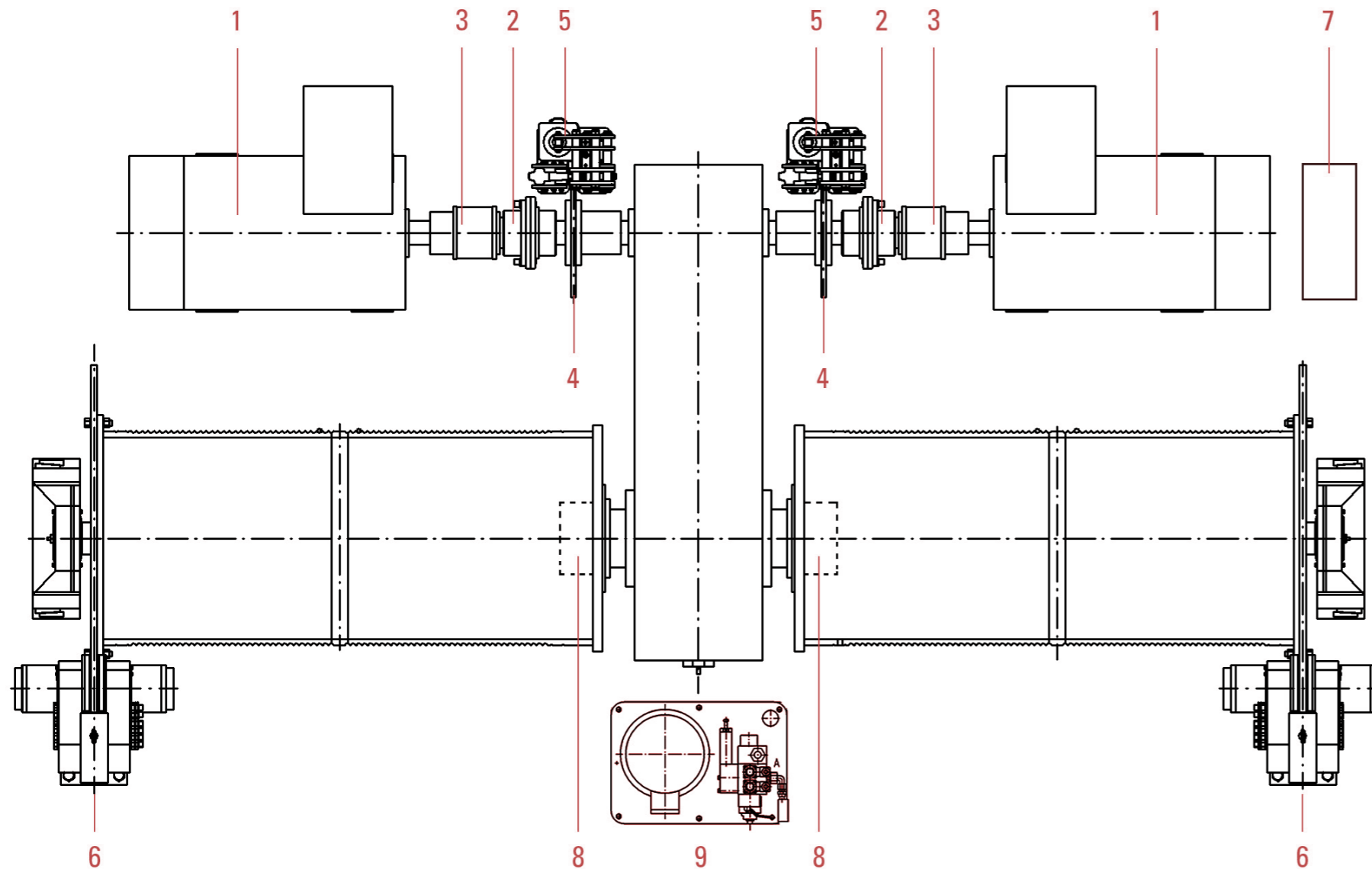
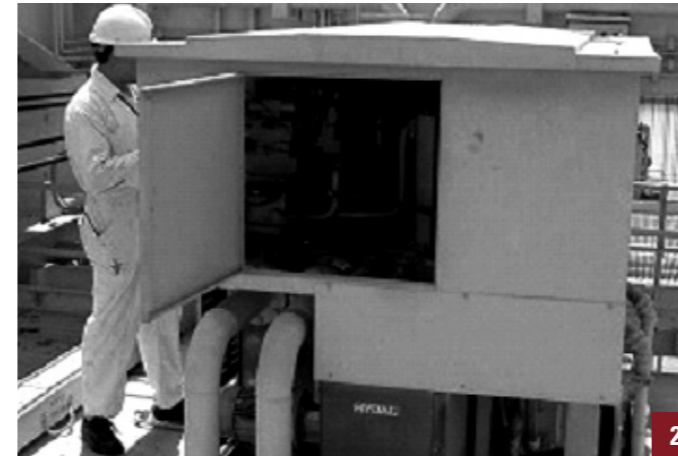

### Conventional Hydraulic System

- A snag load case is detected by electronic load cells.
- A PLC opens a hydraulic valve and large hydraulic cylinders move to give rope until the hoist is stopped.

### Disadvantage

- High maintenance effort (Oil, vents, seals, cylinders etc.)
- High weight and enormous space requirement-machinery on trolley hoists are barely able to provide enough space and load capacity.
- Slow in reaction due to PLC and hydraulic system delay times.
- Rope tension rises significantly before snag load detection is achieved.

### Conventional Hydraulic System

- 1 View cylinders / rope guiding
- 2 Hydraulic Station / Maintenance

### Mechanical SOS (Snag Overload System)

In a Snag Load Case, a Malmedie Safety Coupling MSC instantly separates the motor drives and their high mass inertia from the gearbox. Safety brakes immediately catch the load and avoid a loss of rope. *LiTec*<sup>®</sup> Operating brake discs reduce the drive inertia significantly.

### Advantage

- The MSC reacts mechanically within 5ms in case of a snag load.
- The actual maximum load is far less compared with hydraulic systems.
- The system is installed inside the hoist.
- The total system weight is only 500 kg.
- Maintenance of only 3 hours per year required.
- The system is easily applicable for retrofit.

# Snag Overload System

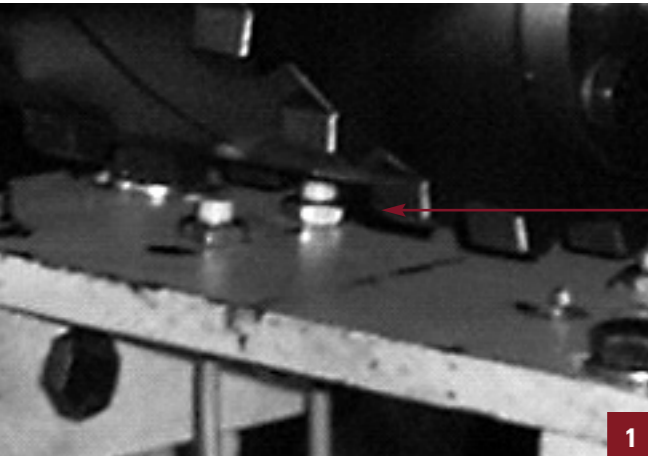

1

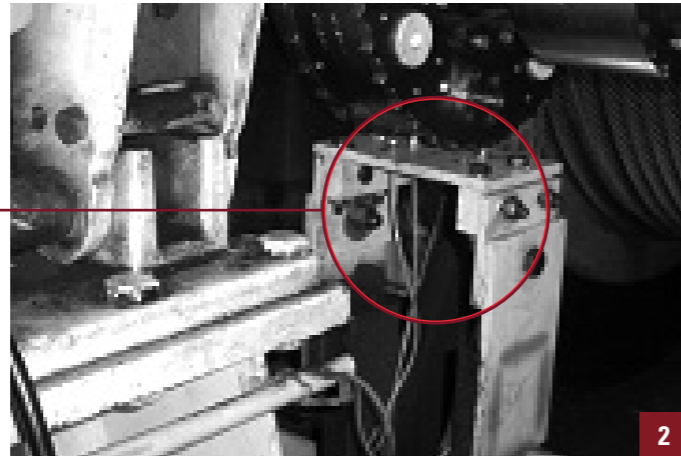

2

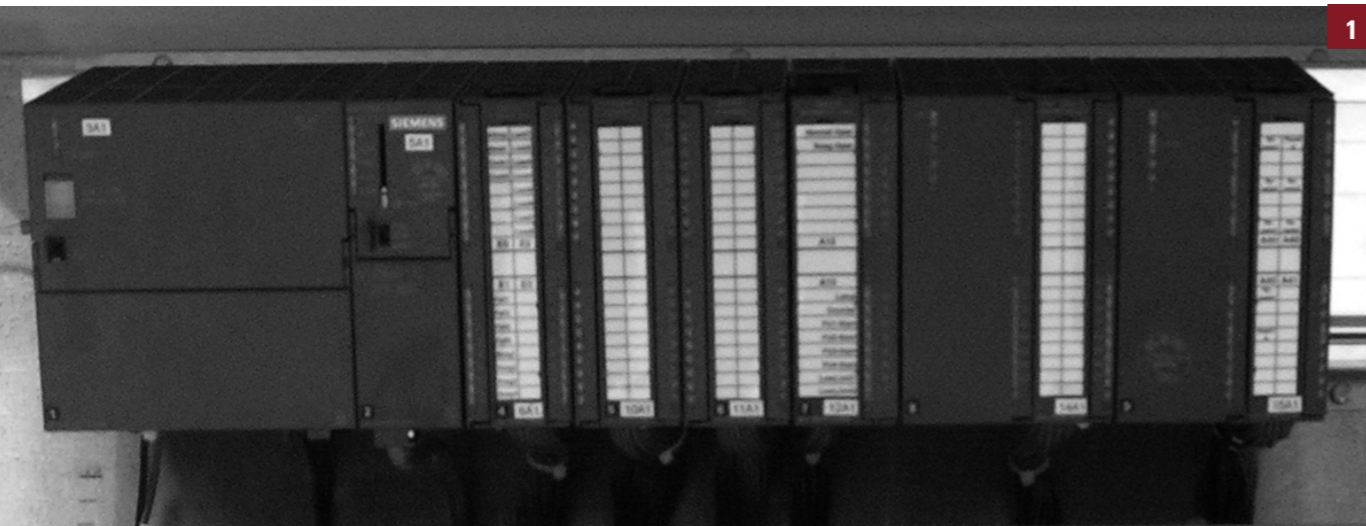

1

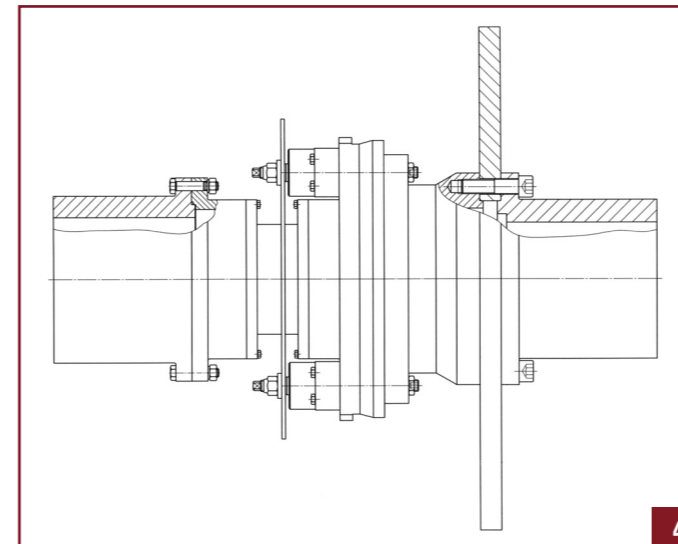
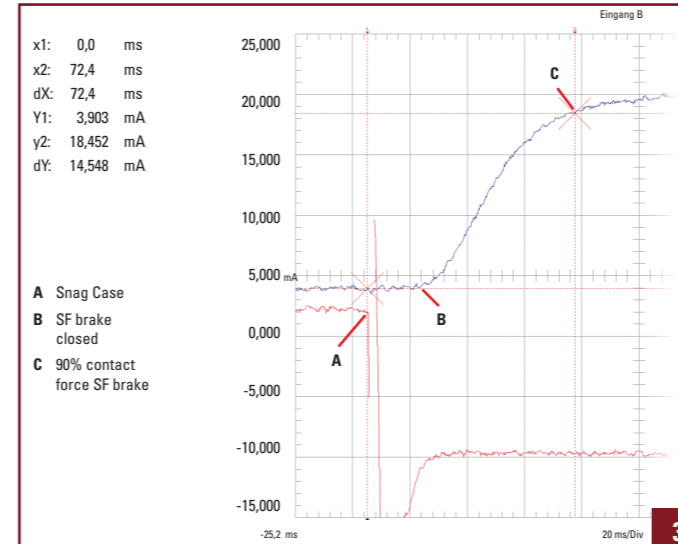

4

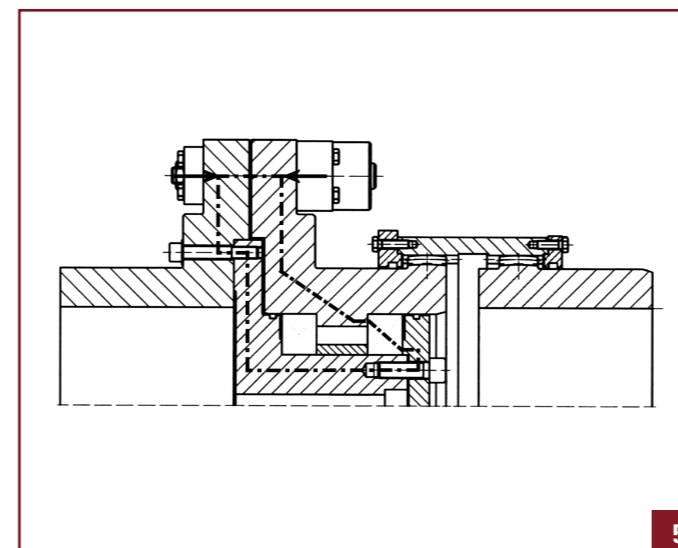

5

## Snag Load Case

- At a Snag Overload, safety elements of the MSC mechanically separate the motors from the drive without exceeding an adjustable maximum torque.
- The remaining inertia of the drive is minimized by using *LiTec*® brake discs.
- Sensors detect the trip of the safety elements and an ultra fast PLC closes the safety brakes.
- When the service brakes are closed, the safety brakes will be opened again. The rope drum is held by the service brakes only.
- The crane operator can now let down the load by using the hoist master switch.

A separate PLC partially opens the service brakes and lets glide the brake disc with controlled rpm.

- Now a brief hoist inspection is obligatory to ensure that no damage has occurred. Then the system is reset manually and the crane can be placed back into service. Inspection and resetting requires only 5-10 minutes.

## Scenario

- 1 SOS PLC
- 2 MSC Coupling with snag & RPM sensors

## MSC

- The safety brakes start to give braking force 30 ms after the MSC trip. 100 ms after the trip the hoist stands still!
- Now the service brakes are activated.

## Scenario

- 3 Contact pressure development after MSC separation
- 4 MSC Coupling
- 5 Load path through MSC Coupling



[www.pintschbubenzler.de](http://www.pintschbubenzler.de)



**PINTSCH BUBENZER GmbH**

Friedrichshüttenstr. 1  
D-57548 Kirchen-Wehbach Telefon  
+49 27 41/94 88-0

Hünxer Str. 149  
D-46537 Dinslaken  
Telefon +49 20 64/602-0

[www.pintschbubenzler.de](http://www.pintschbubenzler.de)