

INSTALLATION AND OPERATING MANUAL

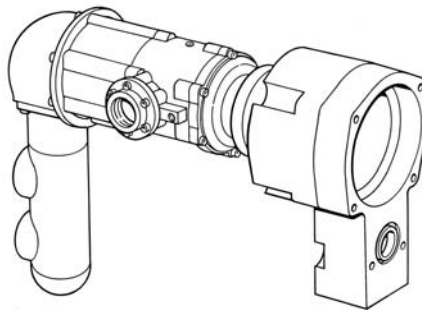

MODEL: T100-CS

P/N: T112-60069-CSL-1-CE

P/N: T115-60069-CSL-1-CE

P/N: T121-60069-CSL-1-CE

TURBOTWIN Engine Air Starter



TABLE OF CONTENTS

Section	Subject	Page
1.0	General Information.....	1
2.0	Starter Installation.....	1
3.0	Supply Line Installation.....	5
4.0	Inlet Pressure Port.....	6
5.0	Exhaust Piping.....	6
6.0	Natural Gas Installation.....	6
7.0	Piping System.....	6
8.0	Starter Operation.....	6

LIST OF TABLES

Table No.	Title	Page
1	T100-C Installation Kit.....	1
2	100-C Tool Kit.....	2

LIST OF FIGURES

Figures	Title	Page
1	Vane Starter Removal.....	2
2	Starter Adapter Removal.....	2
3	Locknut Removal.....	2
4	Drive Gear Removal.....	3
5	Drive Hub Installation.....	3
6	TDI Adapter Installation.....	3
7	Non-engaged Hub Position.....	4
8	Engaged Hub Position.....	4
9	Air Starter Installation.....	4
10	Exhaust Hose Installation.....	5
11	T100-C Envelope Drawing.....	8
12	T100-C Performance Curve (Air).....	9
13	T100-C Performance Curve (Gas).....	9

1.0 GENERAL INFORMATION

The following instructions detail the removal of the two existing vane type starter motors and the installation of the new TDI *TURBOTWIN* air starter. If there are questions not answered in this manual, please contact your TDI distributor or dealer for assistance.

The T100 *TURBOTWIN* starters are designed for operation with compressed air or natural gas; materials used are compatible with “sour” natural gas and marine environments. Small amounts of foreign matter or liquid in the air stream will not adversely affect *TURBOTWIN* starters. As with all other TDI starters, no lubrication is required in the air supply.

Please review the rest of this manual before installing the T100 *TURBOTWIN* series air starter.

WARNINGS, CAUTIONS AND NOTES

Certain types of information are highlighted in this manual for your attention:

WARNING - used where injury to personnel or damage to the equipment is likely.

CAUTION - used where there is the possibility of damage to the equipment.

NOTE - used to point out special interest information.

NOTE

Throughout this manual, the term “air” is used to designate the starter drive medium. Unless otherwise stated, air “” means either compressed air or natural gas.

1.1 PRODUCT IDENTIFICATION

The starter nameplate which is attached to the turbine housing contains the following information: model number, serial number, part number, direction of rotation and the maximum rated operating pressure.

The maximum operating pressure is measured at the check port on the starter inlet with the starter in operation.

CAUTION

Exceeding the maximum pressure shown on the nameplate may result in damage to the starter or damage to the engine.

The housing proof pressure is 600 psig and is also shown on the nameplate. This means the turbine housing will not burst when subjected to a static pressure of 600 psig.

2.0 STARTER INSTALLATION

A turbine air starter does not require lubrication in the supply air. Therefore, if a vane type starter motor is being replaced, TDI recommends that all lubrication devices and lines are removed to minimize flow restrictions.

WARNING

If a fuel (pulse) lubricator has previously been installed in the system, disconnect and plug the line to eliminate spraying diesel fuel on the engine.

WARNING

Do not operate this starter unless it is properly connected to the engine.

CAUTION

Prior to beginning the removal of the existing starter motors, insure the unit is shutdown, post lube has timed off, fuel and start gas are off. Tag out and lock out in full accordance with standard OSHA / Company rules and regulations.

The starter should be installed with the inlet in a position between horizontal and straight down. Any condensation will be restricted to the air lines and not in the starter.

The components listed in the Table 1 (T100C Installation Kit) are required to complete starter installation.

QTY	PART NUMBER	DESCRIPTION
1	2-28673	Gear Adapter
1	2-28674	Tongue Driver
1	2-28676	Exhaust Adapter, Weld
1	9-90001-165	O-ring
1	9-90001-228	O-ring
1	9-90002-041	O-ring
1	9-90211-029	Woodruff Key
1	9-91502-008	Dowel Pin
1	9-92149	Bearing Retainer Nut
1	9-93142	Lock washer
6	14F-25028-012	Screw
4	14F-37516-016	Screw
8	71F-50013-028	Screw
2	9-90001-225	O-ring
2	2-25934-005	Flange, 2" NPT
2	9-93626-017	2" NPT Hex Pipe Nipple
1	2-29760-001	Adapter (1 1/2" to 2" NPT)
2	2-29807-002	Shim (.050 Thick)
2	2-29807-001	Shim (.100 Thick)

Table 1. T100-C Installation Kit (P/N: T100-28675)

TDI TURBOTWIN™

FROM TECH DEVELOPMENT

The tools listed in Table 2 (T100-C Tools Kit) are suggested for use when installing the T100-C air starter, and can be borrowed from TDI to perform starter installation.

The best results can be expected when these tools are used, however the use of other tools is acceptable.

TOOL DESCRIPTION	TDI/PN
3/4" Square Drive Socket	2-28724
Gear Puller Pad	2-28722
Gear Puller	2-28720
Torque Wrench	2-28719
Anti-rotation Tool	2-28716
Locknut Socket	2-28718

Table 2. T100-C Tools Kit (P/N: T100-28721)

2.1 VANE STARTER REMOVAL

Remove the split flange clamps from the inlet and exhaust hoses on the starter end of the hoses. Retain the bolts and clamps to be used later. Discard the o-rings.

Remove one inlet flange fitting and both exhaust flange fittings from the vane starters. Retain these for later use.

Remove the eight mounting nuts from each vane starter motor mount flange and retain these for later reuse.

Remove and discard both the vane starter motors.

Remove the split flange clamps from the oil drain on the bottom starter adapter. Retain the bolts and clamps for later reuse.

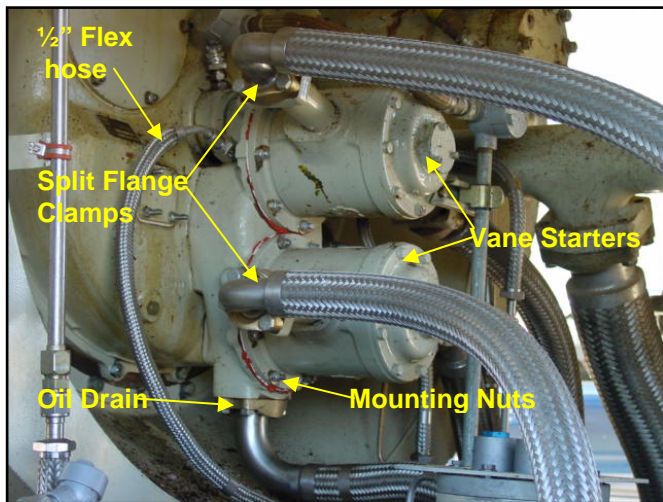

Figure 1. Vane Starter Removal

Remove the 1/2" metal flex hose from the starter gear lubrication jet and disconnect the hose at its origin on the

main oil line. Since this hose is no longer required install a pressure cap at the main oil line fitting.

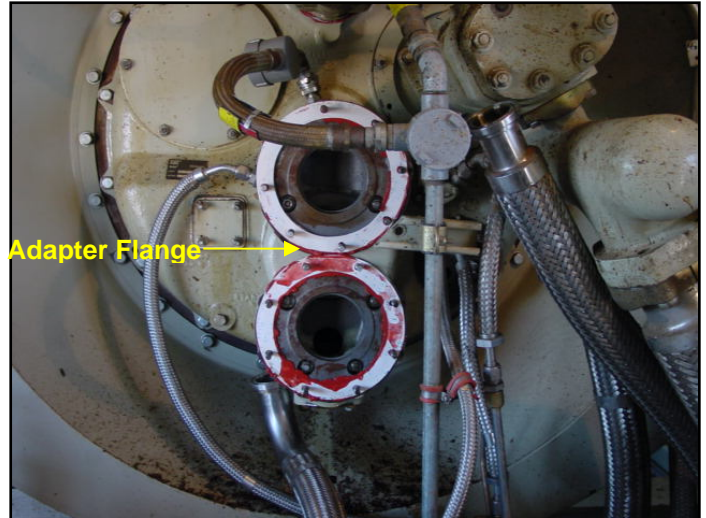

Figure 2. Starter Adapter Removal

Remove the six starter adapter retaining nuts and washers. Retain these for later reuse. Remove the starter adapter by gently prying behind the adapter. Slide the starter adapter off the studs and discard the adapter.

Remove the o-ring from the adapter mounting pilot ring.

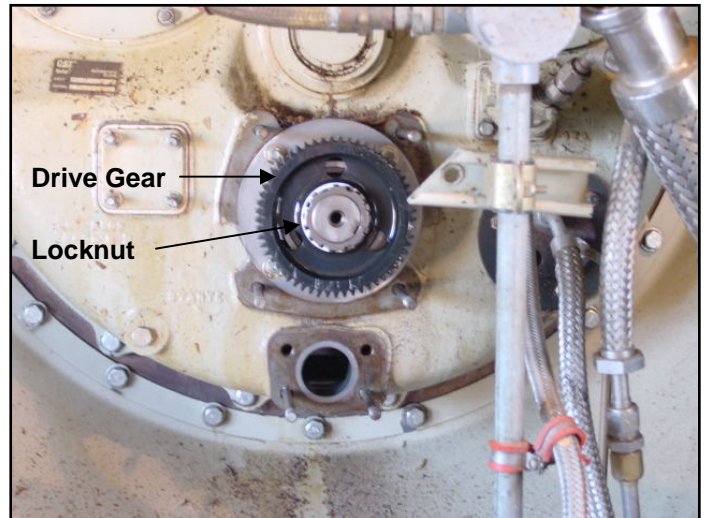
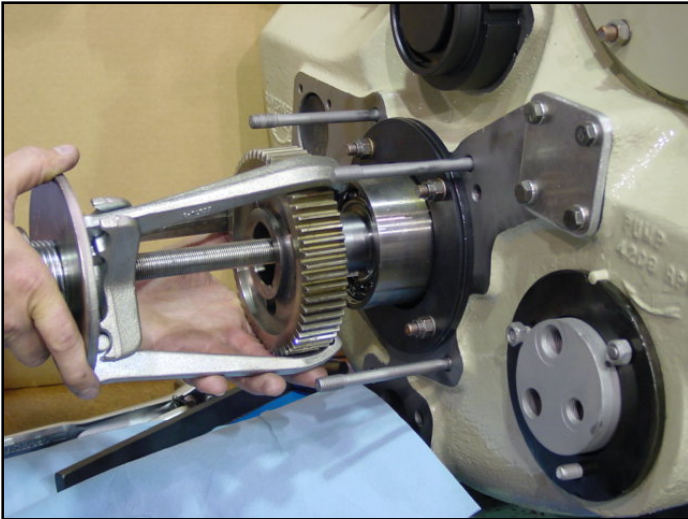

Figure 3. Locknut removal

Use a small punch or similar tool de-stake the lock washer on the starter drive gear.

Using the holding tool, special socket and 1/2" break over bar loosen the drive gear locknut. Remove and discard the locknut & washer.

Install the puller center guide bolt in the threaded hole of the drive gear shaft. Install the puller and remove the



drive gear as shown in figure 4.

Figure 4. Drive Gear Removal

Remove the existing drive key from the gear shaft. Install the new high strength key provided with the kit.

2.2 T100-C AIR STARTER INSTALLATION

NOTE

All bolts should be lubricated with anti-seize compound prior to use. All torque specifications contained herein are for lubricated threads.

Install the new drive hub supplied with the kit until it is completely seated on the shaft shoulder. Insure the key and hub slot are aligned.

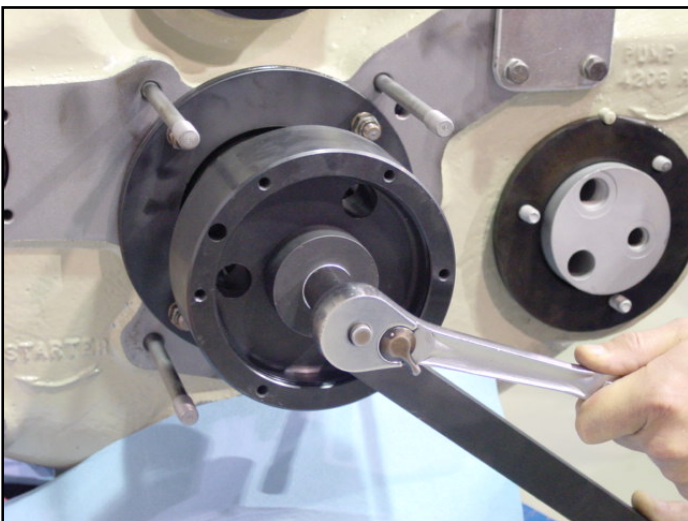

Figure 5. Drive Hub Installation

Install the new lock washer and locknut supplied with the kit. Using the holding tool, special socket and a torque wrench tighten the nut and torque to 165-175 ft. lbs. (224-237 Nm). Use caution to align one nut slot with a lock tab on the washer. Bend the lock tab over and insure it is locked in the nut.

Place the 3/8" dowel pin supplied with the kit in the hub piece. Place the hub cover in place on the hub and install six allen head screws finger tight. Use a soft hammer and tap the hub cover in place while pressing the dowel pin in the cover. Torque the allen head screws to 180 in. lbs. (20.4 Nm).

Remove the TDI starter from the adapter provided in the kit. Retain the bolts for later reuse.

Install a new o-ring on the adapter mounting pilot ring on the accessory drive. Install a new o-ring on the oil drain port of the new TDI adapter.

Slide the new TDI adapter on the mounting studs. Use caution to insure the adapter is installed flat to avoid o-ring damage. Install the washers and nuts retained at removal. Alternately tighten the nuts to guide the adapter on to the mounting pilot ring.

Torque the nuts to 125 ft. lbs. (170 Nm)

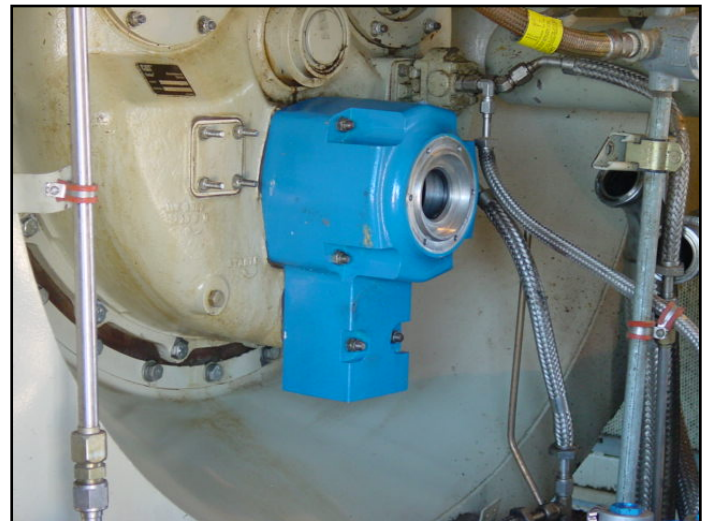

Figure 6. TDI Adapter Installation

WARNING

Add 150 ML of synthetic oil (recommended MIL 7808H) to starter gearbox prior to starter operation. Do not operate the starter unless the gearbox is filled to the proper oil level and maintained at this level.

TDI TURBOTWIN™

FROM TECH DEVELOPMENT

Install the T100-C air starter. Use caution to align the "drive blade" with the slot in the drive hub cover.

If maximum drive blade engagement into drive hub slot is not achieved when starter is installed (figure 7), the shims provided with the starter can be repositioned as shown in figure 8 to move the drive hub forward into engagement.

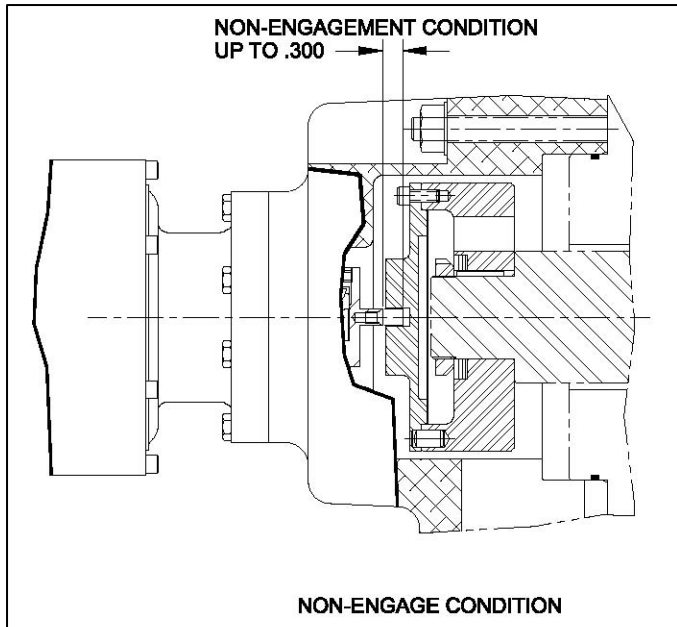

Figure 7. Non-engaged hub position

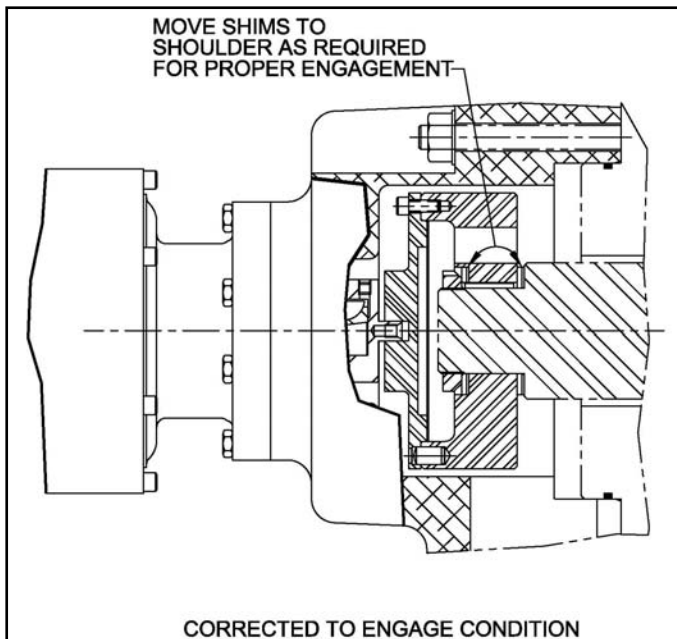

Figure 8. Drive Hub in the Engaged Position

Insure the 2" inlet port is in the left horizontal position. Install the bolts retained at removal and tighten to 190 in. lbs. (21.5 Nm)

NOTE

Use of a pipe thread sealer or Teflon tape is recommended for the installation of all pipe thread fittings in the following steps.

Install a 1½" X 2" bushing reducer when required. Install the 1½" or 2" split flange inlet adapter retained from the vane motor at removal.

Place a new o-ring on the exhaust manifold flange. Install the exhaust manifold pointed down on the TDI starter with the threaded ports facing to the right. Torque the 3/8" Allen screws to 170 in. lbs. (19.26 Nm).

Install the split flange exhaust adapters, retained from the vane motor at removal in the exhaust manifold of the TDI starter.

NOTE

Only one of the two 1½" inlet hoses will be required for the TDI starter. Select the one most suited to the fit of your new starter system at this time. Disconnect the unused hose and discard.

CAUTION

Use caution when installing metal flex hoses to avoid any unnecessary twisting or rub from adjacent hoses, brackets, or hardware.

Install the inlet hose, and a new o-ring supplied with the kit, on the starter split flange adapter using the bolts and clamps retained at removal.



Figure 9. Air Starter Installation

Disconnect the opposite end of the inlet hose from the oil lubricator and retain the bolts and clamps for later reuse.

Remove the bolts split flange clamps retaining both lubricators and remove the lubricators.

NOTE

Oil lubricators are not required for TDI starters. However, one set of inlet and outlet fittings will be required. Remove one set of fittings and discard both lubricators.

Install one set of lubricator fittings into the 1½" pipe collar provided in the kit, and reinstall in one of the previous lubricator locations using a new o-ring. Install the split flange blank cover and new o-ring, provided in the kit, on the remaining unused lubricator location.

Reinstall the hose end removed earlier with a new o-ring provided.

Install both exhaust split flange adapters in the exhaust manifold. Install both exhaust hoses using new o-rings provided.



Figure 10. Exhaust Hose Installation

After completion of the installation remove all lock out and tag out protection in accordance with OSHA / Company rules and regulations.

During the first start cycle observe operation and soap check for leaks at all fittings and hoses that were disturbed during the installation. Repeat this step if required - no leaks permitted.

3.0 SUPPLY LINE INSTALLATION

WARNING

Be sure to either bleed the pressurized air reservoir and/or safety the system such as closing all valves prior to installing starter supply line.

Care must be taken to ensure that all inlet supply line piping is no less than 1.5" and all components used are capable of passing the required air flow.

NOTE

Valves with a Cv of 40 or higher are recommended.

If the supply line must be longer than 20 feet, the inlet supply line piping should be increased to 2" in diameter to ensure proper performance by your **TURBOTWIN**.

Because turbine starters such as the **T100 TURBOTWIN series** are sensitive to flow restrictions, care must be taken to use uniform hose or tubing and fittings for connection of the supply line. Tees, elbows and line length must be kept to a minimum. TDI recommends that hose or flex couplings are installed to eliminate possible leakage caused by strain on the supply line.

Normally, an air strainer is not required. However, in dirty environments use of a #40 mesh Y-strainer is recommended. The **T100 TURBOTWIN series** is highly tolerant of dirt in the air line, however, starter life can be increased with the use of an air strainer.

A pressure regulator is required when the air supply pressure is great enough to exceed the starter operating pressure (at the inlet port) and/or the maximum torque.

The supply line should be dry-fitted for proper alignment /location prior to final assembly. All pipe threaded joints should be sealed with Loctite Pipe Thread Sealant (TDI P/N 9-94085) or equivalent for leak tight joints prior to final assembly. Be sure to tighten all joints to proper torque after final assembly.

CAUTION

In cold weather climates, care should be taken while designing your installation to prevent condensation from developing in the starter system. In systems with a regulator valve or relay valve, there is the possibility of freeze-ups.

A tee connection with a quick disconnect can be added to the inlet. This will allow an external air source to be used to accomplish a "blow start" if the system freezes. Once the engine has been started, the other system components may be thawed.

CAUTION

On new installations, it is strongly recommended to blow out the supply line with air to remove possible dirt and welding slag prior to final connection to the *TURBOTWIN* starter. Be sure to secure the free end of the supply line prior to blowing out the line.

4.0 INLET PRESSURE PORT

A 1/4" NPT port is located on the air inlet. This port may be used to check the supply pressure at the starter when the starter is operating. Remove the 1/4" NPT pipe plug and save for later use. Install a 1/4" minimum size tubing to the port. Route the tubing away from the starter to a safe location away from the engine. Install a pressure gauge on the tubing. This pressure monitoring line/gauge may be permanently installed. Use Loctite Pipe Thread Sealant or equivalent. Alternately, a pressure transducer may be installed at the pressure check port and electrical lines routed to a digital display at the operator's station. This pressure port is invaluable in diagnosing air starter and/or installation problems.

5.0 EXHAUST PIPING

The turbine exhaust may be plumbed away from the starter area. All starters using natural gas must be piped according to industry codes and local regulations.

The performance of a turbine starter will be decreased because of back pressure when smaller than recommended exhaust piping is installed. If back pressure hampers starter performance, compensation can be made by increasing the supply pressure. Consult your TDI distributor for advice.

Exhaust piping should be routed downward to help prevent any accumulation of condensation in the starter motor.

If the overhung section of the starter is not otherwise supported, TDI recommends supporting the exhaust piping with a suitable bracket(s).

6.0 NATURAL GAS INSTALLATION

The installation of the starter using natural gas is similar to the air installation except all fittings, piping, valves and regulators must be compatible with natural gas.

Proper control of natural gas is a major consideration when used in the starter system. All starters using natural gas must pipe the exhaust according to industry codes and local regulations.

There is a natural gas vent port in the turbine housing that is plugged for compressed air use. This vent is used to remove any natural gas that could leak past the primary turbine shaft seal. Remove this 3/8"NPT plug and install a line to carry gas away from the starter area.

WARNING

Do not connect the turbine housing vent line to the turbine exhaust line. Exhaust gas can pressurize the housing.

7.0 PIPING SYSTEM

Only type approved metallic hose assemblies are approved in permanently pressurized compressed air lines of starters. Non-metallic hose assemblies are allowed only in cases where the piping system will be emptied after the starting procedure.

Pipe unions must be type approved by GL. Downstream of the pressure regulator a pressure relief valve is to be provided.

8.0 STARTER OPERATION

Prior to operation, check that all connections are tight and free from leaks. Check the 1/4" NPT pipe plug or a pressure gauge/transducer that may be connected to the pressure port on the starter inlet.

WARNING

Do not operate the TDI *TURBOTWIN* starter with air pressure greater than the pressure rating on the nameplate. This pressure is measured at the starter inlet while the starter is running.

The maximum operating pressure limit is the inlet pressure measured at the starter's inlet pressure check port. In order to check the starter, a 1/4"NPT pipe tap connection is provided in the inlet housing to attach a pressure gauge/transducer). The maximum pressure assumes an open exhaust (standard turbine exhaust guard). The standard exhaust guard causes no back pressure.

The static non-flowing supply pressure will always be higher than the operating (dynamic) pressure. The maximum pressure limit (proof pressure) that the TDI *TURBOTWIN* starter housings may be subjected to is 600 PSIG (42 BAR). System pressure that exceeds the

maximum operating limit must use a pressure reducing device to ensure that the operating pressure limit to the TDI *TURBOTWIN* starter is maintained.

System static pressure that exceeds the 600 PSIG (42 BAR) limit must, in addition to pressure reducer devices, incorporate a pressure relief valve set below 600 PSIG (42 BAR) in the supply air line.

All appropriate local pressure codes and pressure limitations on other system components must be adhered to and supersede the guidelines given in this manual.

Consult your TDI distributor if you have exhaust plumbing that creates back pressure and reduces starter performance. You may be able to increase the supply pressure to restore the lost power.

Follow the engine manufacturer's instructions for starting the engine.

TDI TURBOTWIN™

FROM TECH DEVELOPMENT

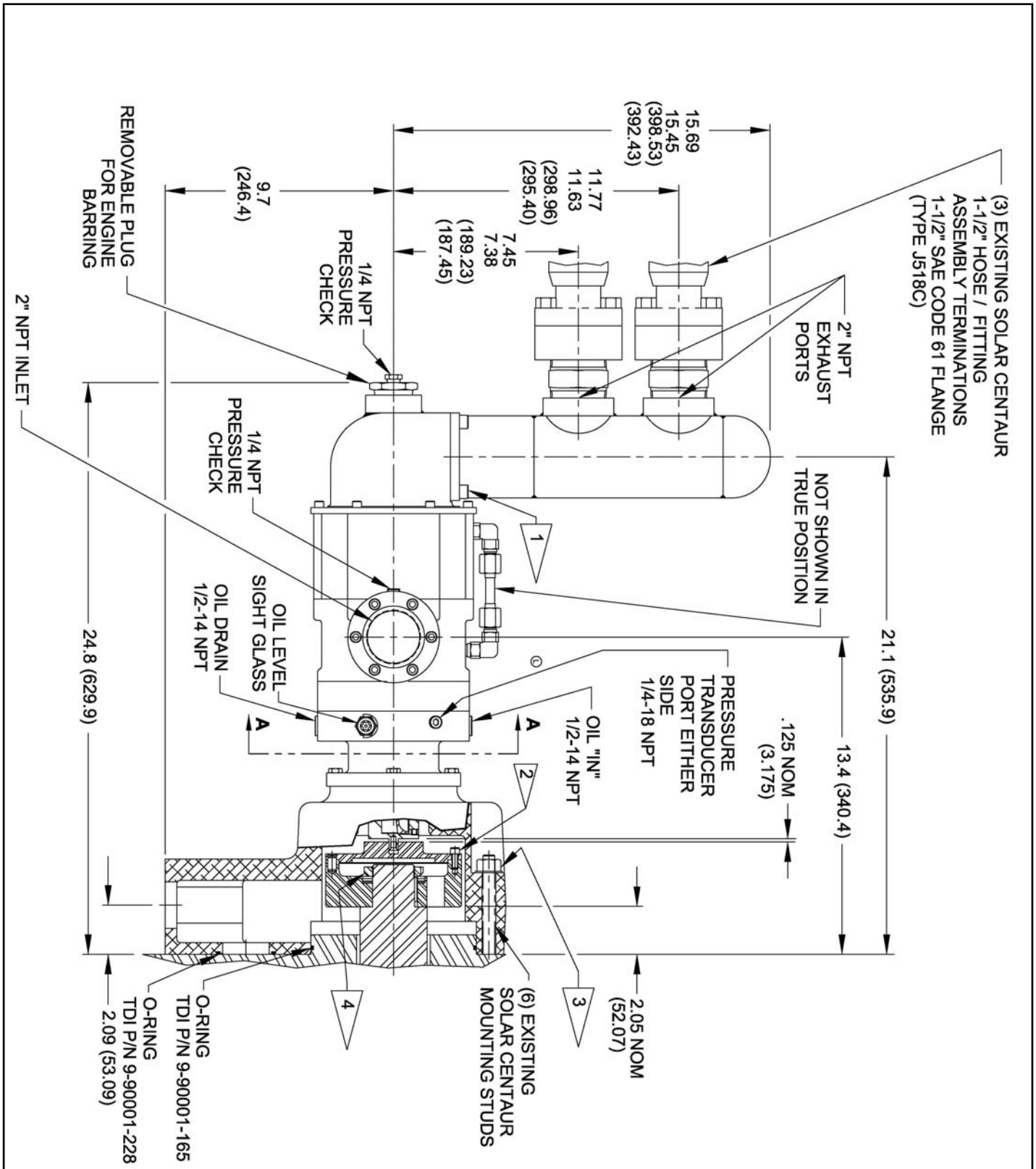

Figure 11. T100-CS Envelope Drawing

T100C Performance Curves

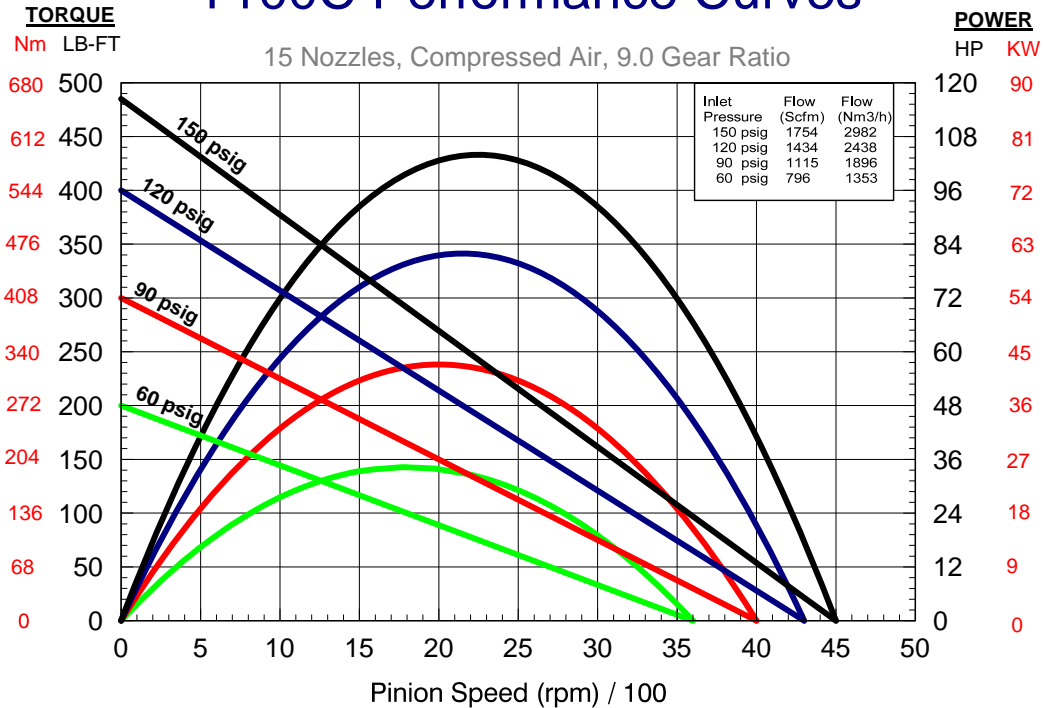

Figure 12. T100-C Performance Curve (Compressed Air)

T100C Performance Curves

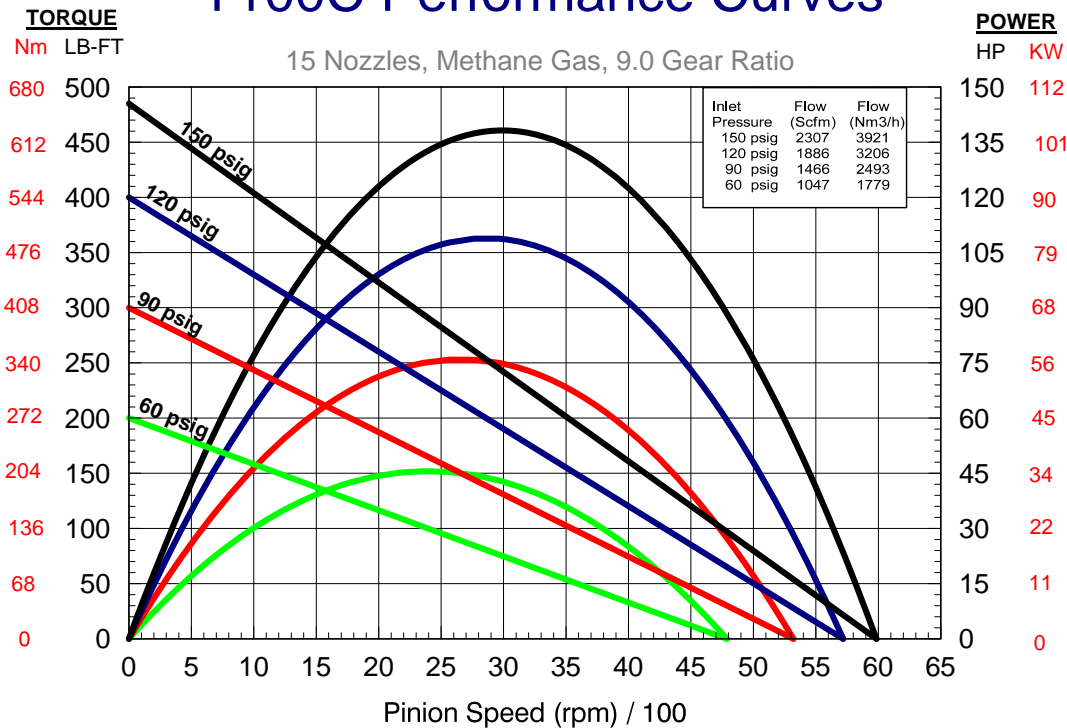

Figure 13. T100-C Performance Curve (Methane Gas)