

# INSTALLATION AND OPERATING MANUAL

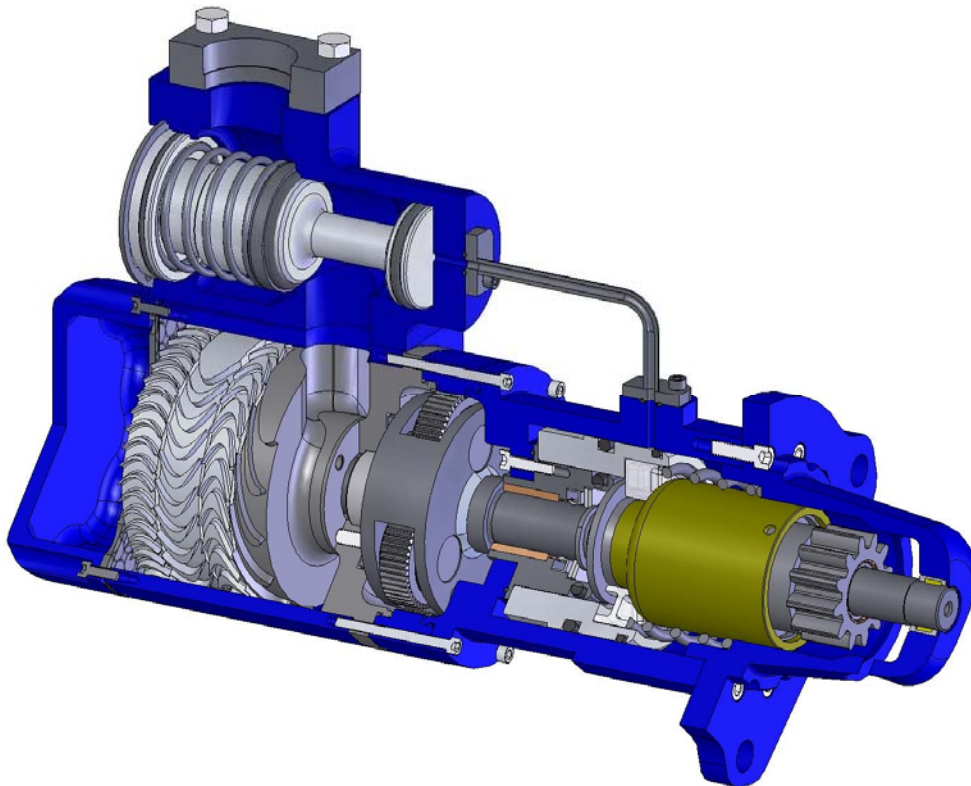

## MODEL: T25 **TURBOTWIN** Engine Air Starter

## TABLE OF CONTENTS

SECTION	SUBJECT	PAGE
1.0	General Information.....	1
1.1	Warnings, Cautions, & Notes.....	1
1.2	Installation and Service.....	1
1.3	Product Identification.....	1
2.0	Orientation of the Starter.....	2
2.1	Model T25 Orientation.....	2
2.1.1	Starter Mounting Flange Orientation.....	2
2.1.2	Exhaust Housing Orientation.....	2
2.2	Supply and Exhaust Installation.....	2
3.0	Installing the Starter.....	2
3.1	Best Installation Practices.....	3
4.0	Starter Operation.....	4
4.1	Best Operating Practices.....	5
5.0	<i>TURBOTWIN</i> Warranty.....	5
6.0	Operator's Troubleshooting Guide.....	6
FIGURES	ILLUSTRATIONS	PAGE
1	T25 Envelope Drawing.....	7
2	T25 Installation Diagram.....	8
	T25 Performance Curve - 6 nozzles (air).....	9
	T25 Performance Curve - 12 nozzle (air).....	9

## 1.0 GENERAL INFORMATION

This manual provides instructions for the installation and operation of the TDI TurboTwin™ Model T25 engine air starter. If there are questions not answered by this manual, please contact your TDI TurboTwin™ distributor or dealer for assistance.

The Model T25 is a turbine driven air starter with a pre-engage starter drive. It is well suited for starting diesel engines up to 15 liters. The Model T25 is designed for installation on engines using a SAE 1, 2, or 3 mounting pad.

The T25 Series starters are suited to operate within a wide range of inlet air pressures and ambient temperatures. The engine size and parasitic loading will determine the exact minimum pressure that will insure reliable starting.

The T25 Series starters are designed for operation with compressed air only. Moderate amounts of foreign matter or liquid in the air stream will not adversely affect T25 Series starters. The T25 does not require lubrication in the supply air.

You need to review the rest of this manual before installing your TDI TurboTwin™ T25 Series starter.

### 1.1 WARNINGS, CAUTIONS, & NOTES

Throughout this manual, certain types of information will be highlighted for your attention:

**WARNING** - used where injury to personnel or damage to the equipment is possible.

**CAUTION** - used where there is the possibility of damage to the equipment.

**NOTE** - used to point out special interest information.

### 1.2 INSTALLATION and SERVICE

The TDI TurboTwin™ T25 Series starters provide distinct advantages of size and efficiency compared to electric motor, vane-type, or other turbine-type air starters. It is important to properly install the starter to receive full benefit of these advantages. Repair technicians or service organizations without turbine

starter experience should not attempt to repair this starter until they receive factory approved training from TDI, or its representatives. Proper operation and repair of your TDI TurboTwin™ T25 Series starter will assure continued reliable and superior performance for many years.

#### **WARNING**

The TDI TurboTwin™ T25 Series starter must be installed and operated in accordance with the instructions given in this manual. Failure to properly install the starter or failure to operate it according to these instructions may result in damage to the starter or the engine, or cause personal injury.

#### **NOTE**

THIS STARTER IS TO BE SERVICED ONLY BY AUTHORIZED TDI TURBOTWIN™ DISTRIBUTORS, DEALERS, AND REPAIR STATIONS. DO NOT OPERATE THIS STARTER UNLESS IT IS PROPERLY ATTACHED TO AN ENGINE.

### 1.3 PRODUCT IDENTIFICATION

The identification nameplate attached to starter housing should indicate the following information:

- Model Designation - T25
- Part Number identifies number of nozzles, orientation, and pinion configuration.
- Serial Number (date manufactured code)
- Maximum Operating (Inlet) Supply Pressure
- Direction of Rotation

#### **NOTE**

Direction of Rotation - either left hand LH (CCW) or right hand RH (CW) is designated from pinion end of the starter.

#### **NOTE**

Maximum Operating Pressure as indicated on the nameplate can be verified at the pressure check port below starter inlet port, and set dynamically.

#### **NOTE**

The Proof Pressure shown on the nameplate indicates the maximum static pressure rating at which starter turbine housing will not burst in operation.

## 2.0 ORIENTATION OF THE STARTER

If the factory orientation of the starter's pinion housing, gearbox assembly, or optional exhaust port does not fit your engine installation, these components can be re-oriented.

### 2.1 MODEL T25 ORIENTATION

- Determine the required orientation of the mounting flange relative to the desired position of starter inlet. The optional exhaust adapter can also orient to the desired position.
- Note that the drive housing can be rotated to twelve different positions relative to the gearbox housing. Additionally, the optional exhaust port can be rotated to eight positions relative to the inlet port.

#### CAUTION

All screw threads are treated at the factory with a fastener retention compound. Every screw and tapped hole must be clean and have Loctite 242 applied to the threads before being reinstalled.

#### 2.1.1 Drive Housing Re-Orientation

Remove the 12 drive housing to gearbox housing screws and rotate drive housing to desired position.

Reinstall the twelve socket head cap screws and torque to 150 in-lbs.

#### 2.1.2 Exhaust Housing Orientation

The T25 is configured with an exhaust deflector. Remove the 8 screws connecting the exhaust to the turbine assembly. Rotate the exhaust deflector to the desired position relative to the inlet port.

Apply Loctite 242 to the screw threads and reinstall the 8 screws. Torque to 59 in-lbs.

## 2.2 SUPPLY & EXHAUST INSTALLATION

#### WARNING

Be sure to either bleed the pressurized air reservoir and/or safety the system such as closing all air supply valves prior to installing starter or a new supply line.

The T25 supply line consists of the line from the air supply source (via a pressure regulator when necessary) through filters, manual and/or automatic relay valves to the starter inlet.

Hard piping may be used on supply lines. A section of flexible tubing is recommended between starter inlet to the hard piping. This can prevent leaks due to piping weight & vibration and offers ease of field maintenance/replacement of the starter.

## 3.0 INSTALLING THE STARTER

The components may vary in shape, but there must be at least a start switch and air source to operate a T25 starter. A regulator should be installed in the starting system if the air pressure exceeds the maximum pressure rating of the starter. The regulator should be installed within 10 feet (3 meters) of the starter.

A turbine driven starter does not require lubrication in the supply air. Therefore, if a vane-type starter motor is replaced, TDI recommends all lubrication devices and lines are removed to minimize flow restrictions.

#### WARNING

If a fuel (pulse) lubricator has previously been installed in the system, disconnect and plug the line to eliminate spraying diesel fuel on the engine.

Liberally grease the starter's pinion teeth with chassis lube and then install the T25 Series starter on the engine. Tighten all mounting hardware as appropriate.

After securing the starter to the engine, attach the supply air line to the "IN" port of the integral relay valve. Connect the wires from the start switch to the solenoid on the relay valve.

Because turbine starters are sensitive to flow restrictions, care must be taken to use uniform hose or tubing and fittings for supply air line connection. Tees, elbows, and line length must be kept to a minimum. TDI recommends hose or flex couplings

are installed to eliminate possible leakage caused by strain on the supply air line or engine vibration.

Normally a filter is not required in the supply line. However, in dirty environments, use of a #40 mesh Y-strainer P/N: 52-93550-100 is recommended.

Only type approved metallic hose assemblies are allowed in permanently pressurized compressed air lines of starters. Non-metallic hose assemblies are allowed only if the piping system will be emptied after the starting procedure.

Pipe unions must be type approved by GL. Downstream of the pressure regulator a pressure relief valve is to be provided.

### **WARNING**

Recheck all connections for tight fit to eliminate air leakage.



T25 installed on MAN D2842 engine

### **3.1 BEST INSTALLATION PRACTICES**

- Wear protective gloves and steel toe shoes when installing air starter.
- Follow engine manufacturer's torque requirements for all starter attachment screws.
- For new installations or where new piping or receiver tanks are installed, always purge the starter supply line of debris before installing or operating the air starter.
- Install and maintain a 40-mesh (400 micron) Y-strainer in the starter supply line to reduce the level of contamination entering air starter.

- To insure maximum performance and starter life, use the recommended starter inlet and exhaust piping sizes.
- Limit the number of elbows installed in starting system supply/exhaust lines and minimize to the extent possible, the length of these lines to prevent excessive flow losses and/or back pressure.
- Use a quick-opening starter relay valve to operate air starter, and install within 10 feet of the air starter inlet.
- To properly control the starter, use a control valve configured with 3 ports (IN, OUT, VENT). Use a 3-way valve only. Never use a 2-way or manual ball valve to operate a pre-engaged starter model or within the pre-engagement controls piping.)
- When a pressure regulator is required, locate this at a minimum distance of 10 feet away from the starter relay valve.
- Utilize pressure regulator(s) with flow characteristics that meet or exceed the selected air starter's flow requirements (Cu factor).
- Regulators located far from the starter may require sensing downstream pressure closer

to the starter inlet to deliver the desired dynamic pressure to the starter while operating.

- Do not use any mist or injection type lubricators/devices in supply line to a TDI air starter.
- Where used in sub-freezing ambient temperatures, install air starter with inlet and exhaust in 6 o'clock position to allow drainage preventing freezing of trapped moisture in the starter inlet.

## 4.0 STARTER OPERATION

The maximum operating pressure limit is that pressure measured at the starter inlet pressure check port during the crank cycle. In order to check the starter inlet pressure, an 1/8" NPT pipe tap connection is provided in the inlet housing for attaching a pressure gauge.

### CAUTION

IN NO CASE SHOULD INLET OPERATING PRESSURE EXCEED 10.3 BAR (150 PSIG).

### WARNING

Do not operate the T25 Series air starter with air pressure greater than the pressure rating on the nameplate. This pressure should be measured at the starter inlet while the starter is operating.

The static supply pressure will always be higher than the operating pressure. As a guideline, the maximum pressure limit (proof pressure) the T25 Series starter may be subjected to is 600 psig (42 bar). System pressure that exceeds the maximum operating limit must use a pressure regulator to insure operating pressure limit to the T25 Series starter is maintained.

System pressure that exceeds the 600 PSIG (42 bar) limit must, in addition to a pressure reducer device, incorporate a pressure relief valve, set below 600 PSIG (42 bar), in the supply air line. The relief valve can be set 10 - 15% above the starter's maximum pressure rating.

### WARNING

All appropriate local pressure codes and pressure limitations on other system components must be adhered to and supersedes guidelines given in this manual.

Follow all the engine manufacturer's instructions for starting the engine.

### WARNING

Do not engage the starter while the engine is running.

If the starter fails to function properly when first operated, or its performance deteriorates with use, refer to the Operator's Trouble Shooting Guide, Section 6.0. If you cannot solve the problem, or

repair is necessary, contact your local TDI TurboTwin™ distributor or dealer.

Turbine starters share a common characteristic known as "coast-down". Once unloaded, turbines coast to a stop from their unloaded or *free-speed*. Turbines behave differently in this respect, compared to positive displacement devices, because the friction (drag) of rubbing, sealing surfaces (piston rings or vanes) quickly stops an unloaded machine. Less encumbered by drag, and typically decelerating from much higher operating speeds, turbines can take considerably longer to come to rest.

When pre-engaged starters are used, a procedure specifying a 30-second delay between engine crank attempts is sufficient to insure correct operation. This is common practice by many users and delays

are typically programmed into fully automated starter control systems.

This "**30 Second Rule**" should also be strictly followed when using the starter in a "manual mode" or to perform routine maintenance tasks such as engine timing, inspections, valve adjustments, etc.

### WARNING

Re-engaging pre-engaged turbine starters during coast-down can damage the starter pinion and the engine ring gear. Turbine air starters must **NEVER** be re-engaged before the starter comes to a complete stop.

To ensure correct starter operation, users may choose to incorporate an electronic P/N: 2-28582 or pneumatic control device to prevent accidental re-engagement during coast-down. In addition, operators and technicians should be educated about the effects of coast-down.

### CAUTION

The grease used in the planetary system has a shelf life of 2 years. Therefore, if the starter is NOT installed and operated on the engine for 2 years after the starter is manufactured, the grease should be replaced prior to starter operation. The manufactured date is reflected in the starter serial number. (Ex: S/N: 0802-0567 has a manufactured date of February 2008).



#### 4.1 BEST OPERATING PRACTICES

- To extend starter life, apply only the minimum pressure required, to successfully crank & start the engine.
- Never exceed starter maximum operating pressure identified on starter nameplate. This pressure can be best measured dynamically while starter is running.
- For longer starter life, operate (or design controls) to shut off supply pressure to the air starter immediately after a successful engine start.
- If engine fails to start or stalls, wait at least 15 seconds before attempting to re-start to allow the starter to coast to a complete stop.
- Never re-engage pinion into ring gear when starter is coasting down as this may damage the starter pinion gear and engine ring gear.
- Never engage starter while engine is operating as this may damage the starter, the pinion gear, and engine ring gear

#### 5.0 WARRANTY

Tech Development (TDI) warrants to the original user of the TDI *TURBOTWIN™* air starters to be free from defects in material and workmanship for a period of one year from the date of installation. The warranty period shall not extend beyond two years from the date the unit was manufactured. (i.e.: a unit with a manufactured date of July 1999 (SN: 9907-101) will not be covered under warranty after July 2001). The conditions of this warranty are: **a)** TDI is notified within this period by return of such product to TDI or its authorized distributor/dealer, transportation prepaid by user; **b)** the starter has been installed according to TDI's specifications; **c)** the starter has not been misused, abused, or improperly maintained by user; **d)** the defect is not the result of normal wear and tear; **e)** the starter has been repaired with parts manufactured or authorized by TDI; and **f)** TDI installation and repair procedures as outlined in the appropriate manual were properly followed.

Tech Development will repair, or at its option, replace the unit during the warranty period at no charge to the customer, provided it is returned to TDI with the proper return procedure.

Tech Development makes no other warranty, and implied warranties including any warranty or merchantability or fitness for a particular purpose are hereby disclaimed.

This warranty constitutes the entire obligation of Tech Development relating to the sale and use of such product, and TDI's maximum liability is limited to the purchase price of such product at the date of purchase. In no event shall TDI be liable for incidental, indirect, consequential, or special damages of any nature arising from the sale or use of such engine starter product.

## 6.0 OPERATOR'S TROUBLESHOOTING GUIDE

TROUBLE	PROBABLE CAUSE	SOLUTION
1. Air always flow through exhaust	A. Relay valve improperly installed.	A. Check typical installation diagram and correct
	B. Relay valve not sealing properly.	B. Check for damaged sealing ring, replace relay valve or damaged parts.
	C. Solenoid is not sealing, pressure remains in APP port of relay valve.	C. Check solenoid potential at the lead to ground should be 0. If not, fix ignition switch problem.
2. Starter engages but does not run.	A. Bad relay valve	A. Replace relay valve.
3. Starter does not run, small air flow from turbine exhaust or drive housing.	A. Nozzle blockage.	A. Remove blockage or obstruction from nozzles.
4. Starter does not run. Normal air flow from exhaust.	A. Excessive bends in the supply line.	A. Shorten length or straighten supply air line.
5. Pinion does not engage	A. Air pressure is too low	A. Increase air pressure to 40 -150 psig.
	B. Control lines to starter ports reversed.	B. Check installation diagram and correct.
	C. Solenoid valve not operating or plugged.	C. Check wiring and solenoid operation. Check for correct voltage. Correct wiring, remove blockage, or replace solenoid valve as needed.
	D. Damaged pinion teeth.	D. Replace pinion or starter drive as necessary.
6. Starter runs but engine cranks slowly or not at all.	A. Air pressure too low	A. Increase air pressure to 40 –150 psig.
	B. Excessive back pressure.	B. Check Exhaust Adapter
	C. Worn or broken starter drive.	C. Replace starter drive.
	D. Nozzle blocked or damaged.	D. Remove blockage or replace damaged parts.
7. Starter continues to operate after start button is released.	A. Solenoid valve is not sealing correctly.	A. See 1C above
	B. Relay valve is not sealing correctly.	B. See 1B above
8. Air tank pressure decays after extended shut down.	A. Air connections are not tight.	A. Tighten loose fittings. Repair or replace damaged fittings.
	B. Damaged air lines: crushed, frayed, and kinked.	B. Replace damaged lines.
	C. Relay valve is not sealing correctly.	C. See 1B above
	D. Solenoid valve is stuck open.	D. See 1C above



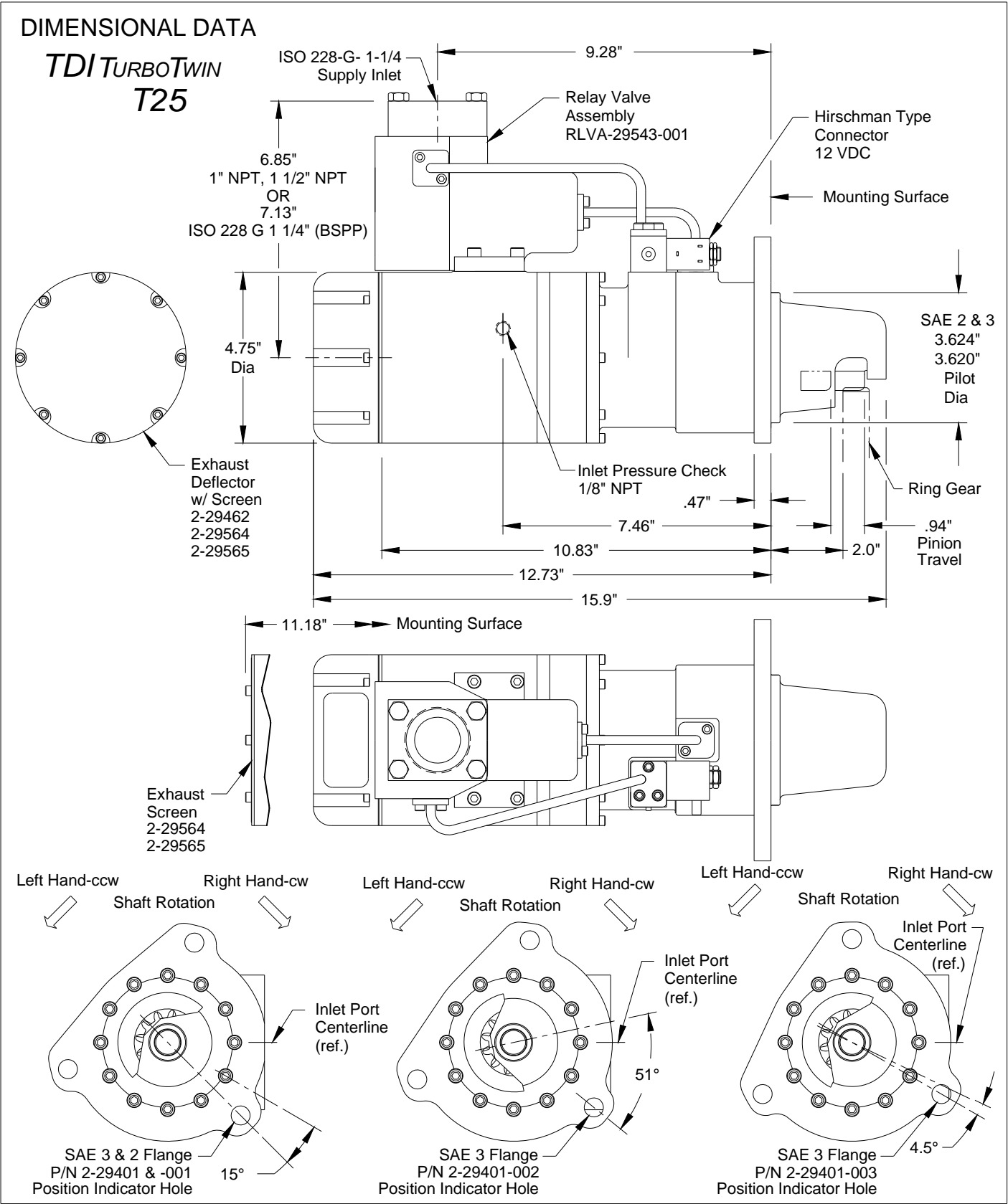

Figure 1. T25 Envelope Drawing

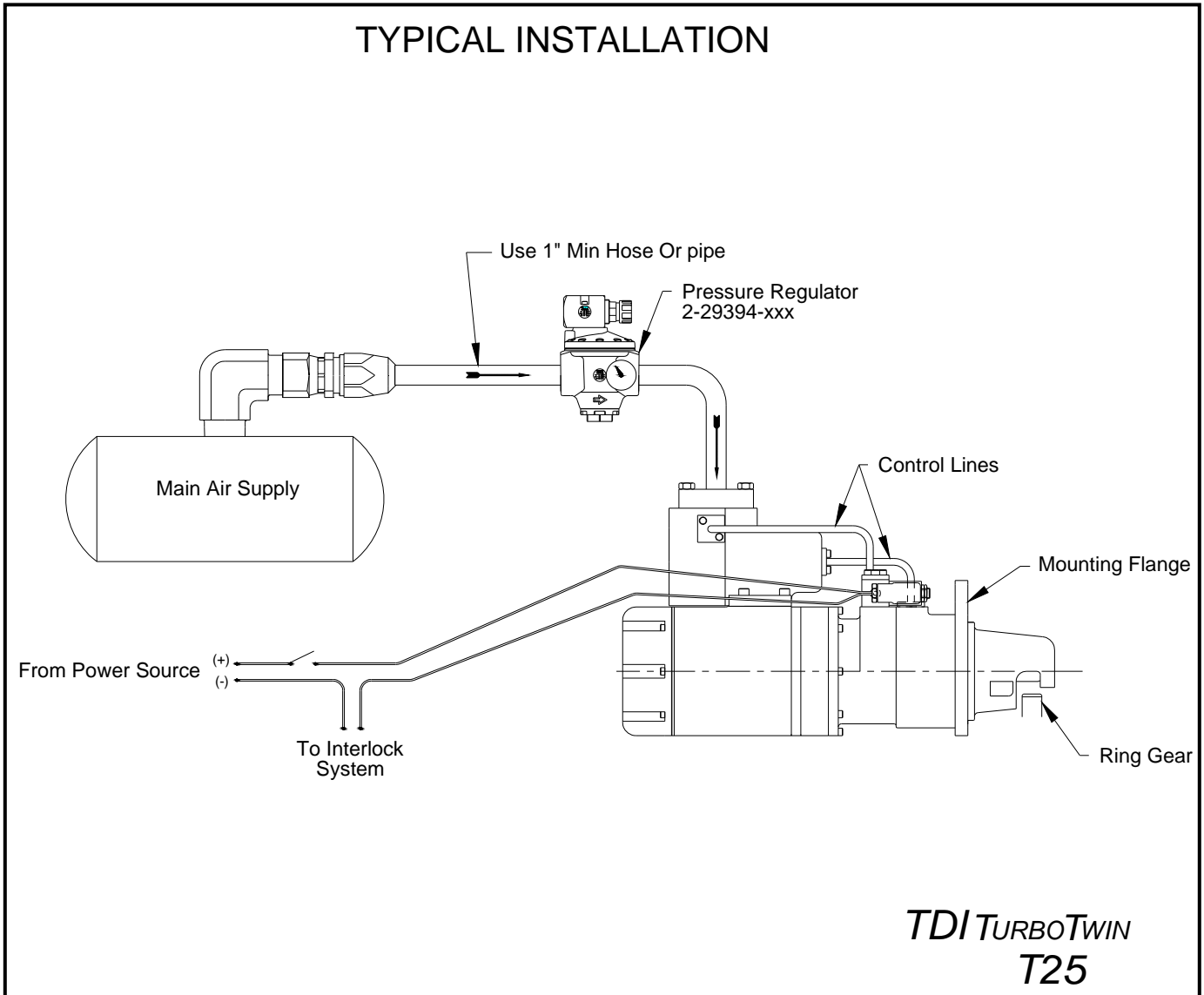

Figure 2. T25 Installation Diagram

