

TDI

TURBOTWIN™

Model T25

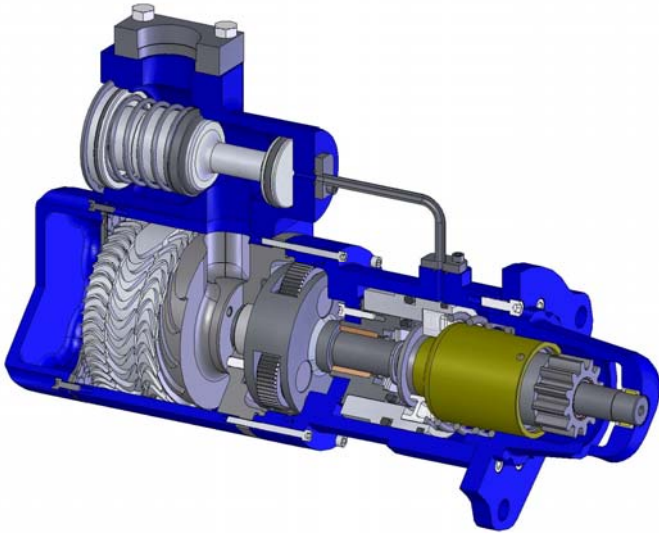

Model T25 **TURBOTWIN™** Engine Air Starters

APPLICATION VERSATILITY

- Suitable for starting diesel models up to 15 liters (900 CID).
- Engine applications include MTU BR1600, MAN D26/D28, Scania D16 and Volvo D116

CONTAMINATED SUPPLY

- Configured with the same rugged turbine motor design used in the complete line of **TURBOTWIN** starters.
- The **TURBOTWIN** motor is highly resistant to damage caused by wet or hard contaminated drive air/gas.

SIMPLICITY

- The integrated relay valve eliminates the need for lengthy pre-engagement lines simplifying installation and reducing costs.
- Features modular construction with serviceable parts providing users with simple and low cost overhaul.



From **TECH DEVELOPMENT**
6800 Poe Avenue • Dayton, OH 45413
Tel: 937-898-9600 • Fax: 937-898-8431

LOW AIR CONSUMPTION

- Efficient twin turbine motor delivers more torque using less air/gas than previous starter designs.
- Standard pressure (6 nozzle) and low pressure (12 nozzle) versions available.

NO MAINTENANCE DESIGN and ENVIRONMENTALLY SAFE

- Maintenance free design with grease-packed bearings for the life of the starter.
- No external lubrication required as there are no rubbing parts.
- Eliminates lubricator problems, installation expense, system maintenance, and the messy/hazardous oil film around the starter exhaust.

HEAVY DUTY CONSTRUCTION

- Constructed from durable, corrosion resistant, and high quality materials.
- Major components are made from high strength aluminum or steel alloy.

BROAD RANGE of OPERATION

- Lightweight at only 26 lbs. (12 Kg)...the T25 is capable of delivering over 20 HP (15 kW) at only 150 psig (10 BAR).
- Pressure ranges from 30 psig (2 BAR) to 150 psig (10 BAR).
- Compressed air and natural gas compatible.

BROAD RANGE of OPERATION

- The high horsepower of the turbine air motor combined with a planetary gear speed reducer results in a very efficient and reliable unit.
- Powered by a pair of axial flow turbines coupled to a planetary gear reduction set.

DEVELOPMENT HISTORY

- Tech Development introduced the first turbine technology for starting industrial engines in 1979.
- Features an innovative and more reliable turbine motor than anything on the market today.
- The *TURBO TWIN* T25 is the result of TDI's continuing turbine starter design innovations.

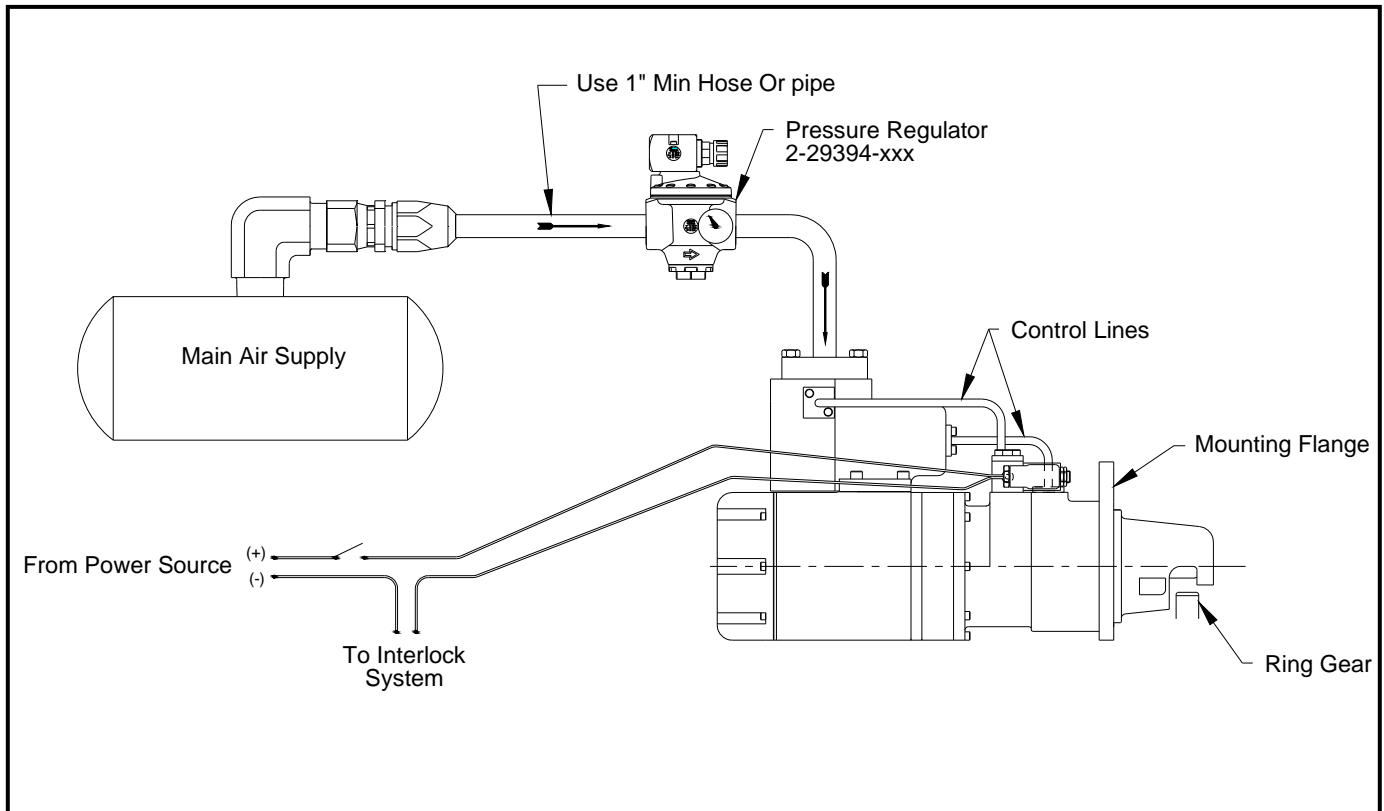

DIMENSIONAL DATA

**TDI TURBOTWIN
T25**

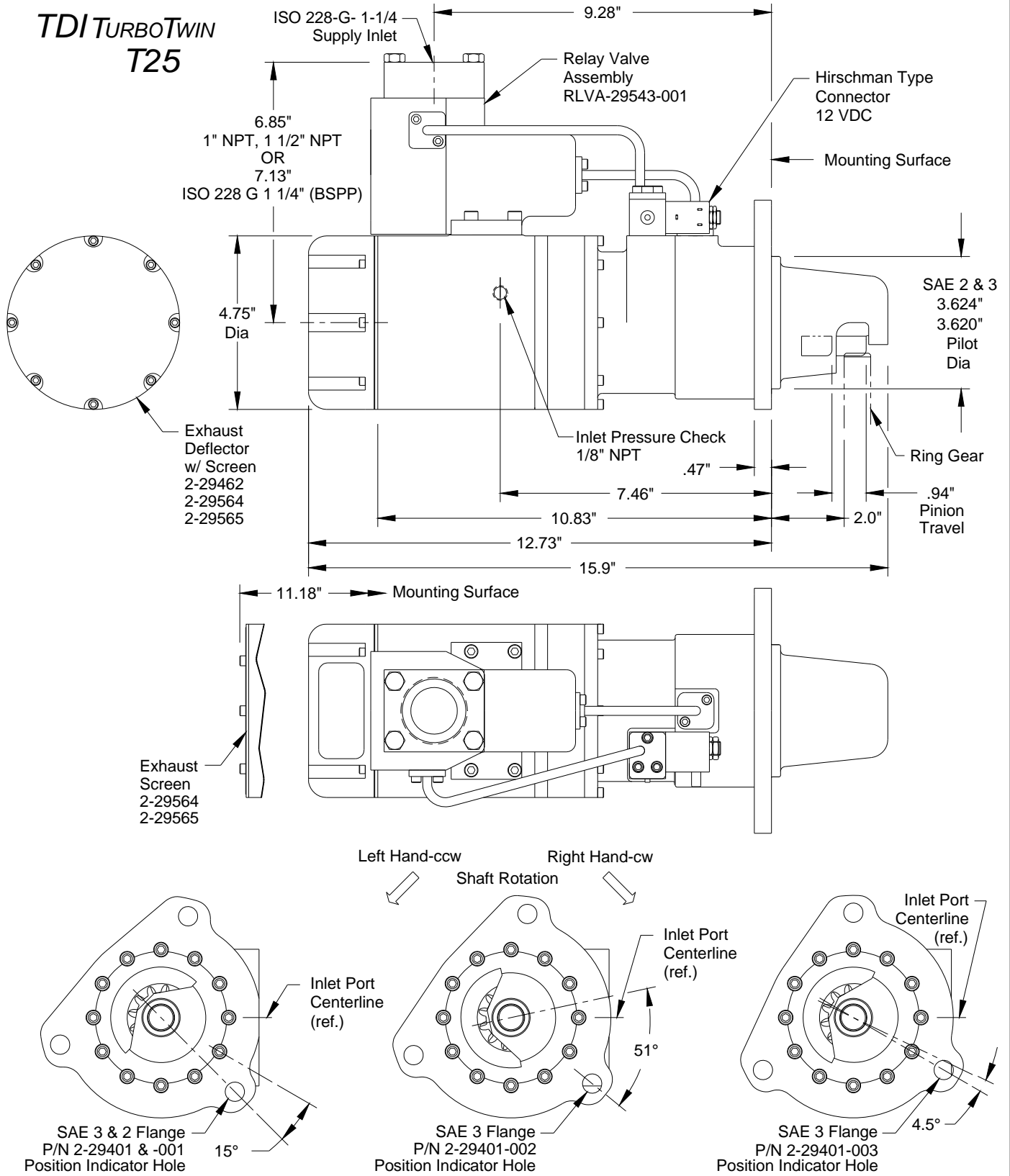

From **TECH DEVELOPMENT**

6800 Poe Avenue •Dayton, OH 45413

Tel: 937-898-9600 •Fax: 937-898-8431

