

# TDI **TURBOSTART™** Model 56S

## INDUSTRIAL GAS TURBINE STARTER

- The TDI *TURBOStart* Model 56S turbine powered starter motor is designed for application to Solar Saturn gas turbine engines. The Solar Saturn industrial engines are widely used for electrical power generation, industrial drives, and marine propulsion. The Model 56S was designed as a replacement for both the vane-type starter motor and the over-running and/or pneumatically driven jaw clutch assemblies. The 56S has a mounting flange and output shaft spline that mates with the accessory drive assembly starter mount pad.
- The 56S uses a robust turbine drive motor design. Properly installed, the turbine motor is highly resistant to damage caused by wet or hard contaminants in the drive air/gas.
- The Model 56S-07 starter can be used over a wide range of drive pressures from 80 psig (6 BAR) to 150 psig (10 BAR). It is suitable for operation on either compressed air or natural gas. On air it delivers 47 HP (35kW) of cranking power at 150 psig (10 BAR) with only 790 scfm. The starter materials have been selected to be compatible with "sour" natural gas and marine environments. For installations having less than 80 psig operational drive pressure at the starter inlet, low pressure versions can be ordered through your local TDI representative.
- The Model 56S provides significantly lower life cycle costs when compared to both the acquisition and operating costs of aviation derived starters. For industrial turbine engine application, the Model 56S provides superior performance and reliability at substantial savings over other starter alternatives.
- The starter can be operated using compressed air or natural gas pressures up to 150 psig (10 BAR). The 56S produces up to 140 HP on natural gas. See performance data.
- The Model 56S starter incorporates the TDI low mass turbine rotor designed to fracture in a precisely engineered and inherently safe manner should the starter ever over speed.
- The Model 56S features an internal (vented) oil sump, which functions as a stand-alone method of starter lubrication. The Model 56S also provides pressure lubrication ports which permit optional extension of the engine oil system to facilitate starter lubrication. This option is preferred by some operators when using the Model 56S.

**APPLICATION  
VERSATILITY**

**CONTAMINATED  
SUPPLY AIR/GAS**

**LOW AIR  
CONSUMPTION**

**LOWER COST**

**CRANKING POWER**

**SAFETY**

**LUBRICATION  
OPTIONS**

from **TECH DEVELOPMENT**  
6800 Poe Avenue • Dayton, OH 45413  
Tel: 937-898-9600 • Fax: 937-898-8431

- An axial flow turbine coupled to an integral planetary gear reduction set powers the Model 56S starter. The turbine power combined with the planetary gear reducer results in a very efficient and compact unit. The Model 56S incorporates a sprag type overrunning clutch in the starter gearbox drive train to provide a means of disengaging the starter from the gas turbine engine once the starter cutout speed has been reached. The Model 56S starter can be operated using either compressed air or natural gas.
- Tech Development Inc. introduced the first turbine technology for starting industrial engines in 1979. The *TURBOStart* 56 series air starters feature an innovative and more reliable turbine motor than any other gas turbine starter on the market today. The 56S is the result of TDI's continuing turbine starter design innovations.

## DESCRIPTION OF OPERATION

## DEVELOPMENT HISTORY

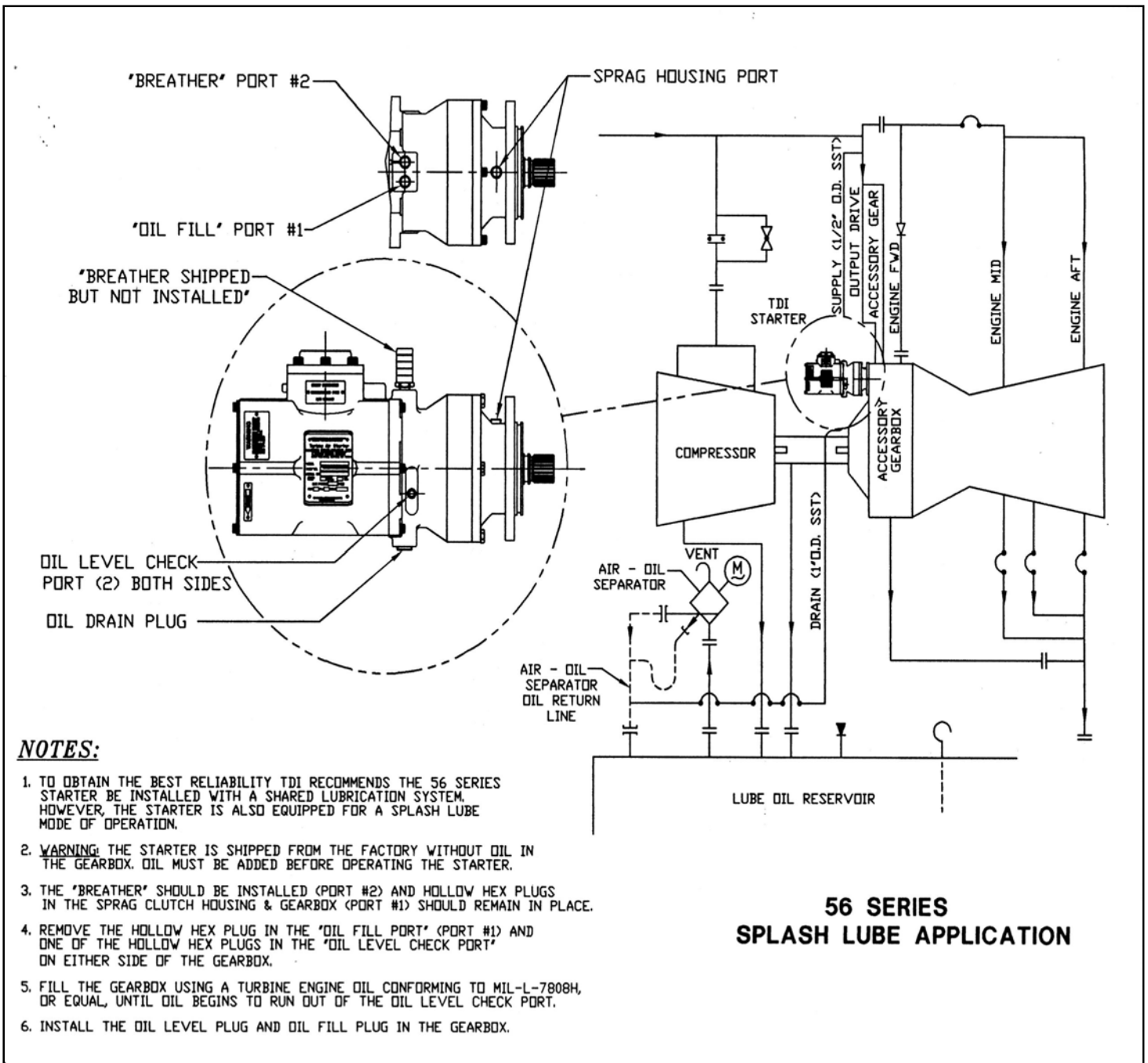

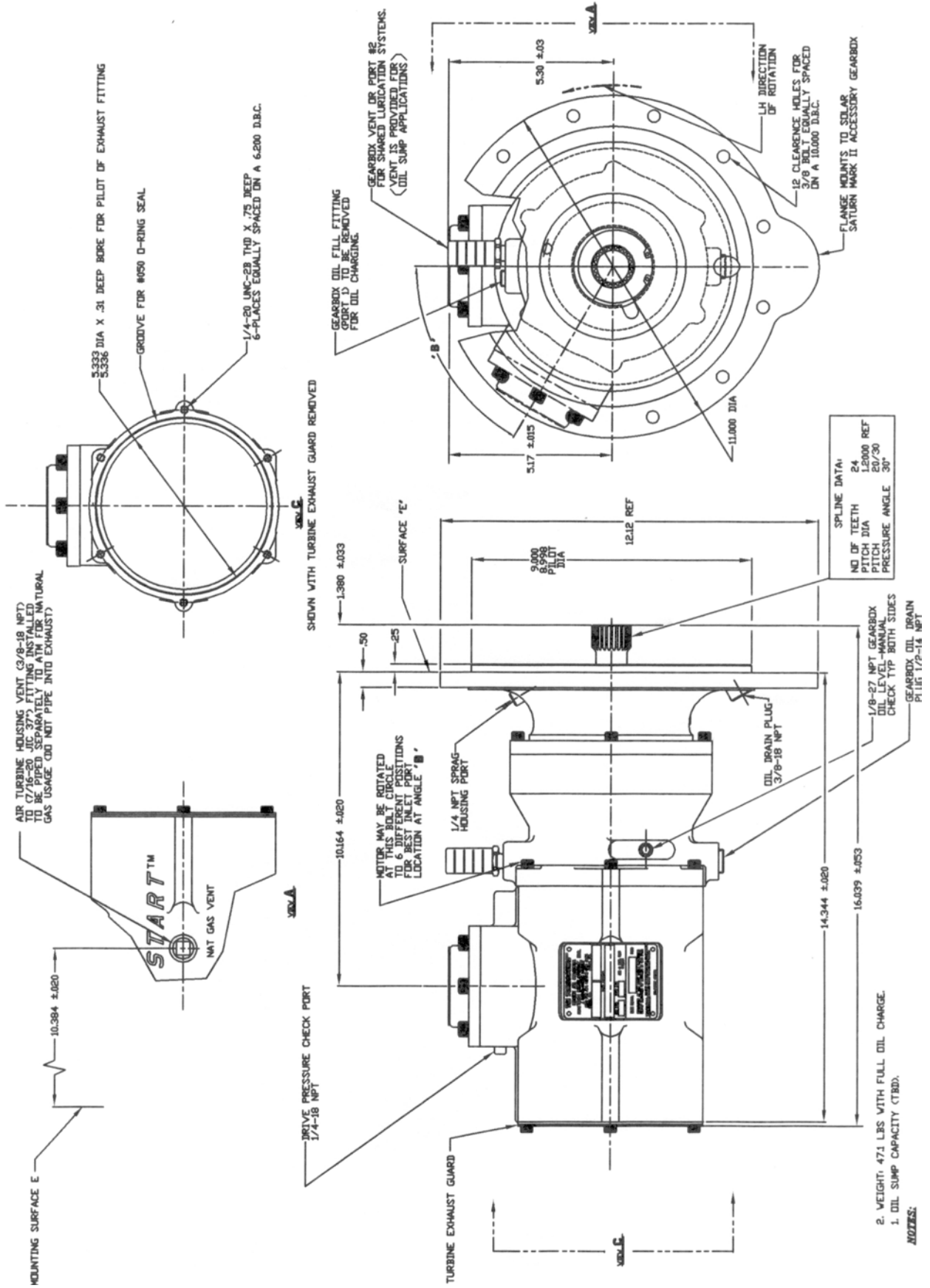

from **TECH DEVELOPMENT**

6800 Poe Avenue • Dayton, OH 45413  
 Tel: 937-898-9600 • Fax: 937-898-8431

**TDI TURBOSTART**  
**MODEL: 56S**  
**PERFORMANCE CURVE**

Model: 56S  
 7 Nozzles  
 70° F Compressed Air  
 9.0:1 Gear Ratio

INLET Pressure	FLOW (Scfm)	FLOW (Nm <sup>3</sup> /h)
60 PSIG	350	595
90 PSIG	485	825
120 PSIG	645	1097
150 PSIG	790	1343

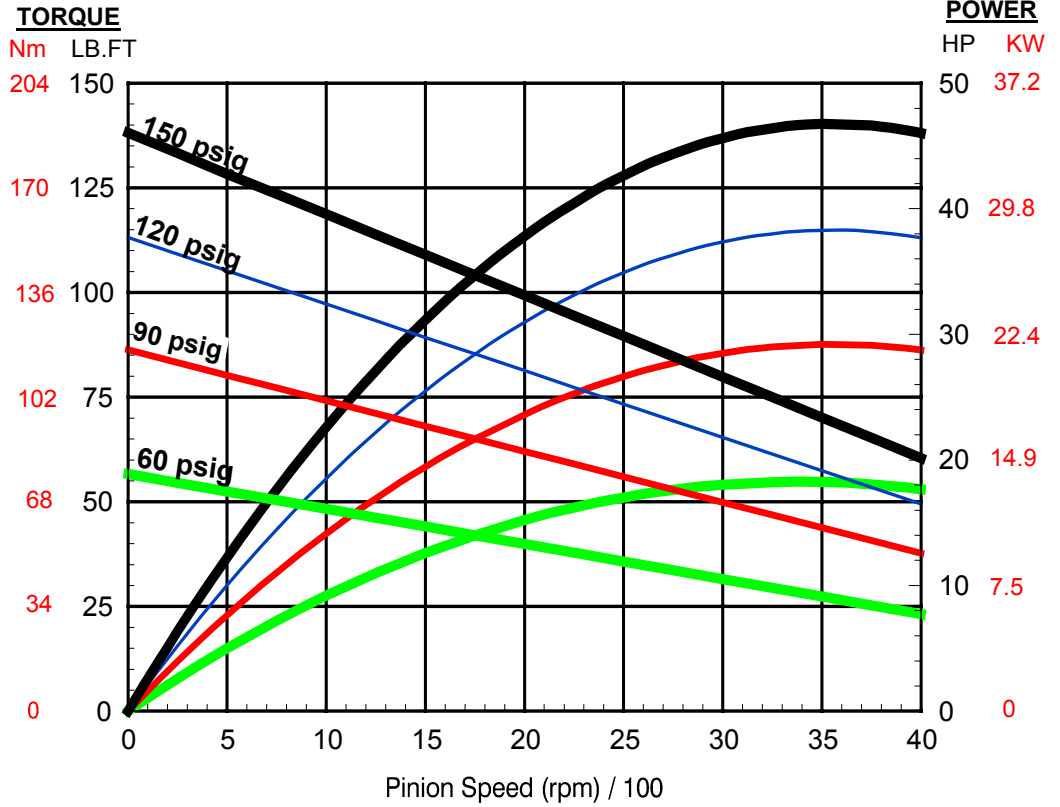

Model: 56S  
 21 Nozzles  
 70° F Compressed Air  
 9.0:1 Gear Ratio

INLET Pressure	FLOW (Scfm)	FLOW (Nm <sup>3</sup> /h)
60 PSIG	1050	1785
90 PSIG	1450	2465
120 PSIG	1940	3298
150 PSIG	2370	4029

