

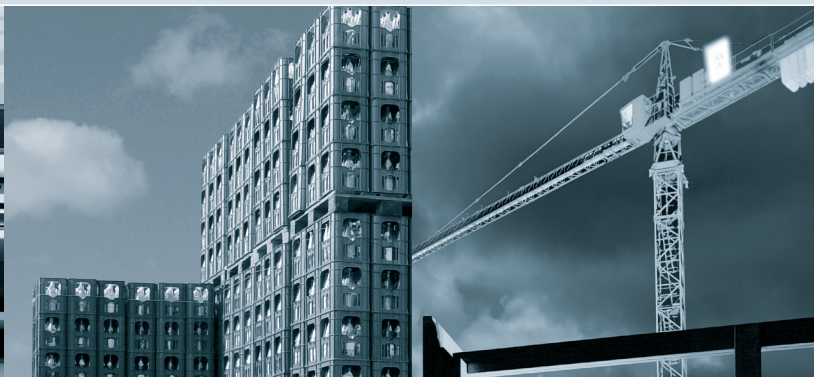

Catalog

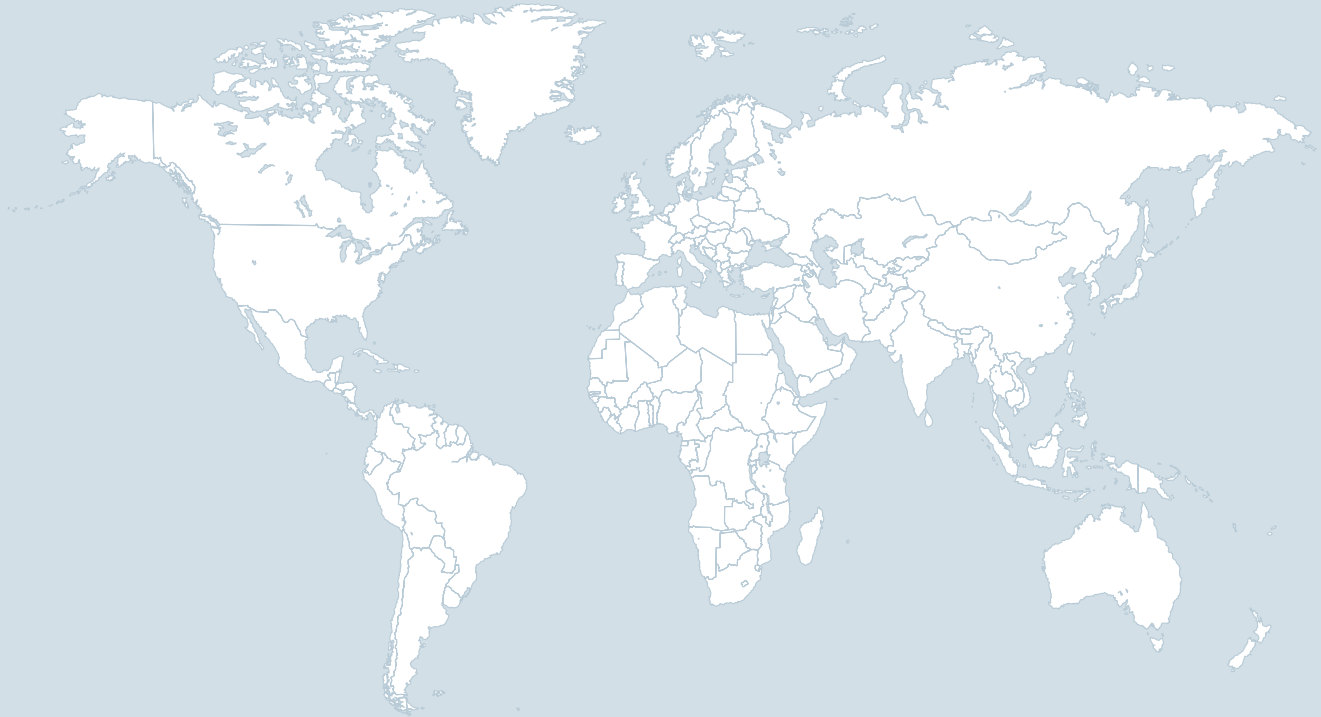

Gear Units



Introduction	7
Product Description	11
Nomenclature	25
Project Planning	41
Mounting Positions	69
Lubrication	103
Design and Operating Data	111
R / RX - Helical	137
F - theSnuggler® Helical	277
K - Helical Bevel	415
S - Helical Worm	579
W - Spiroplan®	687
Address Directory	713
Abbreviation Key	733
Index	735

- 1
- 2
- 3
- 4
- 5
- 6
- 7
- 8
- 9
- 10
- 11
- 12
- 13
- 14
- 15

1	Introduction	7
1.1	The SEW-EURODRIVE Group of Companies.....	7
1.2	Products and systems from SEW-EURODRIVE	8
1.3	Additional documentation	10
1.4	Copyright	10
2	Product Description.....	11
2.1	General information	11
2.2	Environmental protection	14
2.3	Extended storage.....	15
2.4	Important ordering information.....	16
2.5	Nameplate information.....	19
2.6	Input components	20
3	Nomenclature	25
3.1	Overview	25
3.2	Shaft and flange combinations	30
3.3	Input assemblies.....	39
4	Project Planning	41
4.1	List of application variables.....	41
4.2	Project planning assistance	42
4.3	Selection procedure.....	43
4.4	Gear efficiency and thermal losses.....	44
4.5	Service factor and inertia	46
4.6	Axial forces and overhung loads.....	51
4.7	AM adapter with IEC/NEMA motor	55
4.8	AR adapter with torque limiting coupling	57
4.9	AD input shaft	60
4.10	RM - extended bearing housing.....	64
4.11	DUO - Oil aging monitor	67
5	Mounting Positions.....	69
5.1	General information	69
5.2	R-series helical	72
5.3	F-series helical-parallel.....	77
5.4	K-series helical-bevel.....	80
5.5	S-series helical-worm	93
5.6	SPIROPLAN®.....	99
6	Lubrication	103
6.1	Greases and table keys	103
6.2	Lubricant tables	104
6.3	Fill quantities.....	106
7	Design and Operating Data.....	111
7.1	Tolerances	111
7.2	Foot or flange mounting.....	112
7.3	Torque arm mounting	112
7.4	TorqLOC® mounting system	113

7.5	Hollow shaft with key	115
7.6	Hollow shaft with key - Standard design.....	116
7.7	Hollow shaft with key - Recommended design.....	119
7.8	Bolts and eyebolts	124
7.9	Reduced backlash	125
7.10	Flange detail dimensions - RF.. and R..F	126
7.11	Flange detail dimensions - FF.., KF.., SF.. and WF..	127
7.12	Flange detail dimensions - FAF.., KAF.., SAF.. and WAF..	128
7.13	Hollow shaft covers.....	129
7.14	Chamfers on hollow shafts	130
7.15	General dimension notes.....	131
7.16	Explanation of dimensions.....	132
7.17	Overview of selection tables	135
8	R / RX - Helical.....	137
8.1	R/RX.. AM.....	137
8.2	R / RX.. AD	173
8.3	R/RX.. AM.. [NEMA dimensions]	220
8.4	R/RX..AM.. [IEC dimensions].....	263
8.5	R.. R.. AM.. [compound dimensions].....	266
8.6	R/RX.. AD.. [dimensions].....	267
8.7	R.. R.. AD.. [compound dimensions].....	269
8.8	R/RX.. AD/P [dimensions].....	270
8.9	R.. AR.. [dimensions].....	272
8.10	Output shaft sizes	274
9	F - the Snuggler® Helical.....	277
9.1	F.. AM	277
9.2	F.. AD.....	305
9.3	F.. AM.. [NEMA dimensions].....	344
9.4	F..AM.. [IEC dimensions].....	398
9.5	F.. R.. AM.. [compound dimensions].....	401
9.6	F.. AD.. [dimensions]	402
9.7	F.. R.. AD.. [compound dimensions].....	404
9.8	F.. AD../P [dimensions]	405
9.9	F.. AR.. [dimensions]	407
9.10	Output shaft sizes	409
10	K - Helical Bevel.....	415
10.1	K.. AM	415
10.2	K.. AD	449
10.3	K.. AM.. [NEMA dimensions]	492
10.4	K.. AM.. [IEC dimensions].....	562
10.5	K.. R.. AM.. [compound NEMA dimensions].....	565
10.6	K.. AD.. [dimensions]	566
10.7	K.. R.. AD.. [compound dimensions].....	568
10.8	K.. AD../P [dimensions].....	569
10.9	K.. AR.. [dimensions]	571
10.10	Output shaft sizes	573

11 S - Helical Worm	579
11.1 S.. AM	579
11.2 S.. AD	592
11.3 S.. AM.. [NEMA dimensions]	612
11.4 S.. AM.. [IEC dimensions].....	646
11.5 S.. R.. AM.. [compound dimensions]	648
11.6 S.. AD.. [dimensions]	649
11.7 S.. R.. AD.. [compound dimensions].....	651
11.8 S.. AD../P [dimensions].....	652
11.9 S.. AR.. [dimensions]	653
11.10 Mechanical ratings	654
11.11 Output shaft sizes	682
12 W - Spiroplan®	687
12.1 W.. AM	687
12.2 W.. AD	691
12.3 W.. AM.. [NEMA dimensions]	695
12.4 W.. AM.. [IEC dimensions].....	704
12.5 W.. AD.. [dimensions]	705
12.6 W.. AR.. [dimensions]	707
12.7 Output shaft sizes	708
13 Address Directory	713
14 Abbreviation Key	733
15 Index	735

1 Introduction

1.1 The SEW-EURODRIVE Group of Companies

Global presence

SEW-EURODRIVE is driving the world with innovative drive solutions for all branches and every application. Products and systems from SEW-EURODRIVE are used in a multitude of applications worldwide. Be it in the automotive, building materials, food and beverage or metal-processing industry, the decision to use drive technology "made by SEW-EURODRIVE" stands for reliability and quality.

We currently have 15 manufacturing plants, 79 assembly plants in 48 countries, and a comprehensive range of services that represents our commitment to outstanding quality.

Complete solutions

The SEW-EURODRIVE modular concept offers millions of combinations. This wide selection enables you to choose the correct drive for all applications, based upon your required speed, torque, available space, and ambient conditions. We offer many gradual sizes of gear units so there is always a unit that closely matches your torque requirement to provide the best economic solution and to prevent unnecessary oversizing.

Gearmotors are powered by MOVITRAC[®] or MOVIDRIVE[®] frequency inverters or MOVIAXIS[®] multi-axis servo inverters, providing a single-source solution for all of your needs. Whether its electronics or mechanical systems, SEW-EURODRIVE is responsible for the complete development, production and assembly of all products in order to provide the utmost in flexibility.

Products of the servo drive system provide precision and dynamics, including low backlash servo gear units, compact servomotors, and MOVIAXIS[®] multi-axis servo inverters. From single-axis or multi-axis applications all the way to synchronized processes, servo drive systems by SEW-EURODRIVE offer a flexible and customized implementation of your application.

For economical decentralized installations, SEW-EURODRIVE offers components such as MOVIMOT[®], the gearmotor with integrated frequency inverter or MOVI-SWITCH[®], the gearmotor with integrated switching and protection. Our hybrid cables have been designed specifically to ensure cost-effective solutions, independent of the system size or system type.

The latest developments from SEW-EURODRIVE include: MOVITRANS[®] - contactless energy transfer, MOVIPRO[®] - decentralized drive control, and MOVIFIT[®] - decentralized intelligence.

Power, quality, and sturdy design define the industrial gear units available from SEW-EURODRIVE. With high torque capacity and a modular concept, the industrial gear units once again provide optimum adaptation of a standard product for a wide range of demanding applications.

Worldwide partner

Our global presence, extensive product range, and broad spectrum of services make SEW-EURODRIVE the ideal partner for demanding applications in all industries and applications.

1.2 Products and systems from SEW-EURODRIVE

The products from SEW-EURODRIVE are divided into the following 4 groups:

1. Gearmotors and frequency inverters
2. Servo drive systems
3. Decentralized drive systems
4. Industrial gear units

Consult the following tables to locate the products included in the respective groups:

1. Gearmotors and frequency inverters		
Gear units/gearmotors	Motors	Frequency inverters
<ul style="list-style-type: none"> • Helical gear units/helical gearmotors • Parallel-shaft helical gear units/parallel-shaft helical gearmotors • Helical-bevel gear units/helical-bevel gearmotors • Helical-worm gear units/helical-worm gearmotors • SPIROPLAN® right-angle gearmotors • Drives for electrified monorail systems • Multi-speed gearmotors • Variable speed gear units/variable speed gearmotors • Aseptic gearmotors 	<ul style="list-style-type: none"> • Asynchronous AC motors/ AC brakemotors • Multi-speed AC motors/ AC brakemotors • Energy-efficient motors 	<ul style="list-style-type: none"> • MOVITRAC® frequency inverters • MOVIDRIVE® inverters • Control, technology and communication options for inverters

2. Servo drive systems		
Servo gear units/servo gearmotors	Servomotors	Servo drive inverters/servo inverters
<ul style="list-style-type: none"> • Low backlash planetary servo gear units/planetary gearmotors • Low backlash helical-bevel servo gear units/helical-bevel gearmotors • R, F, K, S, W gear units/gearmotors 	<ul style="list-style-type: none"> • Synchronous servomotors/servo brakemotors 	<ul style="list-style-type: none"> • MOVIDRIVE® servo inverters • MOVIAXIS® multi-axis servo inverters • Control, technology and communication options for servo drive inverters and servo inverters

3. Decentralized drive systems		
Decentralized drives	Communication and installation	Contactless energy transfer
<ul style="list-style-type: none"> • MOVIMOT® gearmotors with integrated frequency inverter • MOVIMOT® motors/brakemotors with integrated frequency inverter • MOVI-SWITCH® gearmotors with integrated switching and protection function • MOVI-SWITCH® motors/brakemotors with integrated switching and protection function 	<ul style="list-style-type: none"> • Fieldbus interfaces • Field distributors for decentralized installation • MOVIFIT® product range <ul style="list-style-type: none"> – MOVIFIT® MC for controlling MOVIMOT® drives – MOVIFIT® SC with integrated electronic motor switch – MOVIFIT® FC with integrated frequency inverter 	<ul style="list-style-type: none"> • MOVITRANS® system <ul style="list-style-type: none"> – Stationary components for energy supply – Mobile components for energy consumption – Line cables and installation material

4. Industrial gear units
<ul style="list-style-type: none"> • Helical gear units • Bevel-helical gear units • Planetary gear units

Products and systems covering several product groups
<ul style="list-style-type: none"> • Operator terminals • MOVI-PLC® drive-based control system

In addition to products, SEW-EURODRIVE offers a comprehensive range of services, including the following:

- Technical application assistance
- Application software
- Training
- PT Pilot® online configurator/quotation program
- 2D/3D CAD drawings
- Extensive technical documentation
- International customer service

For comprehensive information and services, visit our homepage at

→ www.seweurodrive.com

You may also visit our online configuration program at

→ www.ptpilot.com

1.3 Additional documentation

Content of this publication

This "Gear Units" catalog provides a detailed description of the following product groups from SEW-EURODRIVE:

- R.., F.., K.., S.., and SPIROPLAN® W gear units in combination with
 - AM adapter
 - AD input shaft assembly
 - AR Torque limiting coupling

For information on options for the motors, refer to the catalogs "DR.. AC Motors".

For additional information on R.., F.., K.., S.. and SPIROPLAN® W gear units in combination with the AQ adapter for servomotors, refer to the "Servo Gear Units" catalog.

Additional documentation

The following catalogs are available from SEW-EURODRIVE in addition to this "Gear Units" catalog:

- Servo gear units
- Synchronous servo gearmotors
- DRN.. gearmotors
- DR.. AC motors
- MOVIMOT® gearmotors

These catalogs offer the following information:

- Product descriptions
- Technical data and inverter assignments
- Important information about tables and dimension sheets
- Description of the different types
- Selection tables
- Dimension sheets
- Technical data
- Notes on adapter mounting

1.4 Copyright

© 2016 - SEW-EURODRIVE. All rights reserved.

Copyright law prohibits the unauthorized duplication, modification, distribution, and use of this document, in whole or in part.

2 Product Description

2.1 General information

Ambient temperature

Gear units and gearmotors from SEW-EURODRIVE can be operated in a wide ambient temperature range. The following standard temperature ranges are permitted for filling the gear units according to the lubricant table:

Gear unit	Filled with	Permitted standard temperature range
R, F, and K	CLP(CC) VG220	-15°C ... +40°C
S	CLP(CC) VG680	0°C ... +40°C
W	CLP(SEW-PG) VG460	-20°C ... +40°C

The rated data of the gear units and gearmotors specified in SEW-EURODRIVE catalogs refer to an ambient temperature of +25°C (77°F).

With proper project planning, gear units and gearmotors from SEW-EURODRIVE can operate from -40°C to +60°C (-40°F to +140°F). Project planning must consider special operating conditions and use appropriate lubricants and seals. It is especially important for the following gear units:

- R, K, F gear units > size 87 with small ratios
- All S gear units (helical-worm) with small ratios

SEW-EURODRIVE will gladly perform this project planning for you. Or, you may visit www.ptpilot.com for complete specifications and quotations. PT Pilot® automatically calculates your oil sump temperature based upon your mounting position and ambient temperature. Where applicable, PT Pilot® adds synthetic oil and FKM seals for proper protection against heat.

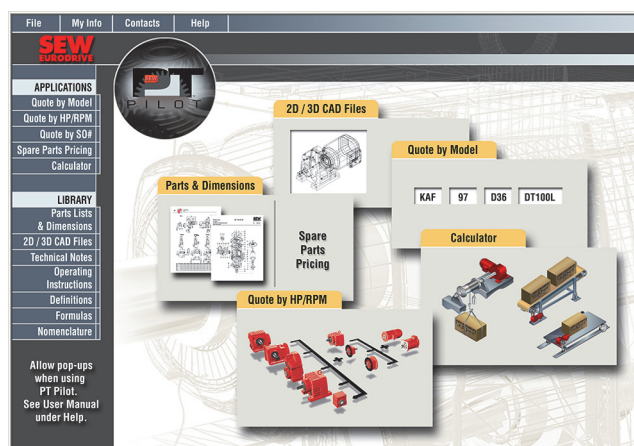

If the drive is to be operated by a frequency inverter, you must also consider the thermal effects of inverter operation during your project planning.

- Altitude** Due to the low air density at high altitudes, heat dissipation on the surface of motors and gear units decreases. The rated data listed in the catalog applies to an installation altitude of maximum 3280 feet above sea level. Project planning must consider Installation altitudes of more than 3280 feet to ensure proper cooling.
- Power and torque** The power and torque ratings listed in the catalogs refer to mounting position M1 and similar mounting positions in which the input stage is not completely submerged in oil. In addition, the gear units are assumed to be standard versions with standard lubrication and normal ambient conditions.
- Noise** The noise levels of all SEW-EURODRIVE gear units, motors and gearmotors are well within the maximum permitted noise levels set forth in the VDI guideline 2159 for gear units and IEC/EN 60034 for motors.
- Paint** Gear units from SEW-EURODRIVE are painted with "RAL 5001 blue" as standard. Alternate paints include RAL 7031 blue/gray, metallic gray, black, and white. Special paints are available upon request.
- Ambient air flow** Gear units and gearmotors must be mounted on the driven machine in such a way that both axially and radially there is enough space left for unimpeded air flow.
- Compound gear units** Particularly low output speeds are possible by using a compound (multi-stage) gear unit. These units contain an additional helical gear unit (RF style) on the input in order to achieve much higher ratios than those in a single gear unit.
It may be necessary to limit the motor power or to provide torque overload protection to ensure that the maximum permissible output torque of the gear unit is not exceeded.
- Reduced backlash** Helical (R-series), the Snuggler® helical (F-series) and helical-bevel (K-series) gear units with reduced backlash are available in gear unit sizes 37 and larger. The circumferential backlash of these gear units is considerably less than that of the standard version; therefore, positioning tasks can be performed with great precision. The circumferential backlash is specified in angular minutes ['] in the technical data. The circumferential backlash for the output shaft is specified without load (max. 1% of the rated output torque) with the gear unit input end blocked. For further information, refer to chapter "Reduced backlash gear units" on page 125.
- RM gear units** RM gear units are a special type of helical gear unit with an extended output bearing hub. They are designed especially for agitation applications and allow for high overhung loads, axial loads, and bending moments. Excluding overhung load ratings, all other ratings are the same as for standard helical gear units. See special project planning notes for RM gearmotors in the "Project Planning/RM gear units" chapter on page 64.

SPIROPLAN® gear units

SPIROPLAN® right-angle gear units (W-series) are robust right-angle gear units with either single or two stage gearing. Unlike the helical-worm gear units (S-series) that use both bronze and metal gears with sliding friction, the SPIROPLAN® units use only steel gears with a special meshing pattern that incorporates both sliding and rolling friction for greater efficiency.

The shorter design along with the aluminum housing of the SPIROPLAN® produce a very compact and lightweight drive solution.

The wear-free gearing and the life-long lubrication allow for long periods of maintenance-free operation. For maximum versatility, the hole spacing on the feet is the same on all three sides. In addition, the shaft height remains the same regardless of which side the unit is mounted.

Two different flange diameters are available. And upon request, SPIROPLAN® gearmotors can be equipped with a torque arm.

K..19 - K..49 hypoid gear units

The latest edition to the SEW-EURODRIVE family of gearmotors is the K..19 - K..49 units. These right-angle units contain 2-stage hypoid gearing for even greater efficiency than the SPIROPLAN®. Total efficiency ranges from 90% to 96%, depending on the ratio.

Weights

Please note that all weights shown in the catalogs exclude the weight of the oil. The oil weight varies according to gear unit type and gear unit size. The amount of lubricant varies, depending upon the mounting position. Please refer to "Lubricants" in the "Design and Operating Notes" chapter for recommended oil fill quantities. For a more precise weight, refer to the order confirmation.

Shaft diameters

All gear units are available with either metric or inch shafts on the input and the output. In addition, several diameters are available for each gear unit at no extra charge. See the dimension pages beginning on pages 272 (R-series), 407 (F-series), 571 (K-series), 680 (S-series), and 706 (W-series).

2.2 Environmental protection

OS Surface protection

SEW-EURODRIVE offers surface protection for gear units operating under various environmental conditions. Instead of the standard surface protection, motors and gear units are available with surface protection OS2 and OS4 as an option.

Surface Protection	Procedure	Application
OSG	Dip Primer Primer	Primer only
		Additional coating to be applied by customer
Standard	Dip Primer Acrylic Top Coat	Normal ambient conditions
		Indoors for climate controlled buildings with clean atmospheres (ex: shops, airports)
OS2	Dip Primer Acrylic Primer Acrylic Top Coat + UV	Medium environmental impact - with UV protection
		Indoors with high humidity or splashing water (ex: depots, sports halls) Outdoors subject to direct weathering and low pollution (ex: amusement parks, water treatment facilities)
OS4	Dip Primer Epoxy Primer Polyurethane Top Coat Polyurethane Clear Coat	High environmental impact - with UV protection Indoor environments with permanent condensation, heavy washdown, severe atmospheric or chemical contamination. Withstands chemical, acidic or caustic agents used for washdown cleaning. Resistant to solvents, grease, sulfur dioxide, and salt. (ex: food processing, breweries, dairies, chemical plants, coastal areas with high salinity)

Seal and shaft protection

Feature	Design	Application
FKM oil seal	High quality material	Drives subject to chemicals or high temperature
PTFE oil seal	High quality material	Drives subject to chemicals
Stainless steel output shaft	Surface protection through non-corrosive material. All TorqLOC® shafts are available in stainless steel.	Demanding applications where anti-corrosion is mandatory.

NOCO® fluid

As standard, SEW-EURODRIVE supplies NOCO® fluid with every hollow shaft gear unit to provide corrosion protection. Use NOCO® fluid for lubrication when installing hollow shaft gear units. Care should be taken so that it is not applied to the compression surfaces of a shrink disc or a TorqLOC® clamping collar.

Using this fluid helps to prevent contact corrosion and makes it easier to disassemble the drive at a later time. NOCO® fluid is also suitable for protecting machined metal surfaces that do not have corrosion protection, such as parts of shaft ends or flanges.

NOCO® fluid is a food grade substance according to NSF-H1, as noted by the identification label on its packaging.

2.3 Extended storage

You can order gear units prepared for "Extended Storage." SEW-EURODRIVE recommends the "Extended Storage" type for storage periods longer than 9 months.

In this case, a VCI (volatile corrosion inhibitor) is added to the lubricant. Please note that this VCI corrosion inhibitor is only effective in a temperature range between -25°C to +50°C (-13°F to +120°F). In addition, the flange contact surfaces and shaft ends are treated with an anti-corrosion agent.

If not specified otherwise on your order, the gear unit with "extended storage" option will be supplied with OS2 surface protection. You can order OS4 as an option.

INFORMATION	
	<p>Gear units must remain tightly sealed until placed into operation to prevent the VCI corrosion protection agent from evaporating.</p> <p>Gear units will be supplied with oil to the appropriate level depending on the specified mounting position (M1 to M6). Always check the oil level before you start operating the gear unit for the first time.</p>

Storage conditions

Observe the storage conditions specified in the following table for extended storage:

Climate zone	Packaging ¹⁾	Storage location ²⁾	Storage duration
Temperate (Europe, USA, Canada, China and Russia, excluding tropical zones)	Packed in containers and sealed in a plastic wrap that contains desiccant and a moisture indicator.	With roof, protected against rain and snow. No shock loads.	Up to three years with regular checks of the packaging and moisture indicator (humidity < 50%).
	Open	With roof, enclosed at constant temperature and humidity (40°F < T < 140°F, 50% relative humidity). No sudden temperature fluctuations. Controlled ventilation with filter (free from dust and dirt). Protected against aggressive vapors and shocks.	Two years or more with regular inspections. Check for cleanliness and mechanical damage during inspection. Check corrosion protection.
Tropical (Asia, Africa, Central and South America, Australia, New Zealand excluding temperate zones)	Packed in containers and sealed in a plastic wrap that contains desiccant and a moisture indicator.	With roof, protected against rain and shocks.	Up to three years with regular checks of the packaging and moisture indicator (humidity < 50%).
	Protected against insect damage and mildew by chemical treatment.	Open	Two years or more with regular inspections. Check for cleanliness and mechanical damage during inspection. Check corrosion protection.

1) Packaging must be accomplished by an experienced company using the packaging materials that have been explicitly specified for the particular application.

2) SEW-EURODRIVE recommends storing the gear units in the same orientation as the mounting position that is shown on the nameplate.

2.4 Important ordering information

	INFORMATION
	The following information is required when ordering a gear unit.

Direction of rotation of the output shaft

When ordering a gear unit with an adapter or input shaft that contains a backstop, it is necessary to indicate the direction of rotation of the output shaft. The direction is determined by looking directly at the output shaft. For right-angle gear units with a double output shaft (containing shaft ends at both A and B), the direction must be specified as looking into side A.

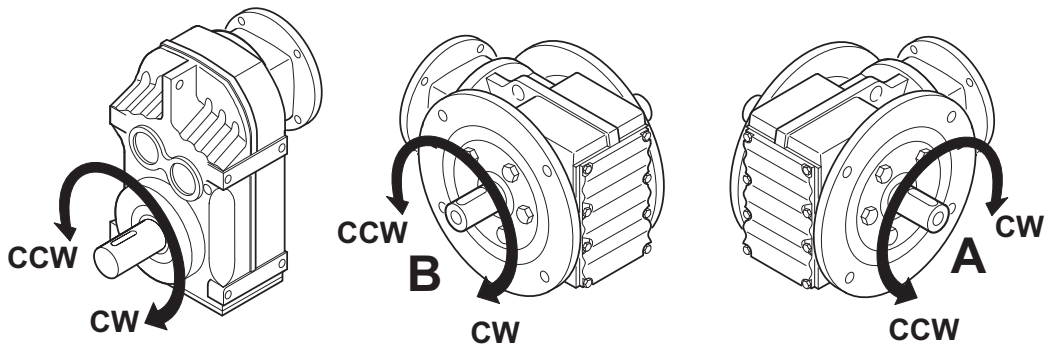

50290AXX

As viewed at the output shaft: CW = Clockwise
CCW = Counterclockwise

Position of the output shaft and flange

For right-angle gear units, the position of the output shaft and the output flange must also be specified:

- A or B
- AB = flange and/or shaft on both sides

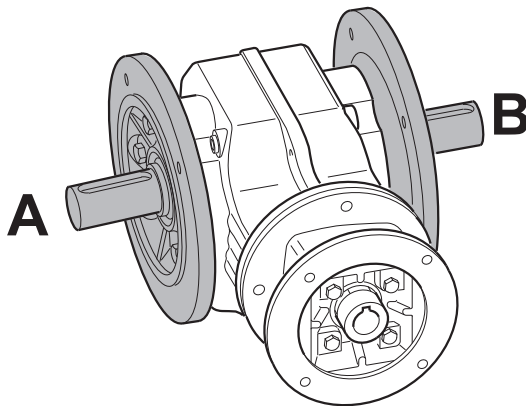

50296AXX

Position of shaft entry side for right-angle gear units

For shaft mounted right-angle gear units with either a shrink disc (ex. KH) or TorqLOC® (ex. KT), you must indicate whether A or B is the entry. The entry is the side that the customer's solid shaft first enters during installation. Therefore, it is the side closest to the customer's machine.

2

NOTE: on gear units with a TorqLOC® shaft (ex. KT), a symmetrical shaft is available for entry on either A or B. Designation = AB

The shrink disk is always located opposite the entry side. Thus, in the figure below, the entry side is A and the shrink disk side is B.

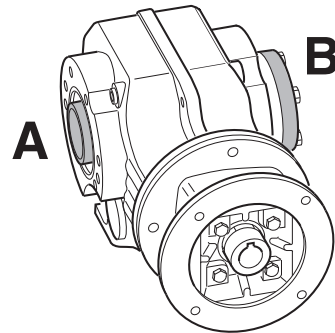

50297AXX

Position of torque arm for right-angle gear units

S-series

The figure below shows the side and degree options for the torque arm on S-series gear units. The bold degree position is the default location if no other degree is specified.

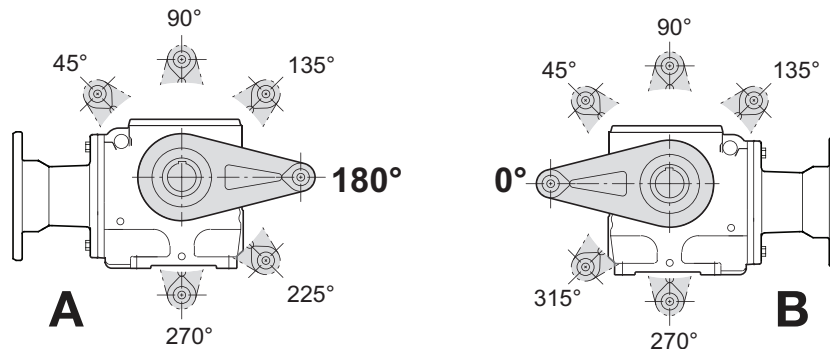

K-series

The figure below shows the side locations of the torque arm on K-series when looking into the front end of the gear unit, not when looking into the motor or input.

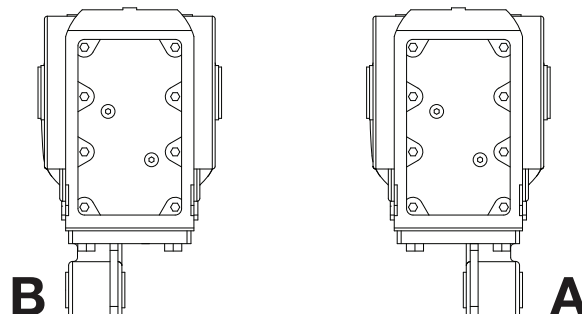

2 Product Description

Important ordering information

Mounting positions

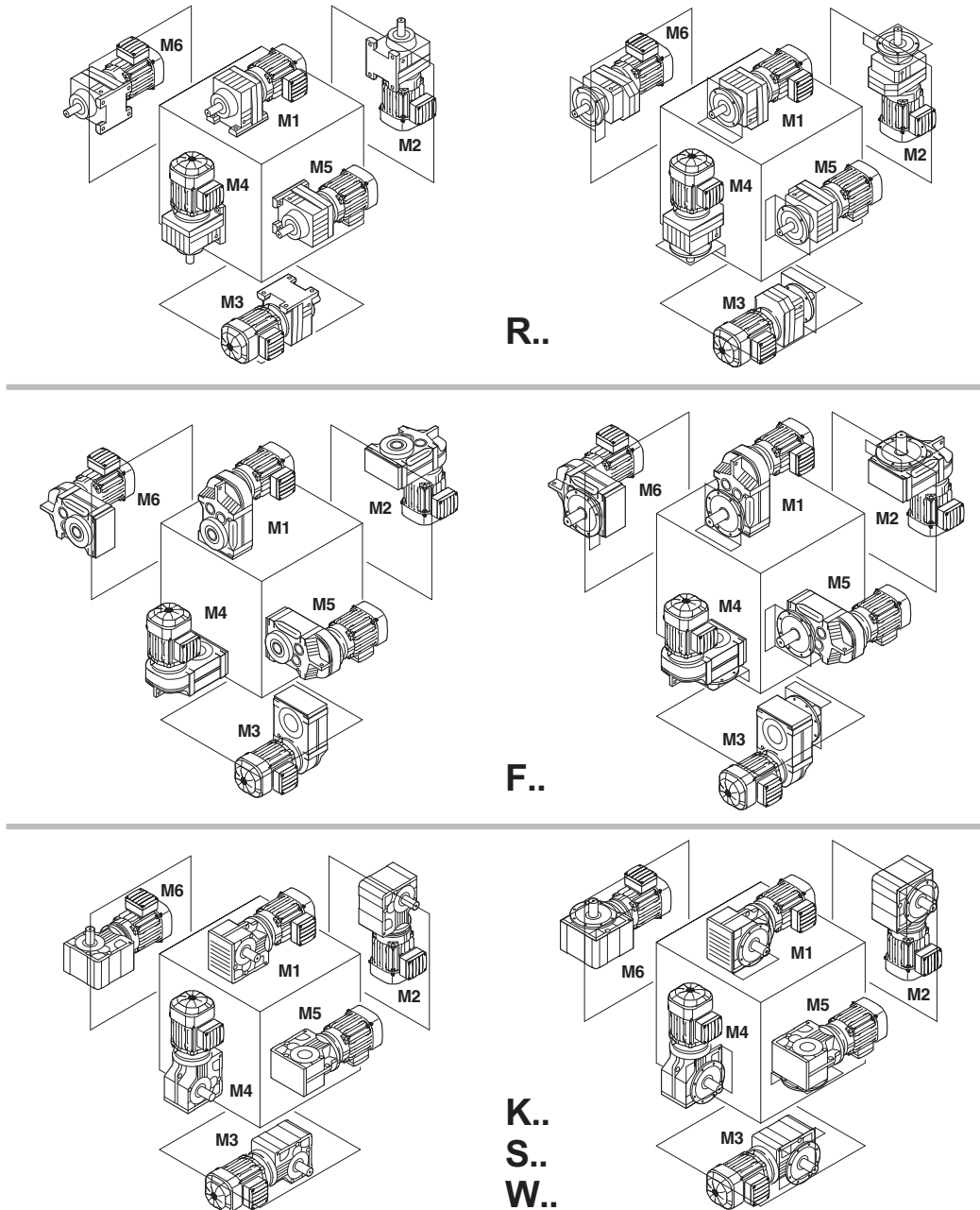

65873axx

Sample orders

The following examples show the information that is needed for each unit upon ordering.

Type (Examples)	Mounting position	Shaft position	Flange position	Entry Side	Shrink disk position	Direction of rotation on output	Torque Arm Side	Torque Arm Degree
K47../RS	M2	A	-	-	-	CW	-	-
SF77	M6	B	B	-	-	-	-	-
KT97/T	M4	-	-	B	A	-	B	-
KT107	M1	-	-	AB	B	-	-	-
SA67/T	M1	-	-	-	-	-	A	225

2.5 Nameplate information

Example

The following figure shows an example of a nameplate for a helical-worm gear unit with a NEMA C-Face adapter (AM) for a size 145TC motor.

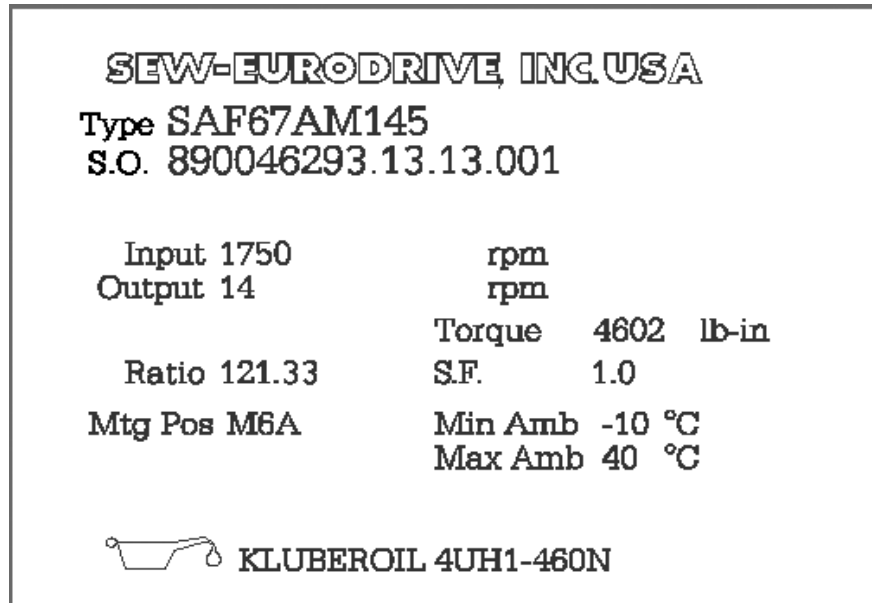

The following information is included on the nameplate:

- Type (Nomenclature)
- SO# (Sales Order / Serial Number)
- Input Speed
- Output Speed
- Ratio
- Mounting Position
- Maximum Output Torque (lb-in)
- Service Factor (S.F.)
- Minimum Ambient Temperature (°C)
- Maximum Ambient Temperature (°C)
- Oil Type

2.6 Input components

2.6.1 AD input shaft assembly

The following figure shows a helical gear unit (R-series) with AD input shaft assembly:



04583AXX

Gear units are available with a solid input shaft assembly. The diameter of the shaft is available in either inch or IEC standard metric. The end of the shaft has a center bore for mounting and attaching drive components.

The bearings on the input shaft are grease-lubricated. NBR oil seals and gap rings are used for sealing the cover. The solid output shaft bearings allows for high overhung loads.

Motor mounting platform AD../P

Belt drives are available with adjustable motor mounting platform for space-saving installation. The motor mounting platform is arranged parallel to the drive shaft. The standard plate does not contain tapped holes for the motor, but can be ordered with holes, if desired. The distance from the input shaft can be adjusted using threaded columns.

The following figure depicts a helical gear unit (R-series) with input shaft assembly and motor mounting platform AD../P:

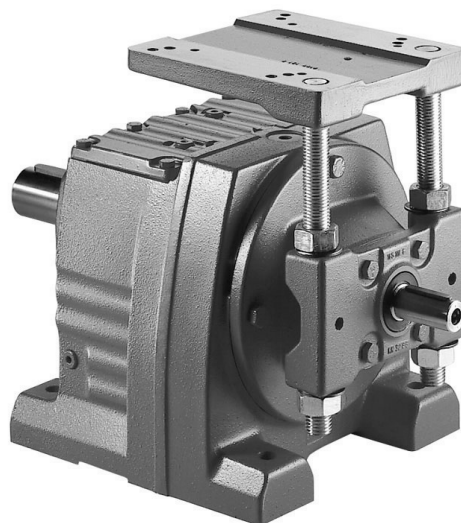

53585AXX

2.6.2 AM motor adapter - IEC or NEMA

The following figure shows a helical-worm gear unit (S-series) with AM adapter:

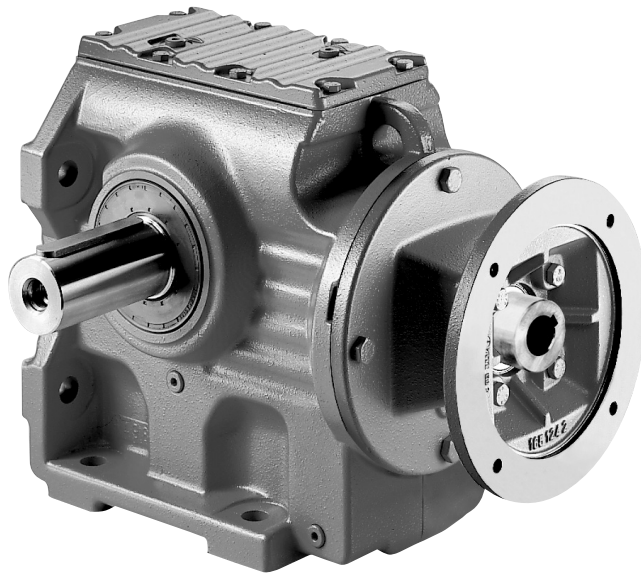

04588AXX

AM adapters are used for mounting motors to SEW gear units according to IEC standard or NEMA (type C or TC) .

Adapters are available for sizes 63 to 280 for IEC motors. Adapters are available for sizes 56 to 365 for NEMA motors. The designation of the adapter size corresponds to the respective IEC or NEMA motor size.

Torque is transmitted between the motor and the gear unit via a fail-safe jaw-type coupling. Vibrations and shock occurring during operation are effectively dampened by a polyurethane "spider" ring gear that fits between the two coupling halves, as shown below.



04589US

2.6.3 AR adapter with torque limiting coupling

The following figure shows a helical-bevel gear unit with AR adapter:



04604AXX

The torque is transmitted non-positive via friction linings. The slip torque of the coupling can be adjusted via a setting nut and cup springs. Different slip torques are possible depending on the thickness and arrangement of the cup springs. In the event of an overload, the coupling slips and interrupts the power flow between motor and gear unit, preventing damages to the system and drive.

A closeup image of the slip coupling is shown below.

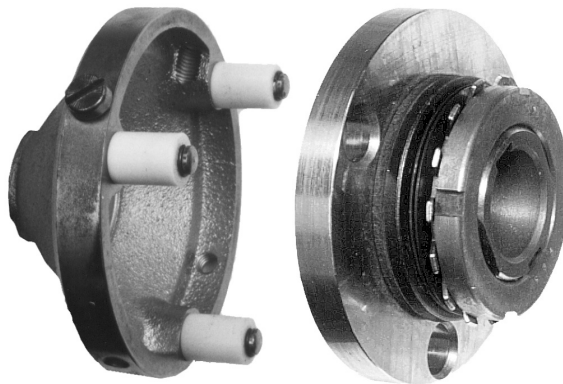

04590US

2.6.4 AT adapter with hydraulic centrifugal coupling

The following figure shows a parallel shaft gear unit (F-series) with AT adapter:



04607AXX

Gear units can be combined with adapters and hydraulic centrifugal couplings for machines with high inertia starting (e.g. mixers, agitators, etc.). The hydraulic centrifugal coupling protects the motor and the driven machine against overload during the startup phase and ensures that the machine starts up smoothly. The coupling is installed in a housing for safety. Cooling of the coupling is ensured by ventilation openings in the housing. The housing accepts SEW motor sizes 71 to 180 (0.50 to 30 HP).

Preferred motor input speeds are 1800 rpm (4-pole) or 3600 rpm (2-pole). Note that the noise level increases when using the 2-pole motor combination.

2.6.5 Swing base with hydraulic centrifugal coupling

SEW-EURODRIVE provides helical-bevel gear units with hydraulic centrifugal coupling (and brake if requested) on a swing base for motors size 200 and larger (40 to 120 HP), as shown below. The relevant dimension sheets are available on request.

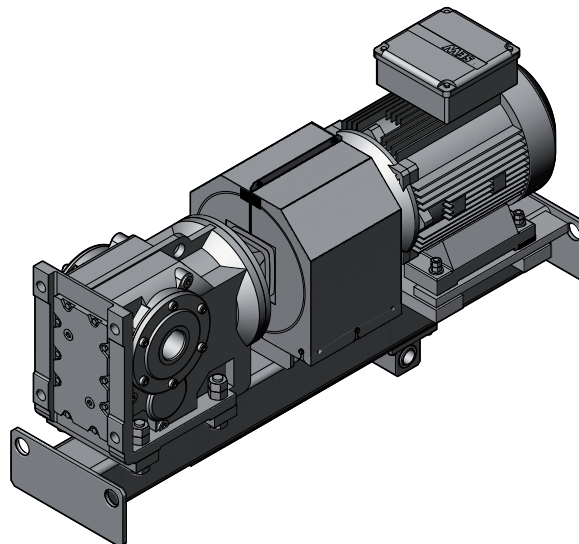

68152AXX

2.6.6 AT..BM(G) adapter with hydraulic centrifugal coupling and disc brake

The following figure shows a parallel shaft gear unit (F-series) with AT adapter and disc brake BM(G):



04611AXX

The adapter with hydraulic centrifugal coupling can be configured with an SEW disc brake if the machine needs to stop in a defined manner. The brake is an electromagnetic disc with a DC coil that is released electrically. Spring force provides the braking. As a result, it satisfies the safety requirement of braking in the event of a power failure. Upon request, the brake can be equipped with manual brake release.

The braking torque can be varied by the number and type of springs used. The brake can be supplied with DC or AC voltage connection. The connection terminals and brake rectifier are located inside a terminal box attached to the adapter.

3 Nomenclature

3.1 Overview

The nomenclature (model number) of a gear unit or gearmotor starts from the output shaft. For a gear unit, the nomenclature consists of nine fields, as shown in the two examples below. Detailed explanation of each field begins on the next page.

3

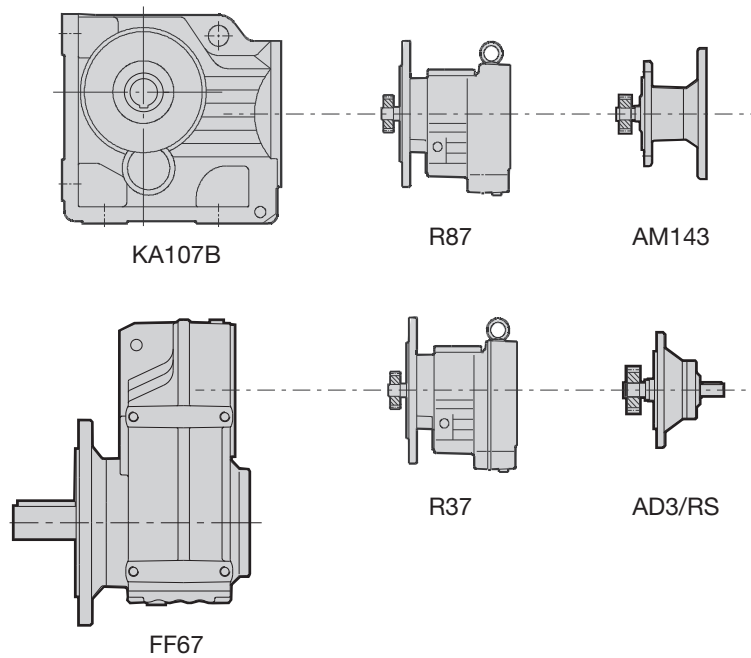

- 1
- 2
- 3
- 4
- 5
- 6
- 7
- 8
- 9

K	A	107	B	R37	AM	143	
F	F	67		R37	AD	3	/RS

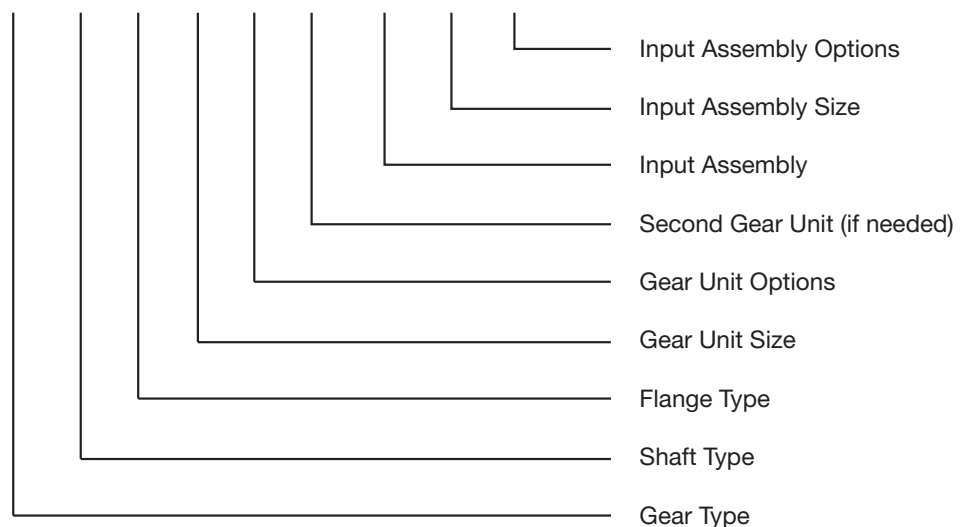

04669US

Explanation of each option field is shown below.

1 - Gear type

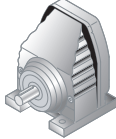
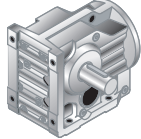
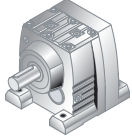
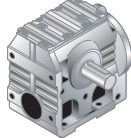
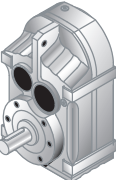
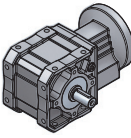
Nomenclature			Nomenclature		
RX	Helical-parallel (1 stage gearing)		K	Helical-bevel right angle	
R	Helical-parallel (2 or 3 stage)		S	Helical-worm right angle	
F	theSnuggler® Helical-parallel		W	SPIROPLAN® right angle	

2 - Shaft type

Nomenclature	
(blank)	Solid shaft with keyway
A	Hollow shaft with key
H	Hollow shaft with keyless shrink disc
V	Hollow shaft with DIN 5480 spline
T	TorqLOC® - keyless hollow shaft with tapered-bushing

3 - Flange type

Nomenclature	Description	Availability (Gear Type)				
		R	F	K	S	W
(blank)	No flange (foot mounting)	•	•	•	•	•
F	B5 flange on one side with tenon and through holes	•	•	•	•	•
F1)	B5 flange on two sides with tenon and through holes			•	•	
Z	B14 flange with tenon and tapped holes	•	•	•	•	
M	B5 flange with extended bearing housing for agitators	•				

1) For flange on both sides, specify "AB" in mounting position (ex: M1AB)

4 - Gear size

Nomenclature	Availability (Gear Type)				
	R	F	K	S	W
19 ¹⁾			•		
20 ¹⁾					•
27	•	•			
29 ¹⁾			•		
30 ¹⁾					•
37	•	•	•	•	•
39			•		
47	•	•	•	•	•
49			•		
57	•	•	•	•	
67	•	•	•	•	
77	•	•	•	•	
87	•	•	•	•	
97	•	•	•	•	
107	•	•	•		
127		•	•		
137	•				
147	•				
157		•	•		
167	•		•		
187			•		

1) Available only with integral motor

5 - Gear unit options

Nomenclature	Description	Availability (Gear Type)				
		R	F	K	S	W
/R	Reduced backlash	•	•	•		
/T	Torque arm			•	•	•
/G	Rubber buffer		•			
B	Shaft-mounted housing containing feet with through holes			•		•
B	Shaft-mount housing containing tapped holes as feet		•			

6 - Second gear unit

Nomenclature	Description
R17	Helical-inline gear unit with integral mounting flange. Adds 2 or 3 additional stages of gearing for slow speeds.
R37	
R57	
R77	
R87	
R97	
R107	

7 - Input assembly

Nomenclature	Description
AD	Input shaft assembly
AM	Adapter for mounting IEC or NEMA motors
AQA	Adapter for servo motor with keyway
AQH	Adapter for servo motor with smooth shaft (no keyway)
AR	Adapter with torque limiting slip coupling - use with standard IEC flanged motor
AT	Adapter with hydraulic centrifugal coupling

8 - Input assembly size

AD	AM		AR ¹⁾		AQA AQH	AT
	NEMA	IEC	@ Motor	Between Gear Units		
1	56	63	71	85	80	311
2	143	71	80	105	100	312
3	145	80	90	115	115/1	321
4	182	90	100	135	115/2	322
5	184	100	112	145	115/3	421
6	213/215	112	132S/M	165	140/1	422
7	254/256	132ML	132ML	185	140/2	522
8	284/286	132S/M	160	195	140/3	541
	324/326	160	180		190/1	542
	364/365	180			190/2	
		200			190/3	
		225				
		250				
		280				

¹⁾ AR adapter may be placed between the gear units (on compound units) or between the gear unit and motor.

9 - Input assembly options

Nomenclature	Description	Availability (Gear Type)				
		AD	AM	AQ	AR	AT
/RS	Backstop	•	•			•
/P	Motor mounting platform	•				
/W	Speed monitor				•	
/ZR	Machined centering shoulder	•				
/ZS	Mounting scoop for footed motor	•				
/BM(G)	Disc brake					•
/BM(G)/HF	Disc brake w/ screw release					•
/BM(G)/HR	Disc brake w/ lever release					•

3.2 Shaft and flange combinations

Helical gear units

The following illustrations detail the shaft/flange combinations for R-series helical gear units.

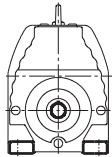
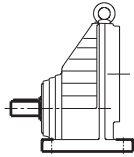

RX..
Foot-mounted (single-stage gearing)

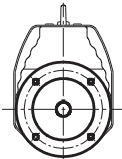
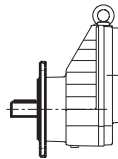

RXF..
B5 flange-mounted (single-stage gearing)

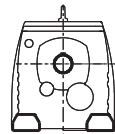
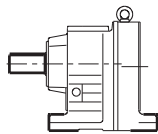

R..
Foot-mounted

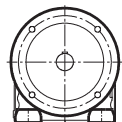
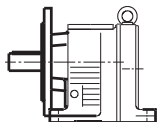

R..F
Foot + B5-flange mounted

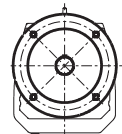
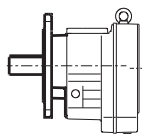

RF..
B5 flange-mounted

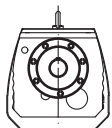
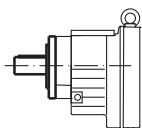

RZ..
B14 flange-mounted

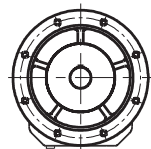
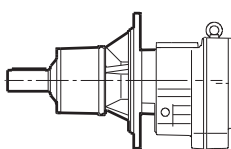

RM..
B5 flange-mounted + extended bearing housing

63665axx

theSnuggler® - Parallel shaft helical gear units

The following illustrations detail the shaft/flange combinations for theSnuggler® F-series parallel shaft helical gear units.

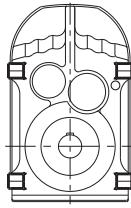
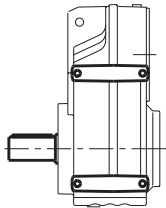

F..
Foot-mounted (tapped holes)

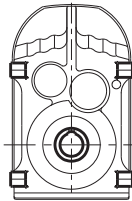
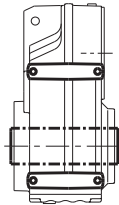

FA..B
Foot-mounted (tapped holes) + hollow shaft with key

FV..B
Foot-mounted (tapped holes) + hollow shaft with DIN 5480 spline

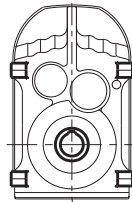
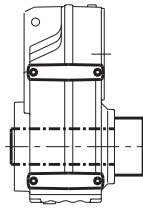

FH..B
Foot-mounted (tapped holes) + keyless shrink disc

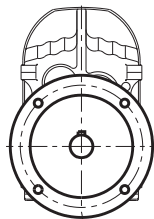
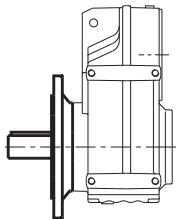

FF..
B5 flange-mounted

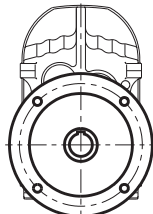
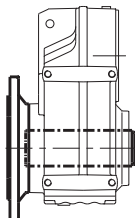

FAF..
B5 flange-mounted + hollow shaft with key

FVF..
B5 flange-mounted + hollow shaft with DIN 5480 spline

52182axx

3 Nomenclature

Shaft and flange combinations

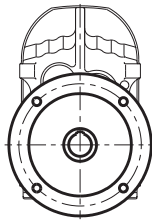
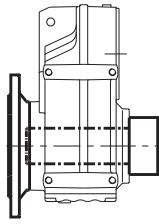

FHF..
B5 flange-mounted + hollow shaft with keyless shrink disc

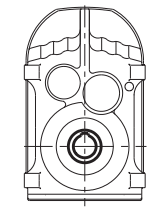
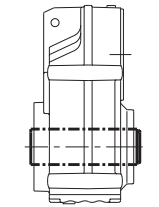

FTF..
B5 flange-mounted + hollow shaft with TorqLOC® keyless tapered-bushing system

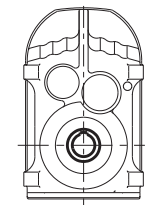
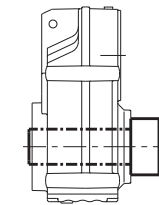

FA..
Hollow shaft with key

FV..
Hollow shaft with DIN 5480 spline

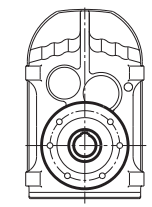
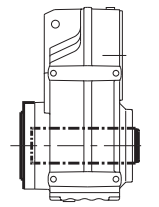

FH..
Hollow shaft with keyless shrink disc

FT..
Hollow shaft with TorqLOC® keyless tapered-bushing system

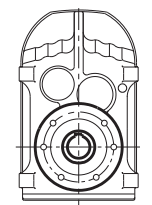
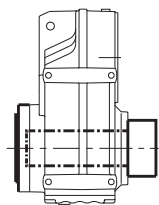

FAZ..
B14 flange-mounted + hollow shaft with key

FVZ..
B14 flange-mounted + hollow shaft with DIN 5480 spline



FHZ..
B14 flange-mounted + hollow shaft with keyless shrink disc

52184axx

Helical-bevel gear units

The following illustrations detail the shaft/flange combinations for K-series helical-bevel gear units.

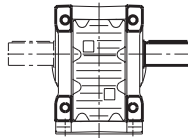
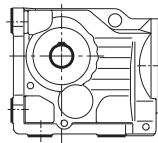

K..
Foot-mounted

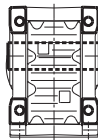
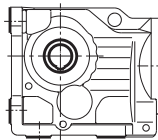

KA..B
Foot-mounted + hollow shaft with key

KV..B
Foot-mounted + hollow shaft with DIN 5480 spline

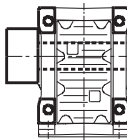
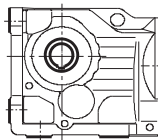

KH..B
Foot-mounted + hollow shaft with keyless shrink disc

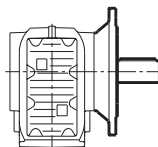
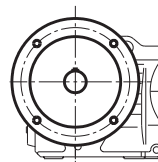

KF..
B5 flange-mounted

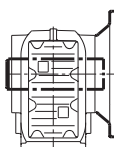
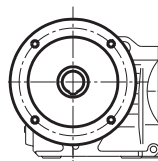

KAF.
B5 flange-mounted + hollow shaft with key

KVF.
B5 flange-mounted + hollow shaft with DIN 5480 spline

52186axx

3 Nomenclature

Shaft and flange combinations

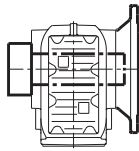
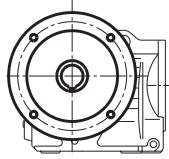

KHF..
B5 flange-mounted + hollow shaft with keyless shrink disc

KTF..
B5 flange-mounted + hollow shaft with TorqLOC® keyless tapered-bushing system

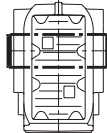
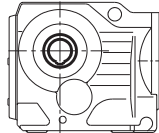

KA..
Hollow shaft with key

KV..
Hollow shaft with DIN 5480 spline

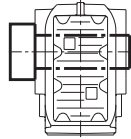
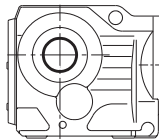

KH..
Hollow shaft with keyless shrink disc

KT..
Hollow shaft with TorqLOC® keyless tapered-bushing system

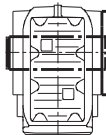
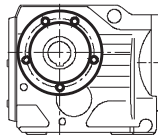

KAZ..
B14 flange-mounted + hollow shaft with key

KVZ..
B14 flange-mounted + hollow shaft with DIN 5480 spline

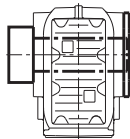
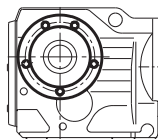

KHZ..
B14 flange-mounted + hollow shaft with keyless shrink disc

52187axx

Helical-worm gear units

The following illustrations detail the shaft/flange combinations for S-series helical-worm gear units.

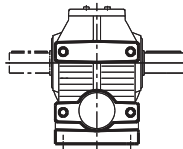
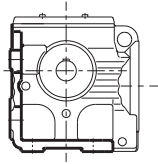

S..
Foot-mounted

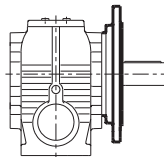
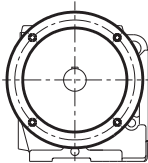

SF..
B5 flange-mounted

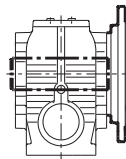
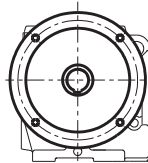

SAF..
B5 flange-mounted + hollow shaft with key

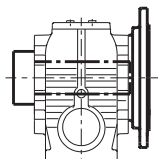
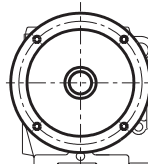

SHF..
B5 flange-mounted + hollow shaft with keyless shrink disc

STF..
B5 flange-mounted + hollow shaft with TorqLOC® keyless tapered-bushing system

52188axx

3 Nomenclature

Shaft and flange combinations

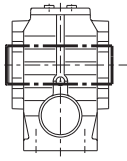
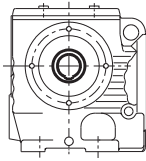

SA..
Hollow shaft with key

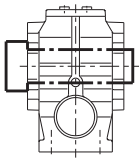
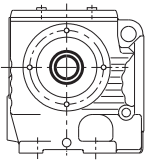

SH..
Hollow shaft with keyless shrink disc

ST..
Hollow shaft with TorqLOC® keyless tapered-bushing system

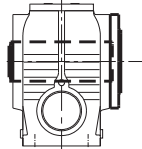
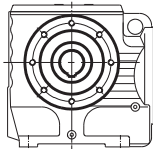

SAZ..
B14 flange-mounted + hollow shaft with key

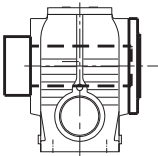
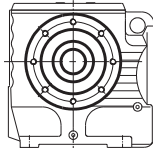

SHZ..
B14 flange-mounted + hollow shaft and keyless shrink disc

52189axx

SPIROPLAN® gear units

The following illustrations detail the shaft/flange combinations for W-series SPIROPLAN® gear units.

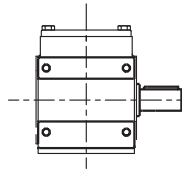
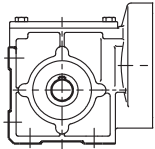

W..
Foot-mounted

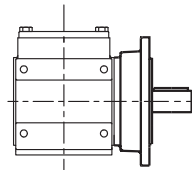
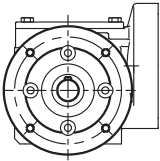

WF..
Flange-mounted

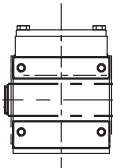
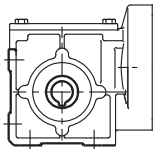

WA..
Hollow shaft with key

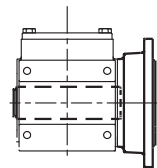
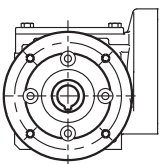

WAF..
Flange-mounted + hollow shaft with key

63666axx

3 Nomenclature

Shaft and flange combinations

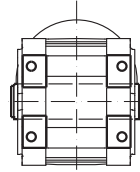
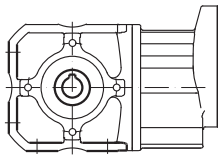

WA..B
Foot-mounted + hollow shaft with key

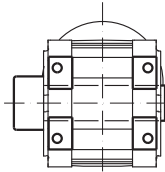
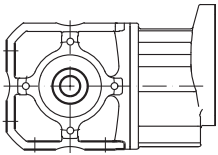

WH..B
Foot-mounted + hollow shaft with keyless shrink disc

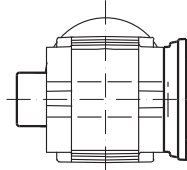
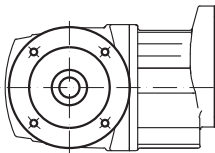

WHF..
Flange-mounted + hollow shaft with keyless shrink disc

WTF..
B5 flange-mounted + hollow shaft with TorqLOC® keyless tapered-bushing system

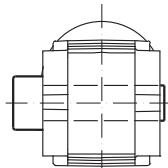
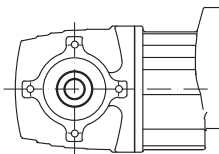

WH..
Hollow shaft with keyless shrink disc

WT..
Hollow shaft with TorqLOC® keyless tapered-bushing system

63667axx

3.3 Input assemblies

The following figure shows the available input components:

65735AUS

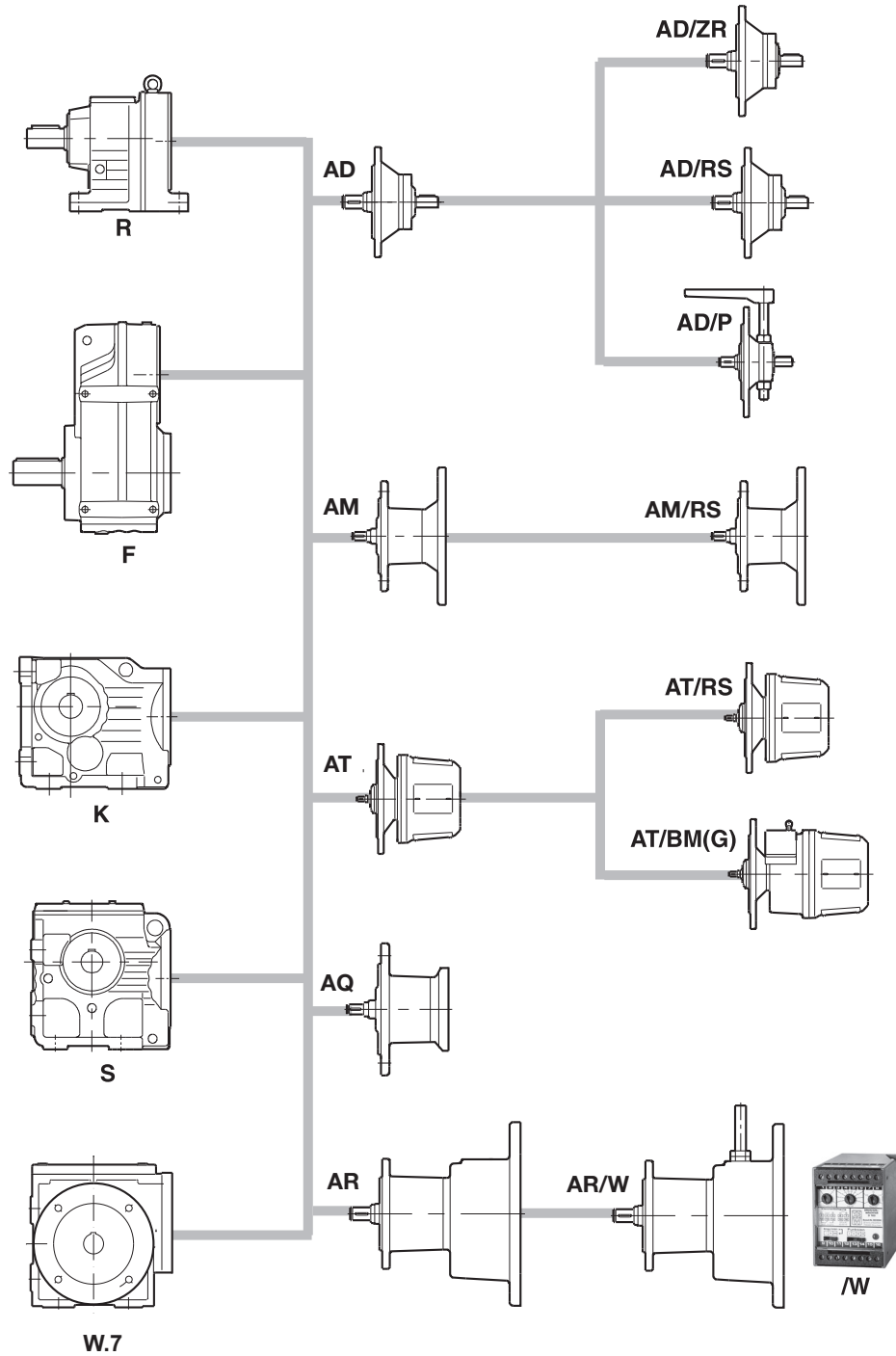

3

4 Project Planning

Project planning should be performed for all gear units. The data specified in this catalog applies only if project planning was completed correctly. It is particularly important for gear units under the following conditions:

- Increased ambient temperatures
- Altitudes > 3280 feet (less convection)
- Gear units > size 87 with small ratios (more heat from oil churning)
- All helical-worm gear units with small ratios and increased ambient temperature

4.1 List of application variables

Your application data is required in order to precisely define the correct drive. The abbreviations used for project planning are summarized in the following table:

Designation	Meaning	Unit
n_{amin}	Minimum output speed	[rpm]
n_{amax}	Maximum output speed	[rpm]
P_a at n_{amin}	Output power at minimum output speed	[HP]
P_a at n_{amax}	Output power at maximum output speed	[HP]
T_a at n_{amin}	Output torque at minimum output speed	[lb-in]
T_a at n_{amax}	Output torque at maximum output speed	[lb-in]
F_{Ra}	Overhung load on gear unit output shaft	[lb]
F_{Aa}	Axial load on gear unit output shaft	[lb]
n_e	Input speed	[rpm]
P_m at n_e	Motor input power	[HP]
T_e at n_e	Input torque	[lb-in]
$T_{e max}$	Maximum input torque	[lb-in]
F_{Re}	Overhung load on input of gear unit	[lb]
F_{Ae}	Axial load on input of gear unit	[lb]
J_{Last}	Mass moment of inertia to be driven	[lb-ft ²]
R, F, K, S, W M1 - M6	Required gear unit type and mounting position (see chapter, "Mounting positions")	-
IP..	Required degree of protection	-
ϑ_{Umg}	Ambient temperature	[°C]
H	Installation altitude	[ft above sea level]
S.., ..% cdf	Duty type and cyclic duration factor (cdf) or exact load cycle can be specified.	-
Z	Starting frequency; alternatively, exact load cycle can be specified	[1/h]
V_{Bremse}	Operating voltage of the brake (AT with brake)	[V]
T_B	Required braking torque (AT with brake)	[lb-in]
T_R	Slip torque (AR)	[lb-in]
Type of the motors	... Electric motor ... Internal combustion engine ... Hydraulic motor	-

4.2 Project planning assistance

SEW-EURODRIVE's regional engineers will gladly perform project planning for you. In addition, we offer the information in this catalog and complete documentation covering the topic of drive engineering. The publication "Project Planning for Drives" provides a comprehensive collection of the the most important formulas needed for drive calculation, as well as detailed examples for the most frequently used applications. No doubt, it is a very valuable tool for project planning!

You may download "Project Planning for Drives" by scanning the bar code below. Or, you may go to the following link: www.seweurodrive.com/download/pdf/10522913.pdf



The following catalogs are also available from SEW-EURODRIVE for assistance with project planning:

- DRE.. Gearmotors (IE2 efficiency)
- DRP.. and DRN.. Gearmotors (IE3 efficiency)
- Synchronous servo gearmotors
- X series Industrial Gear Units

You may request a hard copy of these catalogs by calling SEW-EURODRIVE, or download them from www.seweurodrive.com.

	<p>INFORMATION</p>	
	<p>Online assistance for conveyor, hoisting, and travel drive applications is available through SEW-EURODRIVE's exclusive PT Pilot® calculator.</p> <p>Simply enter your drive parameters and let PT Pilot® do all of the work. Visit www.ptpilot.com.</p>	

4.3 Selection procedure

The following flowchart presents a schematic view of the procedure for planning a project incorporating a gear unit with a component on the input side.

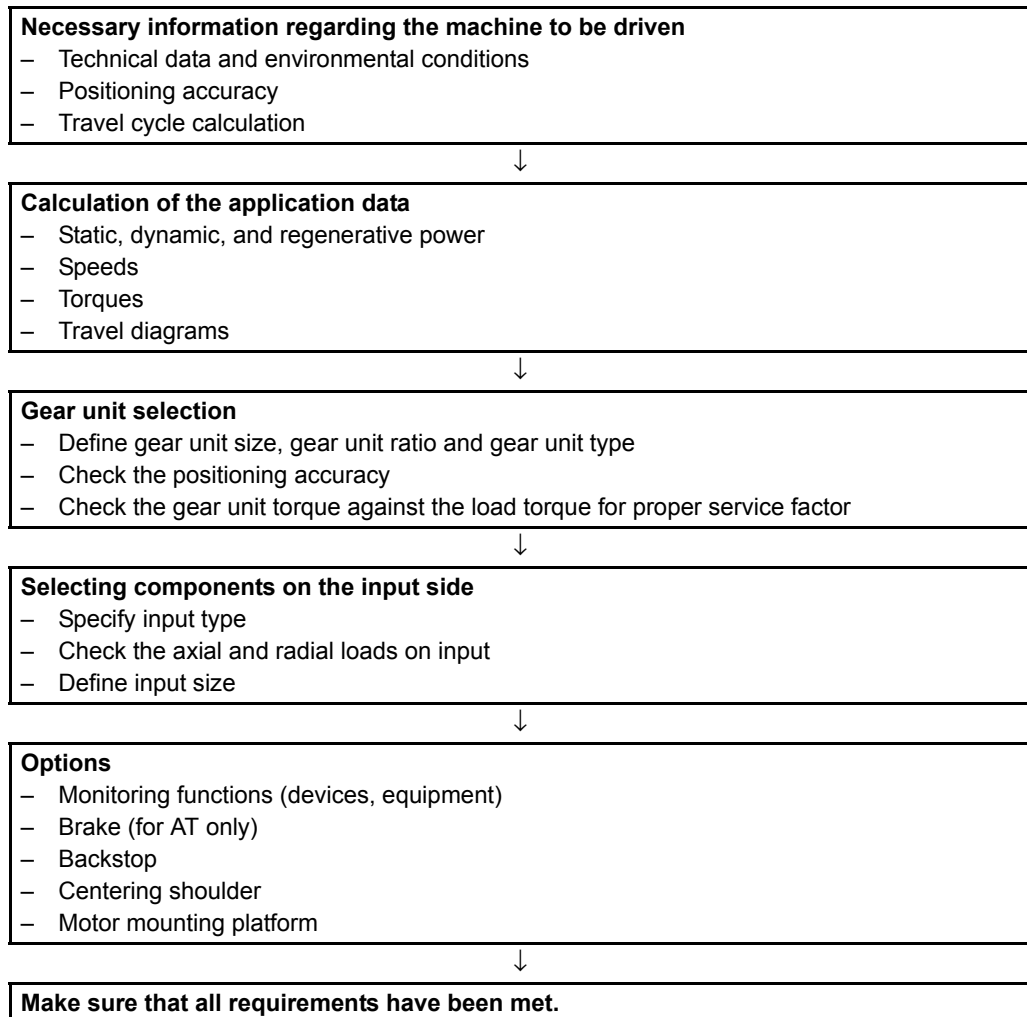

4.4 Gear efficiency and thermal losses

The efficiency of gear units is mainly determined by the gearing and bearing friction. The starting efficiency of a gear unit is always less than its efficiency at operating speed. This is particularly true for helical-worm and SPIROPLAN® right-angle gear units. Gear units are listed below in order of highest efficiency to lowest efficiency.

R, F, and K

The helical (R), parallel shaft (F) and helical-bevel (K) gear units (excluding K19, K29, K39, K49) contain 100% rolling friction and the highest efficiency. Efficiency depends on the number of gear stages: 96% (3-stage), 97% (2-stage) and 98% (1-stage).

K..19 - K..49

These right-angle units contain 2-stage hypoid gearing that combines rolling friction with minor sliding friction. Their efficiency ranges from 90% to 96%, depending on the ratio. Current sizes include K19, K29, K39, and K49.

W - SPIROPLAN®

The SPIROPLAN® gear units (W-series) combine rolling friction with some sliding friction, similar to hypoid gearing. The sliding friction induces some loss and lower efficiency than R, F or K gear units, but higher efficiency than a helical-worm (S-series).

The SPIROPLAN® gear units W37 and W47 contain a helical input stage. Therefore, they have the highest efficiency of the SPIROPLAN® gear units (>90%), dropping only slightly for larger ratios.

The efficiency depends on the following factors:

- Gear ratio
- Input speed
- Ambient temperature

S-series

The helical-worm (S-series) gear units contain a first stage helical gear set and a second stage worm set. Various degrees of sliding friction occurs in the worm set, depending on the number of starts on the worm gear. Therefore, these gear units have higher losses and lower efficiency than other SEW-EURODRIVE gear units. However, they are still significantly more efficient than single stage worm gear units common in the industry.

The efficiency depends on the following factors:

- Gear ratio (number of starts on worm)
- Input speed
- Ambient temperature

Self-locking

Backdriving torques on helical-worm or SPIROPLAN® gear units produce an efficiency of $\eta' = 2 - 1/\eta$, which is significantly less than the forward efficiency, η . The helical-worm or SPIROPLAN® gear unit is self-locking if the forward efficiency is $\eta \leq 0.5$, which may occur on some higher ratios. Therefore, some SPIROPLAN® gear units are dynamically self-locking.

Contact SEW-EURODRIVE if you wish to make technical use of the braking effect of self-locking characteristics.



INFORMATION

Note that the self-locking effect of helical-worm and SPIROPLAN® gear units should not be used as the sole safety function for hoists!

Run-in phase

When gears are initially manufactured, the tooth flanks of helical-worm and SPIROPLAN® gear units are not 100% smooth. They require a run-in period in order to achieve their maximum polish. Therefore, there is a greater friction angle and less efficiency during initial operation. This effect intensifies with higher gear ratios. To determine the startup efficiency, subtract the following values from the listed efficiency:

	Helical-Worm	
	Ratio Range	η reduction
1-start	approx. 50 ... 280	approx. 12 %
2-start	approx. 20 ... 75	approx. 6 %
3-start	approx. 20 ... 90	approx. 3 %
5-start	approx. 6 ... 25	approx. 3 %
6-start	approx. 7 ... 25	approx. 2 %

Ratio Range	SPIROPLAN® W..
	η reduction
approx. 30 ... 75	approx. 8 %
approx. 10 ... 30	approx. 5 %
approx. 3 ... 10	approx. 3 %

The run-in period usually lasts 48 hours. Helical-worm and SPIROPLAN® gear units achieve their rated efficiency under the following conditions:

- The gear unit has completed the run-in period
- The gear unit has reached nominal operating temperature
- The gear unit contains the recommended lubricant and fill quantity
- The gear unit is operating in the rated load range

Thermal losses

In certain gear unit mounting positions (see chapter "Mounting Positions"), the first gearing stage is completely immersed in the lubricant. When the circumferential velocity of the input stage is high, considerable churning losses occur, especially in larger gear units (> size 87), or with input speeds > 1750 rpm. As a result, the gear unit may have a reduced input HP rating. Substituting synthetic oil and high temperature FKM seals often permits a higher operating temperature and increases the HP rating.

To keep churning losses to a minimum, use gear units in M1 mounting position whenever possible. For more information on gear units with AD input shaft assembly, see page 63.



INFORMATION

For thermal limitations, you may visit www.ptpilot.com. PT Pilot® uses average conduction and convection to figure your thermal limitation. It also provides a complete quotation, including all motor and gear unit options.

4.5 Service factor and inertia

Inertia acceleration factor

The inertia acceleration factor, IAF, is the ratio between the system (load) inertias and the motor inertias. It is an important factor that determines system stability and gear unit service factor. It is calculated at the motor shaft, as follows:

$$IAF = \frac{J_{gear} + J_{apt} + J_x}{J_{mot} + J_b + J_z}$$

- J_x = Inertia of all load components reflected to the motor shaft
- J_{gear} = Inertia of gear unit (ratio dependent)
- J_{apt} = Inertia of input adapter (AD, AM, AT, AQ)
- J_{mot} = Inertia of motor without brake
- J_b = Inertia of the brake on motor shaft (if applicable)
- J_z = Inertia of the cast iron fan on motor (if applicable)

Values for J_{mot} and J_z are available in the motor section of SEW catalogs. J_b is already included in the value for J_{mot} if you select the column for brakemotor. Both J_{gear} and J_{apt} are often negligible, especially on smaller gear units.

J_x can be calculated from the application formulas below.

Linear Motion (Conveyor, Travel Drive, Hoist)	Rotational Motion (Turntable, Solid Cylinder)
$J_x = \frac{W_T}{39.5} \times \left\{ \frac{V_{max}}{n_m} \right\}^2$	$J_x = \frac{W_T}{2} \times \left\{ \frac{D}{24} \right\}^2 \times \left\{ \frac{n_t}{n_m} \right\}^2$

- W_T = Total weight (lbs)
- V_{max} = Maximum velocity (feet per minute)
- D = Diameter of turntable or cylinder (in)
- n_t = Turntable speed (rpm)
- n_m = Motor full-load speed (rpm)

Load classification

There are three load classifications, based upon the inertia acceleration factor:

Load Class	Type	IAF
(I)	Uniform	$IAF \leq 0.2$
(II)	Moderate Shock	$0.2 < IAF \leq 3.0$
(III)	Heavy Shock	$3.0 < IAF \leq 10$

Contact SEW-EURODRIVE for inertia acceleration factor > 10.

SEW service factor, f_B

The load from the driven machine imposes a shock on the gear unit. The degree of shock depends upon the load inertia, motor inertia, daily operating time, and starting frequency. The SEW service factor, f_B , considers all of these variables.

Since the method for determining the maximum output torque rating can vary among gear manufacturers, the required SEW service factor applies to SEW gear units. As such, this service factor may differ from an AGMA service factor, or the service factor from another manufacturer. However, even when $f_B=1.0$, the SEW gear unit contains an extremely high level of safety and reliability in the fatigue strength range.

Service factor is determined from Figure 1 below, using the load classifications I, II, III as defined on page 46. For proper project planning, the maximum permissible output torque of the gear unit (as shown in the selection tables within this catalog) must be greater than the load torque multiplied by the SEW service factor, f_B , per the following equation.

$$T_{amax} \geq (T_a \times f_B)$$

T_a = load torque

T_{amax} = maximum permissible output torque (from gear unit tables)

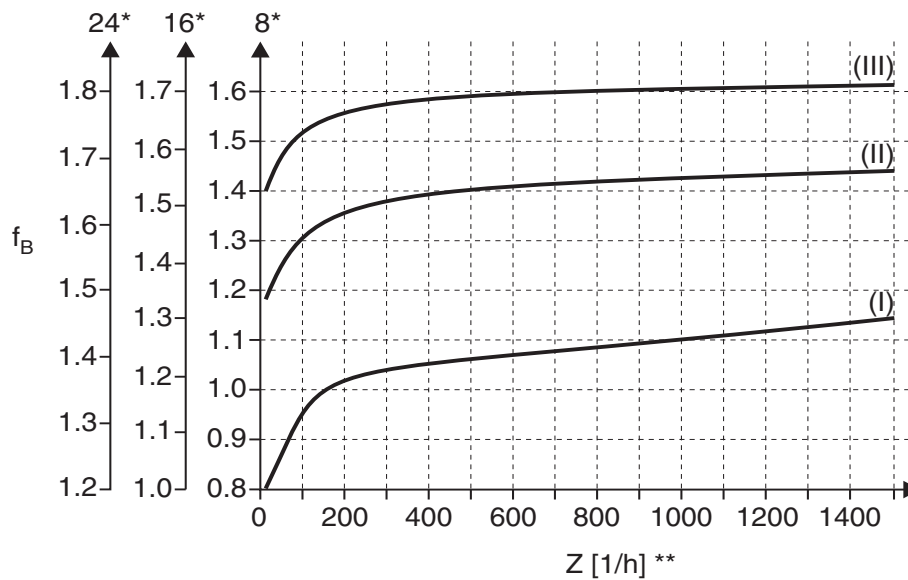

00656BXX

Figure 1: SEW service factor f_B

* Daily operating time in hours/day

** Frequency, Z, is the sum of all load changes within one hour, which includes all instances of starting, braking, and speed changes. Example: In one hour, a 2-speed motor starts 50 times, switches from low to high speed 50 times, switches from high to low speed 50 times, and stops 50 times. In this case, Z= 200.

$f_B > 1.8$ can occur with large inertia acceleration factor (>10), high levels of backlash in the transmission elements, or a large overhung load. Contact SEW-EURODRIVE.

Example 1

- Inertia acceleration factor = 2.5
- 14 hours/day operation
- 300 load changes/hour
- R, F, or K-series gear unit required

Using the load classification table: when IAF = 2.5 then,
Load class = II.

From Figure 1: Using the column for 16 hr/day (round up 14 hrs/day) and load class II,
 $f_B = 1.5$.

Therefore, the R, F, or K gear unit must have torque rating,
 $T_{amax} > (\text{load torque} \times 1.5)$

**Helical-worm
(S-series)**

For helical-worm (S-series), two additional service factors, f_{B1} and f_{B2} , are needed and obtained from Figure 2 below. Contact SEW-EURODRIVE if the temperature $< -20^{\circ}\text{C}$ [-4°F].

- f_{B1} = Service factor from ambient temperature
- f_{B2} = Service factor based upon %ED, which is the amount of time the motor is operating compared to the time that it is resting.

$$\%ED = \frac{\text{Time under load in min/hr}}{60} \times 100$$

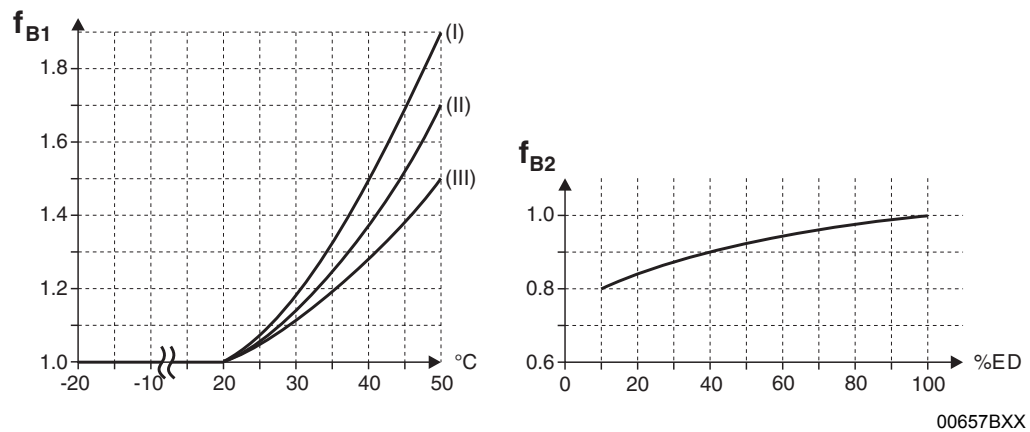

Figure 2: Additional service factors f_{B1} and f_{B2}

The total service factor for a helical-worm gear unit becomes:

$$f_{B\text{total}} = f_B \times f_{B1} \times f_{B2}$$

Example 2 Change example 1 to use a helical-worm gear unit with the additional conditions below.

- Inertia acceleration factor = 2.5 (load class = II)
- 14 hours/day operation
- 300 load changes/hour
- Ambient temperature = 40°C
- Time under load = 40 min/hour
- Load Torque = 4200 lb-in
- 29:1 ratio

From Figure 1 using 16 hr/day,

$$f_B = 1.50$$

Calculate %ED,

$$ED = 40/60 = 66.7\%$$

Using Figure 2,

$$f_{B1} = 1.40$$

$$f_{B2} = 0.95$$

The total service factor becomes,

$$f_{Btotal} = 1.50 \times 1.40 \times 0.95 = 2.0$$

Therefore, the helical-worm gear unit must have an output torque rating,

$$T_{amax} > (4200 \text{ lb-in} \times 2.0)$$

$$T_{amax} > 8400 \text{ lb-in}$$

From the S67 gear unit table on page 582, $T_{amax} = 4240 \text{ lb-in}$, which is too low.

Thus, the solution requires an S77, 28.41:1, $T_{amax} = 8750 \text{ lb-in}$, as shown on page 584.

4.6 Axial forces and overhung loads

Axial force

If there is no overhung load, then an axial force. F_A (tension or compression) equal to **50%** of the overhung load given in the selection tables is permitted on the output shaft. The 50% rule applies to the following gear units:

- R-series helical gearmotors except R..137... to R..167...
- F-series parallel shaft with solid shaft except F97...
- K-series helical-bevel with solid shaft
- S-series helical-worm gear units with solid shaft

4



INFORMATION

Contact SEW-EURODRIVE for all other types of gear units, a greater axial load, or a combination of an overhung load and an axial load.

Overhung load (OHL)

The type of transmission component that is mounted to the output shaft has a direct impact on the overhung load. Some components impart higher forces than others, as shown by the transmission factor, f_z in the following table.

Component	Transmission factor f_z	Comments
Gears	1.15	< 17 teeth
Chain sprockets	1.40	< 13 teeth
Chain sprockets	1.25	< 20 teeth
Narrow V-belt pulleys	1.75	Due to pre-tension
Flat belt pulleys	2.50	Due to pre-tension
Timing or toothed belt pulleys	2.00 - 2.50	Due to pre-tension
Gear rack pinion, pre-tensioned	2.00	Due to pre-tension

The following formula determines the overhung load on the output shaft of a gear unit.

$$F_R = \frac{2 \times T}{d_0} \times f_z$$

F_R = Overhung load (lbs)

T = Load torque (lb-in)

d_0 = Diameter of the gear, sprocket, or pulley (in inches)

f_z = Transmission factor

Permissible OHL

The basis for determining the permissible overhung loads is the calculation of the rated bearing service life L_{10h} of the rolling bearings (according to ISO 281).

The overhung load rating changes for every angle, α , and direction of rotation. Since the rating listed in the catalog is based upon the most unfavorable angle and direction, a higher overhung load rating is possible when considering your specific angle and rotation. In addition, even higher loads are permitted if heavy duty bearings are installed on the output shaft of R, F, and K gear units. Contact SEW-EURODRIVE in such cases. Use the figure below to specify your angle of force.

The application force, is defined according to the following figure:

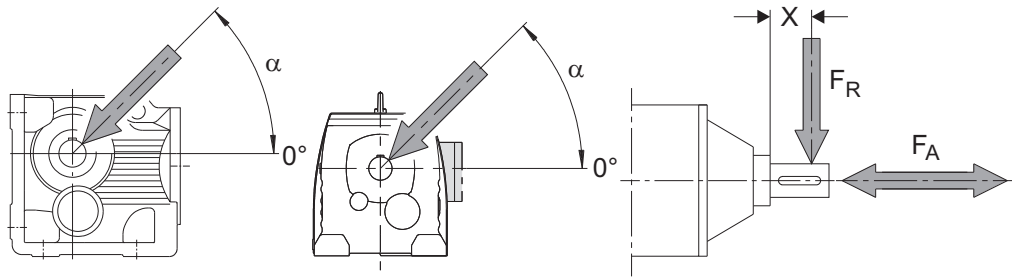



63214axx

α = angle of force

F_R = Permissible overhung load at distance, x [lbs]

F_A = Permissible axial load [lbs]

INFORMATION	
	<p>The overhung load values (F_{Ra}) shown in the rating tables of this catalog refer to a force applied at the center of a standard-length solid output shaft. These values are also based upon the most unfavorable application angle, α, and direction of rotation.</p> <p>For OHL values of a hollow shaft gear unit, please consult SEW-EURODRIVE.</p>

INFORMATION	
	<p>Reduction of overhung loads</p> <ul style="list-style-type: none"> • Only 50% of the F_{Ra} value specified in the selection tables is permitted in mounting position M1 with wall attachment on the front face for K and S gear units. • Helical-bevel gearmotors K167 and K187 in mounting positions M1 to M4: A maximum of 50% of the overhung load F_{Ra} specified in the selection tables in the case of gear unit mounting other than as shown in the mounting position sheets. • Foot and flange-mounted helical gearmotors (R..F): A maximum of 50% of the overhung load F_{Ra} specified in the selection tables in the case of torque transmission via the flange mounting.

OHL conversion

Please contact SEW-EURODRIVE to determine the permissible overhung load for an input shaft assembly (ex: R67AD2) when the overhung load force is not located at the center of the input shaft.

When the overhung load force is not applied at the midpoint of the output shaft, the following formulas should be used to determine two permissible overhung load values - F_{xL} for bearing life, and F_{xW} for shaft strength. The constants in the formulas are listed on the next page for each gear unit size.

The final permissible value, F_R , for the overhung load at point, x , is the smaller of the two values of F_{xL} and F_{xW} .

F_{xL} , based on bearing life:

$$F_{xL} = F_{Ra} \times \frac{a}{b + x} \quad [\text{lb}]$$

F_{xW} , based upon shaft strength:

$$F_{xW} = \frac{c \times 10^3}{f + x} \quad [\text{lb}]$$

- F_{Ra} = Permitted overhung load [lb] at the midpoint ($x = l/2$) of the output shaft for foot-mounted gear unit. See selection tables.
- x = Distance from the shaft shoulder to the point of application [in]
- a, b, f = Gear unit constants for overhung load conversion [in]
- c = Gear unit constant for overhung load conversion [lb-in]

Figure 3 shows the overhung load F_R not located at the shaft mid-point:

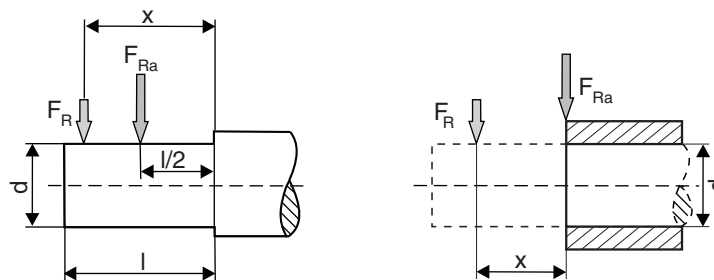

63215axx

Figure 3: Overhung load, F_R not located at shaft midpoint

4 Project Planning

Axial forces and overhung loads

Constants for
overhung load
conversion

Gear unit type	a [in]	b [in]	c [lb-in]	f [in]	d [in]	l [in]
RX/RXF57	1.71	0.93	1.34	1.35	0.750	1.57
RX/RXF67	2.07	1.08	2.14	1.56	1.000	1.97
RX/RXF77	2.38	1.20	1.73	0	1.250	2.36
RX/RXF87	2.89	1.32	6.81	1.93	1.625	3.15
RX/RXF97	3.41	1.44	12.66	2.12	2.125	3.94
RX/RXF107	4.04	1.67	21.86	2.45	2.375	4.72
R/RF07	2.83	2.05	0.41	0.43	0.750	1.57
R/RF17	3.48	2.70	0.58	0.67	0.750	1.57
R/RF27	4.19	3.21	1.38	0.46	1.000	1.97
R/RF37	4.65	3.66	1.10	0	1.000	1.97
R/RF47	5.39	4.21	2.16	0.59	1.250	2.36
R/RF57	5.81	4.43	3.34	0.71	1.375	2.76
R/RF67	6.63	5.26	2.35	0	1.375	2.76
R/RF77	6.84	5.26	3.51	0	1.625	3.15
R/RF87	8.53	6.56	7.50	0	2.125	3.94
R/RF97	10.06	7.70	10.53	0	2.375	4.72
R/RF107	11.24	8.48	18.23	0	2.875	5.51
R/RF137	13.52	10.18	54.34	1.18	3.625	6.69
R/RF147	15.83	11.69	76.56	1.30	4.375	8.27
R/RF167	17.72	13.58	111.52	0	4.750	8.27
F27	4.31	3.33	1.00	0	1.000	1.97
F37	4.86	3.88	0.95	0	1.000	1.97
F47	6.04	4.86	1.58	0	1.250	2.36
F57	6.72	5.34	4.86	1.26	1.375	2.76
F67	7.14	5.56	3.65	0	1.625	3.15
F77	8.50	6.53	6.97	0	2.000	3.94
F87	10.35	7.99	10.53	0	2.375	4.72
F97	13.78	11.02	18.50	0	2.875	5.51
F107	14.70	11.36	37.44	0	3.625	6.69
F127	17.42	13.29	83.64	0	4.375	8.27
F157	20.16	16.02	92.93	0	4.750	8.27
K37	4.86	3.88	1.25	0	1.000	1.97
K47	6.04	4.86	1.58	0	1.250	2.36
K57	6.68	5.30	6.02	1.22	1.375	2.76
K67	7.14	5.56	3.65	0	1.625	3.15
K77	8.50	6.53	6.81	0	2.000	3.94
K87	9.92	7.56	14.52	0	2.375	4.72
K97	12.56	9.80	24.78	0	2.875	5.51
K107	14.70	11.36	48.94	0	3.325	6.69
K127	17.46	13.33	73.55	0	4.375	8.27
K157	20.04	15.91	104.44	0	4.750	8.27
K167	24.47	19.55	166.39	0	6.250	9.84
K187	28.37	22.07	269.06	0	7.500	12.60
W10	3.34	2.55	0.32	0	0.625	1.57
W20	3.88	3.09	0.39	0	0.750	1.57
W30	4.31	3.52	0.53	0	0.750	1.57
W37	4.77	3.98	0.61	0	0.787	1.57
W47	5.73	4.55	3.74	1.40	1.181	2.36
S37	4.67	3.88	0.53	0	0.750	1.57
S47	5.12	4.13	1.18	0	1.000	1.97
S57	5.91	4.72	1.89	0	1.250	2.36
S67	7.24	5.87	2.69	0	1.375	2.76
S77	8.82	7.05	4.66	0	1.750	3.54
S87	11.08	8.72	14.87	0	2.375	4.72
S97	12.85	10.09	22.48	0	2.875	5.51

d = standard diameter of output shaft [in]

l = standard length of output shaft [in]

Values for gear unit types not listed are available on request.

4.7 AM adapter with IEC/NEMA motor

Power ratings,
mass moments of
inertia

Type (IEC)	Type (NEMA)	$P_m^{1)}$ [HP]	J_{apt} [lb-ft ²]
AM63	-	0.33	1.05×10^{-3}
AM71	AM56	0.50	1.05×10^{-3}
AM80	AM143	1.0	4.51×10^{-3}
AM90	AM145	2.0	4.51×10^{-3}
AM100	AM182	4.0	12.34×10^{-3}
AM112	AM184	5.4	12.34×10^{-3}
AM132S/M	AM213/215	10	45.1×10^{-3}
AM132ML	-	12.5	45.1×10^{-3}
AM160	AM254/256	20	216×10^{-3}
AM180	AM284/286	30	214×10^{-3}
AM200	AM324/326	40	413×10^{-3}
AM225	AM364/365	60	413×10^{-3}
AM250	-	75	411×10^{-3}
AM280	-	125	1626×10^{-3}

1) Maximum rated power of the mounted electric motor at 1750 rpm

Selecting the gear unit

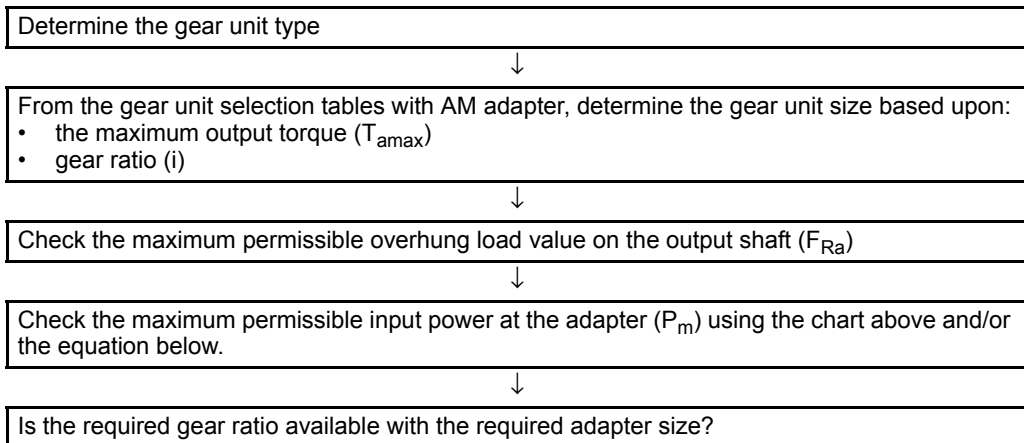

Input power (P_m) at alternate speed

The maximum input power (P_m) shown in this catalog corresponds to 1750 rpm. For input speeds other than 1750, use the formula below to calculate the maximum input power.

$$P_{new} = P_m \times \frac{RPM_{new}}{1750}$$

**Backstop
AM../RS**

If the application requires only one direction of rotation, the AM adapter can be configured with a backstop. Backstops with centrifugal lift-off sprags are used. The advantage of this design is that above a certain speed (lift-off speed), the sprags move around inside the backstop without making contact. Therefore, the backstop is suited for high speeds and operates maintenance free, wear-free, and without losses.

Dimensions:

The backstop is completely integrated inside the adapter. Therefore, the dimensions are the same with or without backstop.

Locking torques:

Type	Maximum locking torque of the backstop [lb-in]	Minimum lift-off speed [rpm]
AM80/90/RS, AM143/145/RS	575	820
AM100/112/RS, AM182/184/RS	3760	620
AM132/RS, AM213/215/RS	7525	530
AM160/180/RS, AM254/286/RS	12830	480
AM200/225/RS, AM324-365/RS	17260	450
AM250/280/RS	17260	450

4.8 AR adapter with torque limiting coupling

If torque limiting is desired for compound gear units (ex: R77R37..), the AR adapter containing a torque limiting coupling should preferably be placed between the two gear units (ex: R77AR95R37...) rather than placed at the motor. Please contact SEW-EURODRIVE if you intend to use a torque limiting coupling with a compound gear unit.

Selecting the gear unit

If torque limiting is required for a single gear unit (ex:R77), the AR adapter is placed between the gear unit and motor. The sizes of the AR adapters correspond to those of the AM adapters for IEC motors.

This means you can select the gear unit using the selection tables for IEC AM adapters. Then, substitute the unit designation "AM" with "AR" and determine the required slip torque.

The slip torque should be about 1.5 times the rated torque of the drive. When determining the slip torque, bear in mind the maximum permissible output torque of the gear unit as well as the variations in the slip torque of the coupling (+/-20%) which are a feature of the design.

When you order a gear unit with adapter and torque limiting coupling, please specify the required slip torque of the coupling. If you do not specify, it will be set according to the maximum permissible output torque of the gear unit.

Slip torque values

Type	$P_m^{1)}$ [HP]	$M_R^{2)}$ [lb-in]		
		Option 1	Option 2	Option 3
AR71	.50	9 - 53	54 - 142	-
AR80	1.0	9 - 53	54 - 142	-
AR90	2.0	9 - 53	54 - 142	150 - 285
AR100	4.0	44 - 115	124 - 708	-
AR112	5.4	44 - 115	124 - 708	-
AR132S/M	10	133 - 1150	-	-
AR132ML	12.5	133 - 1150	-	-
AR160	20	265 - 750	760 - 1770	-
AR180	30	265 - 750	760 - 2660	-

1) Maximum rated power of the mounted electric motor at 1750 rpm

2) Adjustable slip torque according to cup springs

4 Project Planning

AR adapter with torque limiting coupling

Speed monitor option /W



SEW-EURODRIVE recommends monitoring the speed of the coupling using a speed monitor to avoid uncontrolled slippage of the coupling and the associated wear on the friction ring pads.

The speed of the output end coupling half is detected in a proximity-type method using a trigger cam and an inductive encoder. The speed monitor compares the pulses with a defined reference speed. The output relay (NC or NO contact) trips when the speed drops below the specified speed (overload). The monitor is equipped with a start bypass to suppress error messages during the startup phase. The start bypass can be set within a time window of 0.5 to 15 seconds.

Reference speed, start bypass and switching hysteresis can be set on the speed monitor.

The following figure shows the adapter with torque limiting coupling and speed monitor,

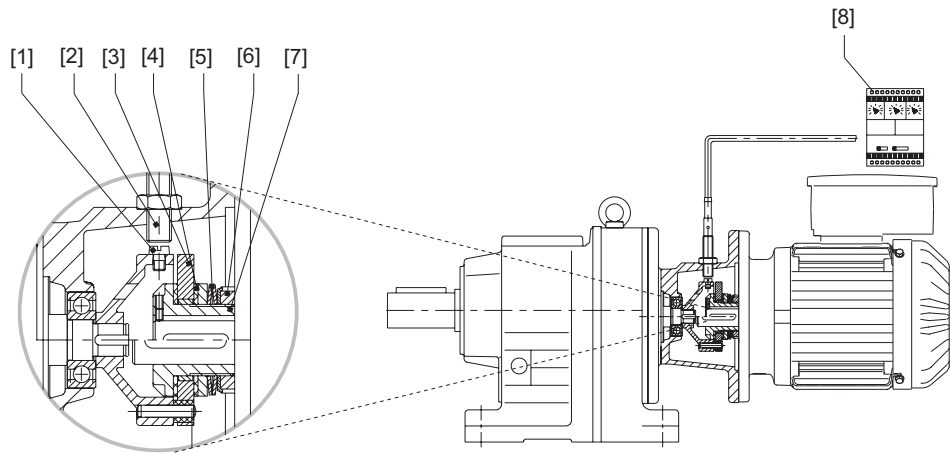

65931AXX

- | | |
|------------------------|-------------------|
| [1] Trigger cam | [5] Cup spring |
| [2] Encoder (adapter) | [6] Slotted nut |
| [3] Driving disk | [7] Friction hub |
| [4] Friction ring pads | [8] Speed monitor |

Connection

The encoder is connected to the slip monitor using a two or three-core cable (depending on the encoder type).

- Maximum cable length: 500 m with a line cross section of 1.5 mm²
- Standard supply cable: 3-core / 2 m
- Route the signal lines separately (not in multicore cables) and shield them, if necessary.
- Degree of protection: IP40 (terminals IP20)
- Operating voltage: AC 220 V or DC 24 V
- Maximum switching capability of the output relay: 6 A (AC 250 V)

Terminal assignment

The following figure shows the terminal assignment for /W:

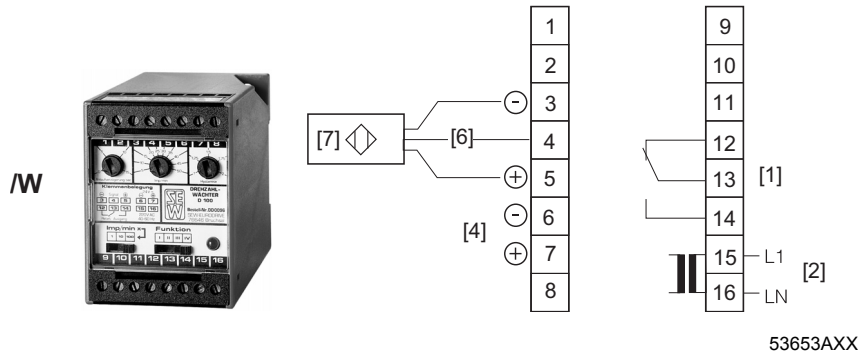

- | | | | |
|-----|---|-----|---------------|
| [1] | Relay output | [6] | Signal |
| [2] | Connection voltage AC 230 V (47 to 63 Hz) | [7] | Encoder |
| [3] | External slip reset | [W] | Speed monitor |
| [4] | DC 24 V supply voltage | | |
| [5] | Jumper for synchronous operation monitoring | | |

Dimensions

The following figure shows the dimensions for /W:

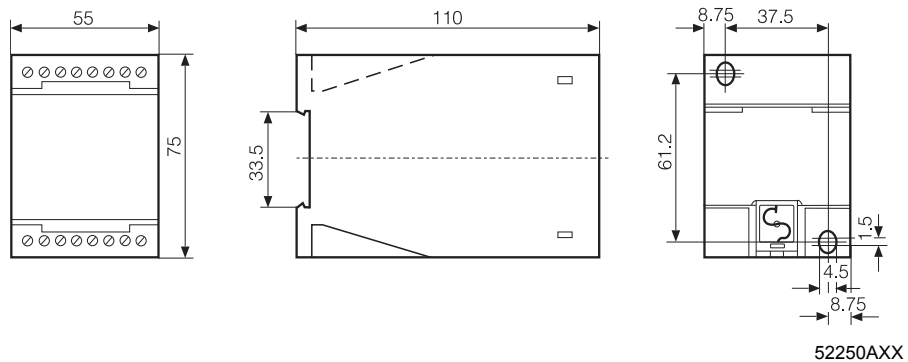

4.9 AD input shaft

Selecting the gear unit

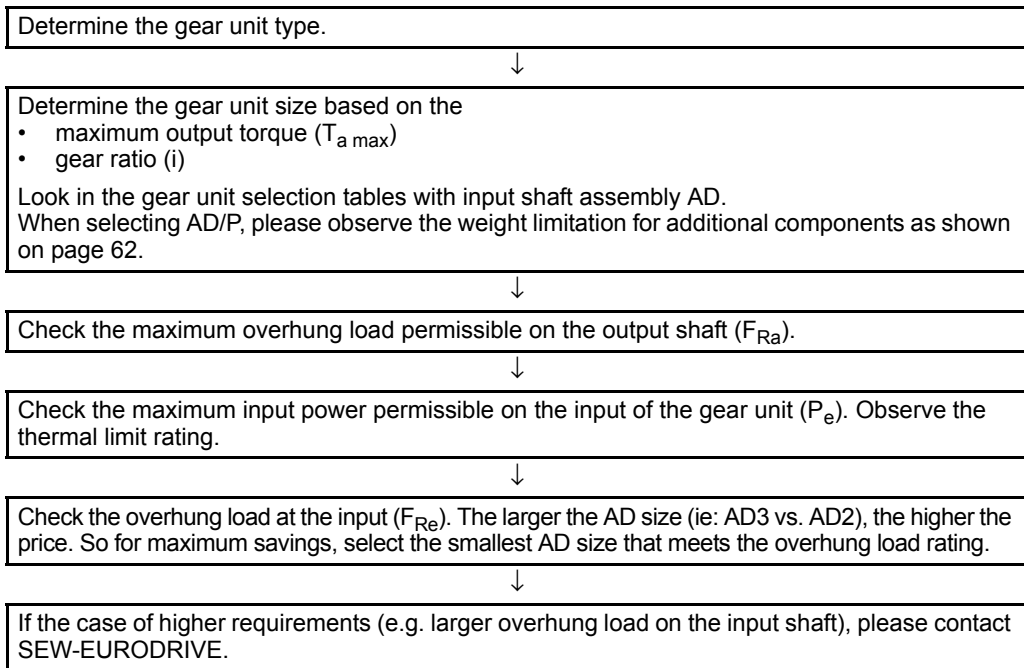

Centering shoulder AD../ZR

The input shaft assembly can be configured with a machined centering shoulder as an option. This allows the customer to locate the exact center of the input shaft for proper alignment.

Backstop AD../RS

The input shaft assembly can be supplied with a backstop if only one direction of rotation is permissible. Backstops with centrifugal lift-off sprags are used. The advantage of this design is that above a certain speed (lift-off speed), the sprags move around inside the backstop without making contact. Therefore, the backstop is suited for high speeds and operates maintenance free, wear-free, and without losses.

Dimensions:

The backstop is completely integrated inside the cover. Therefore, there is no difference in dimensions between an input shaft assembly with or without a backstop (see dimension sheets in the "Input shaft assembly AD" chapter).

Locking torques:

Type	Maximum backstop locking torque [lb-in]	Minimum lift-off speed [rpm]
AD2/RS	575	820
AD3/RS	3760	620
AD4/RS	7525	530
AD5/RS	12830	480
AD6/RS	17260	450
AD7/RS	17260	450
AD8/RS	17260	450

Motor mounting platform AD.. /P

Available combinations

The following table shows the motors that are available for each mounting platform. The highlighted cells show the additional weight (lbs) that is permissible for installed components (pulley, sprockets, belts, etc).

DRS Motor	Motor mounting platform					
	AD2/P	AD3/P	AD4/P	AD5/P	AD6/P	AD7/P
DRS71S	12					
DRS71M	12					
DRS80S	12					
DRS80M	12	25				
DRS90M	12	25				
DRS90L		25				
DRS100M		25				
DRS100L		25				
DRS100LC		25				
DRS112M		25				
DRS132S			50			
DRS132M			50			
DRS132MC			50			
DRS160S			50	90		
DRS160M				90		
DRS160MC				90		
DRS180S				90		
DRS180M				90		
DRS180L				90		
DRS180LC				90		
DRS200L					135	
DRS225S					135	
DRS225M					135	
DRS225MC					135	
DV250						225
DV280						225

 Combination is available / additional weight for installed components (lb)

Permissible Weights

Permissible weights for installed components (pulley, sprockets, belts, etc).



DRE Motor	Motor mounting platform					
	AD2/P	AD3/P	AD4/P	AD5/P	AD6/P	AD7/P
DRE80S	12					
DRE80M	12					
DRE90M	12	25				
DRE90L	12	25				
DRE100M		25				
DRE100L		25				
DRE100LC		25				
DRE112M		25				
DRE132S		25				
DRE132M			50			
DRE132MC			50			
DRE160S			50	90		
DRE160M				90		
DRE160MC				90		
DRE180S				90		
DRE180M				90		
DRE180L				90		
DRE180LC				90		
DRE200L					135	
DRE225S					135	
DRE225M					135	
DVE250						225
DVE280						225

DRP Motor	Motor mounting platform					
	AD2/P	AD3/P	AD4/P	AD5/P	AD6/P	AD7/P
DRP80M	12					
DRP90M	12	25				
DRP90L	12	25				
DRP100M		25				
DRP100L		25				
DRP100LC		25				
DRP112M		25				
DRP132M			50			
DRP132MC			50			
DRP160S			50	90		
DRP160M			50	90		
DRP160MC				90		
DRP180S				90		
DRP180M				90		
DRP180L				90		
DRP180LC				90		
DRP200L					135	
DRP225S					135	
DRP225M					135	
DRP225MC					135	

Combination is available / additional weight for installed components (lb)

Thermal limitations with AD input

The power values given in the selection tables for gear units with AD input shaft assembly are based upon mechanical limitations. However, depending on the mounting position, gear units may become thermally overloaded before they reach the mechanical limit. The column in the selection tables (as circled below) lists mounting positions that may reduce the input power rating for each ratio.

R107 AD... , $n_e = 1700$ rpm										38060 lb-in
i [ratio]	n_a [rpm]	T_{amax} [lb-in]	P_e [HP]	F_{Ra} [lb]	F_{Re} [lb]	Stages Lg Sm	φ (R) [°]			

50494AUS

Please contact SEW-EURODRIVE if the mounting position you require is shown in this column. By considering the actual operating conditions, SEW-EURODRIVE can calculate the thermal limit rating based upon the specific application. Often, alternate measures are available (ex: using FKM seals and a synthetic lubricant with higher thermal stability) to increase the thermal rating of the gear unit.

The following data is required for recalculation:

Gear unit type	... R, S, K, F, or W
Gear unit size	... 37, 47, etc.
Input speed rpm
Gear ratio, i	
Cyclic duration factor, CDF %
Ambient temperature °C
Load power HP
Environment / convection	... in small, enclosed rooms ... in large rooms, halls ... outdoors
Installation / conduction	... base made of steel or concrete

INFORMATION	
	You may also visit our online selection program at www.ptpilot.com . PT Pilot automatically calculates your oil sump temperature based upon your mounting position and ambient temperature. When applicable, PT Pilot® adds synthetic oil and FKM seals for proper protection against heat.

4.10 RM - extended bearing housing

Project Planning You must take account of the higher overhung and axial loads when planning projects with RM helical gear units with extended bearing hub. Observe the following project planning procedure. Note that all values are **metric**.

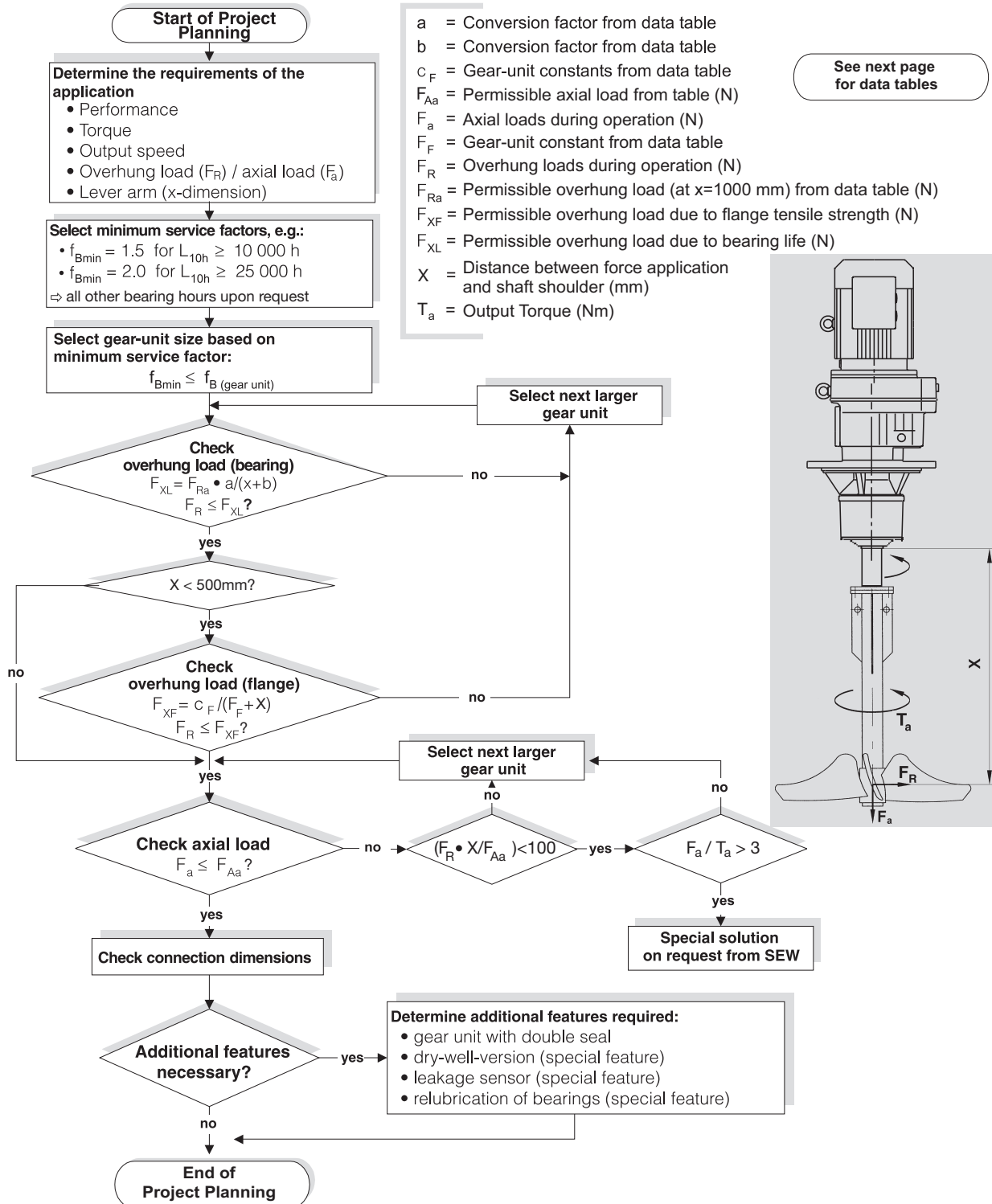

02457BUS

**Permissible
overhung loads
and axial forces**

The permissible overhung loads F_{Ra} and axial forces F_{Aa} are listed below for various service factors f_B and nominal bearing service life L_{10h} .

$f_{Bmin} = 1.5; L_{10h} = 10,000 h$

		Output speed n_a [rpm]							
		< 16	16-25	26-40	41-60	61-100	101-160	161-250	251-400
RM57	F_{Ra} [N]	400	400	400	400	400	405	410	415
	F_{Aa} [N]	18800	15000	11500	9700	7100	5650	4450	3800
RM67	F_{Ra} [N]	575	575	575	580	575	585	590	600
	F_{Aa} [N]	19000	18900	15300	11900	9210	7470	5870	5050
RM77	F_{Ra} [N]	1200	1200	1200	1200	1200	1210	1210	1220
	F_{Aa} [N]	22000	22000	19400	15100	11400	9220	7200	6710
RM87	F_{Ra} [N]	1970	1970	1970	1970	1980	1990	2000	2010
	F_{Aa} [N]	30000	30000	23600	18000	14300	11000	8940	8030
RM97	F_{Ra} [N]	2980	2980	2980	2990	3010	3050	3060	3080
	F_{Aa} [N]	40000	36100	27300	20300	15900	12600	9640	7810
RM107	F_{Ra} [N]	4230	4230	4230	4230	4230	4230	3580	3830
	F_{Aa} [N]	48000	41000	30300	23000	18000	13100	9550	9030
RM137	F_{Ra} [N]	8710	8710	8710	8710	7220	5060	3980	6750
	F_{Aa} [N]	70000	70000	70000	57600	46900	44000	35600	32400
RM147	F_{Ra} [N]	11100	11100	11100	11100	11100	10600	8640	10800
	F_{Aa} [N]	70000	70000	69700	58400	45600	38000	32800	30800
RM167	F_{Ra} [N]	14600	14600	14600	14600	14600	14700	-	-
	F_{Aa} [N]	70000	70000	70000	60300	45300	36900	-	-

$f_{Bmin} = 2.0; L_{10h} = 25,000 h$

		Output speed n_a [rpm]							
		< 16	16-25	26-40	41-60	61-100	101-160	161-250	251-400
RM57	F_{Ra} [N]	410	410	410	410	410	415	415	420
	F_{Aa} [N]	12100	9600	7350	6050	4300	3350	2600	2200
RM67	F_{Ra} [N]	590	590	590	595	590	595	600	605
	F_{Aa} [N]	15800	12000	9580	7330	5580	4460	3460	2930
RM77	F_{Ra} [N]	1210	1210	1210	1210	1210	1220	1220	1220
	F_{Aa} [N]	20000	15400	11900	9070	6670	5280	4010	3700
RM87	F_{Ra} [N]	2000	2000	2000	2000	2000	1720	1690	1710
	F_{Aa} [N]	24600	19200	14300	10600	8190	6100	5490	4860
RM97	F_{Ra} [N]	3040	3040	3040	3050	3070	3080	2540	2430
	F_{Aa} [N]	28400	22000	16200	11600	8850	6840	5830	4760
RM107	F_{Ra} [N]	4330	4330	4330	4330	4330	3350	2810	2990
	F_{Aa} [N]	32300	24800	17800	13000	9780	8170	5950	5620
RM137	F_{Ra} [N]	8850	8850	8850	8830	5660	4020	3200	5240
	F_{Aa} [N]	70000	59900	48000	37900	33800	31700	25600	23300
RM147	F_{Ra} [N]	11400	11400	11400	11400	11400	8320	6850	8440
	F_{Aa} [N]	70000	60600	45900	39900	33500	27900	24100	22600
RM167	F_{Ra} [N]	15100	15100	15100	15100	15100	13100	-	-
	F_{Aa} [N]	70000	63500	51600	37800	26800	23600	-	-

Conversion factors and gear unit constants

The following conversion factors and gear unit constants apply to calculating the permissible overhung load F_{xL} at point $x \neq 1000$ mm for RM gearmotors:

Gear unit type	a	b	$c_F (f_B = 1.5)$	$c_F (f_B = 2.0)$	F_F
RM57	1047	47	1220600	1260400	277
RM67	1047	47	2047600	2100000	297.5
RM77	1050	50	2512800	2574700	340.5
RM87	1056.5	56.5	4917800	5029000	414
RM97	1061	61	10911600	11124100	481
RM107	1069	69	15367000	15652000	554.5
RM137	1088	88	25291700	25993600	650
RM147	1091	91	30038700	31173900	756
RM167	1089.5	89.5	42096100	43654300	869

Additional weight of RM gear units

Type	Additional weight of RM compared to RF (compared to the smallest RF flange) Δ weight [lbs]
RM57	+26
RM67	+35
RM77	+55
RM87	+66
RM97	+113
RM107	+194
RM137	+245
RM147	+369
RM167	+431

4.11 DUO - Oil aging monitor



DUO10A diagnostic unit

DUO10A	Technical data
Preset oil grades	OIL1 CLP mineral oil. $T_{max} = 100\text{ °C}$ Bio oil $T_{max} = 100\text{ °C}$
	OIL2 CLP HC synthetic oil: $T_{max} = 130\text{ °C}$ CLP PAO oil $T_{max} = 130\text{ °C}$
	OIL3 CLP PG polyglycol $T_{max} = 130\text{ °C}$
	OIL4 Food grade oil $T_{max} = 100\text{ °C}$
Switch outputs	
Permitted oil temperature	-40 °C to +130 °C
Permitted temperature sensor	PT1000
EMC	IEC1000-4-2/3/4/6
Ambient temperature	-25 °C to +70 °C
Operating voltage	DC 18-28 V
Current consumption for DC 24 V	< 90 mA
Protection class	III
Degree of protection	IP67 (optionally IP69K)
Housing materials	Evaluation unit: V2A, EPDM/X, PBT, FPM Temperature sensor: V4A
Electrical connection	Evaluation unit: M12 plug connector PT1000 temperature sensor: M12 plug connector

Designations and part numbers

Designation	Description	Part number
DUO10A	Evaluation unit (basic unit)	1 343 875 1
DUO10A-PUR-M12-5m	5 m PUR cable with 1 connector	1 343 877 8
DUO10A-PVC-M12-5m	5 m PVC cable with 1 connector	1 343 878 6
DUO10A	Angle bracket	1 343 880 8
DUO10A D = 34	Mounting clamp	1 343 879 4



Designation	Description	Part number
W4843 PT1000 	PT1000 temperature sensor	1 343 881 6
W4843_4x0.34-2m-PUR	2 m PUR cable for PT1000 ¹⁾	1 343 882 4
W4843_4x0.34-2m-PVC	2 m PVC cable for PT1000 ²⁾	1 343 883 2
DUO10A 	Protection cap (for aseptic design, IP69K)	1 343 902 2

- 1) PUR cables are particularly suited for use in oil-contaminated environments.
 2) PVC cables are particularly suited for use in wet environments.

Mounting on standard gear units (R, F, K, S)

Adapter for mounting the PT1000 temperature sensor in screw plug holes:

Complete adapter for PT1000 sensor	Part number
M10 × 1	1 343 903 0
M12 × 1.5	1 343 904 9
M22 × 1.5	1 343 905 7
M33 × 2	1 343 906 5
M42 × 2	1 343 907 3

Mounting base for installing the diagnostic unit at the gear unit with an angle bracket:

Mounting base with sealing ring	Part number
M10 × 1	1 343 441 1
M12 × 1.5	1 343 827 1
M22 × 1.5	1 343 829 8
M33 × 2	1 343 830 1
M42 × 2	1 343 832 8

5 Mounting Positions

5.1 General information

The following figure shows the position of the gear unit in mounting positions M1 to M6:

65873axx

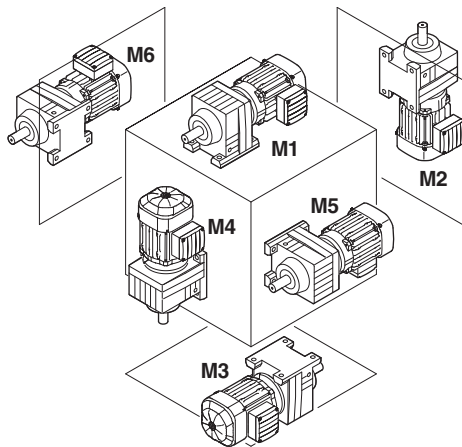

R..

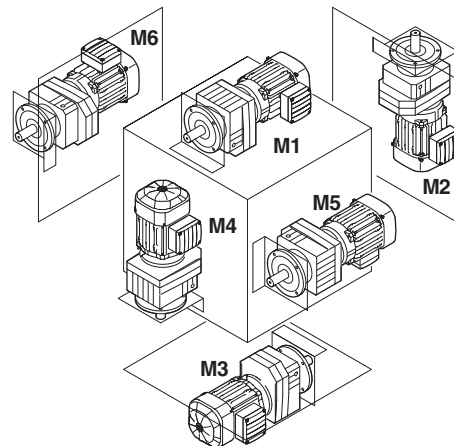

F..

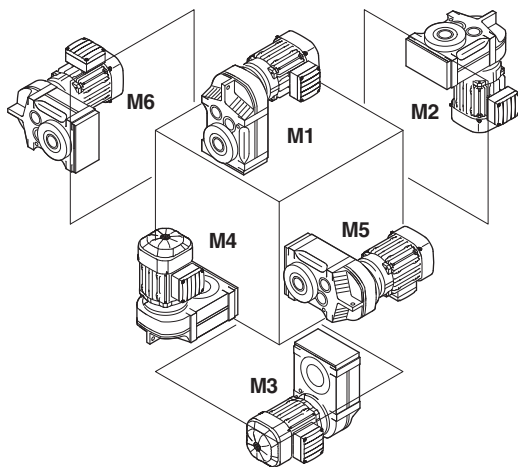

K..
S..
W..

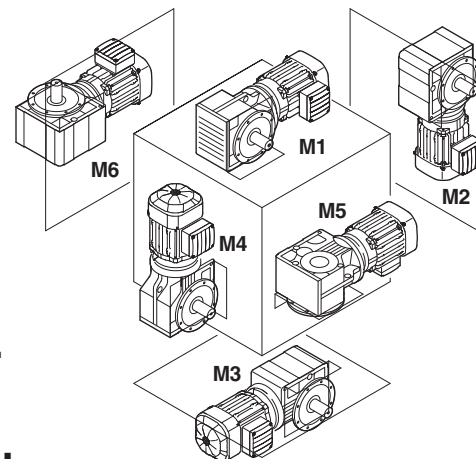





5 Mounting Positions

General information

Symbols

The following table shows the symbols used in the mounting position sheets and their meaning:

Symbol	Meaning
	Breather valve
	Oil level plug ¹⁾
	Oil drain plug
	Cable entry position "3"

1) Does not apply to the first gear unit (larger gear unit) of multi-stage gear units

Thermal losses

Excessive thermal losses may occur in some mounting positions due to large amount of oil churning, as noted below. The resultant heat may limit the input HP capacity or require additional protection against heat damage. See page 45 for explanation of thermal losses.

Mounting position	Gear unit type	Gear unit size	Input speed [rpm]
M2, M4	R	97 ... 107	> 3600
		> 107	> 1800
M2, M3, M4, M5, M6	F	97 ... 107	> 3600
		> 107	> 1800
	K	77 ... 107	> 3600
		> 107	> 1800
	S	77 ... 97	> 3600

You may either contact SEW-EURODRIVE in the above cases, or you may visit PT Pilot[®] at www.ptpilot.com for online assistance. PT Pilot[®] considers oil churning losses and automatically calculating your permissible input HP based upon your mounting position and ambient temperature for any ratio and gear unit size. If necessary, it will add FKM seals and synthetic oil.

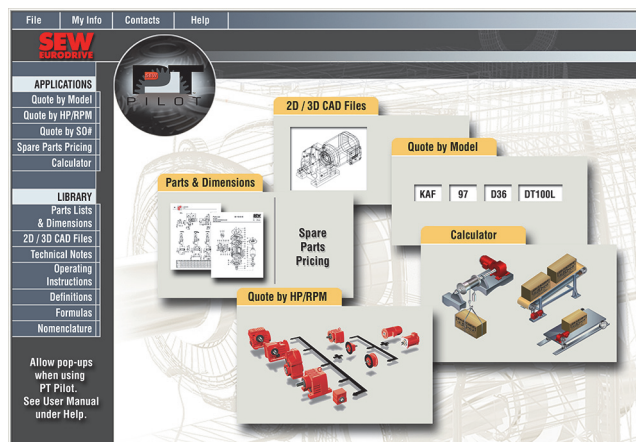

**Miscellaneous
Notes**

	INFORMATION
	<p>SPIROPLAN® gear units are not dependant on the mounting position, except for W..37 and W..47 in mounting position M4. However, mounting positions M1 to M6 are also shown for SPIROPLAN® gear units to assist you in working with this documentation.</p> <p>Important! Please note: SPIROPLAN® gear units W..10 to W..30 cannot be equipped with breather valves, oil level plugs, or drain plugs. SPIROPLAN® gear units W..37 and W..47 can be equipped with breather valves in mounting position M4 and with oil drain plugs in mounting position M2.</p>

	INFORMATION
	<p>Shafts:</p> <ul style="list-style-type: none"> • For gear units with solid shaft: The displayed shaft is always on the A end. • For shaft-mounted gear units: The shaft with dashed lines represents the customer's shaft. The shaft entry is always shown on the A side.

	INFORMATION
	<p>The permissible mounting surfaces are shown as hatched areas on the mounting position pages.</p>

5 Mounting Positions

R-series helical

5.2 R-series helical

RX57-RX107

01 001 00 10

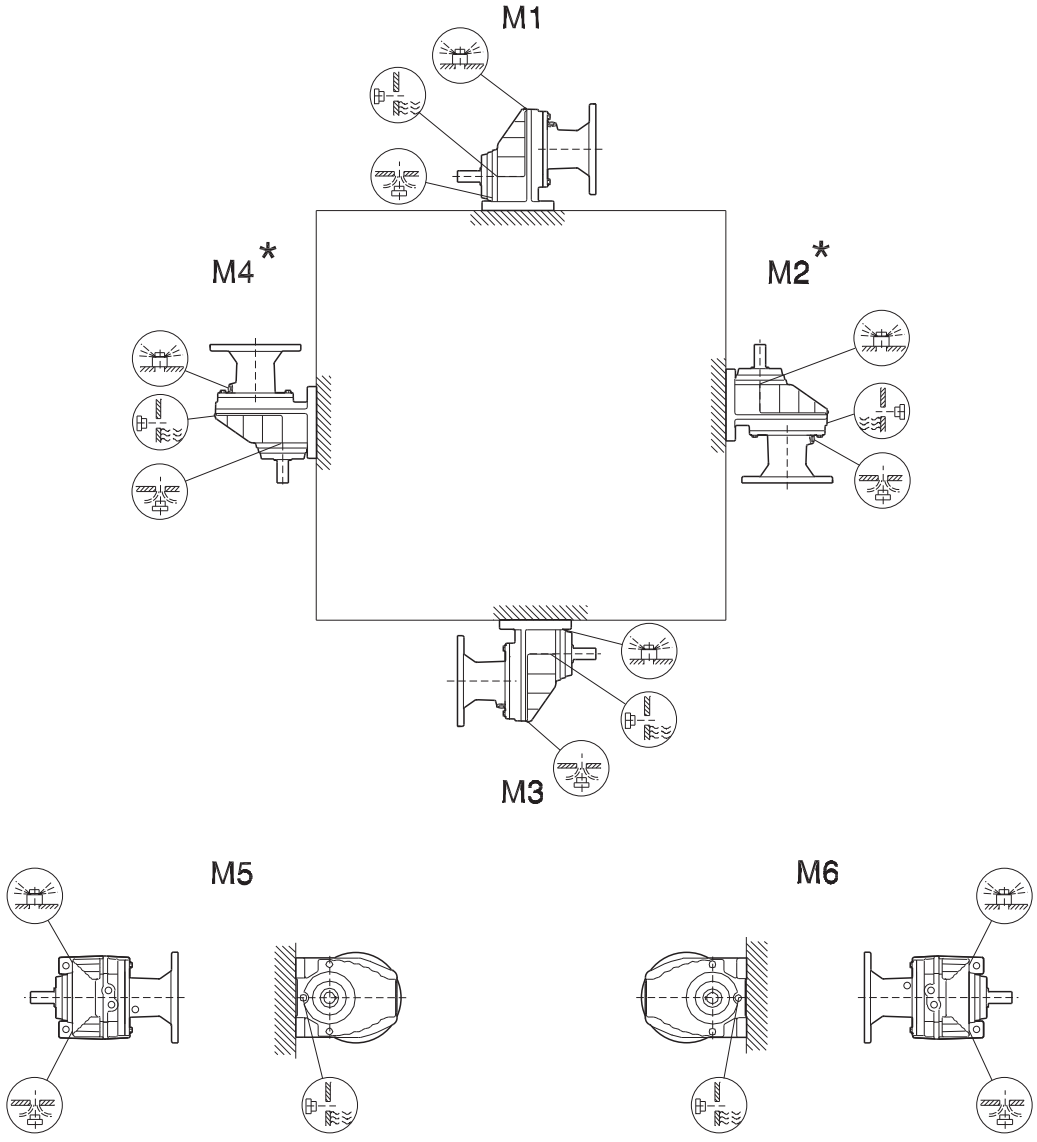

* → page 45 on thermal losses

RXF57-RXF107

01 002 00 10

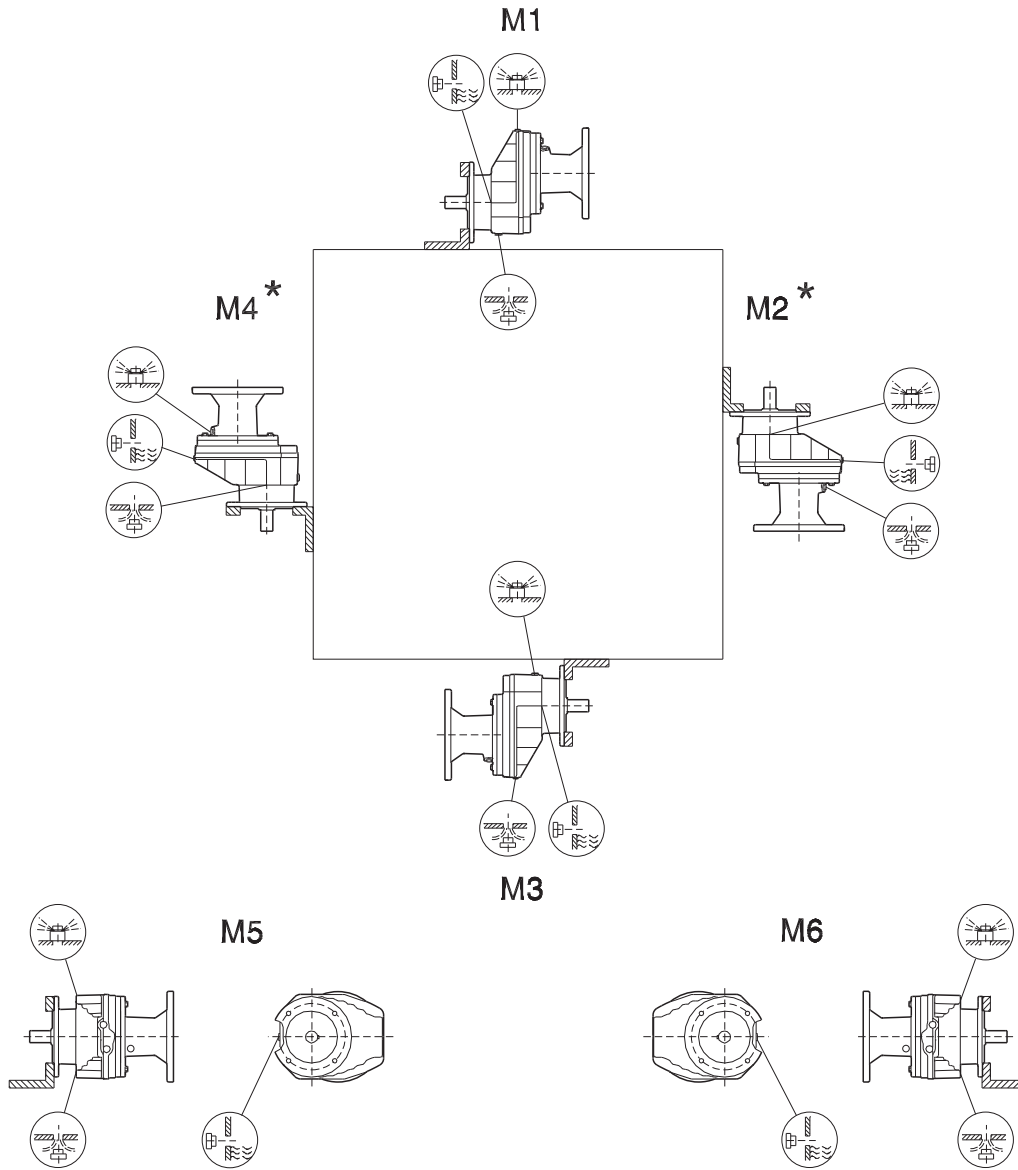

* → page 45 on thermal losses

5

5 Mounting Positions

R-series helical

R27-R167

01 003 00 10

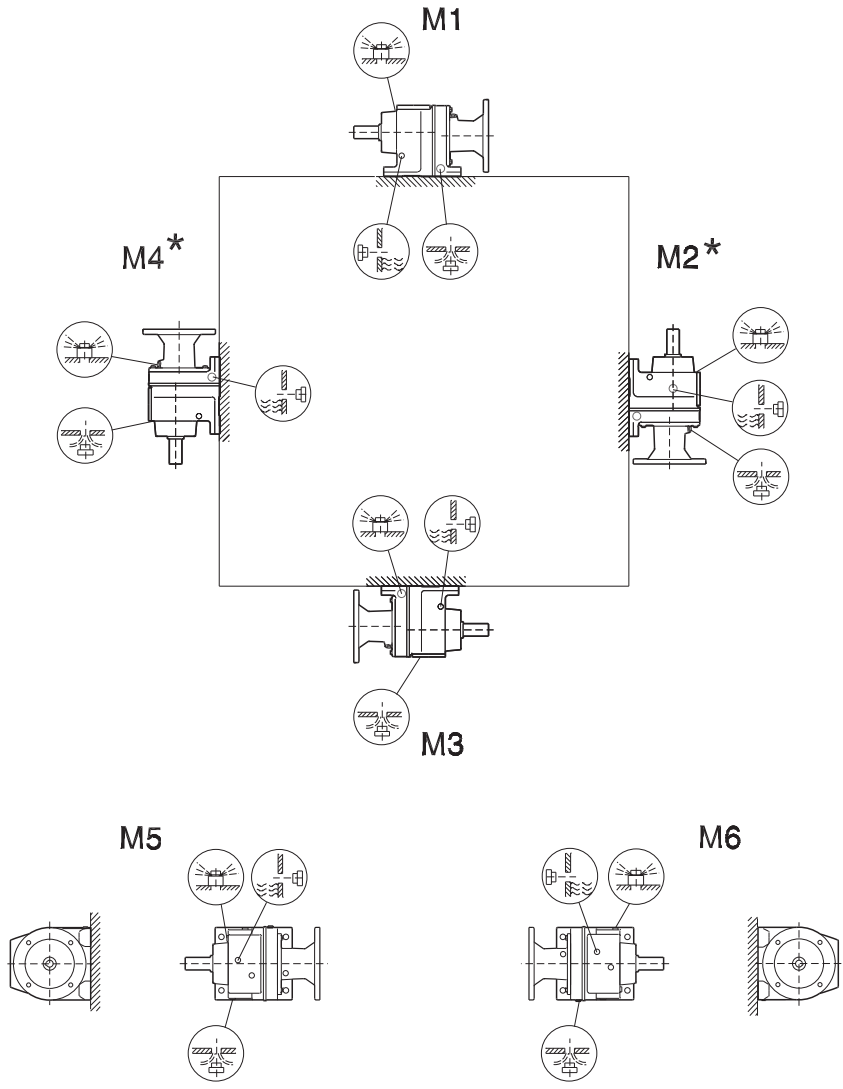

- R27 M1, M3, M5, M6
- R27
- R47, R57 M5

* → page 45 on thermal losses

RF27-RF167, RZ27-87

01 004 00 10

5

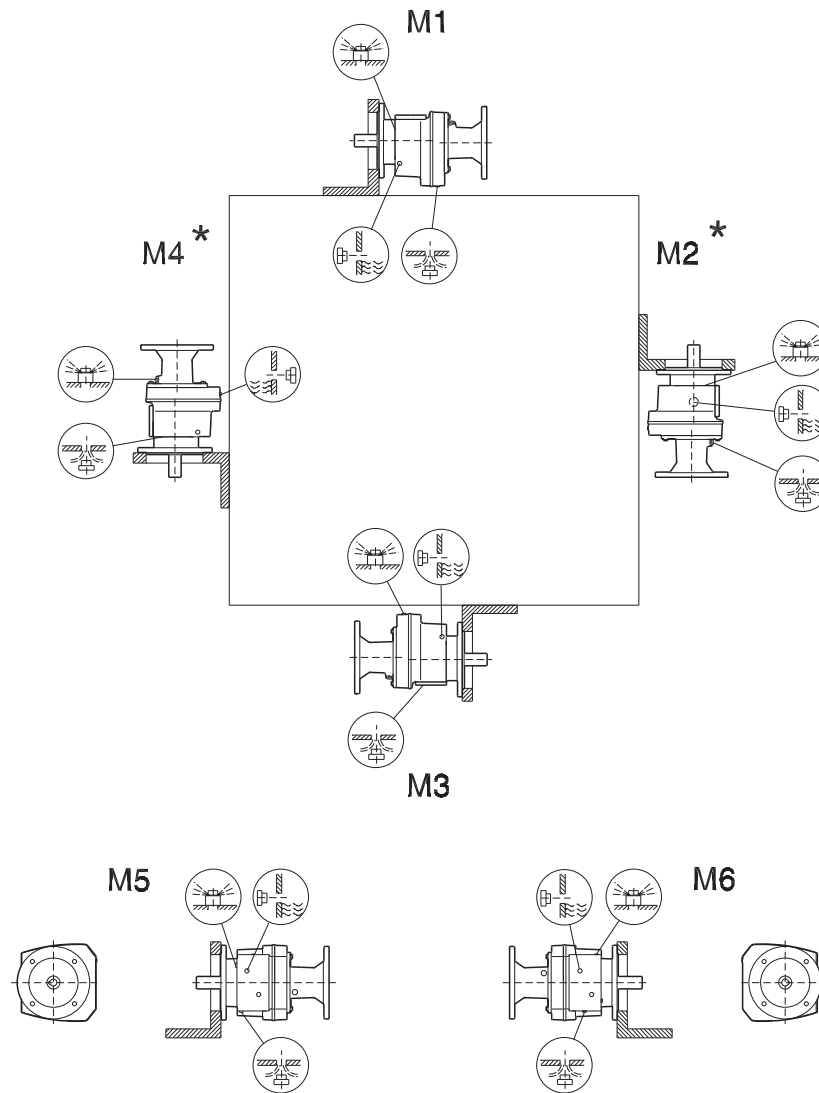

- RF/RZ27 ~~⊗~~ M1, M3, M5, M6
- RF/RZ27 ~~⊗~~ ~~⊗~~
- RF/RZ47, 57 ~~⊗~~ M5

* → page 45 on thermal losses

5 Mounting Positions

R-series helical

R27F-R87F

01 005 00 10

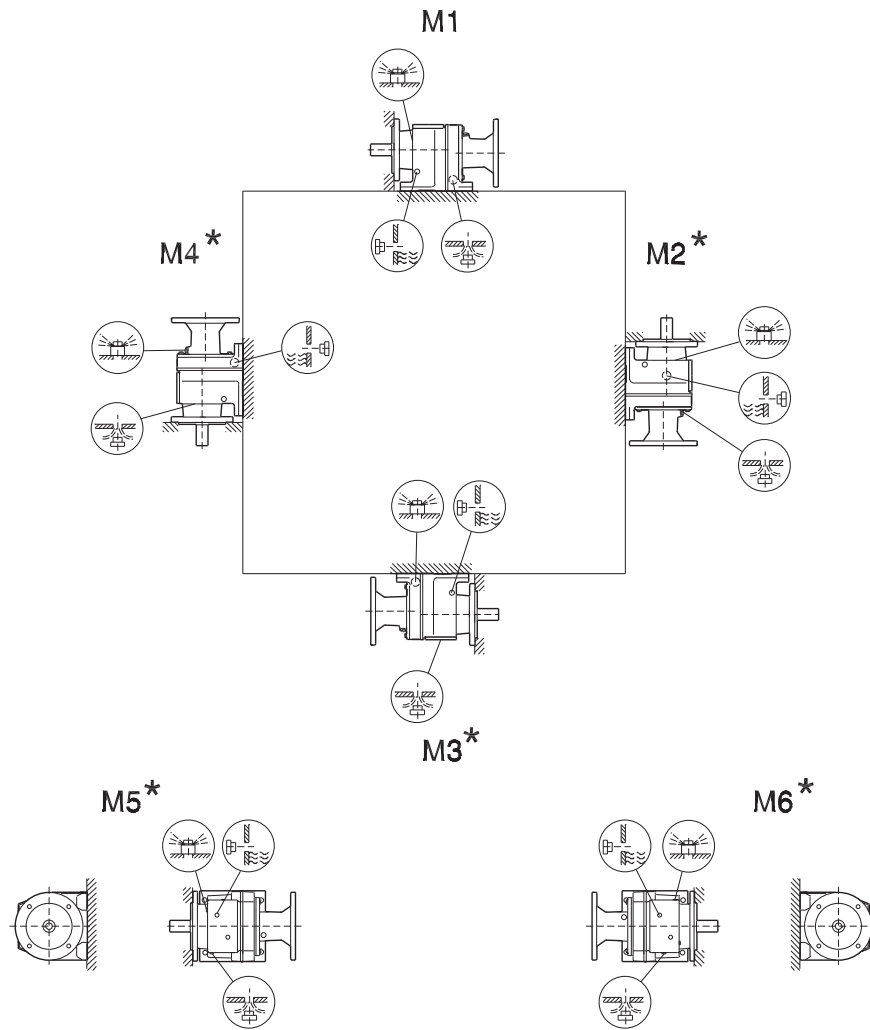

- | | | |
|------------|--|----------------|
| R27F | | M1, M3, M5, M6 |
| R27F | | |
| R47F, R57F | | M5 |

* → page 45 on thermal losses

Important:

Proper alignment must be ensured when two mounting surfaces are used!

The OHL, FRa, shown in the selection tables is reduced 50% if torque transmission occurs via the mounting flange.

5.3 F-series helical-parallel

F/FA..B/FH27B-157B, FV27B-107B

42 002 00 10

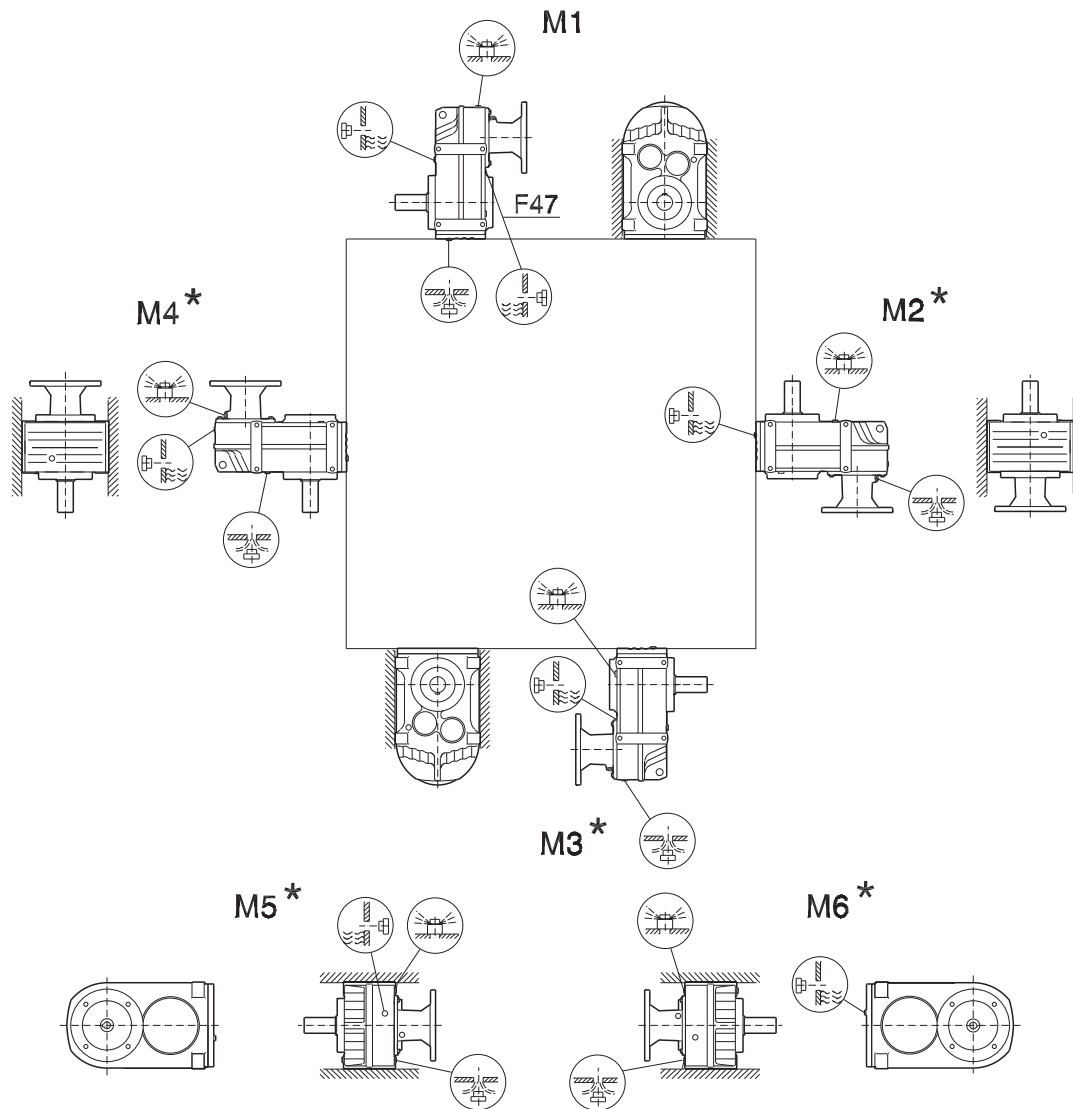

F..27  M1, M3, M5, M6

F..27  M1 - M6

F..27  M1, M3, M5, M6

* → page 45 on thermal losses

5 Mounting Positions

F-series helical-parallel

FF/FAF/FHF/FAZ/FHZ27-157, FVF/FVZ27-107

42 003 00 10

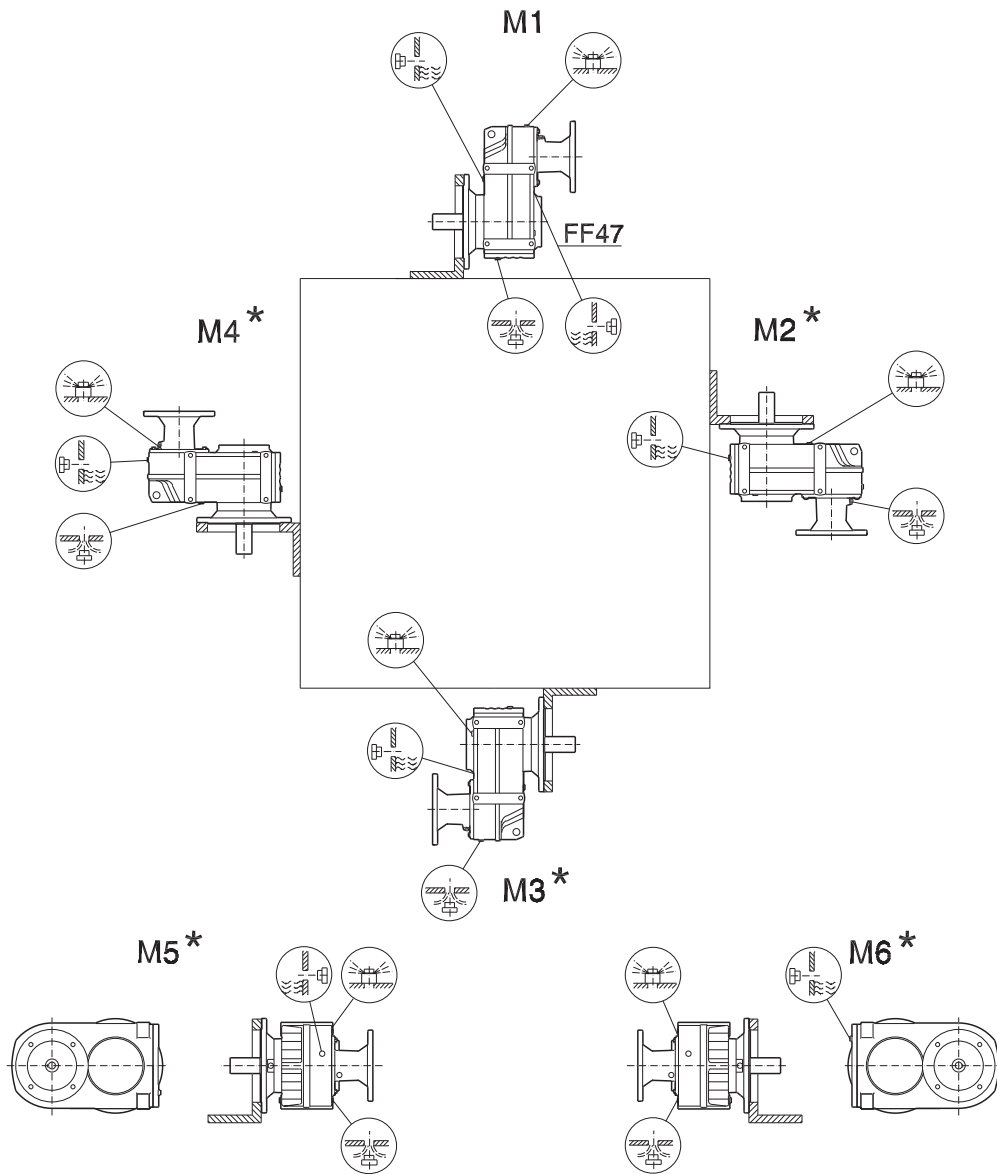

F..27  M1, M3, M5, M6

F..27  M1 - M6

F..27  M1, M3, M5, M6

* → page 45 on thermal losses

FA/FH27-157, FV27-107, FT37-97

42 004 00 10

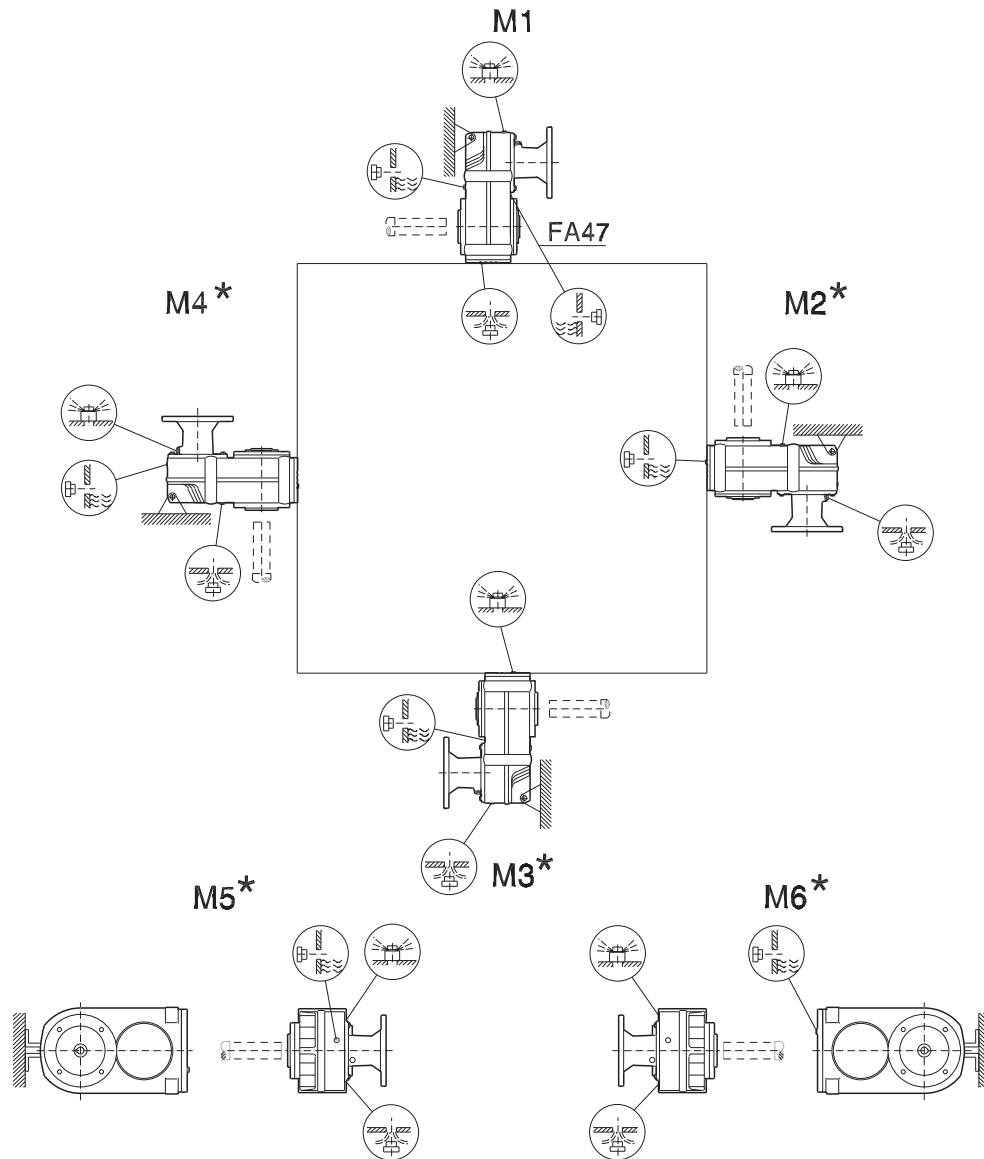

F..27  M1, M3, M5, M6

F..27  M1 - M6

F..27  M1, M3, M5, M6

* → page 45 on
thermal losses

5 Mounting Positions

K-series helical-bevel

5.4 K-series helical-bevel

K/KA..B/KH19B-29B (foot-mounted)

33 023 00 10

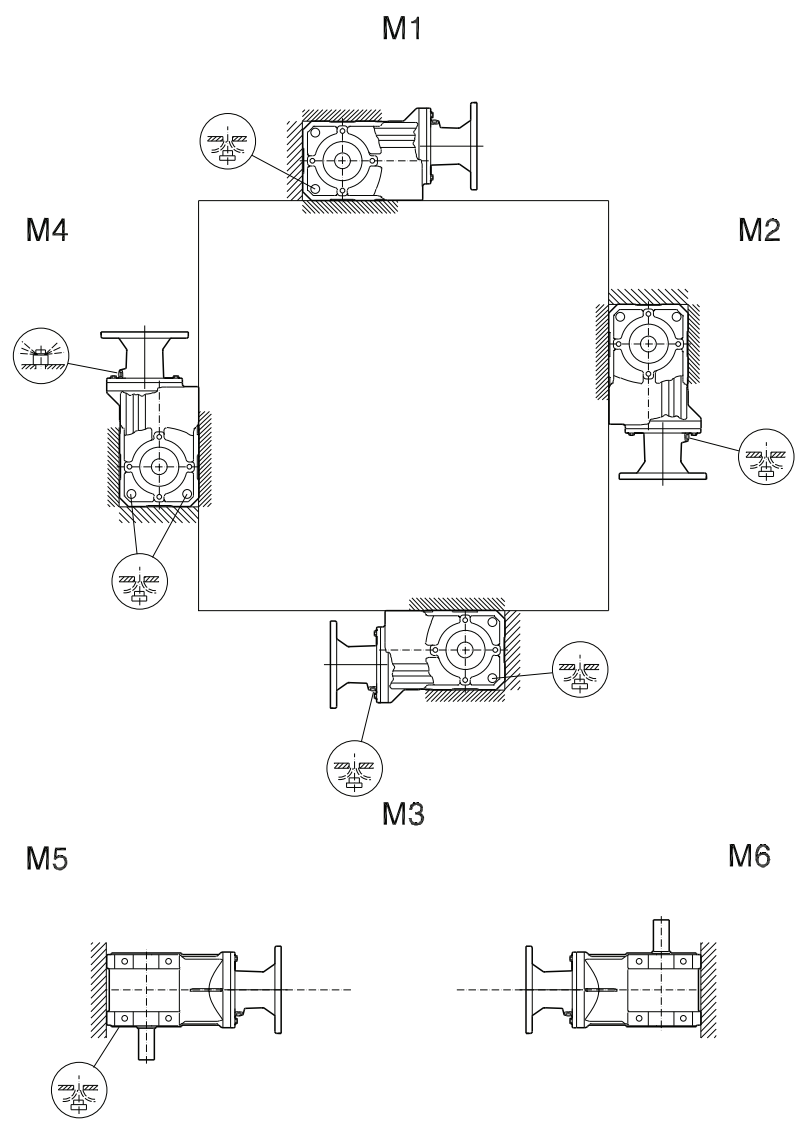
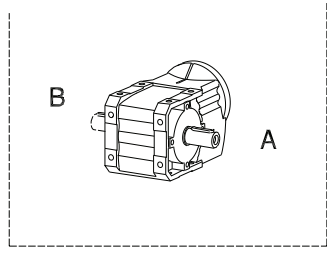

KF..B/KAF..B/KHF19B-29B (flange-mounted with footed gear unit)

33 024 00 10

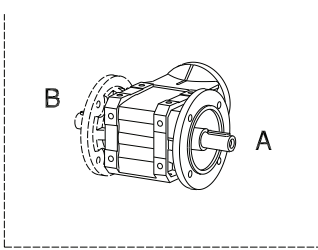

M1

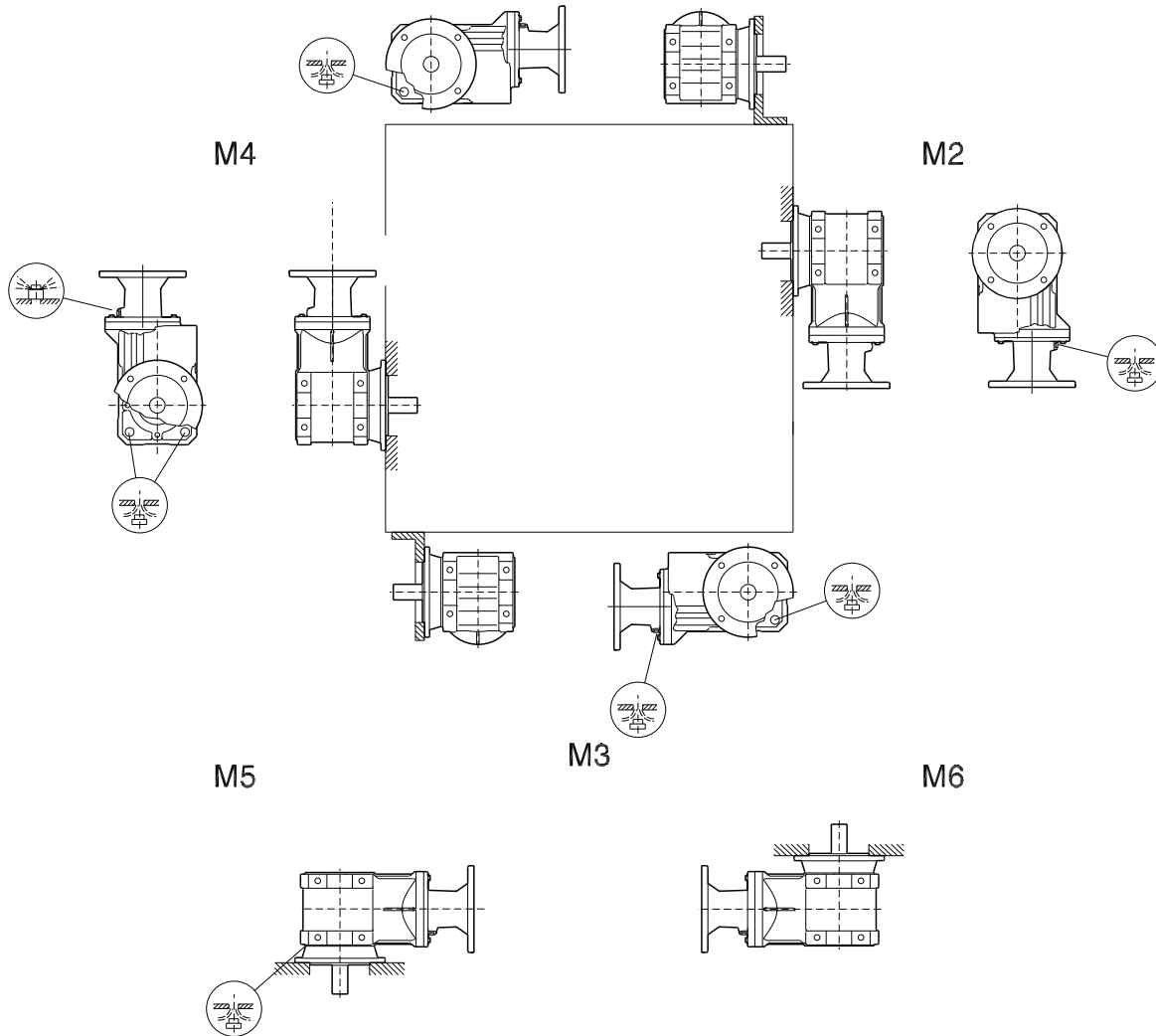

5

5 Mounting Positions

K-series helical-bevel

KA..B/KH19B-29B (shaft-mounted with footed gear unit)

33 025 00 10

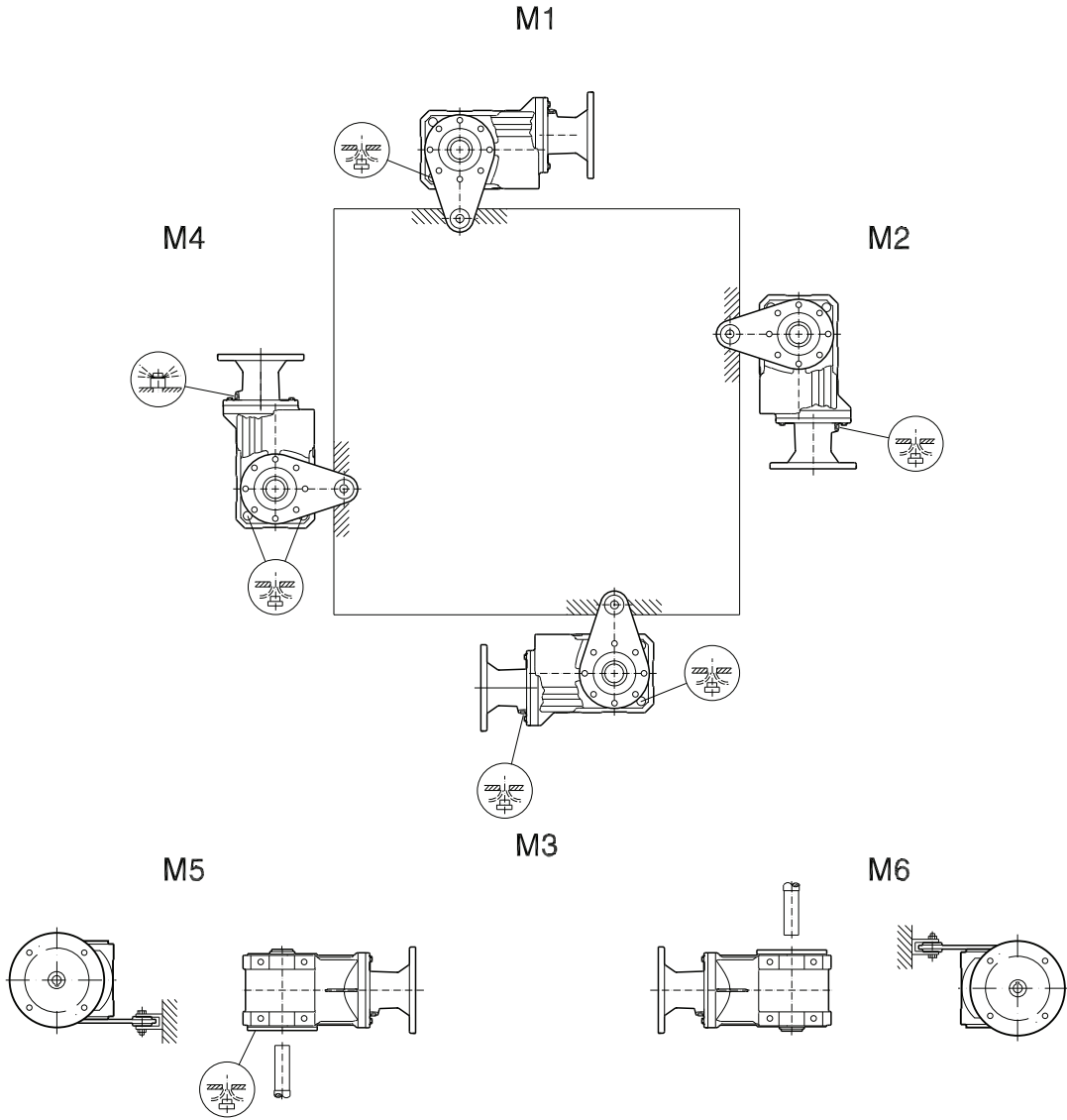
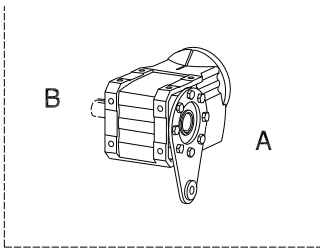

KF/KAF/KHF19-29 (flange-mounted without feet)

33 026 00 10

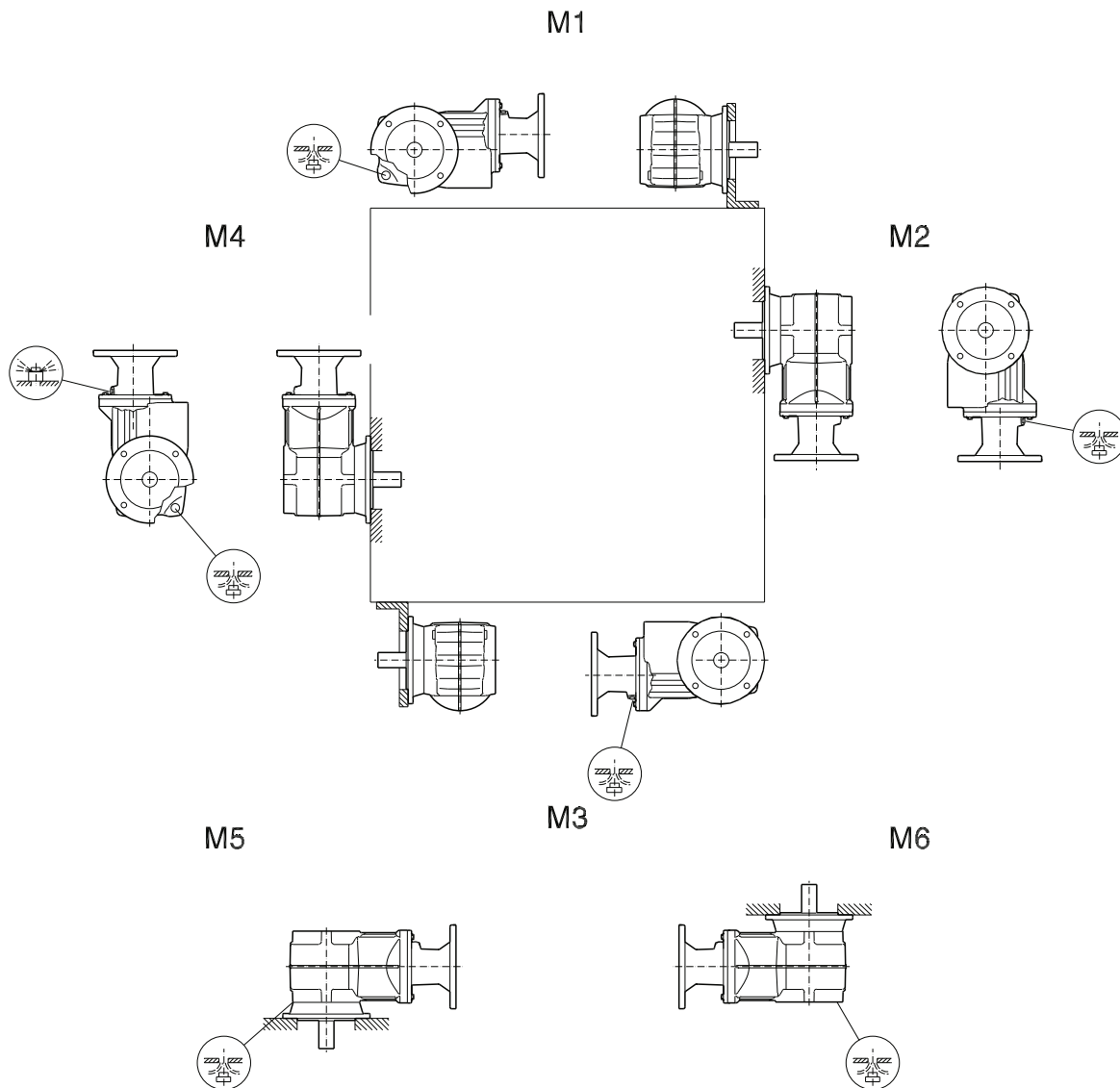
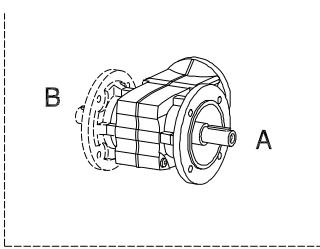

5 Mounting Positions

K-series helical-bevel

KA/KH19-29 (shaft-mounted without feet)

33 027 00 10

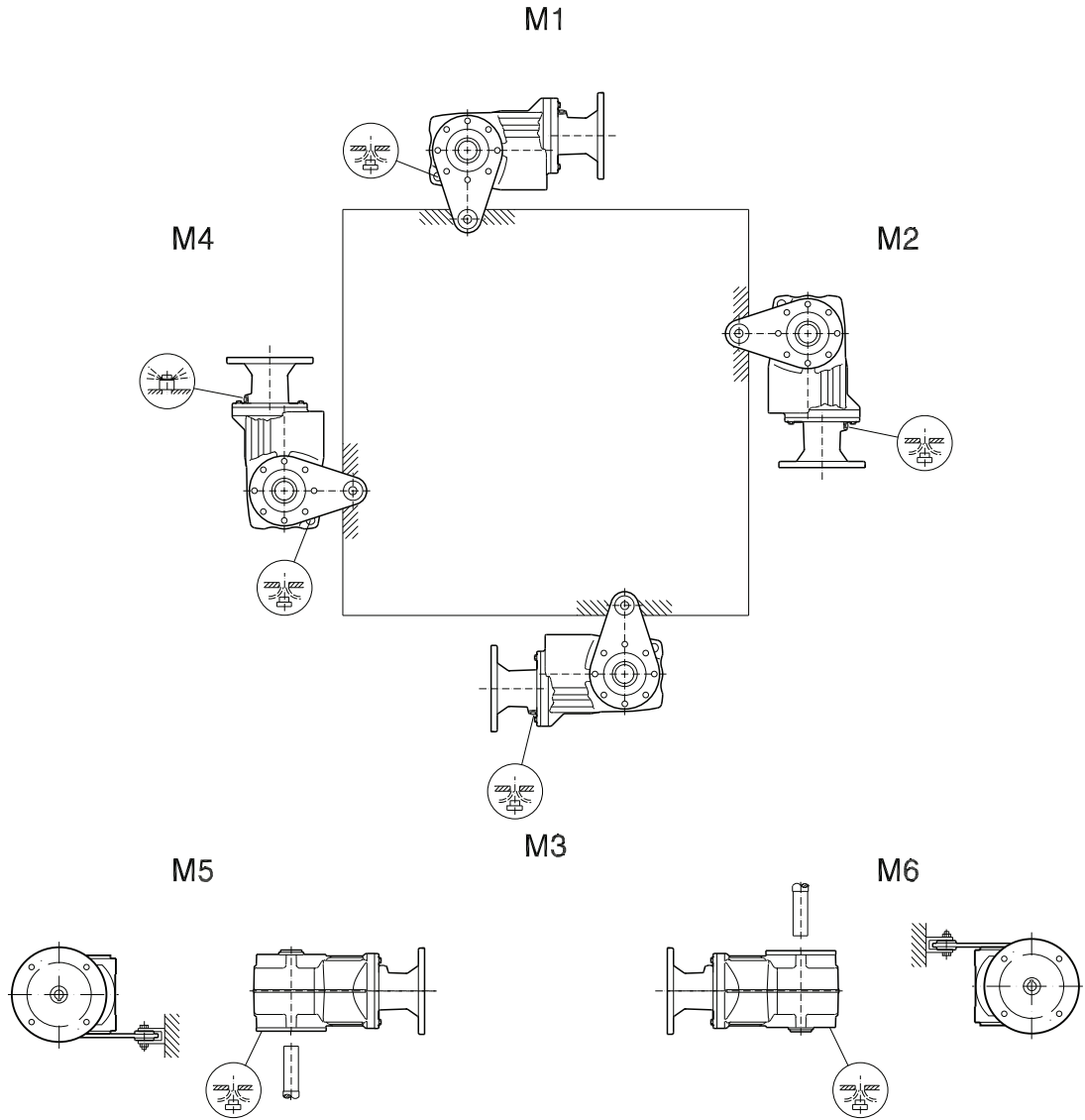
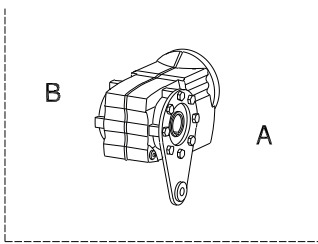

K39-49

33 092 00 10

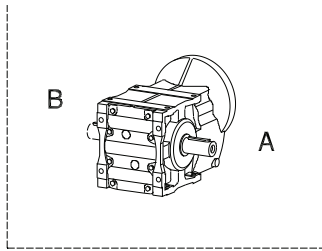

5

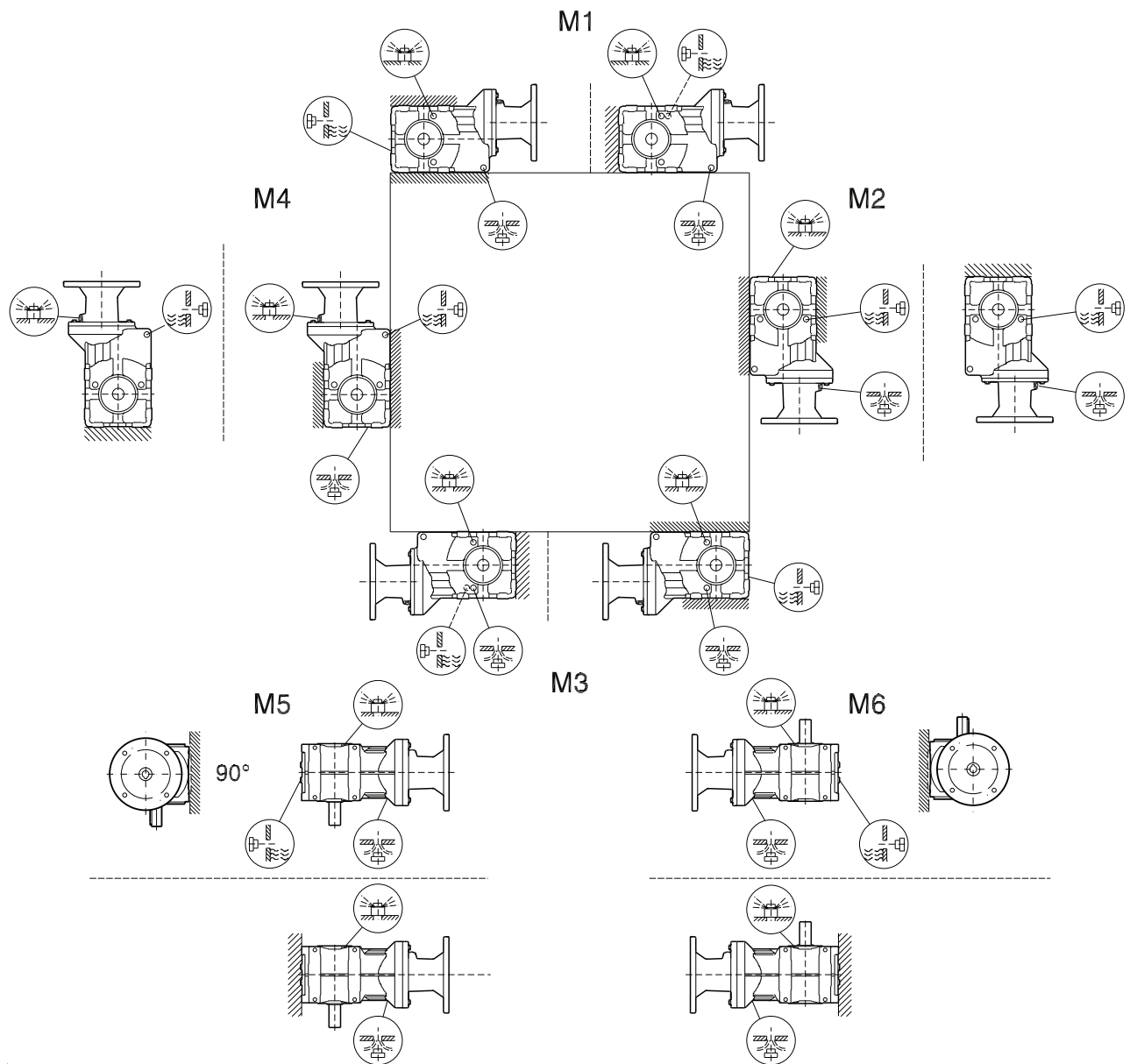

5 Mounting Positions

K-series helical-bevel

KF/KAF39-49

33 093 00 10

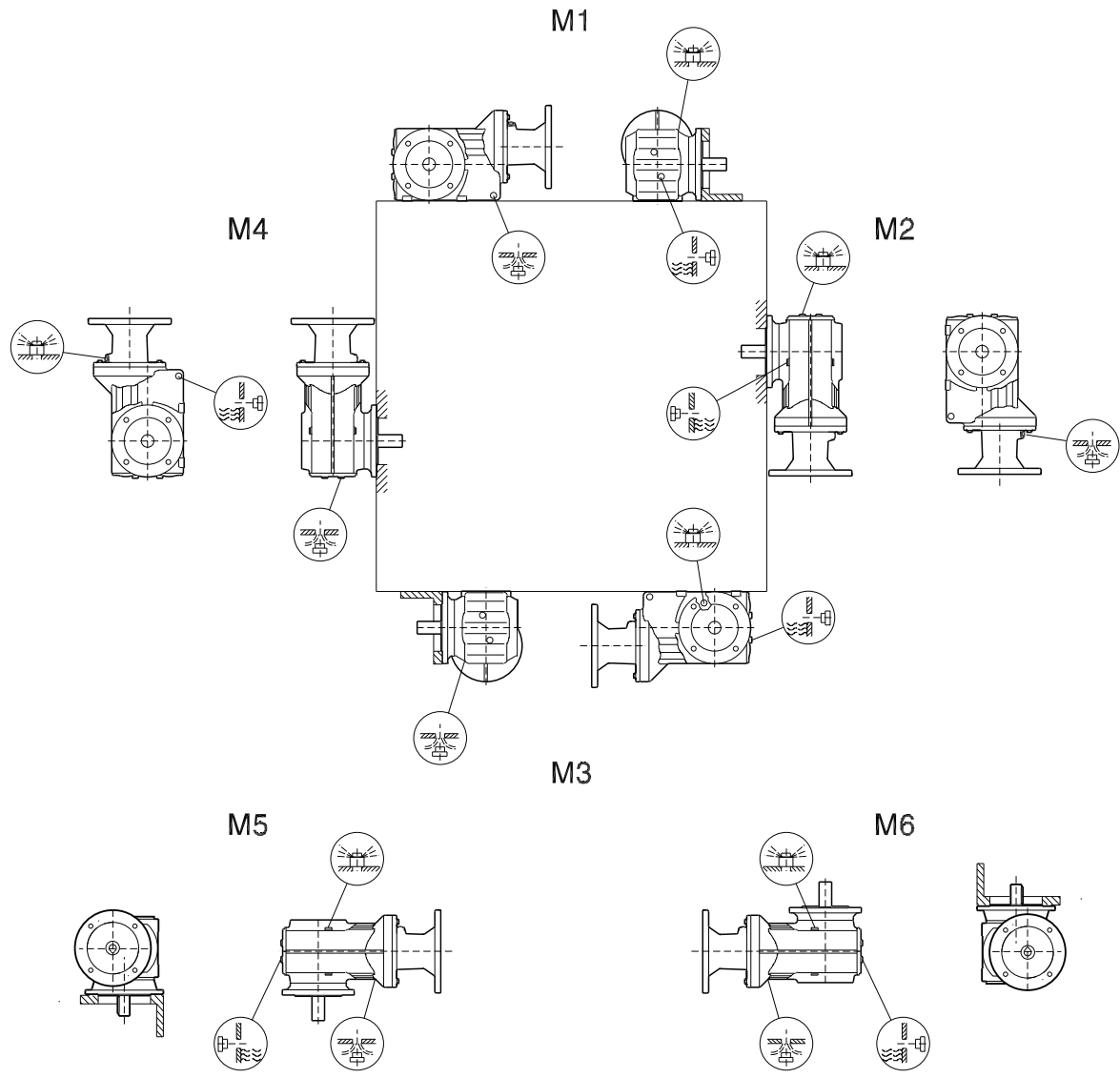
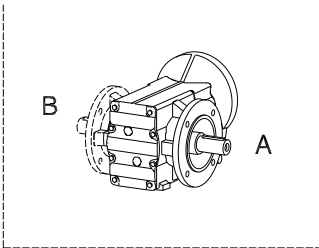

KA/KT39-49

33 094 00 10

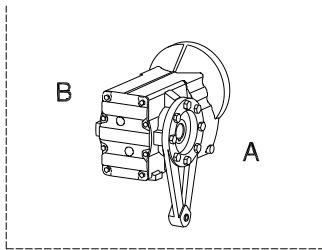

5

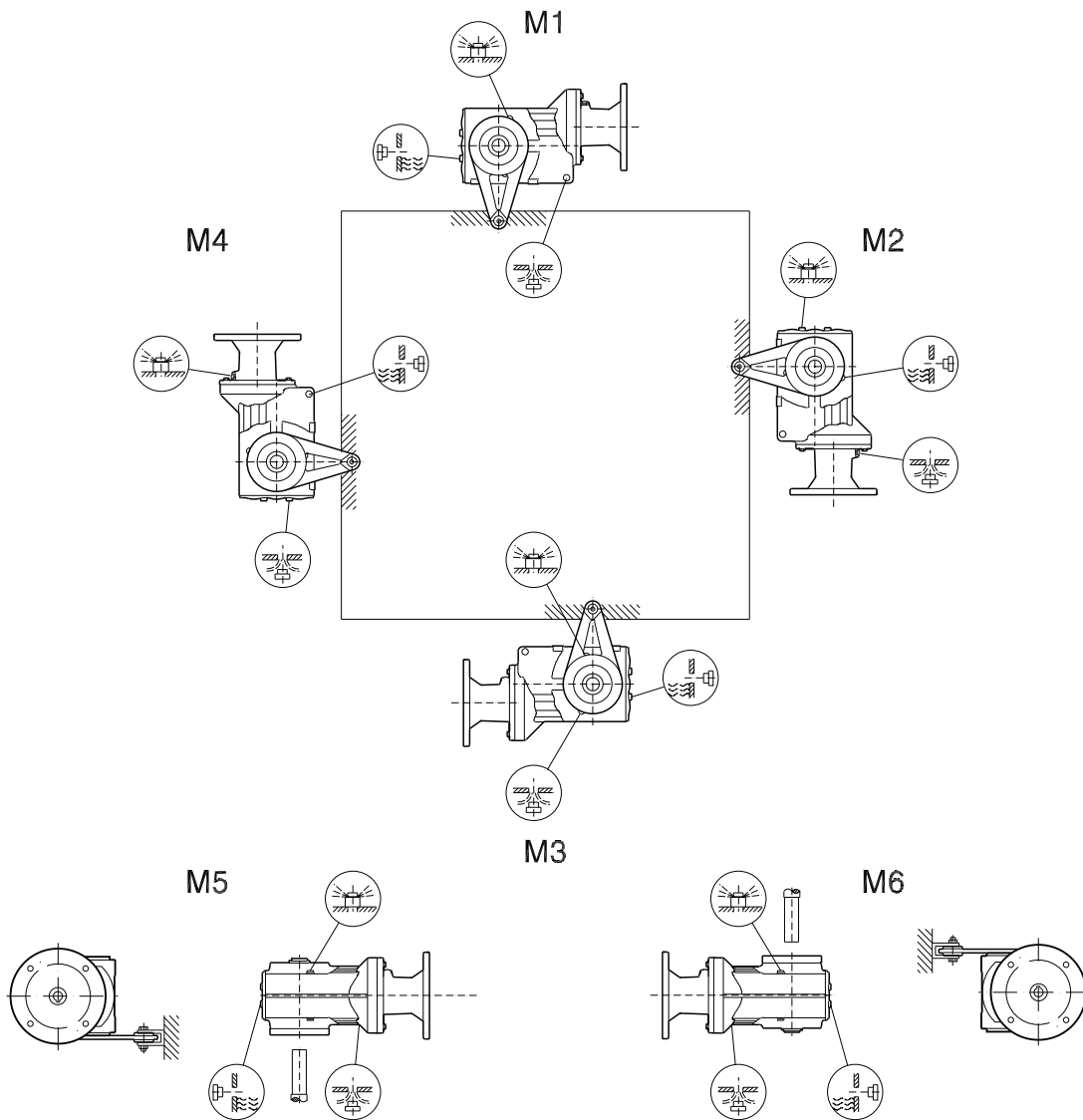

5 Mounting Positions

K-series helical-bevel

K/KA..B/KH37B-157B, KV37B-107B

33 001 00 10

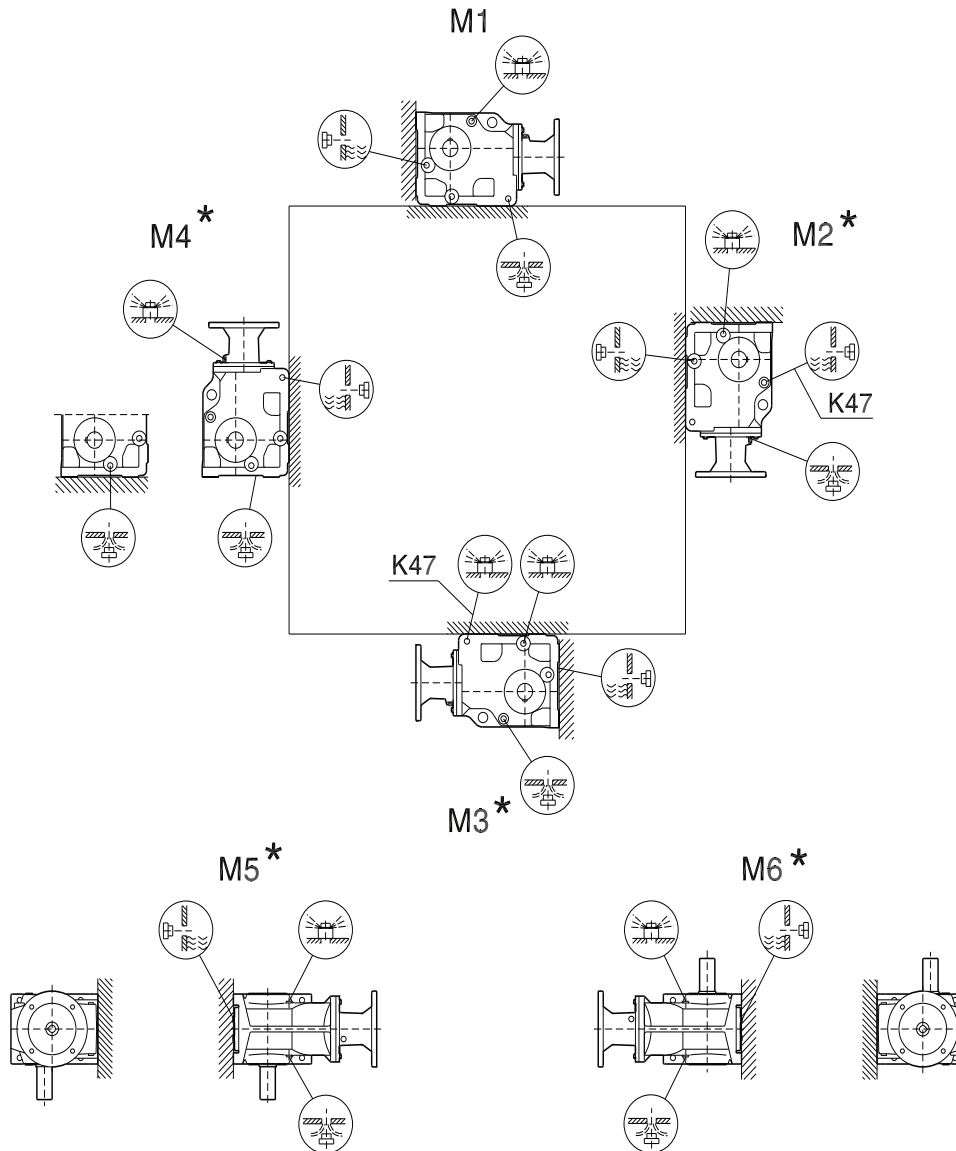

* → page 45 on thermal losses

Important:

Proper alignment must be ensured when mounting a hollowshaft gear unit with feet. See Technical Note **GM-019** available from www.seweurodrive.com

K/KH167B-187B

33 002 00 10

5

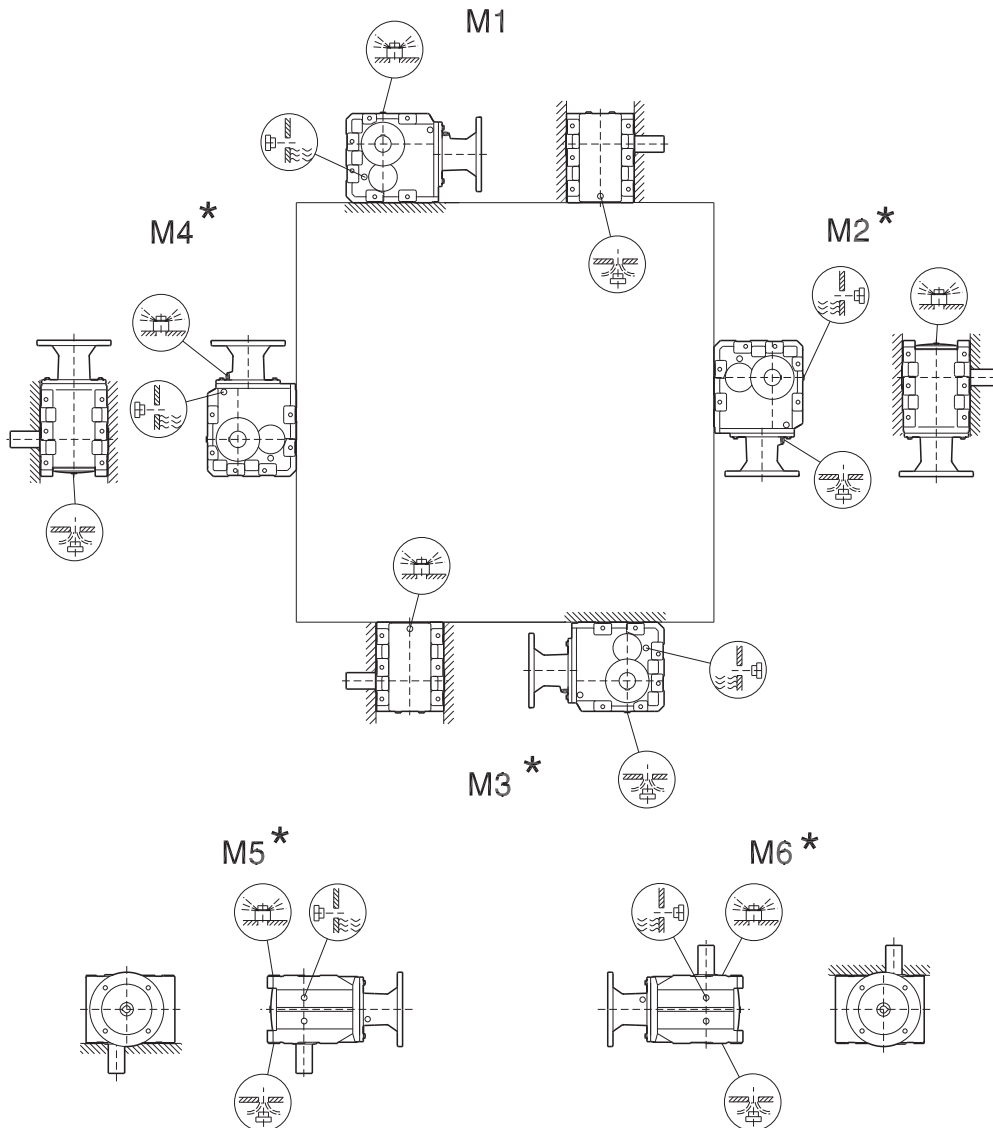

* → page 45 on thermal losses

Important:

Proper alignment must be ensured when mounting a hollowshaft gear unit with feet. See Technical Note **GM-019** available from www.seweurodrive.com

The hatched surface shown is the only surface that should be used for M5 and M6 mounting.

The OHL, Fra, shown in the selection tables is reduced 50% or more if the gear unit is mounted via a surface other than the one shown above for M1 to M4.

5 Mounting Positions

K-series helical-bevel

KF/KAF/KHF/KAZ/KHZ37-157, KVF/KVZ37-107

33 003 00 10

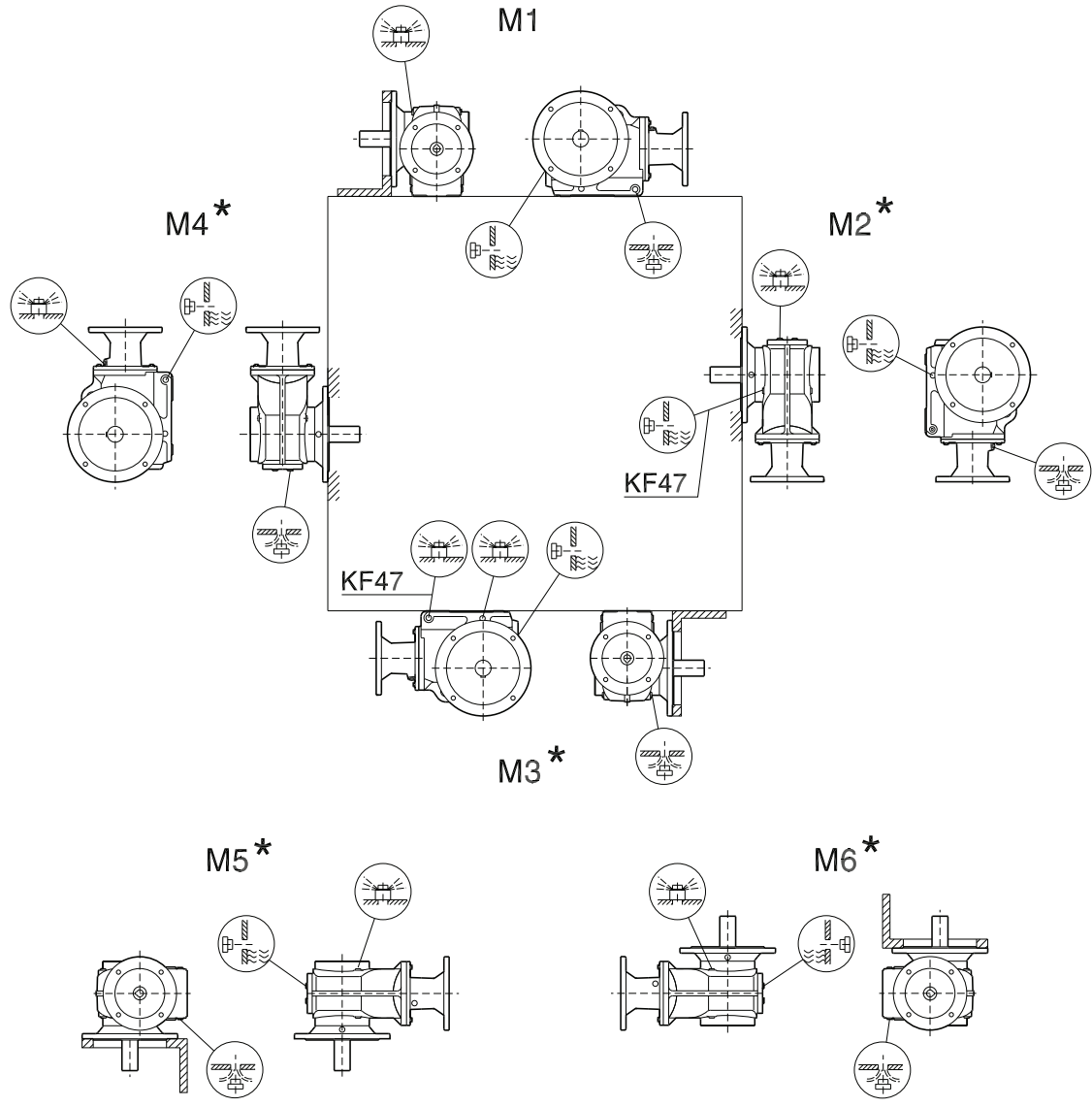

* → page 45 on thermal losses

KA/KH37-157, KV37-107, KT37-97

33 004 00 10

5

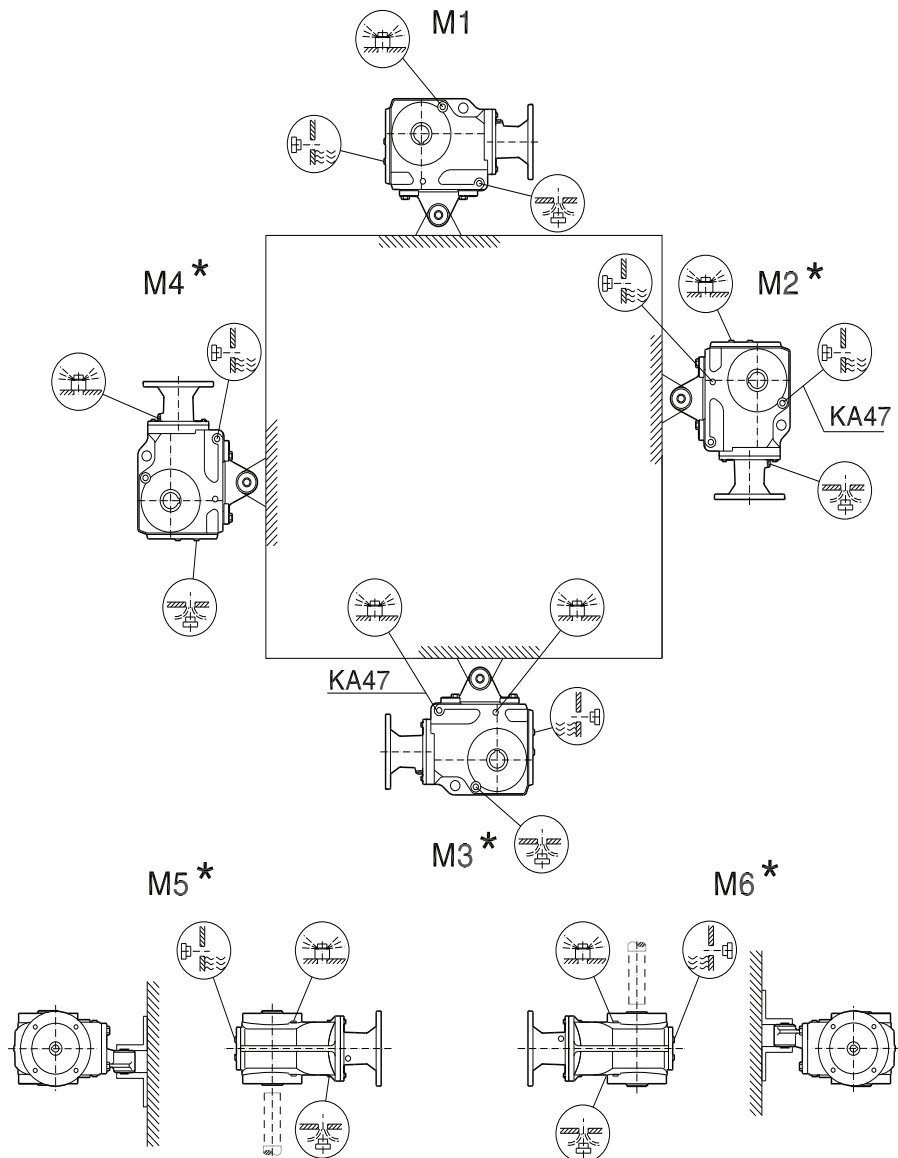

* → page 45 on thermal losses

Important:

For proper torque arm mounting and design, see Technical Note **GM-021** available from www.seweurodrive.com

5 Mounting Positions

K-series helical-bevel

KH167-187

33 005 00 10

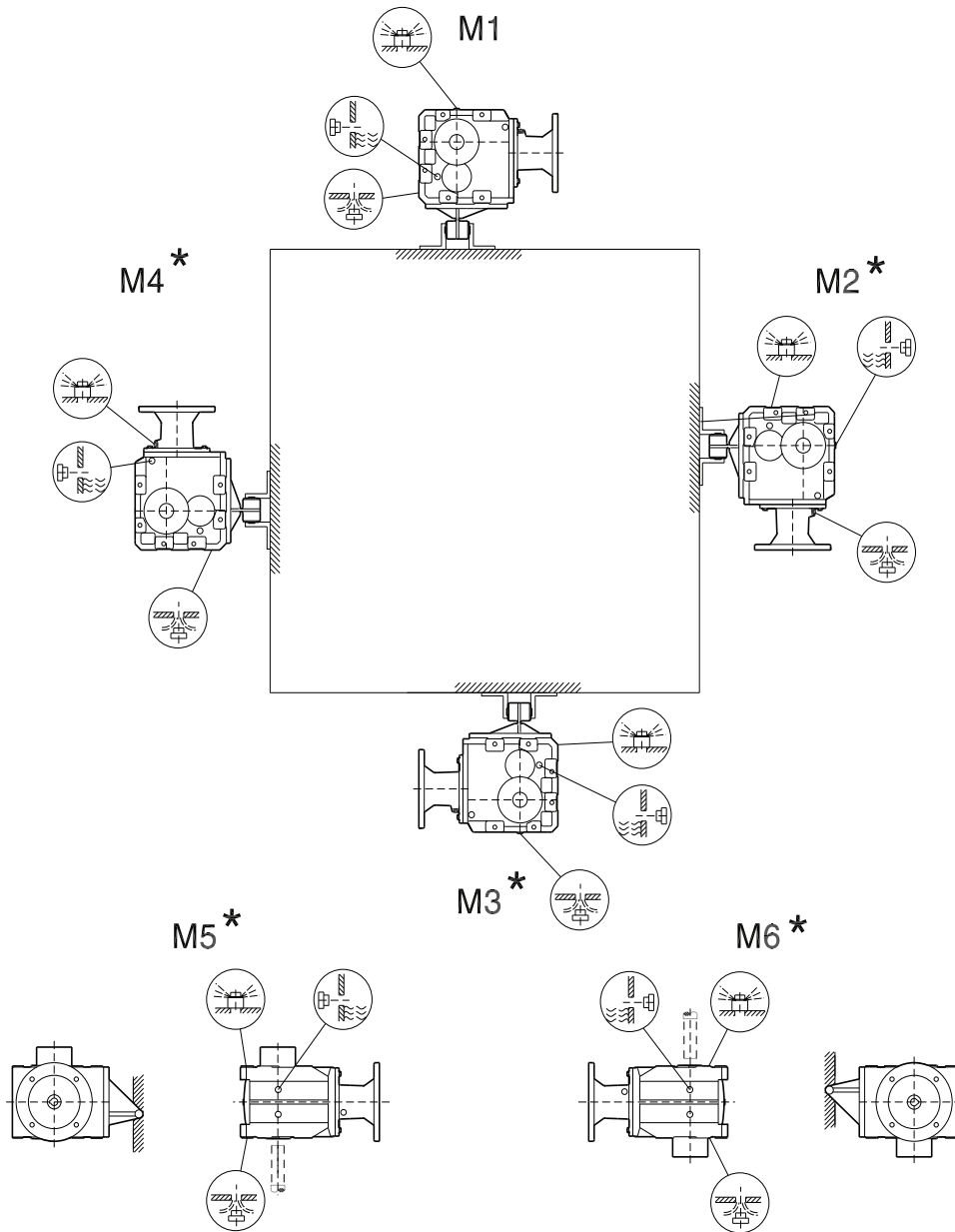

* → page 45 on thermal losses

Important:

For proper torque arm mounting and design, see Technical Note **GM-021** available from www.seweurodrive.com

5.5 S-series helical-worm

S37

02 001 00 10

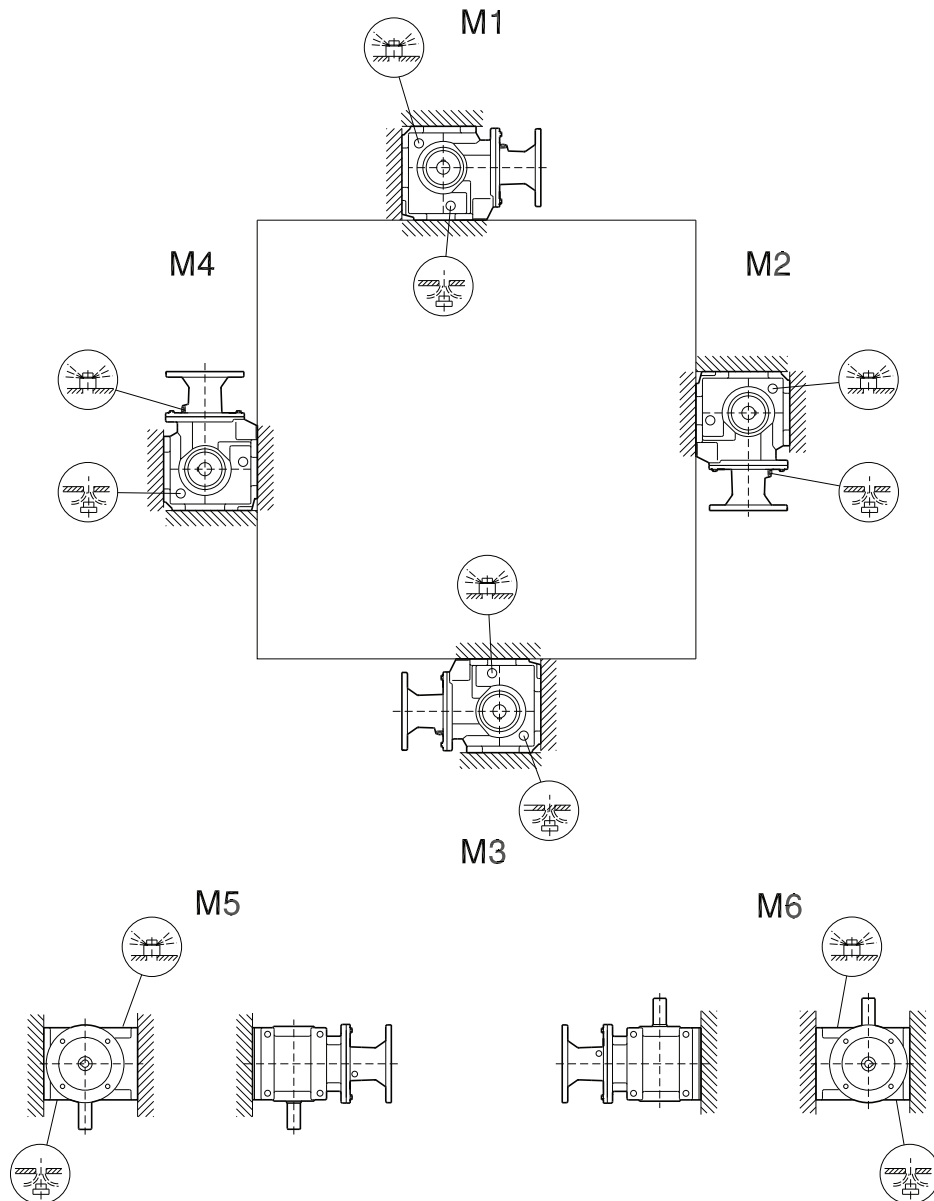

5

Important: Proper alignment must be ensured when two mounting surfaces are used.

5 Mounting Positions

S-series helical-worm

S47-S97

02 002 00 10

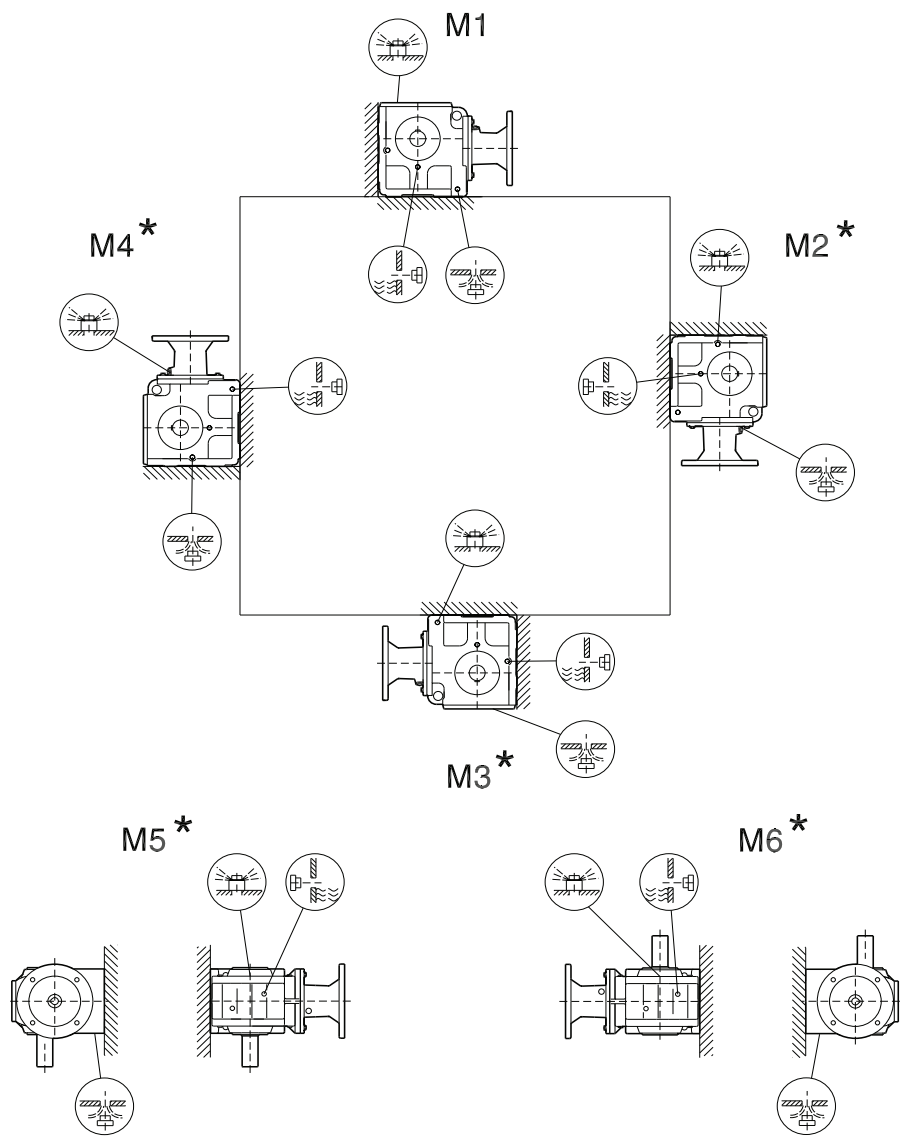

* → page 45 on thermal losses

Important: Proper alignment must be ensured when two mounting surfaces are used.

SF/SAF/SHF37

02 003 00 10

5

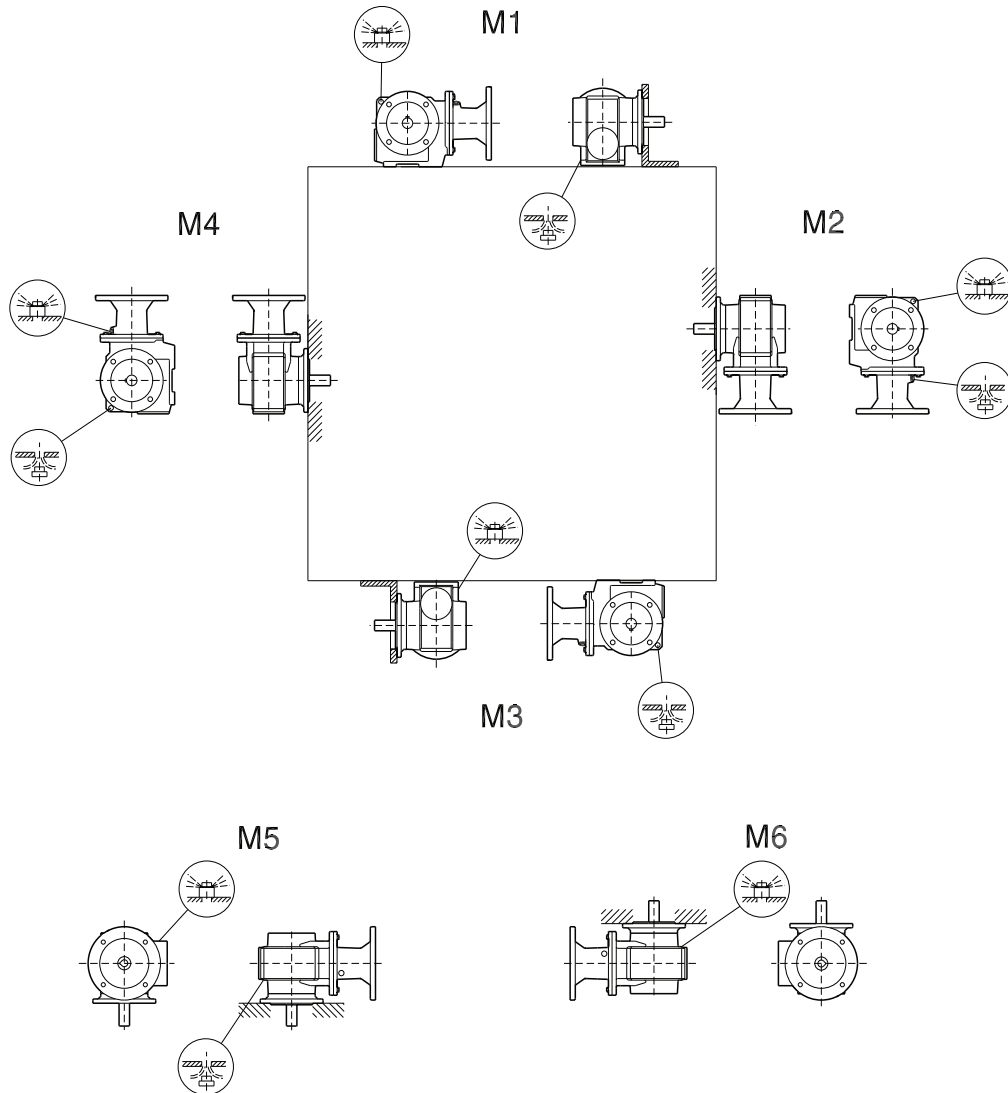

5 Mounting Positions

S-series helical-worm

SF/SAF/SHF/SAZ/SHZ47-97

02 004 00 10

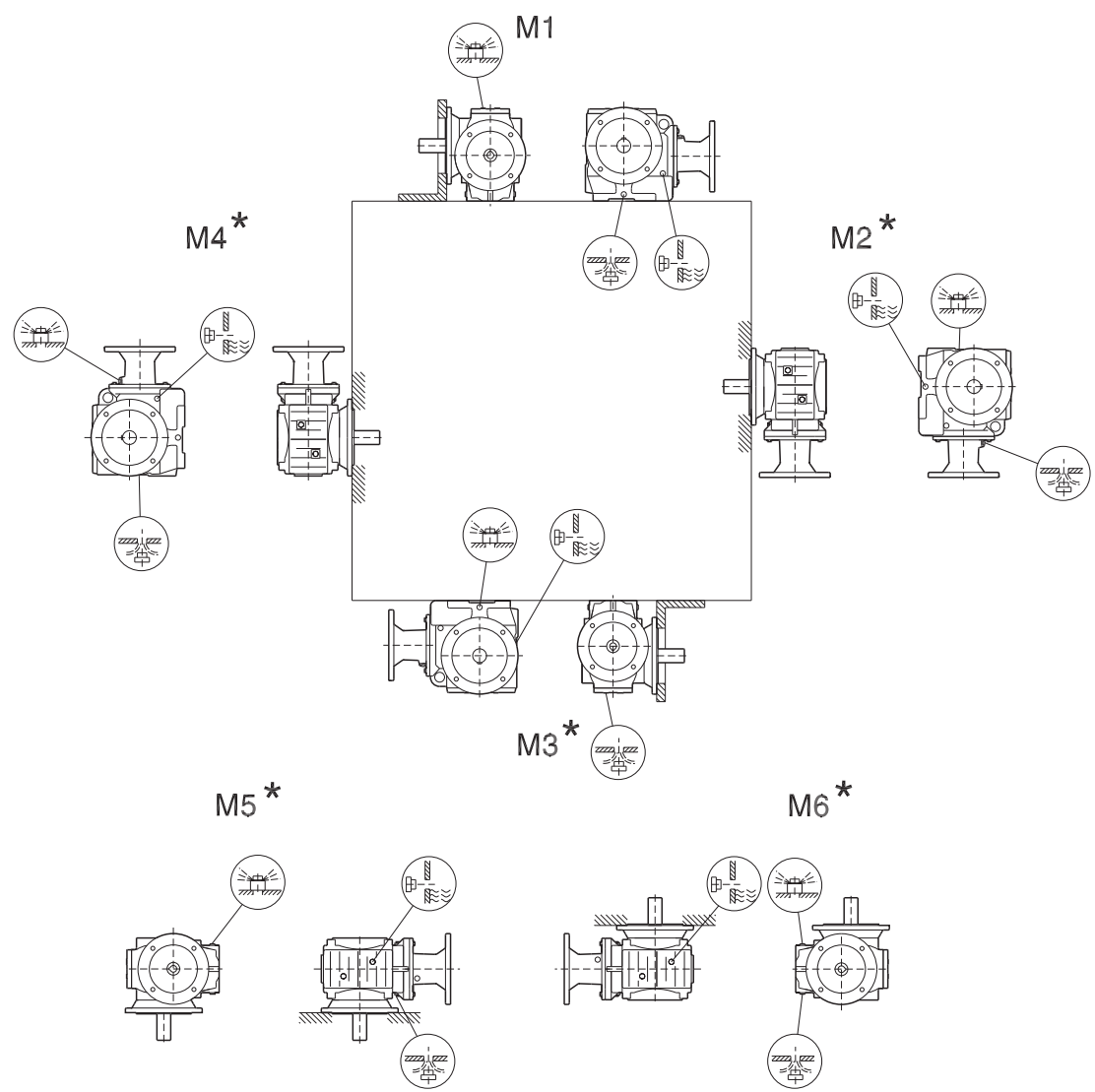

* → page 45 on thermal losses

SA/SH/ST37

02 005 00 10

5

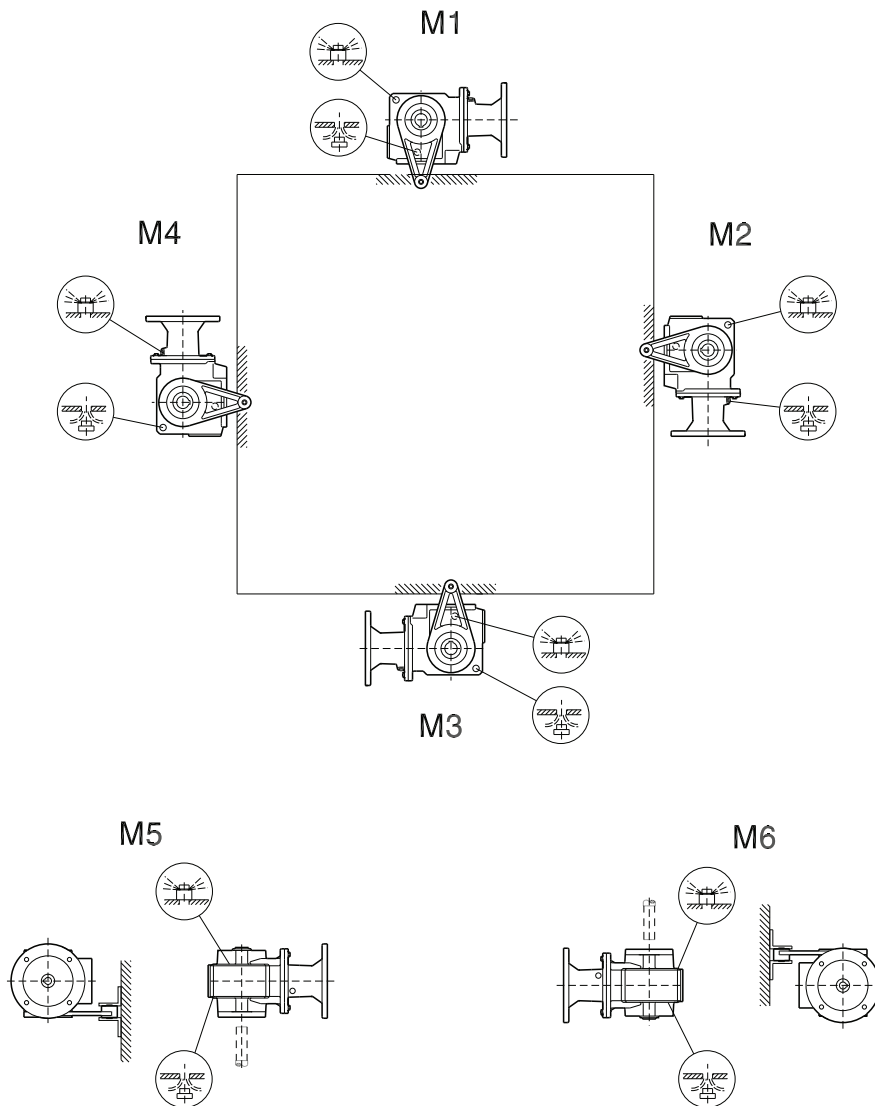

* → page 45 on thermal losses

Important:

For proper torque arm mounting and design, see Technical Note **GM-021** available from www.seweurodrive.com

5 Mounting Positions

S-series helical-worm

SA/SH/ST47-97

02 006 00 10

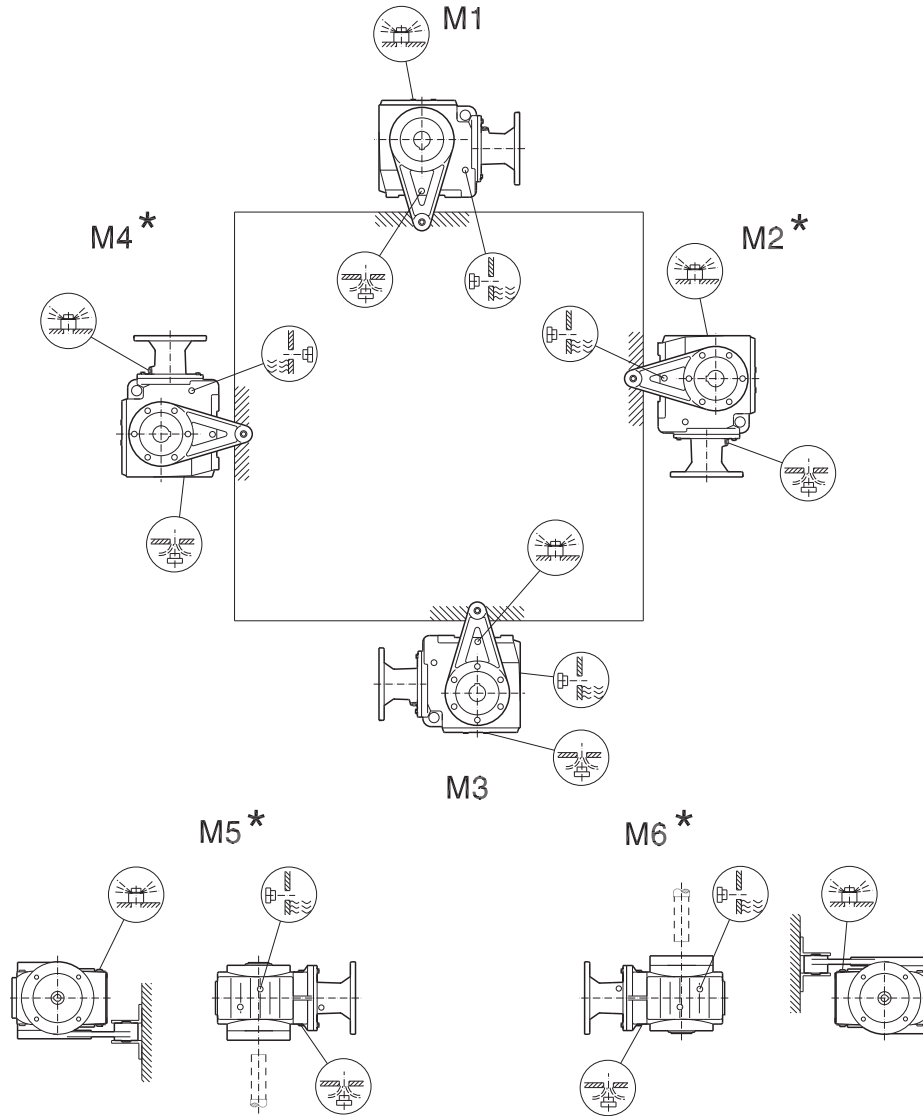

* → page 45 on thermal losses

Important:

For proper torque arm mounting and design, see Technical Note **GM-021** available from www.seweurodrive.com

5.6 SPIROPLAN®

W/WA..B/WH37B-47B

20 002 00 10

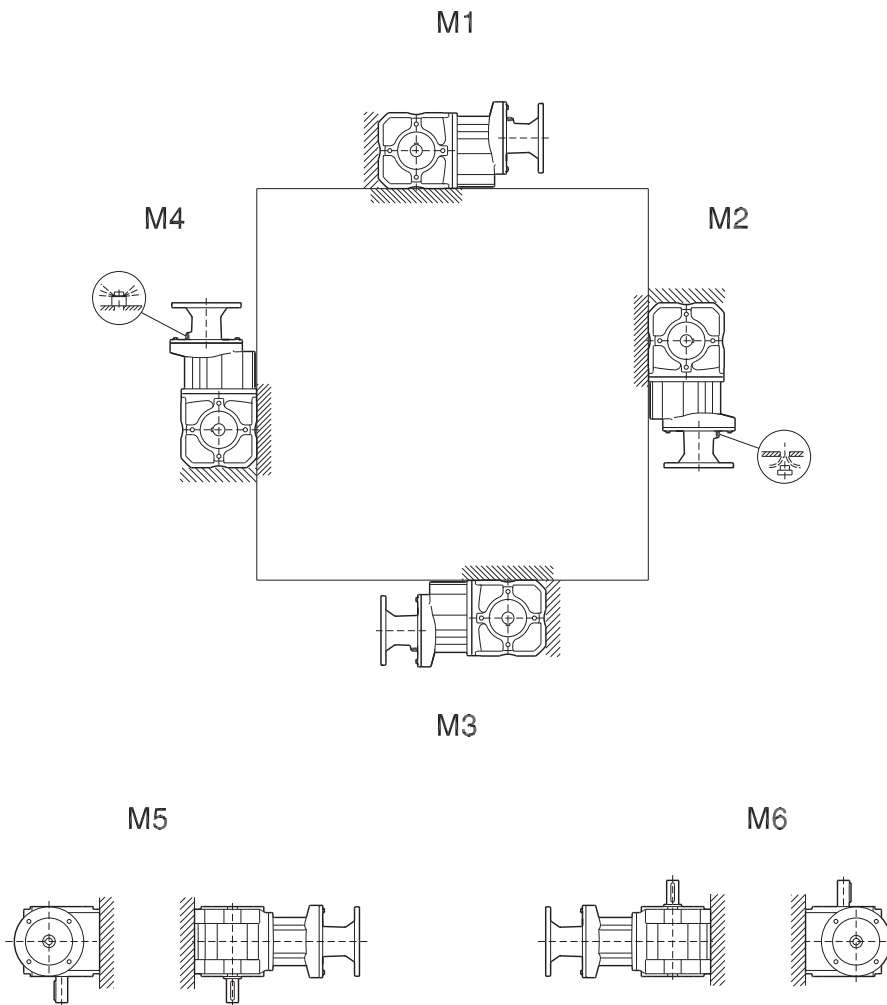

Important:

Proper alignment must be ensured when mounting a hollowshaft gear unit with feet. See Technical Note **GM-019** available from www.seweurodrive.com.

5 Mounting Positions

SPIROPLAN®

WF/WAF/WHF37-47

02 003 00 10

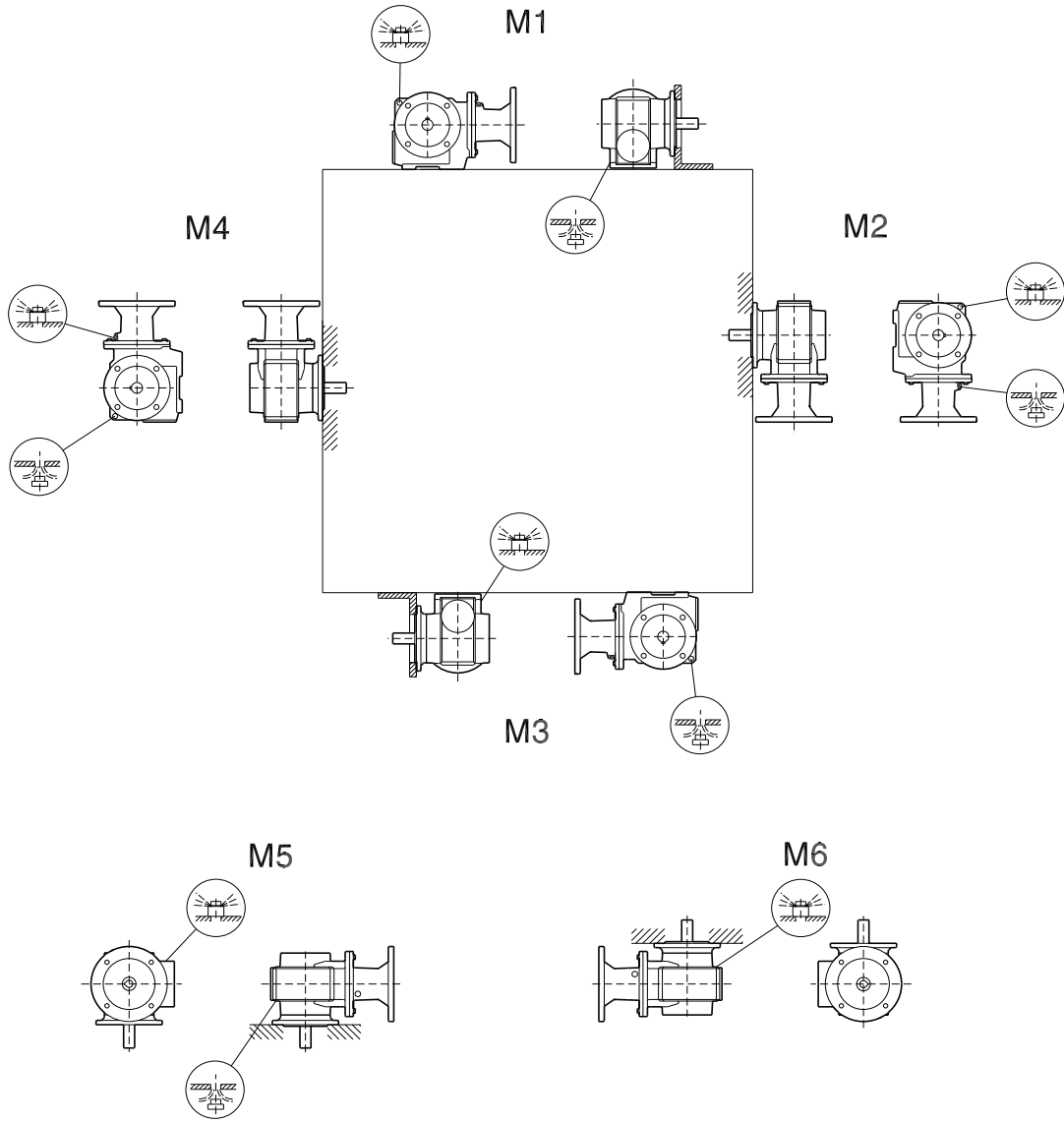

WA/WH/WT37-47

20 004 00 10

5

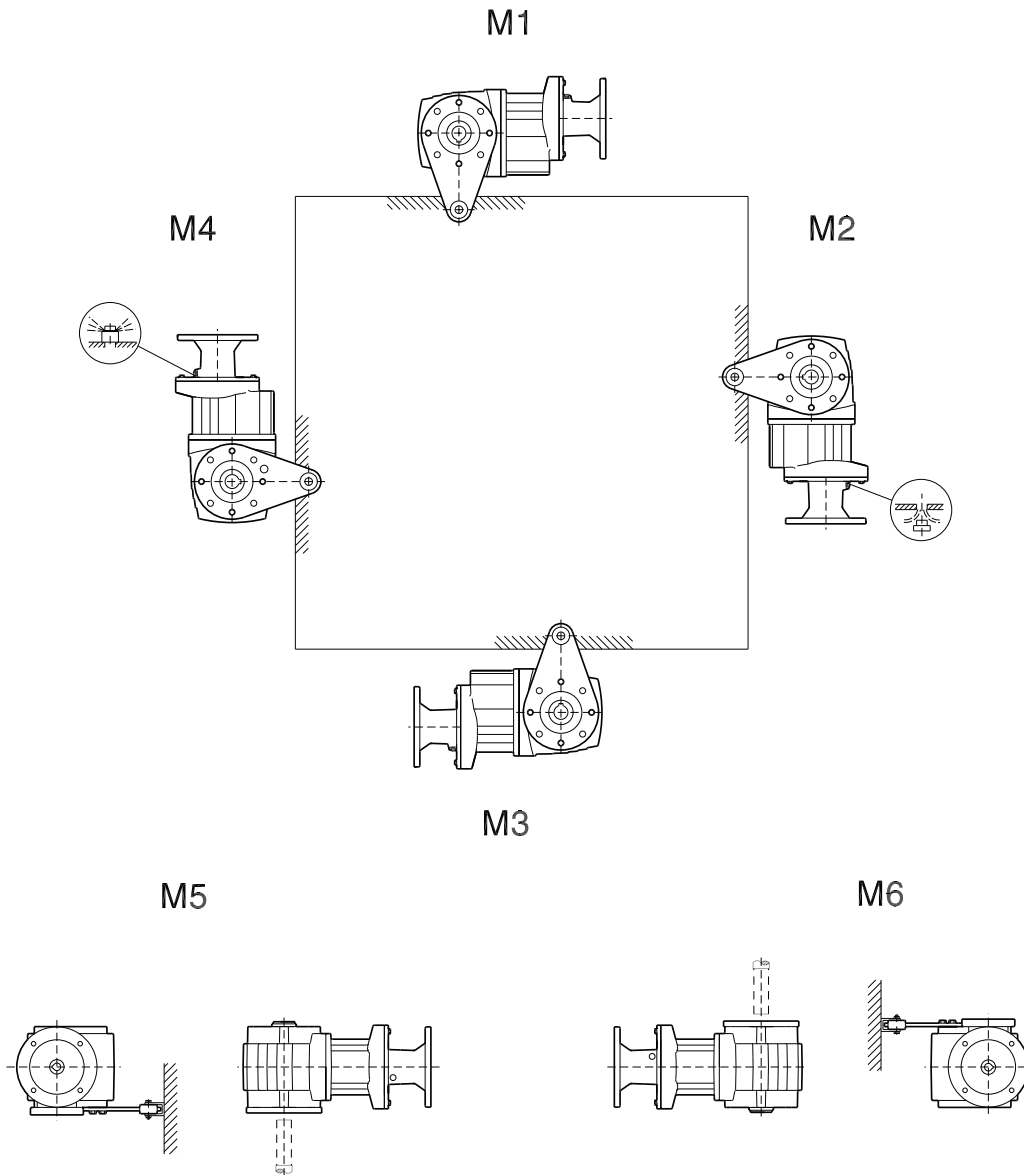

Important:

For proper torque arm mounting and design, see Technical Note **GM-021** available from www.seweurodrive.com

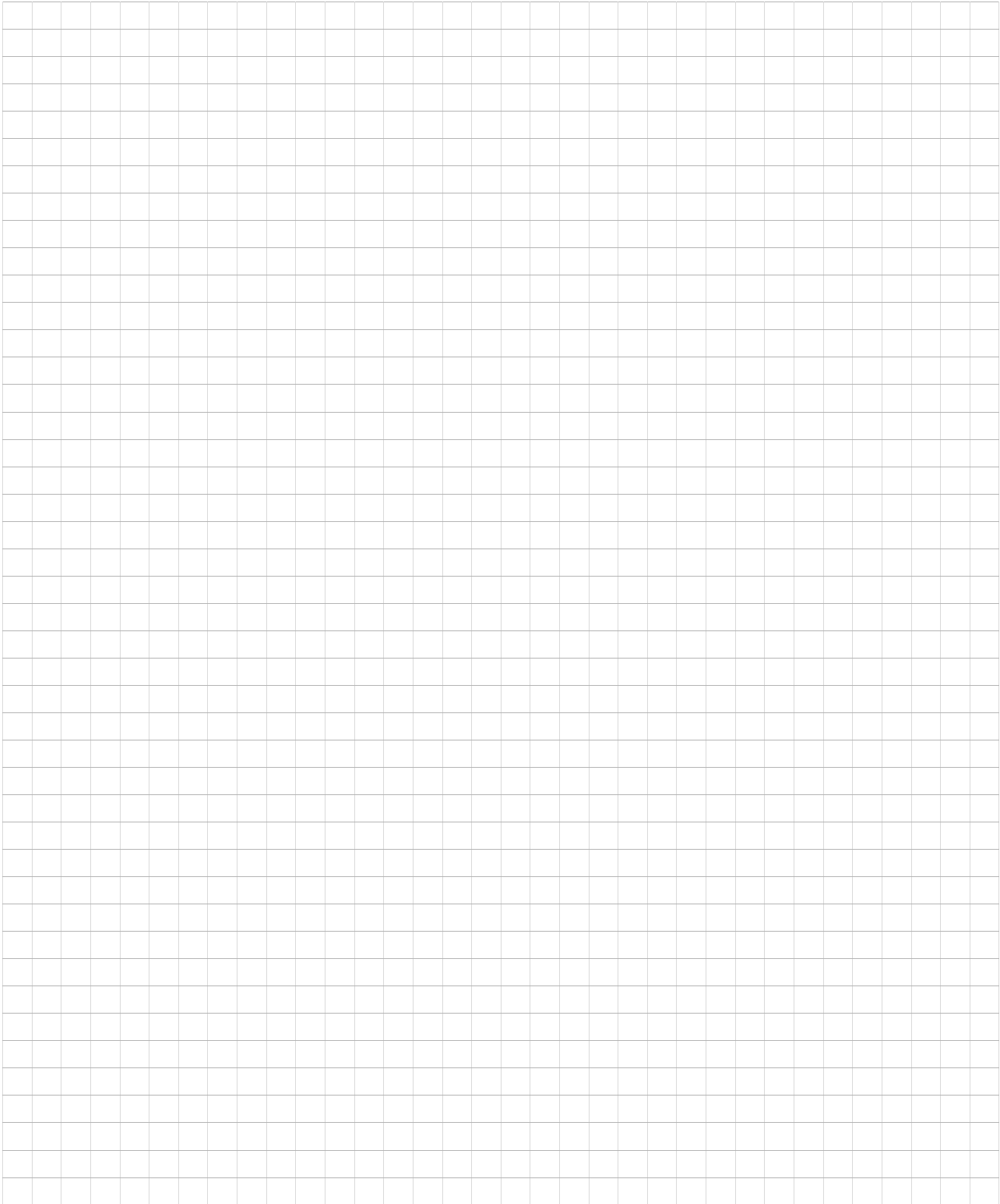



6 Lubrication

6.1 Greases and table keys

SEW-EURODRIVE supplies drives with the proper amount of oil specific to the gear unit and mounting position. If you later change the position, you will have to change the amount of oil within the gear unit. See fill quantities beginning on page 103.

Greases

The anti-friction bearings in gear units and motors are given a factory-fill with the greases listed below. SEW-EURODRIVE recommends regreasing bearings at the same time as changing the oil or replacing the bearings.

	Type	Ambient temperature	Manufacturer	Brand Name
Gear unit bearings	mineral	-20 °C ... +60 °C	Shell	Gadus S2 V220 2
	synthetic	-40 °C ... +80 °C	Shell	Gadus S5 V100 2
		-20 °C ... +40 °C	Klüber	Klübersynth UH1 14-151
		-20 °C ... +40 °C	Klüber	Klüberbio M 72-82
Motor bearings	mineral	-20 °C ... +80 °C	ExxonMobil	Polyrex EM
	synthetic	-40 °C ... +60 °C	Kyodo Yushi	Multemp SRL







INFORMATION	
	The following grease quantities are required:
	<ul style="list-style-type: none"> • For fast-running bearings (gear unit input end): Fill the cavities between the rolling elements one-third full with grease. • For slow-running bearings (in gear units and at gear unit output end): Fill the cavities between the rolling elements two-thirds full with grease.

Table keys

















The lubricant table on the following page shows the permissible lubricants for SEW-EURODRIVE gear units. Observe the following key to the table.

- API GL-5 = American Petroleum Institute GL-5 type oil
- CLP (CC) = Mineral oil
- CLP PG = Synthetic: polyglycol
- CLP HC = Synthetic: hydrocarbon
- E = Ester oil (water pollution danger category WGK1)
- GP = Mineral grease for enclosed gears
- GP HC = Synthetic grease for enclosed gears
- SEW PG = Synthetic: polyglycol, special SEW formulation
-  = Synthetic lubricant or synthetic bearing grease
-  = Mineral lubricant or mineral bearing grease
- 1) Helical-worm gear units with PG oil: please contact SEW-EURODRIVE
- 2) Special lubricant for SPIROPLAN® gear units only
- 3) Gear unit service factor, $SEW-f_B \geq 1.2$ required
- 4) Observe the starting behavior at low temperatures
- 5) Low-viscosity grease
-  Lubricant for the food industry (food grade oil)
-  Biodegradable oil (lubricant for agriculture, forestry, fisheries, and water management)
-  Available at all SEW (USA) facilities

















6.2 Lubricant tables

The following tables show the assignment of lubricants to gear units:

01 751 09 04 US1

	Ambient Temperature				Note	DIN (ISO) API	ISO, SAE NLGI	Mobil®	Shell	bp	KLOBER LUBRICATION	TEXACO
	-50	0°C	+50	+100								
R.. 	-15	Standard	+40			CLP (CC)	VG 220	Mobilgear 600 XP 220	Shell Omala S2 G 220	BP Energol GR-XP 220	Klüberoil GEM 1-220 N	Meropa 220
	-20		+80			CLP PG	VG 220	Mobil Glygoyle 220	Shell Omala S4 WE 220	BP Enersyn SG-XP 220	Klübersynth GH 6-220	Synlube CLP 220
K..7 (HK..) 	-20		+60			CLP HC	VG 220	Mobil SHC 630	Shell Omala S4 GX 220		Klübersynth GEM 4-220 N	Pinnacle EP 220
	-40		+40				VG 150	Mobil SHC 629	Shell Omala S4 GX 150		Klübersynth GEM 4-150 N	Pinnacle EP 150
F.. 	-20		+25			CLP (CC)	VG 150	Mobilgear 600 XP 150	Shell Omala S2 G 150	BP Energol GR-XP 150	Klüberoil GEM 1-150 N	Meropa 150
	-4		+20			CLP HC	VG 68	Mobil SHC 626	Shell Morlina S4 B 68			
	-40	0					VG 32	Mobil SHC 624	Shell Corena S4 R 32		Klüber-Summit HySyn FG-32	Cetus PAO 46
K..9 	-20	Standard	+60			CLP PG	VG 460				Klübersynth GH 6-460	
	-20		+60			CLP PG 	VG 460				Klübersynth UH1 6-460	
S.. (HS..) 	0	Standard	+40			CLP (CC)	VG 680	Mobilgear 600 XP 680	Shell Omala S2 G 680	BP Energol GR-XP 680	Klüberoil GEM 1-680 N	Meropa 680
	-20		+80		1)	CLP PG	VG 680	Mobil Glygoyle 680	Shell Omala S4 WE 680	BP Enersyn SG-XP 680	Klübersynth GH 6-680	Synlube CLP 680
	-20		+60			CLP HC	VG 460	Mobil SHC 634	Shell Omala S4 GX 460		Klübersynth GEM 4-460 N	Pinnacle EP 460
	-40		+30		4)		VG 150	Mobil SHC 629	Shell Omala S4 GX 150		Klübersynth GEM 4-150 N	Pinnacle EP 150
	-20	+10				CLP (CC)	VG 150	Mobilgear 600 XP 150	Shell Omala S2 G 150	BP Energol GR-XP 150	Klüberoil GEM 1-150 N	Meropa 150
	-20		+40		1)	CLP PG	VG 220	Mobil Glygoyle 220	Shell Omala S4 WE 220	BP Enersyn SG-XP 220	Klübersynth GH 6-220	Synlube CLP 220
	-40		+20			CLP HC	VG 68	Mobil SHC 626	Shell Morlina S4 B 68			
	-40	0					VG 32	Mobil SHC 624	Shell Corena S4 R 32		Klüber-Summit HySyn FG-32	Cetus PAO 46
R.., K.., F..	-20		+60			CLP PG 	VG 460				Klübersynth UH1 6-460	
R.., K.., F.., S..	-10	Standard	+40			CLP HC	VG 460				Klüberöl 4UH1-460 N	
	-20		+30				VG 220				Klüberöl 4UH1-220 N	
	-40	0					VG 68				Klüberöl 4UH1-68 N	
	-20		+40			E 	VG 460				Klüberbio CA2-460	
W.. (HW..) 	-20	Standard	+40		2)	SEW PG	VG 460				Klüber SEW HT-460-5	
	-40		+10		4)	API GL5	SAE 75W90 (~VG 100)	Mobil Synth Gear Oil 75 W90				
	-20		+60		3)	CLP PG 	VG 460				Klübersynth UH1 6-460	
PS F 	-20	Standard	+80			CLP PG	VG 220				Klübersynth GH 6-220	
	-20		+60		3)	CLP PG 	VG 460				Klübersynth UH1 6-460	
	-40	0				CLP HC	VG 32	Mobil SHC 624	Shell Corena S4 R 32			
PS C 	-10	Standard	+40			CLP (CC)	VG 220	Mobilgear 600 XP 220	Shell Omala S2 G 220			
	-20		+40		5)	GP	NLGI 00 VG 160	Mobilux EP 004				
	-20		+40		5)	GP HC 	NLGI 1 VG 150				Klübersynth UH1 14-151	
	-40	0				CLP HC	VG 32	Mobil SHC 624	Shell Corena S4 R 32			
BS F 	-20	Standard	+60			CLP PG	VG 220				Klübersynth GH 6-220	
	-20		+60		3)	CLP PG 	VG 460				Klübersynth UH1 6-460	

01 751 09 04 US2

	Ambient Temperature				Note	DIN (ISO) API	ISO, SAE NLGI	Castrol		FUCHS	TOTAL
	-50	0°C	+50	+100				Tribol	Optimol		
	-15	Standard	+40			CLP (CC)	VG 220	Tribol 1100/220	Optigear BM 220	Renolin CLP 220	Carter EP 220
	-20		+80			CLP PG	VG 220	Tribol 800/220	Optiflex A 220	Renolin PG 220	Carter SY 220
	-20		+60			CLP HC	VG 220	Tribol 1510/220	Optigear Synthetic X 220	Renolin Unisyn CLP 220	Carter SH 220
	-40		+40				VG 150		Optigear Synthetic X 150	Renolin Unisyn CLP 150	Carter SH 150
	-20		+25			CLP (CC)	VG 150	Tribol 1100/150	Optigear BM 150	Renolin CLP 150	Carter EP 150
	-40		+20			CLP HC	VG 68			Renolin Unisyn CLP 68	
	-40	0					VG 32		Optileb HY 32	Renolin Unisyn OL32	Dacnis SH 32
	-20	Standard	+60			CLP PG	VG 460				
	-20		+60			CLP PG 	VG 460				
	0	Standard	+40			CLP (CC)	VG 680	Tribol 1100/680	Optigear BM 680	Renolin SEW 680	Carter EP 680
	-20		+80		1)	CLP PG	VG 680	Tribol 800/680	Optiflex A 680	Renolin PG 680	
	-20		+60			CLP HC	VG 460		Optigear Synthetic X 460	Renolin Unisyn CLP 460	Carter SH 460
	-40		+30		4)		VG 150		Optigear Synthetic X 150	Renolin Unisyn CLP 150	Carter SH 150
	-20		+10			CLP (CC)	VG 150	Tribol 1100/150	Optigear BM 150	Renolin CLP 150	Carter EP 150
	-20		+40		1)	CLP PG	VG 220	Tribol 800/220	Optiflex A 220	Renolin PG 220	Carter SY 220
	-40		+20			CLP HC	VG 68			Renolin Unisyn CLP 68	
	-40	0					VG 32		Alphasyn T 32	Renolin Unisyn OL32	Dacnis SH 32
R.. K.., F..	-20		+60			CLP PG 	VG 460				
R.. K.. F.. S..	-10	Standard	+40			CLP HC	VG 460		Optileb GT 460	Cassida Fluid GL 460	
	-20		+30				VG 220		Optileb GT 220	Cassida Fluid GL 220	
	-40	0					VG 68		Optileb HY 68	Cassida Fluid HF 68	
	-20		+40			E 	VG 460			Plantogear 460 S	
	-20	Standard	+40		2)	SEW PG	VG 460				
	-40		+10		4)	API GL5	SAE 75W90 (-VG 100)				
	-20		+60		3)	CLP PG 	VG 460				
PS F 	-20	Standard	+80			CLP PG	VG 220				
	-20		+60		3)	CLP PG 	VG 460				
	-40	0				CLP HC	VG 32				
PS C 	-10	Standard	+40			CLP (CC)	VG 220				
	-20		+40		5)	GP	NLGI 00 VG 160				
	-20		+40		5)	GP HC 	NLGI 1 VG 150				
	-40	0				CLP HC	VG 32				
	-20	Standard	+60			CLP PG	VG 220				
	-20		+60		3)	CLP PG 	VG 460				

6.3 Fill quantities

The specified fill quantities are **recommended values**. The precise values vary depending on the number of stages and gear ratio. When filling, it is essential to check the **oil level plug since it indicates the precise oil volume**.

The following tables show guide values for lubricant fill quantities in relation to the mounting position M1 - M6.

Helical (R) gear units

RX..

Gear unit	Fill quantity in liters					
	M1	M2	M3	M4	M5	M6
RX57	0.60	0.80	1.30	1.30	0.90	0.90
RX67	0.80	0.80	1.70	1.90	1.10	1.10
RX77	1.10	1.50	2.60	2.70	1.60	1.60
RX87	1.70	2.50	4.80	4.80	2.90	2.90
RX97	2.10	3.40	7.4	7.0	4.80	4.80
RX107	3.90	5.6	11.6	11.9	7.7	7.7

RXF..

Gear unit	Fill quantity in liters					
	M1	M2	M3	M4	M5	M6
RXF57	0.50	0.80	1.10	1.10	0.70	0.70
RXF67	0.70	0.80	1.50	1.40	1.00	1.00
RXF77	0.90	1.30	2.40	2.00	1.60	1.60
RXF87	1.60	1.95	4.90	3.95	2.90	2.90
RXF97	2.10	3.70	7.1	6.3	4.80	4.80
RXF107	3.10	5.7	11.2	9.3	7.2	7.2

R..., R..F

Gear unit	Fill quantity in liters					
	M1 ¹⁾	M2 ¹⁾	M3	M4	M5	M6
R07	0.12	0.20	0.20	0.20	0.20	0.20
R17	0.25	0.55	0.35	0.55	0.35	0.40
R27	0.25/0.40	0.70	0.50	0.70	0.50	0.50
R37	0.30/0.95	0.85	0.95	1.05	0.75	0.95
R47	0.70/1.50	1.60	1.50	1.65	1.50	1.50
R57	0.80/1.70	1.90	1.70	2.10	1.70	1.70
R67	1.10/2.30	2.40/3.20	2.80	2.90	1.80	2.00
R77	1.20/3.00	3.30/4.20	3.60	3.80	2.50	3.40
R87	2.30/6.0	6.4/8.1	7.2	7.2	6.3	6.5
R97	4.60/9.8	11.7/14.0	11.7	13.4	11.3	11.7
R107	6.0/13.7	16.3	16.9	19.2	13.2	15.9
R137	10.0/25.0	28.0	29.5	31.5	25.0	25.0
R147	15.4/40.0	46.5	48.0	52.0	39.5	41.0
R167	27.0/70.0	82.0	78.0	88.0	66.0	69.0

1) The larger gear unit requires a larger volume when there is a compound gear unit (ex: R67R37).

RF..

Gear unit	Fill quantity in liters					
	M1 ¹⁾	M2 ¹⁾	M3	M4	M5	M6
RF07	0.12	0.20	0.20	0.20	0.20	0.20
RF17	0.25	0.55	0.35	0.55	0.35	0.40
RF27	0.25/0.40	0.70	0.50	0.70	0.50	0.50
RF37	0.35/0.95	0.90	0.95	1.05	0.75	0.95
RF47	0.65/1.50	1.60	1.50	1.65	1.50	1.50
RF57	0.80/1.70	1.80	1.70	2.00	1.70	1.70
RF67	1.20/2.50	2.50/3.20	2.70	2.80	1.90	2.10
RF77	1.20/2.60	3.10/4.10	3.30	3.60	2.40	3.00
RF87	2.40/6.0	6.4/8.2	7.1	7.2	6.3	6.4
RF97	5.1/10.2	11.9/14.0	11.2	14.0	11.2	11.8
RF107	6.3/14.9	15.9	17.0	19.2	13.1	15.9
RF137	9.5/25.0	27.0	29.0	32.5	25.0	25.0
RF147	16.4/42.0	47.0	48.0	52.0	42.0	42.0
RF167	26.0/70.0	82.0	78.0	88.0	65.0	71.0

1) The larger gear unit requires a larger volume when there is a compound gear unit (ex: RF67R37).

Parallel shaft
helical (F) gear
units

F..., FA..B, FH..B, FV..B

Gear unit	Fill quantity in liters					
	M1	M2	M3	M4	M5	M6
F..27	0.60	0.80	0.65	0.70	0.60	0.60
F..37	0.95	1.25	0.70	1.25	1.00	1.10
F..47	1.50	1.80	1.10	1.90	1.50	1.70
F..57	2.60	3.50	2.10	3.50	2.80	2.90
F..67	2.70	3.80	1.90	3.80	2.90	3.20
F..77	5.9	7.3	4.30	8.0	6.0	6.3
F..87	10.8	13.0	7.7	13.8	10.8	11.0
F..97	18.5	22.5	12.6	25.2	18.5	20.0
F..107	24.5	32.0	19.5	37.5	27.0	27.0
F..127	40.5	54.5	34.0	61.0	46.3	47.0
F..157	69.0	104.0	63.0	105.0	86.0	78.0

FF..

Gear unit	Fill quantity in liters					
	M1	M2	M3	M4	M5	M6
FF27	0.60	0.80	0.65	0.70	0.60	0.60
FF37	1.00	1.25	0.70	1.30	1.00	1.10
FF47	1.60	1.85	1.10	1.90	1.50	1.70
FF57	2.80	3.50	2.10	3.70	2.90	3.00
FF67	2.70	3.80	1.90	3.80	2.90	3.20
FF77	5.9	7.3	4.30	8.1	6.0	6.3
FF87	10.8	13.2	7.8	14.1	11.0	11.2
FF97	19.0	22.5	12.6	25.6	18.9	20.5
FF107	25.5	32.0	19.5	38.5	27.5	28.0
FF127	41.5	55.5	34.0	63.0	46.3	49.0
FF157	72.0	105.0	64.0	106.0	87.0	79.0

FA.., FH.., FV.., FAF.., FAZ.., FHF.., FHZ.., FVF.., FVZ.., FT..

Gear unit	Fill quantity in liters					
	M1	M2	M3	M4	M5	M6
F..27	0.60	0.80	0.65	0.70	0.60	0.60
F..37	0.95	1.25	0.70	1.25	1.00	1.10
F..47	1.50	1.80	1.10	1.90	1.50	1.70
F..57	2.70	3.50	2.10	3.40	2.90	3.00
F..67	2.70	3.80	1.90	3.80	2.90	3.20
F..77	5.9	7.3	4.30	8.0	6.0	6.3
F..87	10.8	13.0	7.7	13.8	10.8	11.0
F..97	18.5	22.5	12.6	25.2	18.5	20.0
F..107	24.5	32.0	19.5	37.5	27.0	27.0
F..127	39.0	54.5	34.0	61.0	45.0	46.5
F..157	68.0	103.0	62.0	104.0	85.0	79.5

Helical-bevel (K)
gear units

K.., KA..B, KH..B, KV..B

Gear unit	Fill quantity in liters					
	M1	M2	M3	M4	M5	M6
K..19	0.40	0.40	0.40	0.45	0.40	0.40
K..29	0.70	0.70	0.70	0.85	0.70	0.70
K..37	0.50	1.00	1.00	1.25	0.95	0.95
K..39	0.86	1.65	1.55	2.15	1.55	1.30
K..47	0.80	1.30	1.50	2.00	1.60	1.60
K..49	1.65	3.35	2.80	4.20	3.15	2.75
K..57	1.10	2.20	2.20	2.80	2.30	2.10
K..67	1.10	2.40	2.60	3.45	2.60	2.60
K..77	2.20	4.10	4.40	5.8	4.20	4.40
K..87	3.70	8.0	8.7	10.9	8.0	8.0
K..97	7.0	14.0	15.7	20.0	15.7	15.5
K..107	10.0	21.0	25.5	33.5	24.0	24.0
K..127	21.0	41.5	44.0	54.0	40.0	41.0
K..157	31.0	62.0	65.0	90.0	58.0	62.0
K..167	33.0	95.0	105.0	123.0	85.0	84.0
K..187	53.0	152.0	167.0	200	143.0	143.0

KF..

Gear unit	Fill quantity in liters					
	M1	M2	M3	M4	M5	M6
KF19	0.40	0.40	0.40	0.45	0.4	0.4
KF29	0.70	0.70	0.70	0.85	0.70	0.70
KF37	0.50	1.10	1.10	1.50	1.00	1.00
KF39	0.86	1.65	1.55	2.15	1.55	1.30
KF47	0.80	1.30	1.70	2.20	1.60	1.60
KF49	1.65	3.35	2.80	4.20	3.15	2.75
KF57	1.20	2.20	2.40	3.15	2.50	2.30
KF67	1.10	2.40	2.80	3.70	2.70	2.70
KF77	2.10	4.10	4.40	5.9	4.50	4.50
KF87	3.70	8.2	9.0	11.9	8.4	8.4
KF97	7.0	14.7	17.3	21.5	15.7	16.5
KF107	10.0	21.8	25.8	35.1	25.2	25.2
KF127	21.0	41.5	46.0	55.0	41.0	41.0
KF157	31.0	66.0	69.0	92.0	62.0	62.0

KA..., KH..., KV..., KAF..., KHF..., KVF..., KAZ..., KHZ..., KVZ..., KT..

Gear unit	Fill quantity in liters					
	M1	M2	M3	M4	M5	M6
K..19	0.40	0.40	0.40	0.45	0.40	0.40
K..29	0.70	0.70	0.70	0.85	0.70	0.70
K..37	0.50	1.00	1.00	1.40	1.00	1.00
K..39	0.86	1.65	1.55	2.15	1.55	1.30
K..47	0.80	1.30	1.60	2.15	1.60	1.60
K..49	1.65	3.35	2.80	4.20	3.15	2.75
K..57	1.20	2.20	2.40	3.15	2.70	2.40
K..67	1.10	2.40	2.70	3.70	2.60	2.60
K..77	2.10	4.10	4.60	5.9	4.40	4.40
K..87	3.70	8.2	8.8	11.1	8.0	8.0
K..97	7.0	14.7	15.7	20.0	15.7	15.7
K..107	10.0	20.5	24.0	32.4	24.0	24.0
K..127	21.0	41.5	43.0	52.0	40.0	40.0
K..157	31.0	66.0	67.0	87.0	62.0	62.0

Helical-worm (S)
gear units

S

Gear unit	Fill quantity in liters					
	M1	M2	M3 ¹⁾	M4	M5	M6
S..37	0.25	0.40	0.50	0.55	0.40	0.40
S..47	0.35	0.80	0.70/0.90	1.00	0.80	0.80
S..57	0.50	1.20	1.00/1.20	1.45	1.30	1.30
S..67	1.00	2.00	2.20/3.10	3.10	2.60	2.60
S..77	1.90	4.20	3.70/5.4	5.9	4.40	4.40
S..87	3.30	8.1	6.9/10.4	11.3	8.4	8.4
S..97	6.8	15.0	13.4/18.0	21.8	17.0	17.0

1) The S-series gear unit requires a larger volume when there is a compound gear unit (ex: S67R37).

SF..

Gear unit	Fill quantity in liters					
	M1	M2	M3 ¹⁾	M4	M5	M6
SF37	0.25	0.40	0.50	0.55	0.40	0.40
SF47	0.40	0.90	0.90/1.05	1.05	1.00	1.00
SF57	0.50	1.20	1.00/1.50	1.55	1.40	1.40
SF67	1.00	2.20	2.30/3.00	3.20	2.70	2.70
SF77	1.90	4.10	3.90/5.8	6.5	4.90	4.90
SF87	3.80	8.0	7.1/10.1	12.0	9.1	9.1
SF97	7.4	15.0	13.8/18.8	22.6	18.0	18.0

1) The S-series gear unit requires a larger volume when there is a compound gear unit (ex: SF67R37).

SA.., SH.., SAF.., SHZ.., SAZ.., SHF.., ST..

Gear unit	Fill quantity in liters					
	M1	M2	M3 ¹⁾	M4	M5	M6
S..37	0.25	0.40	0.50	0.50	0.40	0.40
S..47	0.40	0.80	0.70/0.90	1.00	0.80	0.80
S..57	0.50	1.10	1.00/1.50	1.50	1.20	1.20
S..67	1.00	2.00	1.80/2.60	2.90	2.50	2.50
S..77	1.80	3.90	3.60/5.0	5.8	4.50	4.50
S..87	3.80	7.4	6.0/8.7	10.8	8.0	8.0
S..97	7.0	14.0	11.4/16.0	20.5	15.7	15.7

1) The S-series gear unit requires a larger volume when there is a compound gear unit (ex: SA67R37).

SPIROPLAN® (W)
gear units

W.., WF.., WA..B, WH..B

Gear unit	Fill quantity in liters					
	M1	M2	M3	M4	M5	M6
W..10	0.16					
W..20	0.24					
W..30	0.40					
W..37		0.50		0.70		0.50
W..47		0.90		1.40		0.90

WA.., WAF.., WT.., WH.., WHF..

Gear unit	Fill quantity in liters					
	M1	M2	M3	M4	M5	M6
W..10	0.16					
W..20	0.24					
W..30	0.40					
W..37		0.50		0.70		0.50
W..47		0.80		1.25		0.80

7 Design and Operating Data

7.1 Tolerances

Shaft heights The following tolerances apply to the indicated dimensions:

h	≤ 9.84 in	→ -0.02 in
h	> 9.84 in	→ -0.04 in

Foot-mounted gear units: Check the motor diameter because it may project below the mounting feet and require shimming below feet.

Shaft ends

Diameter tolerance:

inch		mm	
∅	> 0.500...1.500	→ +0 / -0.0005	≤ 50 mm → ISO k6
∅	> 1.500...7.500	→ +0 / -0.0010	> 50 mm → ISO m6

Center bores according to DIN 332, shape D [in], shape DR [mm]:

inch		mm	
∅	0.625...0.750	→ 1/4 - 20 x 0.63	= 7...10 mm → M3
∅	1.000	→ 3/8 - 16 x 0.87	> 10...13 mm → M4
∅	1.250...1.375	→ 1/2 - 13 x 1.12	> 13...16 mm → M5
∅	1.625...1.750	→ 5/8 - 11 x 1.38	> 16...21 mm → M6
∅	2.000...2.875	→ 3/4 - 10 x 1.61	> 21...24 mm → M8
∅	3.625...4.750	→ 1 - 8 x 2.13	> 24...30 mm → M10
∅	6.250...7.500	→ 1-1/8 - 7 x 2.13	> 30...38 mm → M12
∅			> 38...50 mm → M16
∅			> 50...85 mm → M20
∅			> 85...130 mm → M24
∅			> 130 mm → M30

Keys: according to DIN 6885.

Hollow shafts

Diameter tolerance:

inch		mm	
→ ANSI H7		→ ISO H7	
∅	0.625	→ +0.0007 / -0	
∅	0.750...1.000	→ +0.0008 / -0	
∅	1.250...1.9375	→ +0.0010 / -0	
∅	2.000...2.9375	→ +0.0012 / -0	
∅	3.250...4.500	→ +0.0014 / -0	

Spline shafts

Dm = Measuring roller diameter
Me = Check size

Flange

Centering shoulder tolerance:

≤ 230 mm (flange sizes A120...A300)	→ ISO j6
> 230 mm (flange sizes A350...A660)	→ ISO h6

Up to two different flange dimensions are available for each size of helical gear unit and Spiroplan® gear unit. The dimension drawings will show the flanges for each size.

7.2 Foot or flange mounting

INFORMATION	
	<p>Alignment is critical when installing gear units with a flange or with feet. Installation recommendations are available online within the Technical Notes section at www.seweurodrive.com.</p> <p>For gear units with a flange, review Technical Note GM-020.</p> <p>For gear units with hollow shaft and feet, review Technical Note GM-019.</p>

7.3 Torque arm mounting

Part Numbers

Gear unit	Size					
	27	37	47	57	67	77
KA, KH, KV, KT	-	643 425 8	643 428 2	643 431 2	643 431 2	643 434 7
SA, SH, ST	-	126 994 1	644 237 4	644 240 4	644 243 9	644 246 3
FA, FH, FV, FT Rubber buffer (2 pieces)	013 348 5	013 348 5	013 348 5	013 348 5	013 348 5	013 349 3

Gear unit	Size				
	87	97	107	127	157
KA, KH, KV, KT	643 437 1	643 440 1	643 443 6	643 294 8	-
SA, SH, ST	644 249 8	644 252 8	-	-	-
FA, FH, FV, FT Rubber buffer (2 pieces)	013 349 3	013 350 7	013 350 7	013 351 5	013 347 7

Gear unit	Size				
	10	20	30	37	47
WA	1 061 021 9	1 68 073 0	1 68 011 0	1 061 129 0	1 061 187 8

As standard, torque arms are not available for gear unit sizes KH167.. and KH187... Consult SEW-EURODRIVE for design proposals if you require torque arms for these gear units.

INFORMATION	
	<p>For proper design and mounting of torque arms, please see Technical Note GM-021 available at www.seweurodrive.com</p>

7.4 TorqLOC® mounting system

Description

The TorqLOC® hollow shaft mounting system is a premier design used for achieving a keyless connection between a customer solid shaft and the hollow shaft of the gear unit. TorqLOC® is the preferred alternative to a hollow shaft with shrink disk, a hollow shaft with key, or a hollow shaft with spline.

TorqLOC® consists of the following components:

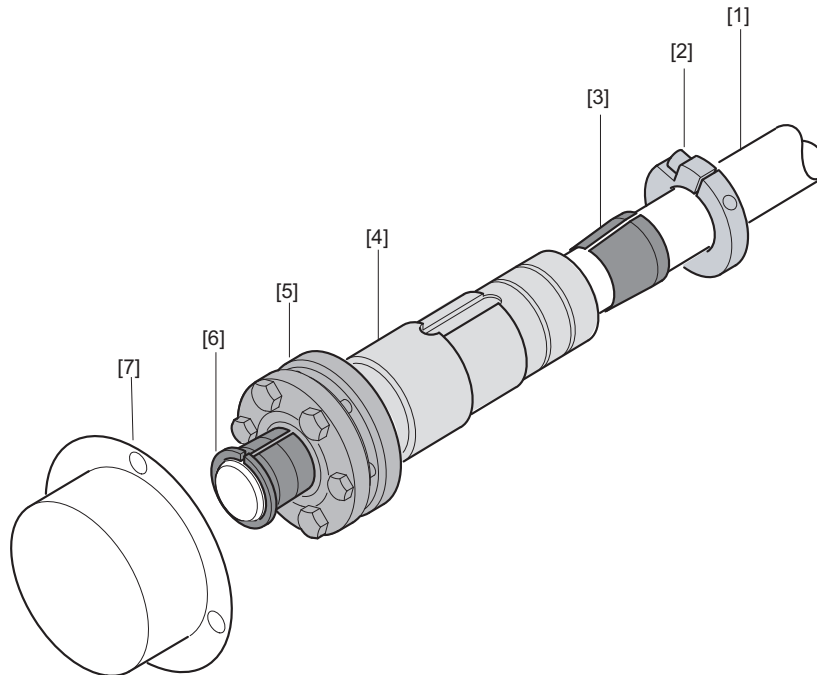

53587AXX

[1]	Customer shaft	[5]	Shrink disk
[2]	Clamping ring	[6]	Tapered bushing (steel or stainless steel)
[3]	Tapered bronze bushing	[7]	Fixed cover
[4]	Hollow shaft inside gear unit		

Advantages

TorqLOC® offers the following advantages:

- Cost savings because the customer shaft can be made from turned shaft stock or cold rolled stock without additional machining.
- Cost savings because there is no keyway to machine.
- A variety of tapered bushings [item 6] are available for each hollow shaft, providing flexibility and various shaft diameter options within the same gear unit.
- Simple installation since there is no key.
- Simple removal even after many hours of operation because there is no contact corrosion. High clamping forces on one end and dissimilar metals on the other end deter corrosion.
- Ease of disassembly - the same screws that are used for tightening during installation can be used for future disassembly.

Technical data TorqLOC® is approved for output torques of 814 lb-in to 159,300 lb-in and is available on the following gear units:

- FT37 .. FT157 ^{the}Snuggler® helical-parallel shaft
- KT37 .. KT157 Helical-bevel, KT39 - KT49 hypoid
- ST37 .. ST97 Helical-worm
- WT37 .. WT47 SPIROPLAN®

Options The following options are available for gear units with TorqLOC®:

- (/T) torque arm option is available on KT.., ST.., WT37, WT47 gear units
- (/G) rubber buffer option is available for the built-in torque arm of FT gear units

Bore sizes The following charts shows the metric and inch bores available with TorqLOC®.

Model	inch				
ST37	0.625	0.6875	0.75	-	-
FT37, KT37, ST47	1.00	1.1875	1.25	-	-
FT47, KT39, KT47, ST57	1.1875	1.25	1.375	1.4375	-
FT57, KT57	1.375	1.4375	1.50	1.625	-
FT67, KT49, KT67, ST67	1.375	1.4375	1.50	1.625	1.688
FT77, KT77, ST77	1.625	1.75	1.9375	2.00	-
FT87, KT87, ST87	1.9375	2.00	2.375	2.4375	-
FT97, KT97, ST97	2.4375	2.75	2.9375	-	-
FT107, KT107	3.250	3.4375	3.625	3.750	-
FT127, KT127	3.4375	3.750	3.937	4.00	4.1875
FT157, KT157	4.4375	4.50	4.9375	5.00	-

Model	mm		
ST37	16	19	20
FT37, KT37, ST47	25	30	-
FT47, KT39, KT47, ST57	30	35	-
KT49	35	40	-
FT57, KT57	35	38	40
FT67, KT67, ST67	35	38	40
FT77, KT77, ST77	50	-	-
FT87, KT87, ST87	51	62	65
FT97, KT97, ST97	62	70	75
FT107, KT107	80	90	95
FT127, KT127	95	100	105
FT157, KT157	110	125	-

INFORMATION



For additional information on TorqLOC®, see Technical Notes **GM-033**, **GM-034**, and **GM-035** available at www.seweurodrive.com.

7.5 Hollow shaft with key

There are two ways to design the customer's solid shaft for use with a gear unit containing a keyed hollow shaft. While both designs are acceptable, the second is more advantageous to the end user because it allows for easier disassembly later, especially if corrosion exists between the two shafts.

Standard Design:

Uses the fastening parts supplied with the gear unit. This design requires a longer customer shaft that extends to the snapping. While this design is very common, it does not permit the use of a removal kit to aid with future removal of the customer's shaft.

Recommended Design:

Uses the optional installation/removal kit. This design requires a shorter customer shaft than the standard design. The shaft does **not** extend to the snapping. The area between the end of the shaft and the snapping contains a gap or a spacer tube, depending if the customer shaft contains a shoulder. During future disassembly, the gap or spacer tube is replaced with a locking nut that allows the user to push out the shaft by turning a wrench. This is especially beneficial in a humid or wet environment where corrosion between the shafts is probable.

7

INFORMATION	
	Always use the supplied NOCO [®] fluid for assembly. The fluid minimizes contact corrosion and facilitates future disassembly.

7.6 Hollow shaft with key - standard design

The standard design uses the parts that are normally supplied with every hollow shaft, as shown in Figure 4. Note the following points concerning the customer's solid shaft:

- See dimension sheets or page 117 for dimension, L8.
- If there is a contact shoulder [A] on the customer shaft, the installation length should be (L8 - 1 mm) or (L8 - 0.04 in).
- If there is no contact shoulder [B] on the customer shaft, the installation length should equal L8.
- Observe the tolerances for dimension, D, in various areas along the shaft.
- Refer to the dimension pages for the diameter and length of retaining screw [2].
- X must be > D. But the key does **not** have to extend the length of shaft.

00 001 00 02US

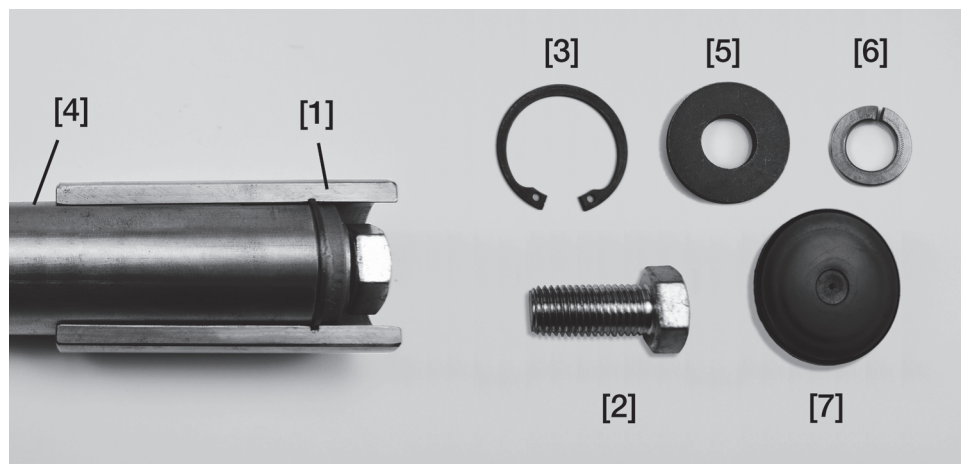
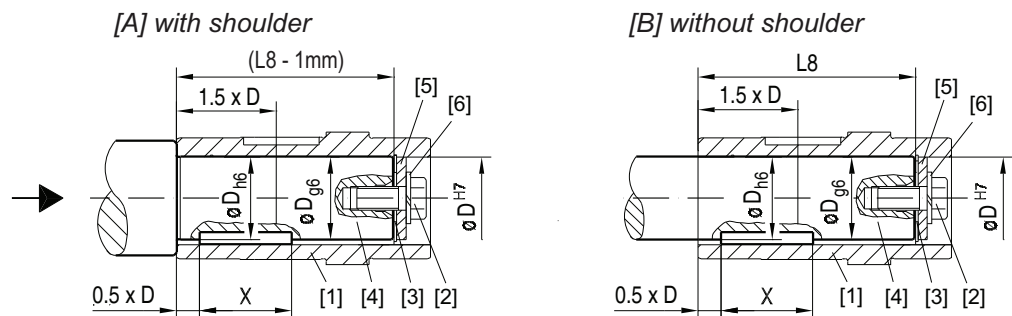

Figure 4: Customer shaft with contact shoulder [A] and without contact shoulder [B]

- | | | | |
|-----|----------------------|-----|------------------------|
| [1] | Hollow shaft | [5] | Flat washer |
| [2] | Retaining screw | [6] | Lock washer |
| [3] | Retaining snapping | [7] | Plastic protection cap |
| [4] | Customer solid shaft | | |

Customer shaft:

The following table lists the dimensions that are needed to design the customer shaft.

Gear Unit	[inch]			[mm]		
	D	STD Screw	L8 ¹⁾	D	STD Screw	L8 ¹⁾
WA..10	0.625	1/4-20 x 5/8	2.72	14	M5 x 16	69
				16		
KA..19	0.750	1/4-20 x 5/8	3.62	20	M6 x 16	92
WA..20	0.750	1/4-20 x 5/8	3.31	18	M6 x 16	84
				20		
FA..27	1.000	3/8-16 x 1	3.47	25	M10 x 25	88
KA..29	1.000	3/8-16 x 1	4.21	25	M10 x 25	107
WA..30, WA..37	0.750	1/4-20 x 5/8	4.13	20	M6 x 16	105
SA..37	0.750	1/4-20 x 5/8	4.09	20	M6 x 16	104
FA..37, KA..37	1.250	7/16-14 x 1	4.13	30	M10 x 25	105
KA..39	1.250	7/16-14 x 1	5.39	30	M10 x 25	137
	1.375	1/2-13 x 1		35	M12 x 30	
WA..47	1.000	3/8-16 x 1	4.80	30	M10 x 25	122
	1.250	7/16-14 x 1				
SA..47	1.250	7/16-14 x 1	4.13	25	M10 x 25	105
				30		
FA..47, KA..47, SA..57	1.250	7/16-14 x 1	5.20	30	M10 x 25	132
	1.375	1/2-13 x 1		35	M12 x 30	
	1.4375	5/8-11 x 1-3/4				
KA..49	1.375	1/2-13 x 1	6.30	35	M12 x 30	160
	1.500	5/8-11 x 1-3/4		40	M16 x 40	
FA..57, KA..57	1.4375	5/8-11 x 1-3/4	5.59	40	M16 x 40	142
	1.500					
FA..67, KA..67	1.4375	5/8-11 x 1-3/4	6.14	40	M16 x 40	156
	1.500					
SA..67	1.250	7/16-14 x 1	5.67	40	M16 x 40	144
	1.500	5/8-11 x 1-3/4		45		
FA..77, KA..77	1.9375	5/8-11 x 1-3/4	7.21	50	M16 x 45	183
	2.000					
SA..77	2.000	5/8-11 x 1-3/4	7.21	50	M16 x 45	183
				7.09	60	M20 x 50
FA..87, KA..87	2.375	3/4-10 x 2	8.27	60	M20 x 50	210
	2.4375					
SA..87	2.375	3/4-10 x 2	8.66	60	M20 x 50	220
				70		
FA..97, KA..97	2.750	3/4-10 x 2	10.63	70	M20 x 50	270
	2.9375					
SA..97	2.750	3/4-10 x 2	10.24	70	M20 x 50	260
				10.04	90	M24 x 60
FA..107, KA..107	3.250	3/4-10 x 2	12.32	90	M24 x 60	313
	3.4375			80	M20 x 50	
	3.625					
FA..127, KA..127	4.000	1-8 x 2-1/4	14.69	100	M24 x 60	373
FA..157, KA..157	4.500		18.11			120

1) If customer shaft does not contain a shoulder, then the installation length of customer shaft = L8.
If customer shaft contains a shoulder, the installation length = (L8 - 1mm) or (L8 - 0.04")

7 Design and Operating Data

Hollow shaft with key - standard design

Installation procedure:

1. Apply and thoroughly spread NOCO fluid (normally supplied with unit).

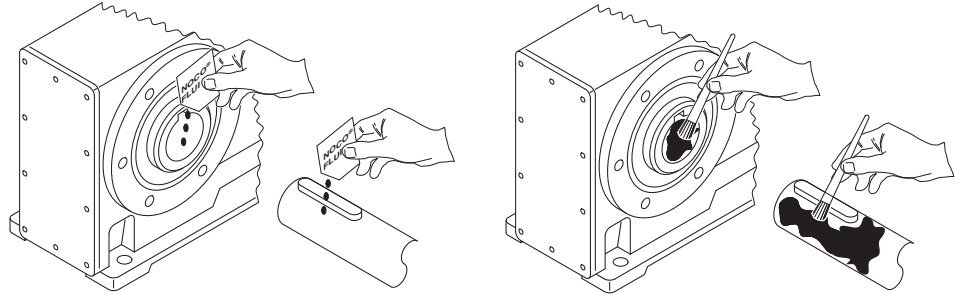

211516171

2. Install the shaft and secure it axially with the hardware supplied.

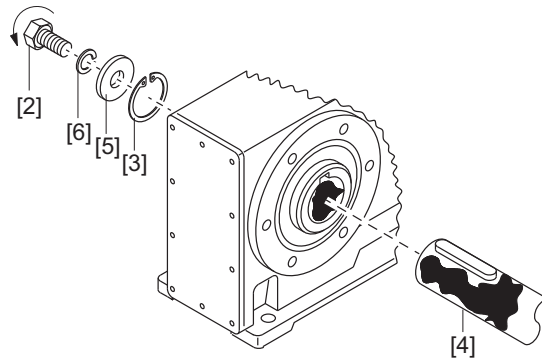

211518347US

- [2] Shorter retaining screw (normally supplied)
- [3] Retaining snapping
- [4] Customer shaft
- [5] Flat washer
- [6] Lock washer

3. Tighten the retaining screw to the appropriate torque shown in table below.

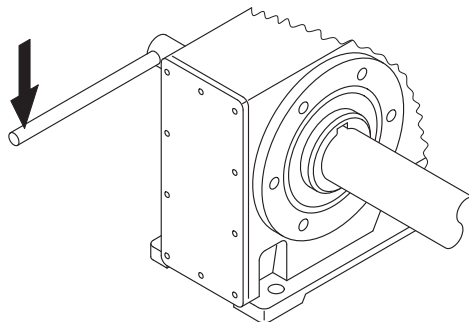

Screw		Tightening torque Nm / lb-in
Metric	SAE	
M5		5 / 44
M6	1/4-20	8 / 71
M10	7/16-14	20 / 177
M12	1/2-13	
M16	5/8-11	40 / 355
M20	3/4-10	80 / 710
M24	1-8	200 / 1770

211524875

7.7 Hollow shaft with key - recommended design

The recommended design uses the standard hardware along with a removal kit, as shown dotted in Figure 5. Since the normal retaining screw is too short, the removal kit includes a longer screw [2]. The customer may make his own kit or purchase it from SEW-EURODRIVE. Kit part numbers and dimensions are shown on page 121.

Please observe the following:

- Items 3, 5, 6, and 7 are normally supplied with the hollowshaft, so they are not included in the kit.
- The longer retaining screw [2] can be used for both assembly and removal.
- The installation length of the customer shaft must be LK2, regardless if the shaft has a contact shoulder or not. See page 120 for LK2 dimension. Observe that the customer shaft does not extend to the snapping.
- The spacer tube [8] is not needed if the customer shaft has a shoulder.
- X must be > D. But the key does **not** have to extend the length of shaft.

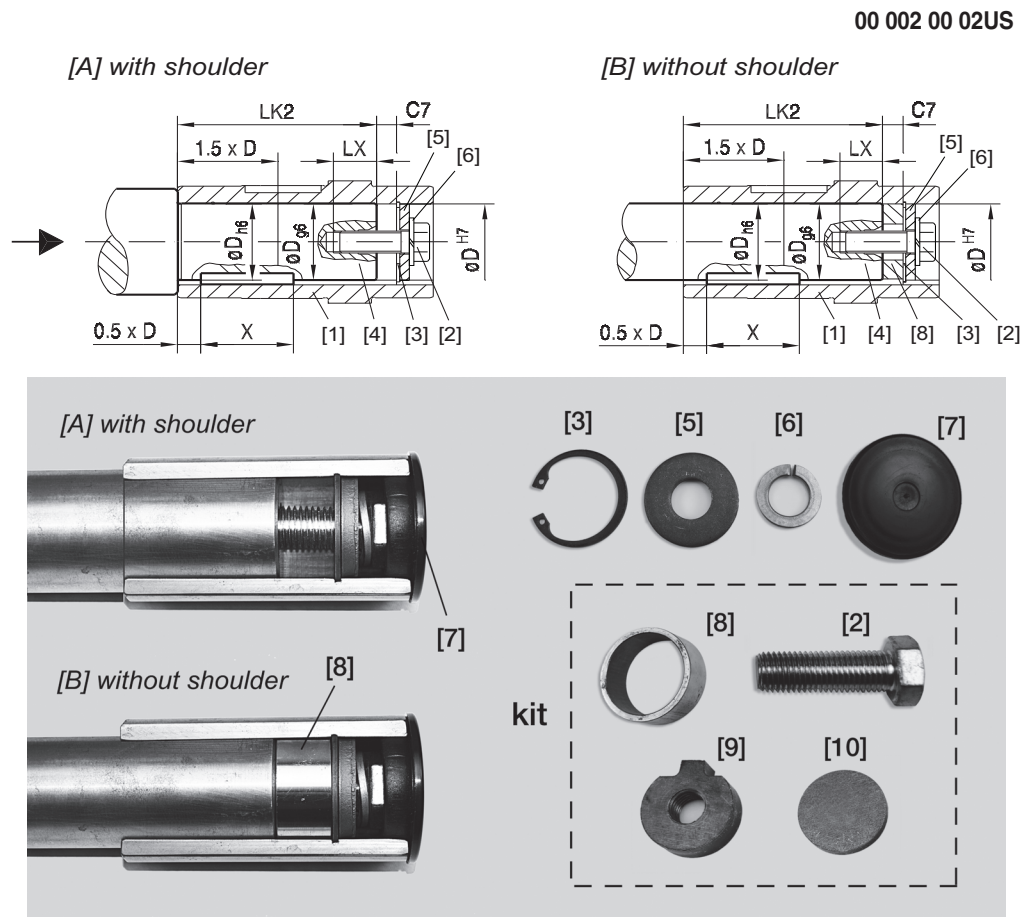

Figure 5: Customer shaft with contact shoulder (A) and without contact shoulder (B)

[1]	Hollow shaft	[6]	Lock washer
[2]	Retaining screw (for assembly & removal)	[7]	Protection cap
[3]	Snapping	[8]	Spacer tube (not needed w/shoulder)
[4]	Customer shaft	[9]	Locking nut (for removal only)
[5]	Flat washer	[10]	Forcing washer (for removal only)

7 Design and Operating Data

Hollow shaft with key - recommended design

Customer shaft:

The following table lists the recommended dimensions for the shaft length and depth of tap to enable the use of a shaft removal kit.

Gear Unit	D		LK2 [mm]	LX ⁺² [mm]	C7 [mm]	
	[inch]	[mm]				
WA..10	0.625	14	58	12.5	11	
		16				
KA..19	0.750	20	80	16	12	
WA..20	0.750	18	72	16	12	
		20				
FA..27	1.000	25	72	22	16	
KA..29	1.000	25	91	22	16	
WA..30, WA..37	0.750	20	93	16	12	
SA..37	0.750	20	92	16	12	
FA..37, KA..37	1.250	30	89	22	16	
KA..39	1.250	30	121	22	16	
	1.375	35				
WA..47	1.000	30	106	22	16	
	1.250					
SA..47	1.250	25	89	22	16	
		30				
FA..47, KA..47, SA..57	1.250	30	116	22	16	
		1.375				
		1.4375				
KA..49	1.375	35	142	28	18	
	1.500	40				
FA..57, KA..57	1.4375	40	124	26	18	
	1.500					
FA..67, KA..67	1.4375	40	138	36	18	
	1.500					
SA..67	1.250	40	126	36	18	
	1.500	45				
FA..77, KA..77	1.9375	50	165	36	18	
	2.000					
SA..77	2.000	50	165	36	18	
		60	158	42	22	
FA..87, KA..87	2.375	60	188	42	22	
	2.4375					
SA..87	2.375	60	198	42	22	
		70				
FA..97, KA..97	2.750	70	248	42	22	
	2.9375					
SA..97	2.750	70	238	42	22	
		90	229	52	26	
FA..107, KA..107	3.250		289	52	24	
		3.4375	80	287	52	26
		3.625	90			
FA..127, KA..127	4.000	100	347	62	26	
FA..157, KA..157	4.500	120	434	62	26	

Kit dimensions and part numbers:

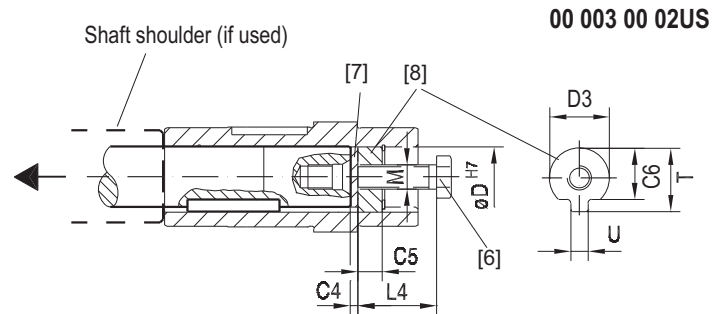

00 003 00 02US

- [6] Longer retaining screw
- [7] Forcing washer
- [8] Locking nut

Metric Bores:

D [mm]	M	C4 [mm]	C5 [mm]	C6 [mm]	U ^{-0.5} [mm]	T ^{-0.5} [mm]	D3 ^{-0.5} [mm]	L4 [mm]	Kit Part Number
16	M5	5	5	12	4.5	18	15.7	50	643 712 5
18	M6		6	13.5	5.5	20.5	17.7	25	643 682 X
20				15.5	5.5	22.5	19.7		643 683 8
25	M10		10	20	7.5	28	24.7	35	643 684 6
30				25	7.5	33	29.7		643 685 4
35	M12		12	29	9.5	38	34.7	45	643 686 2
40	M16			34	11.5	41.9	39.7	50	643 687 0
45				38.5	13.5	48.5	44.7		643 688 9
50				43.5	13.5	53.5	49.7		643 689 7
60	M20		16	56	17.5	64	59.7	60	643 690 0
70				65.5	19.5	74.5	69.7	643 691 9	
90	M24		20	80	24.5	95	89.7	70	643 692 7
100				89	27.5	106	99.7	643 693 5	
120				107	31	127	119.7	643 694 3	

Inch Bores:

D [inch]	M	C4 [mm]	C5 [mm]	C6 [inch]	U ^{-0.02} [inch]	T ^{-0.02} [inch]	D3 ^{-0.02} [inch]	L4 [inch]	Kit Part Number
0.625	1/4-20	5	5	0.500	0.168	0.701	0.6130	2.0	250 546 00
0.750	1/4-20		6	0.625		0.835	0.738	1.0	250 546 19
1.000	7/16-14		10	0.863	0.230	1.110	0.988	1.5	250 546 27
1.250	7/16-14			1.113		1.362	1.238		250 546 35
1.375	1/2-13		12	1.142	0.293	1.509	1.363	1.75	250 546 43
1.4375	5/8-11			1.205		0.356	1.602	1.4255	2.0
1.500	5/8-11			1.267	1.657		1.4880	250 546 78	
1.9375	5/8-11			1.682	0.480	2.148	1.9255	250 546 86	
2.00	5/8-11		1.744	2.224		1.9880	250 546 94		
2.375	3/4-10		16	2.119	0.606	2.650	2.3630	2.5	250 247 08
2.4375	3/4-10			2.182		2.605	2.4255	250 547 16	
2.750	3/4-10			2.488	3.031	2.7380	250 547 24		
2.9375	3/4-10		18	2.676	0.730	3.128	2.9255	3.0	250 547 32
3.250	3/4-10			2.938		3.587	3.2380		250 547 40
3.4375	3/4-10		20	3.126	0.856	3.685	3.4255		250 547 59
3.6250	1-8			3.263		3.873	3.6130		250 547 67
4.000	1-8	3.588		0.980	4.441	3.9880	250 547 75		
4.500	1-8	4.088	4.933		4.4880	250 547 83			

Installation procedure:

1. Apply and thoroughly spread NOCO fluid (normally supplied with unit).

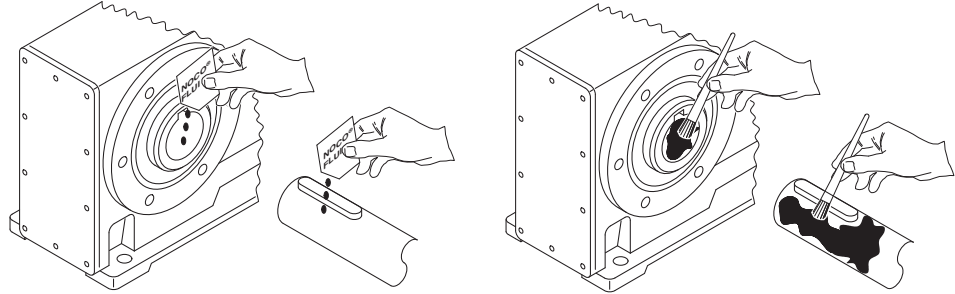

211516171

2. Install the shaft and secure it axially with the hardware supplied.

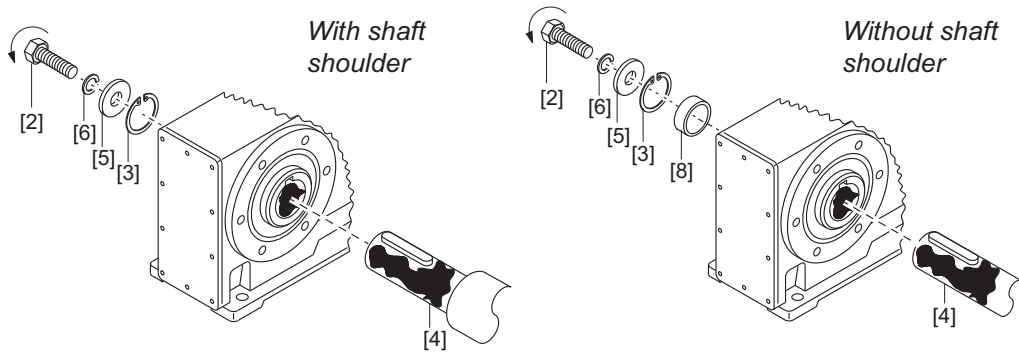

211520523US

- [2] Longer retaining screw
- [3] Snapping
- [4] Customer shaft
- [5] Flat washer
- [6] Lock washer
- [8] Spacer tube

3. Tighten the retaining screw to the appropriate torque shown in table below.

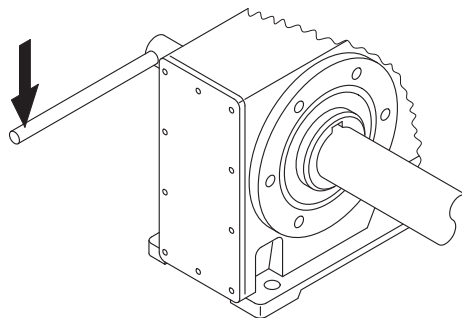

Screw		Tightening torque Nm / lb-in
Metric	SAE	
M5		5 / 44
M6	1/4-20	8 / 71
M10	7/16-14	20 / 177
M12	1/2-13	
M16	5/8-11	40 / 355
M20	3/4-10	80 / 710
M24	1-8	200 / 1770

211524875

Removal procedure:

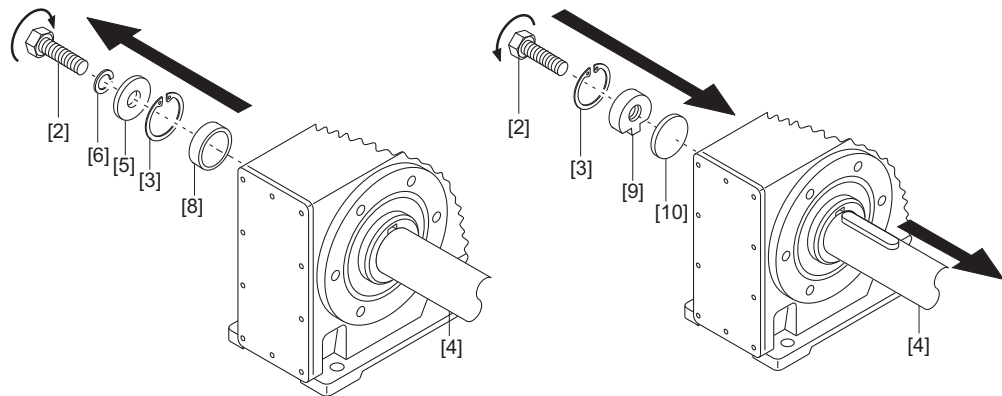

211527051US

- | | |
|----------------------------|---------------------|
| [2] Longer retaining screw | [6] Lock washer |
| [3] Snapping | [8] Spacer tube |
| [4] Customer shaft | [9] Locking nut |
| [5] Flat washer | [10] Forcing washer |

1. Loosen the retaining screw [2].
2. Remove parts [3], [5], and [6]. Also, remove the spacer tube, [8], if applicable.
3. Using the parts [9] and [10] from the removal kit, insert the forcing washer and the locking nut until they rest against the customer shaft [4].
4. Re-install the snapping [3].
5. Thread the retaining screw [2] into the locking nut, as shown in cutaway below.
6. Turn the screw with wrench to force the shaft out of the gear unit.

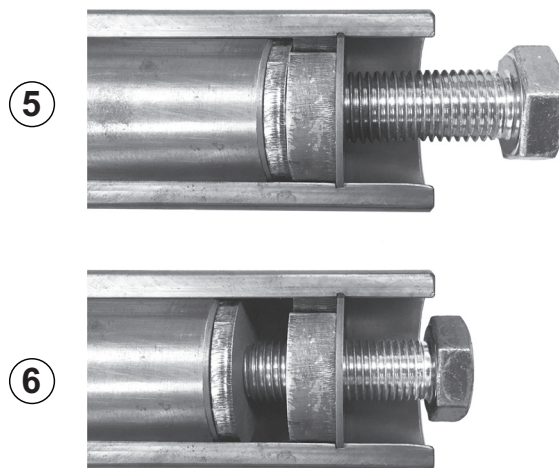

7.8 Bolts and eyebolts

Use bolts of quality 8.8 to fasten gear units.

Exception

Use bolts of quality 10.9 to fasten the following flange-mounted and foot/flange-mounted gear units in order to transmit the rated torques:

- RF37, R37F with flange Ø 120 mm
- RF47, R47F with flange Ø 140 mm
- RF57, R57F with flange Ø 160 mm
- RZ37 - RZ87

Eyebolts, lifting eyes

R07..R27 helical gear units, motors up to DR..100 and the Spiroplan® gearmotors W..10 to W..30 are delivered without additional hardware for ease of handling. All other gear units and motors are equipped with either cast-on suspension eye lugs, screw-on suspension eye lugs or screw-on lifting eyebolts, as noted below.

Gear Unit	Screw-on		Cast-on eyebolts
	lifting eyebolts	eyebolts	
R..37 - R..57		•	
R..67 - R..107	•		
RX57 - RX67		•	
RX77 - RX107	•		
F..27 - F..157			•
K..37 - K..157			•
K..167 - K..187	•		
S..37 - S..47		•	
S..57 - S..97			•
W37 - W47		•	

7.9 Reduced backlash

Helical, parallel shaft helical and helical-bevel gear units with reduced backlash are available from gear size 37. The circumferential backlash of these units is considerably less than that of the standard version to ensure higher precision when positioning. The circumferential backlash is specified in angular minutes ['] in the technical data. The circumferential backlash for the output shaft is specified with no load (max. 1% of the rated output torque) while the gear unit input end is blocked.

The reduced backlash variant is available for the following gear units:

- Helical gear units (R), sizes 37 to 167
- Parallel-shaft gear units (F), sizes 37 to 157
- Helical-bevel gear units (K), sizes 37 to 187

Compound gear units (ex: F67R37..) are not available in the reduced backlash option.

The dimensions for reduced backlash design are the same as the dimensions of the standard design, except for parallel-shaft sizes FH.87 and FH.97. The following figure shows the dimensions (mm) of the FH.87 and FH.97 with reduced backlash.

42 020 00 09

**FH../R
FH..B/R**

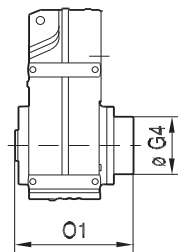

FHF../R

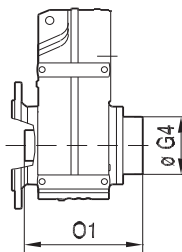

FHZ../R

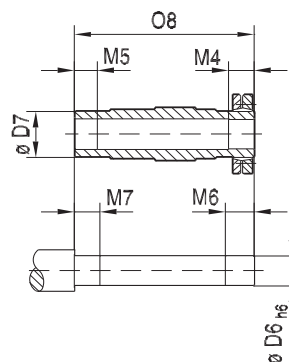
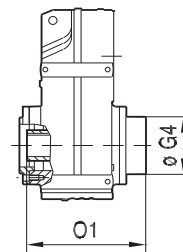

Type	D6	D7	G4	M4	M5	M6	M7	O1	O8
FH.87/R	∅ 65 _{h6}	∅ 85	∅ 163	41	40	46	45	312.5	299.5
FH.97/R	∅ 75 _{h6}	∅ 95	∅ 184	55	50	60	55	382.5	367

7.10 Flange detail dimensions - RF.. and R..F

04355AXX

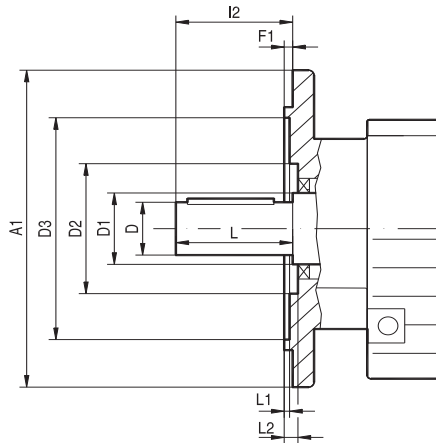

Check dimensions L1 and L2 for selection and installation of output elements.

Type	Dimensions in mm											
	A1	D ¹⁾	D1	D2		D3	F1	I2	L	L1		L2
				RF	R..F					RF	R..F	
RF07, R07F	120	20	22	38	38	72	3	40	40	2	2	6
	140 ²⁾				-	85	3			2	-	6
	160 ²⁾				-	100	3.5			2.5	-	6.5
RF17, R17F	120	20	25	46	46	65	3	40	40	1	1	5
	140				-	78	3			1	-	5
	160 ²⁾				-	95	3.5			1	-	6
RF27, R27F	120	25	30	54	54	66	3	50	50	1	1	6
	140				-	79	3			3	-	7
	160				-	92	3.5			3	-	7
RF37, R37F	120	25	35	60	63	70	3	50	50	5	4	7
	160				-	96	3.5			1	-	7.5
	200 ²⁾				-	119	3.5			1	-	7.5
RF47, R47F	140	30	35	72	64	82	3	60	60	4	1	6
	160				-	96	3.5			0.5	-	6.5
	200				-	116	3.5			0.5	-	6.5
RF57, R57F	160	35	40	76	75	96	3.5	70	70	4	2.5	5
	200				-	116	3.5			0	-	5
	250 ²⁾				-	160	4			0.5	-	5.5
RF67, R67F	200	35	50	90	90	118	3.5	70	70	2	4	7
	250				-	160	4			1	-	7.5
RF77, R77F	250	40	52	112	100	160	4	80	80	0.5	2.5	7
	300 ²⁾				-	210	4			0.5	-	7
RF87, R87F	300	50	62	123	122	210	4	100	100	0	1.5	8
	350				-	226	5			1	-	9
RF97	350	60	72	136		236	5	120	120	0		9
	450					320						
RF107	350	70	82	157		232	5	140	140	0		11
				450		316						
RF137	450	90	108	180		316	5	170	170	0		10
					550							
RF147	450	110	125	210		316	5	210	210	0		10
					550							
RF167	550	120	145	290		416	5	210	210	1		10
					660					517	6	2

1) For dimension, D, for inch shafts see page 272.

2) The flange contour protrudes below the base surface.

7.11 Flange detail dimensions - FF., KF., SF. and WF..

64353AXX

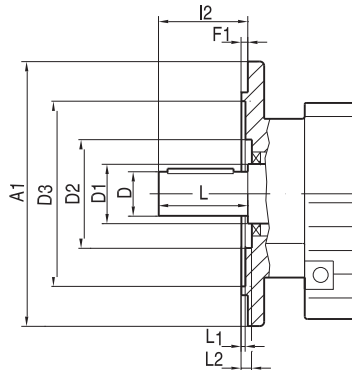

Check dimensions L1 and L2 for selection and installation of output elements.

7

Type	Dimensions in mm									
	A1	D ¹⁾	D1	D2	D3	F1	I2	L	L1	L2
FF27	160	25	40	66	96	3.5	50	50	3	18.5
FF37	160	25	30	70	94	3.5	50	50	2	6
FF47	200	30	40	72	115	3.5	60	60	3.5	7.5
FF57	250	35	40	84	155	4	70	70	4	9
FF67	250	40	50	84	155	4	80	80	4	9
FF77	300	50	55	82	205	4	100	100	5	9
FF87	350	60	65	115	220	5	120	120	5	9
FF97	450	70	75	112	320	5	140	140	8	10
FF107	450	90	100	159	318	5	170	170	16	9
FF127	550	110	118	-	420	5	210	210	10	-
FF157	660	120	135	190	520	6	210	210	8	14
KF37	160	25	30	70	94	3.5	50	50	2	6
KF47	200	30	40	72	115	3.5	60	60	3.5	7.5
KF57	250	35	40	84	155	4	70	70	4	9
KF67	250	40	50	84	155	4	80	80	4	9
KF77	300	50	55	82	205	4	100	100	5	9
KF87	350	60	65	115	220	5	120	120	5	9
KF97	450	70	75	112	320	5	140	140	8	10
KF107	450	90	100	159	318	5	170	170	16	9
KF127	550	110	118	-	420	5	210	210	10	-
KF157	660	120	135	190	520	6	210	210	8	14
SF37	120	20	25	-	68	3	40	40	6	-
	160	20	25	-	96	3.5	40	40	5.5	-
SF47	160	25	30	70	94	3.5	50	50	2	6
SF57	200	30	40	72	115	3.5	60	60	3.5	7.5
SF67	200	35	45	-	115	3.5	70	70	8.5	-
SF77	250	45	55	108	160	4	90	90	8	9
SF87	350	60	65	130	220	5	120	120	6	10
SF97	450	70	75	150	320	5	140	140	8.5	10
WF10	80	16	25	-	39	2.5	40	40	30	-
	120	16	25	39	74	3	40	40	5	30
WF20	110	20	30	44	53	-4	40	40	27	35
	120	20	30	-	45	2.5	40	40	37.5	-
WF30	120	20	30	48	63	2.5	40	40	18	27
	160	20	30	48	63	2.5	40	40	33	42
WF37	120	20	30	-	70	2.5	40	40	-	10.5
	160	20	30	-	70	2.5	40	40	-	25.5
WF47	160	30	35	-	92	3.5	10	60	6	-

1) For dimension, D, for inch shafts see page 407 (FF), 571 (KF), 680 (SF), or 706 (WF).

7 Design and Operating Data

Flange detail dimensions - FAF., KAF., SAF. and WAF..

7.12 Flange detail dimensions - FAF., KAF., SAF. and WAF..

64355AXX

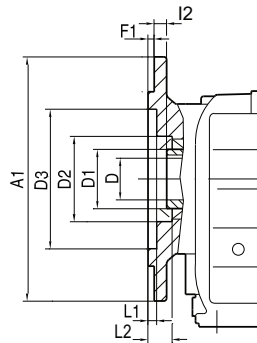

Check dimensions L1 and L2 for selection and installation of output elements.

Type	Dimensions in mm								
	A1	D ¹⁾	D1	D2	D3	F1	I2	L1	L2
FAF27	160	25	40	66	96	3.5	20	3	18.5
FAF37	160	30	45	62	94	3.5	24	2	30
FAF47	200	35	50	70	115	3.5	25	3.5	31.5
FAF57	250	40	55	76	155	4	23.5	4	31
FAF67	250	40	55	76	155	4	23	4	31
FAF77	300	50	70	95	205	4	37	5	45
FAF87	350	60	85	120	220	5	30	5	39
FAF97	450	70	95	135	320	5	41.5	5.5	51
FAF107	450	90	118	224	320	5	41	16	52
FAF127	550	100	135	185	420	5	51	6	63
FAF157	660	120	155	200	520	6	60	10	74
KAF37	160	30	45	62	94	3.5	24	2	30
KAF47	200	35	50	70	115	3.5	25	3.5	8.5
KAF57	250	40	55	76	155	4	23.5	4	31
KAF67	250	40	55	76	155	4	23	4	31
KAF77	300	50	70	95	205	4	37	5	45
KAF87	350	60	85	120	220	5	30	5	39
KAF97	450	70	95	135	320	5	41.5	5.5	51
KAF107	450	90	118	224	320	5	41	16	52
KAF127	550	100	135	185	420	5	51	6	63
KAF157	660	120	155	200	520	6	60	10	74
SAF37	120	20	35	-	68	3	15	6	-
	160	20	35	-	96	3.5	15	5.5	-
SAF47	160	30 / 25	45	62	94	3.5	24	2	30
SAF57	200	35 / 30	50	70	115	3.5	25	3.5	31.5
SAF67	200	45 / 40	65	91	115	3.5	42.5	4	48.5
SAF77	250	60 / 50	80	112	164	4	45.5	5	53.5
SAF87	350	70 / 60	95	131	220	5	52.5	6	62.5
SAF97	450	90 / 70	120	160	320	5	60	6.5	69
WAF10	80	16	25	-	39	2.5	23	30	-
	120	16	25	39	74	3	23	5	30
WAF20	110	18 / 20	30	44	53	-4	30	27	35
	120	18 / 20	30	-	45	2.5	30	37.5	-
WAF30	120	20	30	48	63	2.5	19.5	18	27
	160	20	30	48	63	2.5	34.5	33	42
WAF37	120	20 / 25	35	54	70	2.5	19.5	10.5	27
	160	20 / 25	35	54	70	2.5	34.5	25.5	42
WAF47	160	25 / 30	45	72	92	3.5	10	6	45

1) For dimension, D, for inch shafts see page 409 (FAF), 573 (KAF), 682 (SAF), or 708 (WAF).

7.13 Hollow shaft covers

Gear units with shrink discs (ex: FH, SH, KH) sizes 37 - 97 are supplied with a fixed cover, as shown below. These covers are available as an option for gear units with a hollow shaft and key (ex: FA, KA, SA).

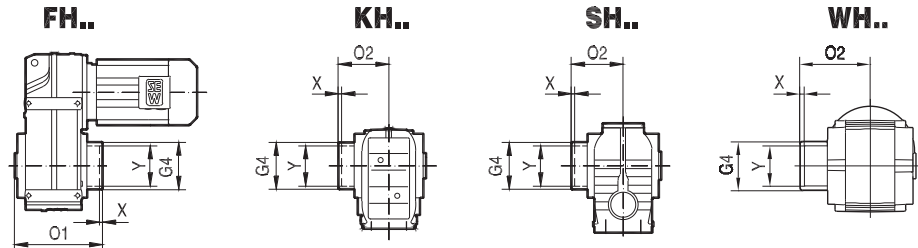
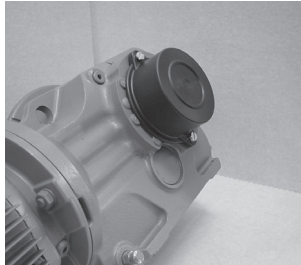

03190AUS / 62664AXX

7

Part numbers and dimensions

FH..	FH..37	FH..47	FH..57	FH..67	FH..77	FH..87	FH..97
Part number	643 513 0	643 514 9	643 515 7	643 515 7	643 516 5	643 517 3	643 518 1
G4	78	88	100	100	121	164	185
O1	157	188.5	207.5	221.5	255	295	363.5
X	2	4.5	7.5	6	6	4	6.5
Y	75	83	83	93	114	159	174

KH.. ¹⁾	KH..37	KH..47	KH..57	KH..67	KH..77	KH..87	KH..97
Part number	643 513 0	643 514 9	643 515 7	643 515 7	643 516 5	643 517 3	643 518 1
G4 [mm]	78	88	100	100	121	164	185
O2 [mm]	95	111.5	122.5	129	147	172	210.5
X [mm]	0	1.5	5.5	3	1	2	4.5
Y [mm]	75	83	83	93	114	159	174

1) Not possible on foot-mounted helical-bevel gear units with hollow shaft and shrink disk (KH..B). There are no mouting holes.

SH..	SH..37	SH..47	SH..57	SH..67	SH..77	SH..87	SH..97
Part number	643 512 2	643 513 0	643 514 9	643 515 7	643 516 5	643 517 3	643 518 1
G4 [mm]	59	78	88	100	121	164	185
O2 [mm]	88	95	111.5	123	147	176	204.5
X [mm]	1	0	1.5	3	1	0	0.5
Y [mm]	53	75	83	93	114	159	174

WH..SPIROPLAN®	WH..37	WH..47
Part number	1 061 136 3	1 061 194 0
G4 [mm]	68	80.5
O2 [mm]	95.5	109.5
X [mm]	11	12.5
Y [mm]	50	72

7.14 Chamfers on hollow shafts

The following illustration shows the chamfers on gear units with hollow shaft:

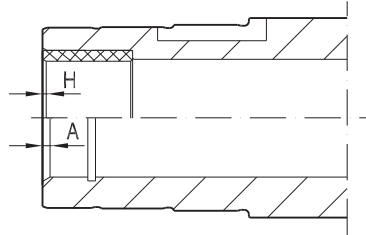

59845AXX

Gear unit	Type	
	with hollow shaft (A)	with hollow shaft and shrink disk (H)
W..10 - W..30	2 × 30°	-
F..27	2 × 30°	0.5 × 45°
F../K../S../W..37	2 × 30°	0.5 × 45°
F../K../S../W..47	2 × 30°	0.5 × 45°
S..57	2 × 30°	0.5 × 45°
F../K../S..67	2 × 30°	3 × 2°
F../K../S..77	2 × 30°	3 × 2°
F../K../S..87	3 × 30°	3 × 2°
F../K../S..97	3 × 30°	3 × 2°
F../K..107	3 × 30°	3 × 2°
F../K..127	5 × 30°	1.5 × 30°
F../K..157	5 × 30°	1.5 × 30°
KH167	-	1.5 × 30°
KH187	-	1.5 × 30°

Special motor/gear unit combinations

Please note for parallel shaft helical gearmotors with hollow shaft (FA..B, FV..B, FH..B, FAF, FVF, FHF, FA, FV, FH, FT, FAZ, FVZ, FHZ):

- If the customer shaft is pushed all the way through the hollow shaft to extend beneath the motor, there may be interference when a "small gear unit" is used in combination with a "large motor."
- Check the motor dimension AC to decide whether there will be interference when the customer shaft is pushed through.

7.15 General dimension notes

Breather valves The gear unit dimension drawings are shown with screw plugs. As standard, the corresponding screw plug is replaced with a breather valve depending on the mounting position M1...M6 specified on the order. Thus, dimensions might be slightly different.

Shrink disk connection For hollow shaft gear unit with shrink disk connection: If required, please request a detailed data sheet on shrink disks, data sheet no. 33 753 ..95.

Splined hollow shaft FV.. hollow shaft gear units in sizes 27 ... 107 and KV.. in sizes 37 ... 107 are delivered with a splined hollow shaft according to DIN 5480 (tooth space tolerance 9H).

Rubber buffer for FA/FH/FV/FT The value, mL, indicates the preloaded rubber buffer. The characteristic curve for the spring value of the rubber buffers is available at SEW-EURODRIVE upon request.

AD../P input shaft with motor platform The following cases can arise with gear units with input shaft assemblies and motor mounting platforms:

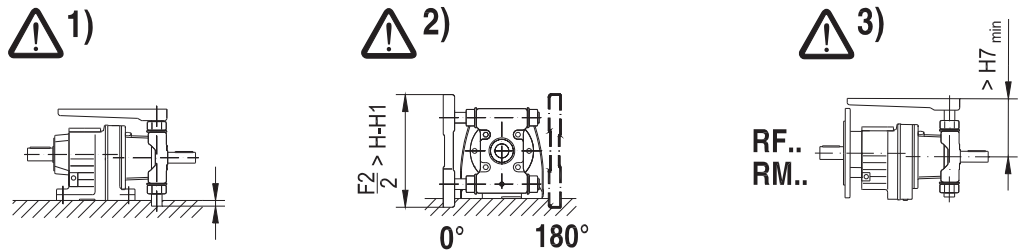

1. Depending on the setting, the column may protrude past the foot mounting surface
2. Motor mounting platform may protrude past the foot mounting surface
3. Motor mounting platform may collide with the gear unit flange, depending on the setting

The corresponding cases are indicated in the dimension tables in the following column:

E2	F2	G2	H6	H7 min	H7 max	H11 min	H11 max	K2	Q4	D1	L1	L13	L14	T1	U1	 →118
----	----	----	----	--------	--------	---------	---------	----	----	----	----	-----	-----	----	----	----------

53696AXX

7.16 Explanation of dimensions

AR and AM..

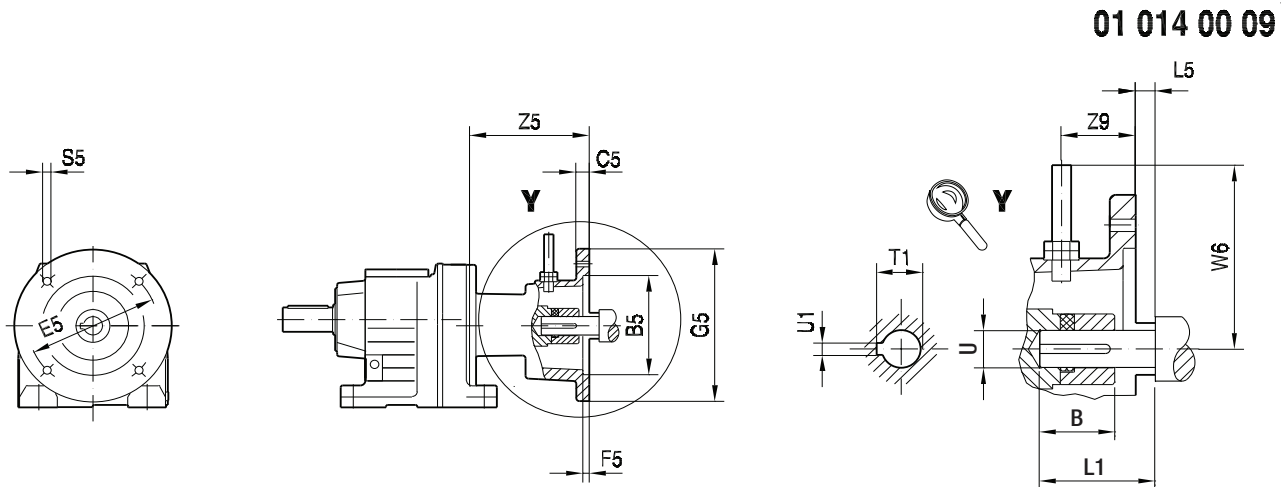

65973axxUS

B	Shaft end to coupling end (indicates where to place coupling onto motor when assembling motor to adapter)	L5	Shaft collar length to flange surface
B5	Center bore diameter	S5	Threaded hole diameter
C5	Flange thickness	T1	Height to top of keyway
E5	Hole circle diameter	U	Coupling bore diameter
F5	Centering depth	U1	Keyway width
G5	Adapter flange diameter	W6	Encoder height
L1	Length from shaft collar to shaft end	Z5	Adapter length
		Z9	Encoder position

AD../ZR

01 178 00 09

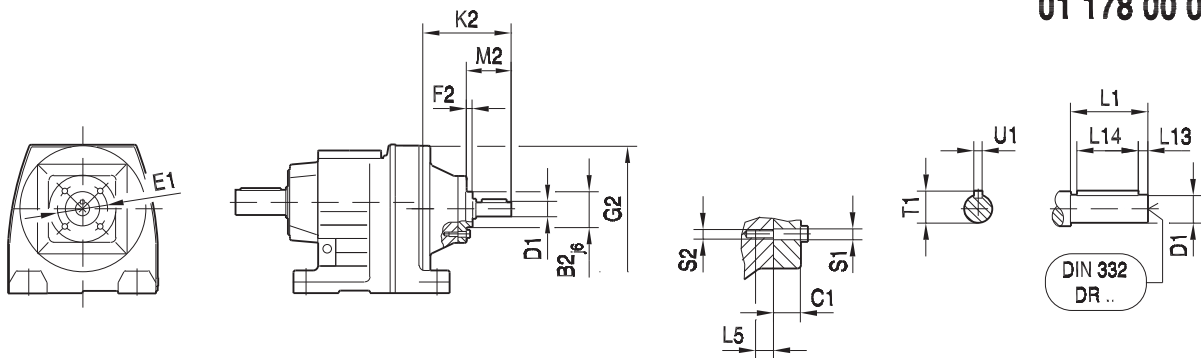

67786axx

B2	Center bore diameter	L13	Position of key
C1	Flange thickness	L14	Key length
D1	Shaft diameter	L5	Thread depth
E1	Hole circle diameter	M2	Contact surface position
F2	Center bore height	S1	Through bore
G2	Flange diameter on input side of gear unit	S2	Thread diameter
K2	Input shaft assembly length	T1	Height to top of key
L1	Length from shaft collar to shaft end	U1	Key width

7 Design and Operating Data

Explanation of dimensions

AD../P

01 179 00 09

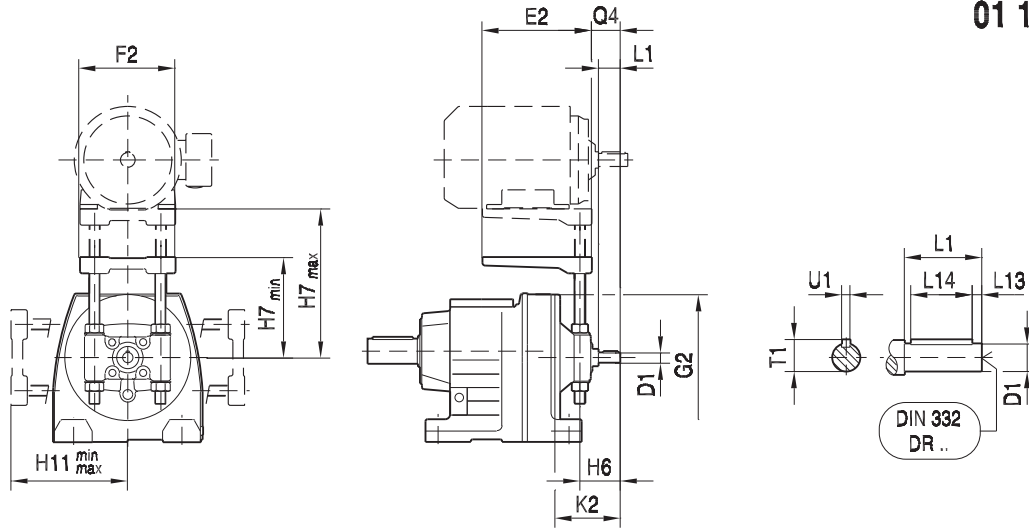

67784axx

D1	Shaft diameter	K2	Input shaft assembly length
E2	Length of motor mounting platform	L1	Length of shaft end
F2	Width of motor mounting platform	L13	Position of key
G2	Flange diameter on input side of gear unit	L14	Key length
H11	Adjusting height (0°, 180°)	Q4	Distance of shaft end and base plate
H6	Distance of shaft end to middle of column	T1	Key height in shaft
H7	Adjusting height	U1	Key width

7.17 Overview of selection tables

AM example

R77, n _e = 1700 rpm						7260 lb-in					
Stages	i [ratio]	n _a [rpm]	T _{a max} [lb-in]	F _{Ra} [lb]	φ (/R) [']	AM					
						56	143	145	182	184	213/215
R77  2	5.31	320	4510	710	8						
	5.99	284	4770	700	8						
	6.79	250	5130	660	8						
	7.74	220	5390	675	8						
	8.59	198	5570	705	7						
	9.64	176	5570	1190	7						
	10.88	156	5830	1220	6						

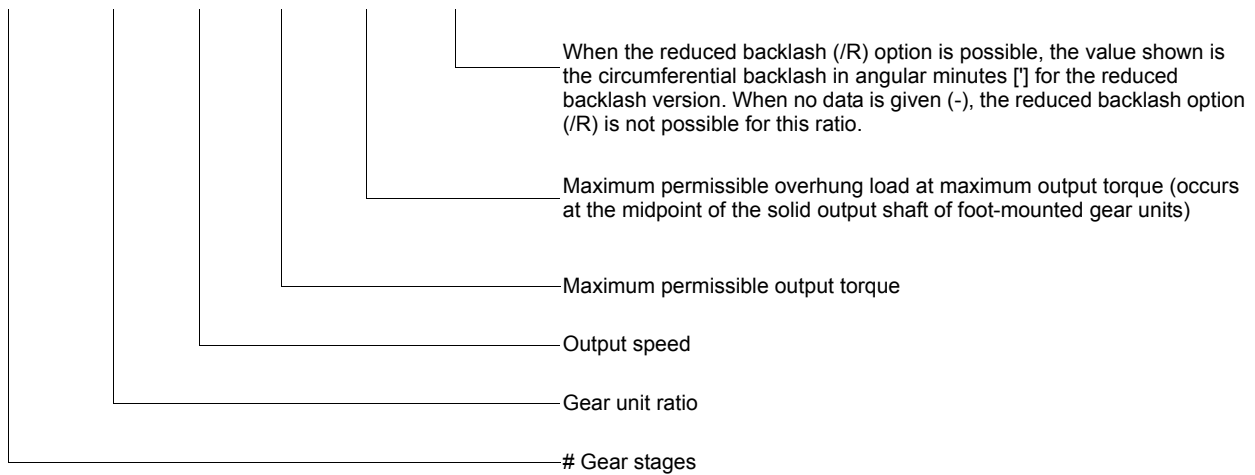

Key

	Combination is possible .
	Combination is not possible .

Weights

The weights of the gear units are shown at the bottom of the selection table for each gear unit, as shown below.



Weight [lbs]		Stages	AM							
			143	145	182	184	213/215	254/256	284/286	
R87	NEMA	2	135	135	145	145	160	190	195	
		3	140	140	150	150	160	190	195	
	IEC		80	90	100	112	132S/M	160	180	
		2	135	135	145	145	165	200	200	
		3	140	140	150	150	165	200	205	

RF87: + 16 lbs / RM87: +81 lbs

7 Design and Operating Data

Overview of selection tables

AD example

R107 AD.. , $n_e = 1700$ rpm										38060 lb-in	
i [ratio]	n_a [rpm]	$T_{a\ max}$ [lb-in]	P_e [HP]	$F_{Ra}^{1)}$ [lb]	F_{Re} [lb]	Stages		ϕ (/R) [']			
						Lg	Sm			[10]	[11]
	[1]	[2]	[3]	[4]	[5]	[6]	[7]	[8]	[9]	[10]	[11]

- [1] Output speed
- [2] Maximum permissible output torque
- [3] Calculated maximum input power rating of the gear unit
- [4] Maximum permissible overhung load at the midpoint of a solid output shaft assuming maximum output torque
- [5] Maximum permissible overhung load at the midpoint of the input shaft
- [6] Number of gear stages within a single gear unit or within the larger gear unit of a compound
- [7] Number of gear stages within the smaller gear unit of a compound (R..)
- [8] When the reduced backlash (/R) option is possible, the value shown is the circumferential backlash in angular minutes ['] for the reduced backlash version. When no data is given (-), the reduced backlash option (/R) is not possible for this ratio.
- [9] Some mounting positions invoke additional heat due to oil churning losses. The mounting position that may limit the input power rating will be shown. For additional information, see section, "Thermal limitations with AD input" on page 63.
- [10] Gear unit size
- [11] Cover size

Weights

The weights of the gear units with AD input are shown at the bottom of the selection table for each gear unit, as shown below.

Weight [lbs]	Stages		AD2	AD3	AD4	AD5
	Large	Small				
R87	2	-	132	141	154	187
	3	-	135	144	157	190
RF87: +15 lbs / RM87: +80 lbs						

8 R / RX - Helical

8.1 R/RX.. AM

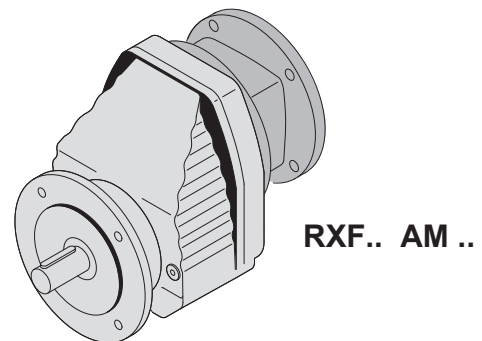
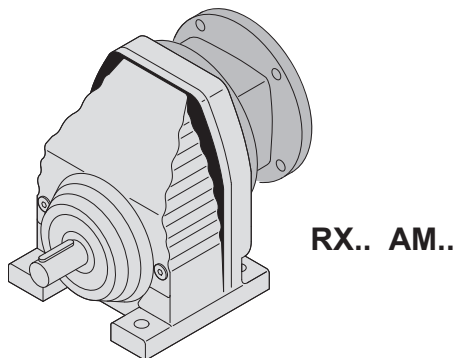
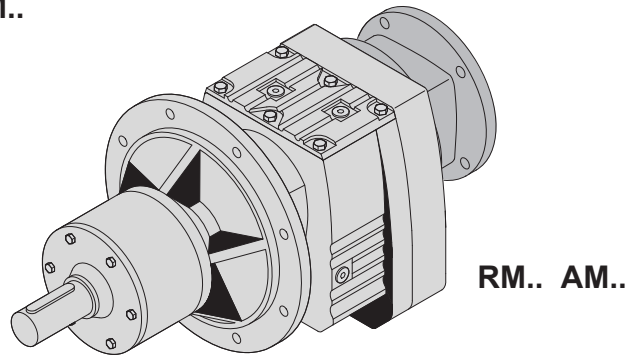
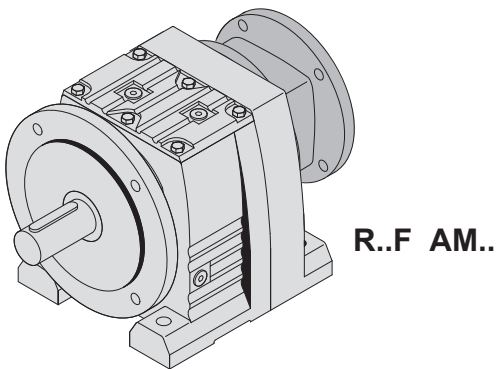
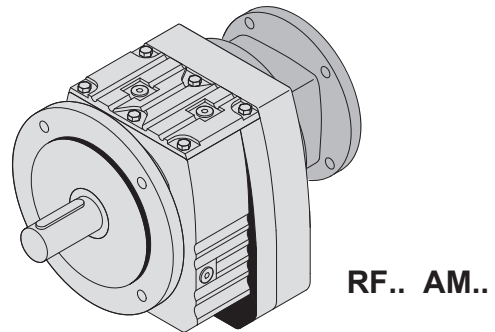
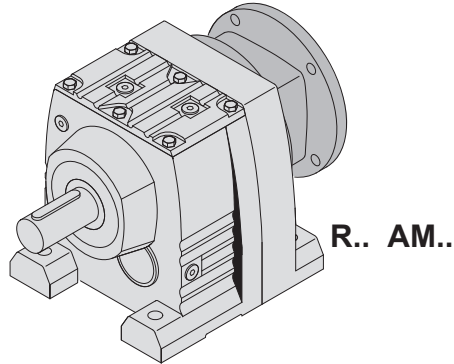

8

50392AXX

8.1.1 RX57

RX57, $n_e = 1700$ rpm						610 lb-in					
Stages	i [ratio]	n_a [rpm]	T_a max [lb-in]	F_{Ra} [lb]	Φ (/R) [']	AM					
						56	143	145	182	184	213/215
RX57  1	1.30	1310	555	0	-						
	1.48	1150	600	0	-						
	1.65	1030	610	27	-						
	1.92	885	610	126	-						
	2.04	833	610	166	-						
	2.37	717	610	260	-						
	2.64	644	610	325	-						
	2.91	584	590	405	-						
	3.14	541	575	480	-						
	3.55	479	610	500	-						
	3.79	449	610	515	-						
	4.35	391	600	550	-						
	5.07	335	315	635	-						
5.50	309	345	650	-							

Weight [lbs]		Stages	AM					
			56	143	145	182	184	213/215
RX57	NEMA	1	29	33	33	41	41	53
			71	80	90	100	112	132S/M
	IEC	1	28	33	33	43	43	59

RXF57: + 4.0 lbs

8.1.2 RX67

RX67, $n_e = 1700$ rpm						1180 lb-in					
Stages	i [ratio]	n_a [rpm]	T_a max [lb-in]	F_{Ra} [lb]	Φ (/R) [']	AM					
						56	143	145	182	184	213/215
RX67  1	1.40	1215	920	0	-						
	1.61	1055	1000	0	-						
	1.86	914	1110	0	-						
	2.04	833	1180	0	-						
	2.40	708	1080	235	-						
	2.54	669	1040	340	-						
	2.89	588	930	545	-						
	3.20	531	880	580	-						
	3.77	451	765	640	-						
	4.30	395	705	685	-						
	4.53	375	725	700	-						
	5.18	328	660	745	-						
	6.07	280	380	840	-						

Weight [lbs]		Stages	AM					
			56	143	145	182	184	213/215
RX67	NEMA	1	34	38	39	47	47	59
			71	80	90	100	112	132S/M
	IEC	1	34	38	39	49	49	64

RXF67: + 9.0 lbs

8.1.3 RX77

RX77, n _e = 1700 rpm						1900 lb-in					
Stages	i [ratio]	n _a [rpm]	T _a max [lb-in]	F _{Ra} [lb]	Φ (/R) [']	AM					
						56	143	145	182	184	213/215
 1	1.42	1195	1370	0	-						
	1.67	1020	1530	0	-						
	1.88	904	1650	0	-						
	2.13	798	1760	0	-						
	2.43	700	1900	0	-						
	2.70	630	1900	121	-						
	3.08	552	1700	440	-						
	3.25	523	1610	580	-						
	3.70	459	1350	890	-						
	4.04	421	1260	940	-						
	4.73	359	1080	1020	-						
	5.35	318	910	1100	-						
	5.63	302	970	1110	-						
	6.41	265	910	1170	-						
7.47	228	465	1300	-							
8.00	212	500	1330	-							

Weight [lbs]		Stages	AM					
RX77			56	143	145	182	184	213/215
NEMA		1	56	60	60	67	68	81
			71	80	90	100	112	132S/M
IEC		1	55	60	60	70	70	85

RXF77: + 5.0 lbs

8.1.4 RX87

RX87, n _e = 1700 rpm						3580 lb-in						
Stages	i [ratio]	n _a [rpm]	T _a max [lb-in]	F _{Ra} [lb]	Φ (/R) [']	AM						
						143	145	182	184	213/215	254/256	284/286
 1	1.39	1225	2560	0	-							
	1.60	1060	2780	0	-							
	1.93	881	3140	0	-							
	2.15	791	3400	0	-							
	2.48	685	3580	0	-							
	2.76	616	3580	91	-							
	3.09	550	3580	255	-							
	3.48	489	3580	420	-							
	3.78	450	2690	1040	-							
	4.50	378	2560	1140	-							
	5.07	335	2210	1240	-							
	5.56	306	1990	1320	-							
	6.45	264	1690	1430	-							
	7.20	236	1230	1540	-							
7.63	223	1310	1570	-								
8.65	197	1220	1650	-								

Weight [lbs]		Stages	AM							
RX87			143	145	182	184	213/215	254/256	284/286	
NEMA		1	95	95	105	105	120	145	150	
			80	90	100	112	132S/M	160	180	
IEC		1	95	95	105	105	125	160	160	

RXF87: + 11 lbs

8.1.5 RX97

RX97, $n_e = 1700$ rpm						5270 lb-in						
Stages	i [ratio]	n_a [rpm]	$T_{a\ max}$ [lb-in]	F_{Ra} [lb]	ϕ (/R) [']	AM						
						182	184	213/215	254/256	284/286	324/326	364/365
 1	1.42	1195	4020	0	-							
	1.64	1035	4460	0	-							
	1.96	867	5040	0	-							
	2.24	759	5270	0	-							
	2.64	644	5270	225	-							
	2.92	582	5270	405	-							
	3.30	515	5270	605	-							
	3.64	467	5270	775	-							
	4.04	421	5270	960	-							
	4.52	376	5270	1150	-							
	4.91	346	3490	1500	-							
	5.79	294	3710	1580	-							
	6.56	259	2650	1770	-							
	7.16	237	2300	1870	-							
8.23	207	1990	2000	-								

Weight [lbs]		Stages	AM						
			182	184	213/215	254/256	284/286	324/326	364/365
RX97	NEMA	1	160	160	170	205	205	245	245
			100	112	132S/M	160	180	200	225
	IEC	1	160	160	175	215	215	250	260

RXF97: + 19 lbs



8.1.6 RX107

RX107, $n_e = 1700$ rpm						7350 lb-in						
Stages	i [ratio]	n_a [rpm]	$T_{a\ max}$ [lb-in]	F_{Ra} [lb]	ϕ (/R) [']	AM						
						182	184	213/215	254/256	284/286	324/326	364/365
 1	1.44	1180	5700	0	-							
	1.71	994	6230	0	-							
	1.95	872	6760	0	-							
	2.30	739	7350	0	-							
	2.64	644	7350	240	-							
	3.07	554	7350	545	-							
	3.38	503	7350	740	-							
	3.81	446	7350	970	-							
	4.20	405	7350	1150	-							
	4.65	366	6140	1530	-							
	5.19	328	6140	1610	-							
	5.61	303	4020	1890	-							
	6.63	256	4070	2020	-							

Weight [lbs]		Stages	AM						
			182	184	213/215	254/256	284/286	324/326	364/365
RX107	NEMA	1	230	230	235	270	275	315	315
			100	112	132S/M	160	180	200	225
	IEC	1	235	235	240	285	285	320	330

RXF107: + 37 lbs



8.1.7 R27

R27, n _e = 1700 rpm						1150 lb-in		
Stages	i [ratio]	n _a [rpm]	T _{a max} [lb-in]	F _{Ra} [lb]	φ (/R) [']	AM		
						56	143	145
R27  2	3.37	504	695	152	-			
	4.00	425	750	151	-			
	4.27	398	765	153	-			
	5.00	340	840	136	-			
	5.60	304	870	139	-			
	6.59	258	930	136	-			
	7.63	223	990	137	-			
	8.16	208	1020	129	-			
	9.41	181	1070	133	-			
	10.13	168	1070	355	-			
	11.86	143	1140	370	-			
	13.28	128	1150	410	-			
	15.63	109	1150	475	-			
	18.08	94	1150	505	-			
	19.35	88	1150	520	-			
	22.32	76	1150	550	-			
	26.09	65	1150	590	-			
	28.37	60	1150	610	-			
R27  3	24.47	69	1150	575	-			
	28.78	59	1150	615	-			
	32.47	52	1150	645	-			
	36.79	46	1150	680	-			
	39.25	43	1150	695	-			
	44.90	38	1150	735	-			
	48.17	35	1150	755	-			
	55.87	30	1150	800	-			
	61.30	28	1150	830	-			
	69.47	24	1150	870	-			
	74.11	23	1150	890	-			
	84.78	20	1150	940	-			
	90.96	19	1150	950	-			
	105.49	16	1150	950	-			
	123.91	14	1150	950	-			
135.09	13	1150	950	-				

8

Weight [lbs]		Stages	56	AM 143	145
R27	NEMA	2	15	20	20
		3	16	20	20
			71	80	90
	IEC	2	14	20	20
		3	15	20	20
	RF27: + 0 lbs				

8.1.8 R37

R37, n_e = 1700 rpm						1770 lb-in		
Stages	i [ratio]	n _a [rpm]	T _{a max} [lb-in]	F _{Ra} [lb]	φ _(/R) [']	AM		
						56	143	145
R37 	3.41	499	990	138	14			
	4.05	420	1070	121	13			
	4.32	394	1110	114	13			
	5.06	336	1190	104	13			
	5.67	300	1250	94	12			
	6.67	255	1270	144	12			
	7.97	213	1380	300	8			
	9.47	180	1470	305	8			
	10.11	168	1500	315	8			
	11.83	144	1610	310	8			
	13.25	128	1680	320	8			
	15.60	109	1770	345	8			
	18.05	94	1770	425	8			
	19.31	88	1770	460	7			
	22.27	76	1770	545	7			
	26.03	65	1630	740	7			
28.32	60	1770	700	7				
R37 	24.42	70	1770	605	9			
	28.73	59	1770	705	9			
	32.40	52	1770	790	9			
	36.72	46	1770	880	9			
	39.17	43	1770	920	9			
	44.81	38	1770	1020	9			
	48.08	35	1770	1080	9			
	55.76	30	1770	1110	9			
	61.18	28	1770	1110	8			
	69.33	25	1770	1110	8			
	73.96	23	1770	1110	8			
	84.61	20	1770	1110	8			
	90.77	19	1770	1110	8			
	105.28	16	1770	1110	8			
	123.66	14	1770	1110	8			
	134.82	13	1770	1110	8			

Weight [lbs]		Stages	56	AM 143	145
R37	NEMA	2	28	32	33
		3	28	33	33
			71	80	90
	IEC	2	27	32	33
		3	28	33	33

RF37: + 3.5 lbs

8.1.9 R47

R47, n _e = 1700 rpm						2650 lb-in					
Stages	i [ratio]	n _a [rpm]	T _{a max} [lb-in]	F _{Ra} [lb]	Φ (/R) [']	AM					
						56	143	145	182	184	213/215
R47  2	3.83	444	1270	430	11						
	4.34	392	1290	455	11						
	4.85	351	1320	470	10						
	5.64	301	1370	500	10						
	6.00	283	1380	510	10						
	6.96	244	1400	540	10						
	7.76	219	1440	565	10						
	8.01	212	1810	555	8						
	9.07	187	1940	550	8						
	10.15	167	2030	565	7						
	11.79	144	2160	575	7						
	12.54	136	2210	590	7						
	14.56	117	2340	605	7						
	16.22	105	2430	625	7						
	17.89	95	2560	615	7						
	19.27	88	2610	640	7						
	21.81	78	2650	710	7						
	23.28	73	2650	760	7						
	26.74	64	2650	840	7						
31.12	55	1940	960	7							
33.79	50	2120	970	7							
23.59	72	2650	775	8							
26.70	64	2650	840	8							
29.88	57	2650	880	8							
34.73	49	2650	940	8							
36.93	46	2650	960	8							
42.87	40	2650	1020	8							
47.75	36	2650	1070	8							
52.69	32	2650	1110	8							
56.73	30	2650	1150	8							
64.21	26	2650	1200	8							
68.54	25	2650	1220	8							
76.23	22	2650	1220	7							
84.90	20	2650	1220	7							
93.68	18	2650	1220	7							
100.86	17	2650	1220	7							
114.17	15	2650	1220	7							
121.87	14	2650	1220	7							
139.99	12	2650	1220	7							
162.94	10	2650	1220	7							
176.88	9.6	2650	1220	7							

8

Weight [lbs]		Stages	AM					
			56	143	145	182	184	213/215
R47	NEMA	2	37	41	41	49	49	62
		3	38	42	42	50	50	63
			71	80	90	100	112	132S/M
	IEC	2	36	41	41	51	51	67
3		37	42	42	53	53	68	

RF47: + 0 lbs

8.1.10 R47R37



R47R37, n_e = 1700 rpm							2650 lb-in		
i	n_a	T_{a max}	F_{Ra}¹⁾	Stages		φ (/R)	AM		
				Lg	Sm		56	143	145
[ratio]	[rpm]	[lb-in]	[lb]			[']			
98	17	2650	1220	2	2	-			
109	16	2650	1220	2	2	-			
129	13	2650	1220	2	2	-			
154	11	2650	1220	2	2	-			
182	9.3	2650	1220	2	2	-			
195	8.7	2650	1220	2	2	-			
228	7.5	2650	1220	2	2	-			
255	6.7	2650	1220	2	2	-			
301	5.6	2650	1220	2	2	-			
344	4.9	2650	1220	3	2	-			
348	4.9	2650	1220	2	2	-			
372	4.6	2650	1220	2	2	-			
408	4.2	2650	1220	3	2	-			
429	4.0	2650	1220	2	2	-			
436	3.9	2650	1220	3	2	-			
471	3.6	2650	1220	2	3	-			
502	3.4	2650	1220	2	2	-			
510	3.3	2650	1220	3	2	-			
546	3.1	2650	1220	2	2	-			
554	3.1	2650	1220	2	3	-			
572	3.0	2650	1220	3	2	-			
624	2.7	2650	1220	2	3	-			
673	2.5	2650	1220	3	2	-			
708	2.4	2650	1220	2	3	-			
755	2.3	2650	1220	2	3	-			
804	2.1	2650	1220	3	2	-			
863	2.0	2650	1220	2	3	-			
927	1.8	2650	1220	2	3	-			
955	1.8	2650	1220	3	2	-			
1020	1.7	2650	1220	3	2	-			
1074	1.6	2650	1220	2	3	-			
1179	1.4	2650	1220	2	3	-			
1193	1.4	2650	1220	3	2	-			
1336	1.3	2650	1220	2	3	-			
1425	1.2	2650	1220	2	3	-			
1573	1.1	2650	1220	3	2	-			
1630	1.0	2650	1220	2	3	-			
1749	0.97	2650	1220	2	3	-			
1821	0.93	2650	1220	3	2	-			
1948	0.87	2650	1220	3	2	-			
2029	0.84	2650	1220	2	3	-			
2246	0.76	2650	1220	3	2	-			
2383	0.71	2650	1220	2	3	-			
2463	0.69	2650	1220	3	3	-			
2598	0.65	2650	1220	2	3	-			
2625	0.65	2650	1220	3	2	-			
2856	0.60	2650	1220	3	2	-			
2898	0.59	2650	1220	3	3	-			
3268	0.52	2650	1220	3	3	-			
3704	0.46	2650	1220	3	3	-			
3951	0.43	2650	1220	3	3	-			

R47R37, n_e = 1700 rpm 2650 lb-in

i [ratio]	n _a [rpm]	T _{a max} [lb-in]	F _{Ra} ¹⁾ [lb]	Stages		φ (R) [']	56	AM	
				Lg	Sm			143	145
4520	0.38	2650	1220	3	3	-			
4849	0.35	2650	1220	3	3	-			
5624	0.30	2650	1220	3	3	-			
6171	0.28	2650	1220	3	3	-			
6993	0.24	2650	1220	3	3	-			
7460	0.23	2650	1220	3	3	-			
8534	0.20	2650	1220	3	3	-			
9155	0.19	2650	1220	3	3	-			
10619	0.16	2650	1220	3	3	-			
12472	0.14	2650	1220	3	3	-			
13598	0.13	2650	1220	3	3	-			

Weight [lbs]		Stages		56	AM	
		Large	Small		143	145
R47R37	NEMA	2	2	60	64	64
		2	3	60	65	65
		3	2	61	66	66
		3	3	62	66	66
				71	80	90
	IEC	2	2	59	64	64
		2	3	60	65	65
		3	2	60	66	66
		3	3	61	66	66
RF47: +0 lbs						

8.1.11 R57

R57, n _e = 1700 rpm						3980 lb-in					
Stages	i [ratio]	n _a [rpm]	T _{a max} [lb-in]	F _{Ra} [lb]	Φ (i/R) [']	AM					
						56	143	145	182	184	213/215
R57  2	4.39	387	2470	315	10						
	5.05	337	2690	270	10						
	5.82	292	2830	285	10						
	6.41	265	2960	270	9						
	7.53	226	3090	300	9						
	7.97	213	3140	315	9						
	9.06	188	3310	305	9						
	9.35	182	3270	615	7						
	10.79	158	3450	635	7						
	11.88	143	3580	645	7						
	13.95	122	3800	670	7						
	14.77	115	3840	695	7						
	16.79	101	3980	745	7						
	18.60	91	3980	830	7						
	21.93	78	3980	900	7						
	24.99	68	3980	950	6						
	26.31	65	3980	980	6						
R57  3	26.97	63	3980	990	8						
	30.18	56	3980	1040	8						
	35.07	48	3980	1110	8						
	37.30	46	3980	1140	8						
	43.30	39	3980	1220	8						
	48.23	35	3980	1280	8						
	53.22	32	3980	1330	8						
	57.29	30	3980	1370	8						
	64.85	26	3980	1450	8						
	69.23	25	3980	1490	7						
	80.55	21	3980	1580	7						
	89.71	19	3980	1600	7						
	98.99	17	3980	1600	7						
	106.58	16	3980	1600	7						
	120.63	14	3980	1600	7						
	128.77	13	3980	1600	7						
	147.92	11	3980	1600	7						
172.17	9.9	3980	1600	7							
186.89	9.1	3980	1600	7							

Weight [lbs]		Stages	AM					
			56	143	145	182	184	213/215
R57	NEMA	2	47	52	52	60	60	72
		3	50	54	54	62	62	74
			71	80	90	100	112	132S/M
	IEC	2	47	52	52	62	62	78
		3	49	54	54	64	64	80

RF57: + 7.5 lbs / RM57: +34 lbs

8.1.12 R57R37

R57R37, $n_e = 1700$ rpm							3980 lb-in		
i [ratio]	n_a [rpm]	$T_{a \max}$ [lb-in]	$F_{Ra}^{1)}$ [lb]	Stages		ϕ (/R) [']	56	AM	
				Lg	Sm			143	145
134	13	3980	1600	2	2	-			
142	12	3980	1600	3	2	-			
146	12	3980	1600	2	2	-			
159	11	3980	1600	2	2	-			
164	10	3980	1600	3	2	-			
187	9.1	3980	1600	3	2	-			
188	9.0	3980	1600	2	2	-			
215	7.9	3980	1600	3	2	-			
220	7.7	3980	1600	2	2	-			
241	7.1	3980	1600	3	2	-			
246	6.9	3980	1600	2	2	-			
262	6.5	3980	1600	2	2	-			
273	6.2	3980	1600	3	2	-			
290	5.9	3980	1600	2	2	-			
319	5.3	3980	1600	3	2	-			
324	5.2	3980	1600	2	2	-			
357	4.8	3980	1600	3	2	-			
359	4.7	3980	1600	2	2	-			
410	4.1	3980	1600	2	3	-			
454	3.7	3980	1600	2	3	-			
471	3.6	3980	1600	3	2	-			
534	3.2	3980	1600	2	3	-			
537	3.2	3980	1600	3	2	-			
603	2.8	3980	1600	2	3	-			
604	2.8	3980	1600	3	2	-			
678	2.5	3980	1600	3	2	-			
683	2.5	3980	1600	2	3	-			
782	2.2	3980	1600	3	2	-			
805	2.1	3980	1600	2	3	-			
894	1.9	3980	1600	2	3	-			
1027	1.7	3980	1600	2	3	-			
1034	1.6	3980	1600	3	2	-			
1164	1.5	3980	1600	2	3	-			
1189	1.4	3980	1600	3	2	-			
1342	1.3	3980	1600	2	3	-			
1399	1.2	3980	1600	3	2	-			
1520	1.1	3980	1600	2	3	-			
1555	1.1	3980	1600	3	2	-			
1732	0.98	3980	1600	3	2	-			
1768	0.96	3980	1600	2	3	-			
1967	0.86	3980	1600	3	3	-			
1991	0.85	3980	1600	2	3	-			
2244	0.76	3980	1600	3	3	-			
2309	0.74	3980	1600	2	3	-			
2508	0.68	3980	1600	2	3	-			
2567	0.66	3980	1600	3	3	-			
2907	0.58	3980	1600	3	3	-			
2957	0.57	3980	1600	2	3	-			
3344	0.51	3980	1600	3	3	-			
3873	0.44	3980	1600	3	3	-			
4378	0.39	3980	1600	3	3	-			

8



R57R37, n_e = 1700 rpm 3980 lb-in

i [ratio]	n _a [rpm]	T _{a max} [lb-in]	F _{Ra} ¹⁾ [lb]	Stages		φ (R) [']	56	AM	
				Lg	Sm			143	145
4928	0.34	3980	1600	3	3	-			
5585	0.30	3980	1600	3	3	-			
6521	0.26	3980	1600	3	3	-			
7312	0.23	3980	1600	3	3	-			
8480	0.20	3980	1600	3	3	-			
9445	0.18	3980	1600	3	3	-			
10860	0.16	3980	1600	3	3	-			
12095	0.14	3980	1600	3	3	-			
14369	0.12	3980	1600	3	3	-			

Weight [lbs]		Stages		56	AM		
		Large	Small		143	145	
R57R37	NEMA	2	2	71	75	75	
		2	3	71	76	76	
		3	2	73	77	77	
		3	3	73	78	78	
					71	80	90
	IEC	2	2	70	75	75	
		2	3	70	76	76	
		3	2	72	77	77	
		3	3	72	78	78	

RF57: +7.5 lbs / RM57 +34 lbs

8.1.13 R67

R67, n _e = 1700 rpm						5310 lb-in					
Stages	i [ratio]	n _a [rpm]	T _{a max} [lb-in]	F _{Ra} [lb]	Φ (i/R) [']	AM					
						56	143	145	182	184	213/215
R67  2	4.29	396	2380	1040	10						
	4.93	345	2560	1080	9						
	5.70	298	2740	1130	9						
	6.27	271	2910	1150	9						
	7.36	231	3270	1100	8						
	7.79	218	3360	1110	8						
	8.70	195	3890	1190	7						
	10.00	170	4150	1200	7						
	11.54	147	4420	1230	7						
	12.70	134	4600	1260	6						
	14.91	114	4860	1320	6						
	15.79	108	4950	1350	6						
	17.95	95	5220	1380	6						
	19.89	85	5300	1470	6						
	23.44	73	4950	1760	6						
	26.72	64	4770	1850	6						
	28.13	60	4770	1850	6						
R67  3	28.83	59	4600	1890	7						
	32.27	53	4770	1850	7						
	37.50	45	5040	1780	7						
	39.88	43	5130	1750	7						
	46.29	37	5310	1700	7						
	51.56	33	5310	1700	7						
	56.89	30	5310	1700	7						
	61.26	28	5310	1700	7						
	69.75	24	5310	1700	7						
	74.17	23	5310	1700	7						
	86.11	20	5310	1700	6						
	95.91	18	5310	1700	6						
	105.83	16	5310	1700	6						
	113.94	15	5310	1700	6						
	128.97	13	5310	1700	6						
	137.67	12	5310	1700	6						
	158.14	11	5310	1700	6						
184.07	9.2	5310	1700	6							
199.81	8.5	5310	1700	6							

8

Weight [lbs]		Stages	AM					
			56	143	145	182	184	213/215
R67	NEMA	2	62	66	66	74	74	87
		3	64	68	68	76	76	89
			71	80	90	100	112	132S/M
	IEC	2	61	66	66	77	77	92
3		63	68	68	79	79	94	

RF67: + 7 lbs / RM67: +42 lbs

8.1.14 R67R37

R67R37, n_e = 1700 rpm							5310 lb-in		
i	n_a	T_{a max}	F_{Ra}¹⁾	Stages		Φ_(/R)	AM		
				Lg	Sm		56	143	145
158	11	5310	1700	3	2	-			
159	11	5310	1700	2	2	-			
176	9.7	5310	1700	3	2	-			
181	9.4	5310	1700	2	2	-			
200	8.5	5310	1700	3	2	-			
201	8.5	5310	1700	2	2	-			
234	7.3	5310	1700	3	2	-			
235	7.2	5310	1700	2	2	-			
261	6.5	5310	1700	3	2	-			
264	6.4	5310	1700	2	2	-			
294	5.8	5310	1700	3	2	-			
310	5.5	5310	1700	2	2	-			
344	4.9	5310	1700	3	2	-			
359	4.7	5310	1700	2	2	-			
384	4.4	5310	1700	2	2	-			
388	4.4	5310	1700	3	2	-			
438	3.9	5310	1700	3	2	-			
443	3.8	5310	1700	2	2	-			
486	3.5	5310	1700	2	3	-			
495	3.4	5310	1700	3	2	-			
571	3.0	5310	1700	2	3	-			
574	3.0	5310	1700	3	2	-			
644	2.6	5310	1700	2	3	-			
646	2.6	5310	1700	3	2	-			
730	2.3	5310	1700	2	3	-			
750	2.3	5310	1700	3	2	-			
836	2.0	5310	1700	3	2	-			
891	1.9	5310	1700	2	3	-			
956	1.8	5310	1700	2	3	-			
1106	1.5	5310	1700	3	2	-			
1109	1.5	5310	1700	2	3	-			
1259	1.4	5310	1700	3	2	-			
1379	1.2	5310	1700	2	3	-			
1432	1.2	5310	1700	3	2	-			
1471	1.2	5310	1700	2	3	-			
1629	1.0	5310	1700	2	3	-			
1652	1.0	5310	1700	3	2	-			
1805	0.94	5310	1700	2	3	-			
1852	0.92	5310	1700	3	2	-			
2094	0.81	5310	1700	2	3	-			
2136	0.80	5310	1700	3	2	-			
2403	0.71	5310	1700	3	3	-			
2460	0.69	5310	1700	2	3	-			
2682	0.63	5310	1700	2	3	-			
2745	0.62	5310	1700	3	3	-			
3125	0.54	5310	1700	3	3	-			
3566	0.48	5310	1700	3	3	-			
4136	0.41	5310	1700	3	3	-			
4680	0.36	5310	1700	3	3	-			
5268	0.32	5310	1700	3	3	-			
5970	0.28	5310	1700	3	3	-			



R67R37, n_e = 1700 rpm 5310 lb-in

i [ratio]	n _a [rpm]	T _{a max} [lb-in]	F _{Ra} ¹⁾ [lb]	Stages		φ (/R) [']	56	AM	
				Lg	Sm			143	145
6732	0.25	5310	1700	3	3	-			
7816	0.22	5310	1700	3	3	-			
9066	0.19	5310	1700	3	3	-			
10097	0.17	5310	1700	3	3	-			
11996	0.14	5310	1700	3	3	-			
12931	0.13	5310	1700	3	3	-			
15361	0.11	5310	1700	3	3	-			

Weight [lbs]		Stages		56	AM	
		Large	Small		143	145
R67R37	NEMA	2	2	85	90	90
		2	3	86	90	90
		3	2	87	92	92
		3	3	88	92	92
				71	80	90
	IEC	2	2	84	90	90
		2	3	85	90	90
		3	2	86	92	92
		3	3	87	92	92

RF67: + 7 lbs / RM67: + 42 lbs

8.1.15 R77

R77, n _e = 1700 rpm						7260 lb-in					
Stages	i [ratio]	n _a [rpm]	T _{a max} [lb-in]	F _{Ra} [lb]	Φ (i/R) [']	AM					
						56	143	145	182	184	213/215
R77  2	5.31	320	4510	710	8						
	5.99	284	4770	700	8						
	6.79	250	5130	660	8						
	7.74	220	5390	675	8						
	8.59	198	5570	705	7						
	9.64	176	5570	1190	7						
	10.88	156	5830	1220	6						
	12.33	138	6100	1270	6						
	14.05	121	6370	1330	6						
	15.60	109	6540	1390	6						
	17.82	95	6900	1430	6						
	18.80	90	6900	1510	6						
	21.43	79	7260	1560	6						
	23.37	73	7260	1690	6						
R77  3	25.23	67	6900	1950	7						
	29.00	59	7260	2030	7						
	33.47	51	7260	2230	7						
	36.83	46	7260	2230	7						
	43.26	39	7260	2230	7						
	45.81	37	7260	2230	7						
	52.07	33	7260	2230	7						
	57.68	29	7260	2230	7						
	65.77	26	7260	2230	7						
	77.24	22	7260	2230	6						
	81.80	21	7260	2230	6						
	92.97	18	7260	2230	6						
	102.99	17	7260	2230	6						
	121.42	14	7260	2230	6						
	138.39	12	7260	2230	6						
	145.67	12	7260	2230	6						
166.59	10	7260	2230	6							
195.24	8.7	7260	2230	6							

Weight [lbs]		Stages	AM					
			56	143	145	182	184	213/215
R77	NEMA	2	75	79	79	86	87	100
		3	77	81	81	89	89	100
	IEC		71	80	90	100	112	132S/M
		2	74	79	79	89	89	105
		3	76	81	81	91	91	105

RF77: + 13 lbs / RM77: +68 lbs

8.1.16 R77R37

R77R37, n _e = 1700 rpm							7260 lb-in		
i [ratio]	n _a [rpm]	T _{a max} [lb-in]	F _{Ra} ¹⁾ [lb]	Stages		Φ (/R) [']	AM		
				Lg	Sm		56	143	145
149	11	7260	2230	3	2	-			
169	10	7260	2230	3	2	-			
186	9.1	7260	2230	2	2	-			
197	8.6	7260	2230	3	2	-			
221	7.7	7260	2230	2	2	-			
224	7.6	7260	2230	3	2	-			
236	7.2	7260	2230	2	2	-			
260	6.5	7260	2230	3	2	-			
276	6.2	7260	2230	2	2	-			
289	5.9	7260	2230	3	2	-			
310	5.5	7260	2230	2	2	-			
327	5.2	7260	2230	3	2	-			
365	4.7	7260	2230	2	2	-			
373	4.6	7260	2230	3	2	-			
422	4.0	7260	2230	2	2	-			
436	3.9	7260	2230	3	2	-			
451	3.8	7260	2230	2	2	-			
488	3.5	7260	2230	3	2	-			
520	3.3	7260	2230	2	2	-			
560	3.0	7260	2230	3	2	-			
571	3.0	7260	2230	2	3	-			
646	2.6	7260	2230	3	2	-			
671	2.5	7260	2230	2	3	-			
731	2.3	7260	2230	3	2	-			
757	2.2	7260	2230	2	3	-			
821	2.1	7260	2230	3	2	-			
858	2.0	7260	2230	2	3	-			
915	1.9	7260	2230	2	3	-			
940	1.8	7260	2230	3	2	-			
1047	1.6	7260	2230	2	3	-			
1084	1.6	7260	2230	3	2	-			
1124	1.5	7260	2230	2	3	-			
1218	1.4	7260	2230	3	2	-			
1303	1.3	7260	2230	2	3	-			
1394	1.2	7260	2230	3	2	-			
1430	1.2	7260	2230	2	3	-			
1580	1.1	7260	2230	3	2	-			
1620	1.0	7260	2230	2	3	-			
1728	0.98	7260	2230	2	3	-			
1822	0.93	7260	2230	3	2	-			
1977	0.86	7260	2230	2	3	-			
2070	0.82	7260	2230	3	2	-			
2121	0.80	7260	2230	2	3	-			
2345	0.72	7260	2230	3	2	-			
2460	0.69	7260	2230	2	3	-			
2671	0.64	7260	2230	3	3	-			
2890	0.59	7260	2230	2	3	-			
3053	0.56	7260	2230	3	3	-			
3151	0.54	7260	2230	2	3	-			
3488	0.49	7260	2230	3	3	-			
3999	0.43	7260	2230	3	3	-			

8

8 R / RX - Helical

R/RX.. AM

R77R37, $n_e = 1700$ rpm 7260 lb-in

i [ratio]	n_a [rpm]	T_a max [lb-in]	$F_{Ra}^{1)}$ [lb]	Stages		ϕ (/R) [']	56	AM	
				Lg	Sm			143	145
4470	0.38	7260	2230	3	3	-			
5184	0.33	7260	2230	3	3	-			
5838	0.29	7260	2230	3	3	-			
6770	0.25	7260	2230	3	3	-			
7617	0.22	7260	2230	3	3	-			
8714	0.20	7260	2230	3	3	-			
9788	0.17	7260	2230	3	3	-			
11021	0.15	7260	2230	3	3	-			
12783	0.13	7260	2230	3	3	-			
13885	0.12	7260	2230	3	3	-			
15015	0.11	7260	2230	3	3	-			
16370	0.10	7260	2230	3	3	-			

Weight [lbs]		Stages		56	AM		
		Large	Small		143	145	
R77R37	NEMA	2	2	97	100	100	
		2	3	97	100	100	
		3	2	99	105	105	
		3	3	100	105	105	
					71	80	90
	IEC	2	2	96	100	100	
		2	3	96	100	100	
		3	2	98	105	105	
		3	3	99	105	105	

RF77: + 13 lbs / RM77: + 68 lbs

8.1.17 R87

R87, n _e = 1700 rpm						13700 lb-in						
Stages	i [ratio]	n _a [rpm]	T _{a max} [lb-in]	F _{Ra} [lb]	Φ (/R) [']	AM						
						143	145	182	184	213/215	254/256	284/286
R87  2	5.30	321	8050	1870	7							
	6.39	266	9020	1960	7							
	7.13	238	9460	2030	7							
	8.22	207	10200	2110	7							
	9.14	186	10700	2190	6							
	9.90	172	10400	2150	6							
	11.93	142	10800	2310	6							
	13.33	128	11300	2390	6							
	15.35	111	11800	2510	6							
	17.08	100	12200	2600	6							
	19.10	89	12700	2700	6							
	21.51	79	13200	2810	6							
	23.40	73	13700	2880	6							
	27.84	61	13700	3100	6							
31.40	54	13700	1330	5								
34.40	49	13200	1690	5								
27.88	61	13200	3130	7								
32.66	52	13700	3320	7								
36.84	46	13700	3490	7								
41.74	41	13700	3670	7								
47.58	36	13700	3800	7								
52.82	32	13700	2540	6								
60.35	28	13700	2880	6								
63.68	27	13700	3020	6								
72.57	23	13700	3380	6								
81.92	21	13700	3730	6								
93.38	18	13700	3800	6								
103.65	16	13700	3800	6								
118.43	14	13700	3800	6								
124.97	14	13700	3800	6								
142.41	12	13700	3800	6								
155.34	11	13700	3800	6								
181.77	9.4	13700	3800	6								
205.71	8.3	13700	3800	6								
216.54	7.9	13700	3800	6								
246.54	6.9	13700	3800	6								

8

Weight [lbs]		Stages	AM						
			143	145	182	184	213/215	254/256	284/286
R87	NEMA	2	135	135	145	145	160	190	195
		3	140	140	150	150	160	190	195
			80	90	100	112	132S/M	160	180
	IEC	2	135	135	145	145	165	200	200
3		140	140	150	150	165	200	205	

RF87: + 16 lbs / RM87: +81 lbs

8.1.18 R87R57

R87R57, n_e = 1700 rpm							13720 lb-in					
i [ratio]	n _a [rpm]	T _{a max} [lb-in]	F _{Ra} ¹⁾ [lb]	Stages		Φ (i/R) [']	AM					
				Lg	Sm		56	143	145	182	184	213/215
195	8.7	13720	3810	2	2	-						
209	8.1	13720	3810	3	2	-						
232	7.3	13720	3810	2	2	-						
236	7.2	13720	3810	3	2	-						
256	6.6	13720	3810	2	2	-						
268	6.3	13720	3810	3	2	-						
300	5.7	13720	3810	2	2	-						
305	5.6	13720	3810	3	2	-						
352	4.8	13720	3810	3	2	-						
361	4.7	13720	3810	2	2	-						
398	4.3	13720	3810	3	2	-						
400	4.3	13720	3810	2	2	-						
456	3.7	13720	3810	3	2	-						
472	3.6	13720	3810	2	2	-						
525	3.2	13720	3810	3	2	-						
538	3.2	13720	3810	2	2	-						
580	2.9	13720	3810	2	3	-						
599	2.8	13720	3810	3	2	-						
649	2.6	13720	3810	2	3	-						
685	2.5	13720	3810	3	2	-						
754	2.3	13720	3810	2	3	-						
776	2.2	13720	3810	3	2	-						
802	2.1	13720	3810	2	3	-						
881	1.9	13720	3810	3	3	-						
885	1.9	13720	3810	3	2	-						
931	1.8	13720	3810	2	3	-						
994	1.7	13720	3810	3	3	-						
1008	1.7	13720	3810	3	2	-						
1037	1.6	13720	3810	2	3	-						
1143	1.5	13720	3810	3	2	-						
1145	1.5	13720	3810	2	3	-						
1232	1.4	13720	3810	2	3	-						
1303	1.3	13720	3810	3	2	-						
1395	1.2	13720	3810	2	3	-						
1489	1.1	13720	3810	2	3	-						
1524	1.1	13720	3810	3	2	-						
1733	0.98	13720	3810	2	3	-						
1737	0.98	13720	3810	3	2	-						
1930	0.88	13720	3810	2	3	-						
1961	0.87	13720	3810	3	3	-						
2129	0.80	13720	3810	2	3	-						
2209	0.77	13720	3810	3	3	-						
2518	0.68	13720	3810	3	3	-						
2595	0.66	13720	3810	2	3	-						
2770	0.61	13720	3810	2	3	-						
2873	0.59	13720	3810	3	3	-						
3182	0.53	13720	3810	2	3	-						
3233	0.53	13720	3810	3	3	-						
3703	0.46	13720	3810	2	3	-						
3744	0.45	13720	3810	3	3	-						
4020	0.42	13720	3810	2	3	-						

R87R57, n_e = 1700 rpm 13720 lb-in

i [ratio]	n _a [rpm]	T _{a max} [lb-in]	F _{Ra} ¹⁾ [lb]	Stages		φ (/R) [']	AM					
				Lg	Sm		56	143	145	182	184	213/215
4206	0.40	13720	3810	3	3	-						
4831	0.35	13720	3810	3	3	-						
5449	0.31	13720	3810	3	3	-						
6174	0.28	13720	3810	3	3	-						
7038	0.24	13720	3810	3	3	-						
8109	0.21	13720	3810	3	3	-						
9244	0.18	13720	3810	3	3	-						
10549	0.16	13720	3810	3	3	-						
12025	0.14	13720	3810	3	3	-						
13813	0.12	13720	3810	3	3	-						
15310	0.11	13720	3810	3	3	-						
17452	0.10	13720	3810	3	3	-						

Weight [lbs]		Stages		AM						
		Large	Small	56	143	145	182	184	213/215	
R87R57	NEMA	2	2	185	185	190	195	195	210	
		2	3	185	190	190	200	200	210	
		3	2	185	190	190	200	200	210	
		3	3	190	195	195	200	200	215	
					71	80	90	100	112	132S/M
	IEC	2	2	185	185	190	200	200	215	
		2	3	185	190	190	200	200	215	
		3	2	185	190	190	200	200	215	
		3	3	190	195	195	205	205	220	

RF87: + 16 lbs / RM87: + 81 lbs

8.1.19 R97

R97, n _e = 1700 rpm						26500 lb-in						
Stages	i [ratio]	n _a [rpm]	T _{a max} [lb-in]	F _{Ra} [lb]	Φ (°/R) [']	AM						
						182	184	213/215	254/256	284/286	324/326	364/365
R97  2	4.50	378	14400	1960	6							
	5.20	327	15700	2030	6							
	6.21	274	16700	2160	6							
	7.12	239	17600	2250	6							
	8.39	203	17900	2410	6							
	9.29	183	17900	2520	6							
	10.83	157	18400	2490	6							
	12.39	137	19300	2610	6							
	14.62	116	20300	2760	6							
	16.17	105	21200	2850	6							
	18.24	93	22100	2960	6							
	20.14	84	23000	3050	5							
	22.37	76	24000	3150	5							
	25.03	68	25000	3270	5							
27.19	63	22600	1340	5								
32.05	53	22600	1800	5								
27.58	62	23600	3490	6								
33.25	51	25500	3690	6								
37.13	46	26500	3830	6								
42.78	40	26500	4080	6								
47.58	36	26500	4280	6								
53.21	32	26500	4450	6								
59.92	28	26500	4450	6								
65.21	26	26500	4450	6								
72.17	24	26500	3300	6								
83.15	20	26500	3840	6								
92.48	18	26500	4270	6								
103.44	16	26500	4450	6								
116.48	15	26500	4450	6								
126.75	13	26500	4450	6								
150.78	11	26500	4450	6								
170.02	10.0	26500	4450	6								
186.30	9.1	26500	4450	6								
216.28	7.9	26500	4450	6								
241.25	7.0	26500	4450	6								
255.71	6.6	26500	4450	6								
289.74	5.9	26500	4450	6								

Weight [lbs]		Stages	AM						
			182	184	213/215	254/256	284/286	324/326	364/365
R97	NEMA	2	235	235	245	280	280	320	320
		3	240	240	250	285	290	325	325
			100	112	132S/M	160	180	200	225
	IEC	2	235	235	250	290	290	325	335
3		240	240	255	295	295	330	340	

RF97: + 38 lbs / RM97: +150 lbs

8.1.20 R97R57

R97R57, n _e = 1700 rpm							26500 lb-in					
i [ratio]	n _a [rpm]	T _{a max} [lb-in]	F _{Ra} ¹⁾ [lb]	Stages		φ (/R) [']	AM					
				Lg	Sm		56	143	145	182	184	213/215
209	8.1	26500	4450	3	2	-						
227	7.5	26500	4450	2	2	-						
234	7.3	26500	4450	3	2	-						
249	6.8	26500	4450	3	2	-						
270	6.3	26500	4450	2	2	-						
296	5.7	26500	4450	3	2	-						
297	5.7	26500	4450	2	2	-						
336	5.1	26500	4450	3	2	-						
349	4.9	26500	4450	2	2	-						
370	4.6	26500	4450	2	2	-						
379	4.5	26500	4450	3	2	-						
420	4.0	26500	4450	2	2	-						
431	3.9	26500	4450	3	2	-						
466	3.6	26500	4450	2	2	-						
484	3.5	26500	4450	3	2	-						
549	3.1	26500	4450	2	2	-						
560	3.0	26500	4450	3	2	-						
625	2.7	26500	4450	2	2	-						
632	2.7	26500	4450	3	2	-						
737	2.3	26500	4450	3	2	-						
755	2.3	26500	4450	2	3	-						
824	2.1	26500	4450	3	2	-						
878	1.9	26500	4450	2	3	-						
934	1.8	26500	4450	2	3	-						
938	1.8	26500	4450	3	2	-						
1069	1.6	26500	4450	3	2	-						
1084	1.6	26500	4450	2	3	-						
1207	1.4	26500	4450	2	3	-						
1228	1.4	26500	4450	3	2	-						
1396	1.2	26500	4450	3	2	-						
1434	1.2	26500	4450	2	3	-						
1583	1.1	26500	4450	3	2	-						
1623	1.0	26500	4450	2	3	-						
1733	0.98	26500	4450	2	3	-						
1823	0.93	26500	4450	3	2	-						
2016	0.84	26500	4450	2	3	-						
2078	0.82	26500	4450	3	2	-						
2245	0.76	26500	4450	2	3	-						
2311	0.74	26500	4450	3	2	-						
2668	0.64	26500	4450	2	3	-						
2722	0.62	26500	4450	3	2	-						
3019	0.56	26500	4450	2	3	-						
3065	0.55	26500	4450	3	2	-						
3481	0.49	26500	4450	3	3	-						
3702	0.46	26500	4450	2	3	-						
4004	0.42	26500	4450	3	3	-						
4309	0.39	26500	4450	2	3	-						
4559	0.37	26500	4450	3	3	-						
4678	0.36	26500	4450	2	3	-						
5161	0.33	26500	4450	3	3	-						
5931	0.29	26500	4450	3	3	-						



R97R57, $n_e = 1700$ rpm 26500 lb-in

i [ratio]	n_a [rpm]	T_a max [lb-in]	$F_{Ra}^{1)}$ [lb]	Stages		ϕ (/R) [']	AM					
				Lg	Sm		56	143	145	182	184	213/215
6708	0.25	26500	4450	3	3	-						
7692	0.22	26500	4450	3	3	-						
8706	0.20	26500	4450	3	3	-						
10030	0.17	26500	4450	3	3	-						
11156	0.15	26500	4450	3	3	-						
13320	0.13	26500	4450	3	3	-						
14999	0.11	26500	4450	3	3	-						
17230	0.10	26500	4450	3	3	-						
19332	0.09	26500	4450	3	3	-						
21769	0.08	26500	4450	3	3	-						

Weight [lbs]		Stages		AM						
		Large	Small	56	143	145	182	184	213/215	
R97R57	NEMA	2	2	275	275	275	285	285	300	
		2	3	275	280	280	285	285	300	
		3	2	280	285	285	290	290	305	
		3	3	280	285	285	295	295	305	
					71	80	90	100	112	132S/M
	IEC	2	2	270	275	275	285	285	305	
		2	3	275	280	280	290	290	305	
		3	2	280	285	285	295	295	310	
		3	3	280	285	285	295	295	310	

RF97: + 38 lbs / RM97: + 150 lbs

8.1.21 R107

R107, n _e = 1700 rpm						38100 lb-in						
Stages	i [ratio]	n _a [rpm]	T _{a max} [lb-in]	F _{Ra} [lb]	φ (/R) [']	AM						
						182	184	213/215	254/256	284/286	324/326	364/365
R107  2	4.92	346	25600	2320	9							
	5.82	292	26200	2480	9							
	6.66	255	26200	2640	9							
	7.86	216	26200	2840	9							
	8.56	199	38100	2280	7							
	10.13	168	38100	2500	7							
	11.59	147	38100	2690	7							
	13.66	124	38100	2930	7							
	15.65	109	38100	3140	7							
	18.21	93	38100	3390	7							
	20.07	85	38100	3550	7							
	22.62	75	38100	3760	7							
	24.90	68	38100	3940	7							
	27.58	62	38100	4130	7							
30.77	55	38100	4340	7								
R107  3	29.49	58	38100	4260	7							
	35.26	48	38100	4620	7							
	40.37	42	38100	4910	7							
	47.63	36	38100	5280	7							
	52.68	32	38100	5510	7							
	59.41	29	38100	5800	7							
	65.60	26	38100	6050	7							
	72.88	23	38100	6320	7							
	78.57	22	38100	6520	7							
	92.70	18	38100	6620	7							
	102.53	17	38100	6620	7							
	115.63	15	38100	6620	7							
	127.68	13	38100	6620	7							
	141.83	12	38100	6620	7							
	158.68	11	38100	6620	7							
	172.34	9.9	38100	6620	7							
203.16	8.4	38100	6620	7								
229.95	7.4	38100	6620	7								
251.15	6.8	38100	6620	7								

8

Weight [lbs]		Stages	AM						
			182	184	213/215	254/256	284/286	324/326	364/365
R107	NEMA	2	355	355	360	395	400	435	435
		3	370	370	370	410	415	450	450
			100	112	132S/M	160	180	200	225
	IEC	2	355	355	360	405	405	440	450
		3	370	370	375	420	420	455	465
	RF107: + 13 lbs / RM107: +205 lbs								

8.1.22 R107R77

R107R77, n_e = 1700 rpm							38100 lb-in					
i	n_a	T_{a max}	F_{Ra}¹⁾	Stages		φ (/R)	AM					
				Lg	Sm		56	143	145	182	184	213/215
172	9.9	38100	6620	2	2	-						
187	9.1	38100	6620	3	2	-						
193	8.8	38100	6620	2	2	-						
214	7.9	38100	6620	3	2	-						
220	7.7	38100	6620	2	2	-						
253	6.7	38100	6620	3	2	-						
256	6.6	38100	6620	2	2	-						
284	6.0	38100	6620	2	2	-						
285	6.0	38100	6620	3	2	-						
323	5.3	38100	6620	3	2	-						
325	5.2	38100	6620	2	2	-						
369	4.6	38100	6620	3	2	-						
377	4.5	38100	6620	2	2	-						
417	4.1	38100	6620	3	2	-						
426	4.0	38100	6620	2	2	-						
469	3.6	38100	6620	2	2	-						
492	3.5	38100	6620	3	2	-						
528	3.2	38100	6620	2	3	-						
544	3.1	38100	6620	3	2	-						
614	2.8	38100	6620	3	2	-						
626	2.7	38100	6620	2	3	-						
717	2.4	38100	6620	2	3	-						
815	2.1	38100	6620	2	3	-						
822	2.1	38100	6620	3	2	-						
919	1.8	38100	6620	2	3	-						
939	1.8	38100	6620	3	2	-						
1055	1.6	38100	6620	2	3	-						
1104	1.5	38100	6620	3	2	-						
1209	1.4	38100	6620	2	3	-						
1226	1.4	38100	6620	3	2	-						
1400	1.2	38100	6620	3	2	-						
1407	1.2	38100	6620	2	3	-						
1550	1.1	38100	6620	2	3	-						
1599	1.1	38100	6620	3	2	-						
1693	1.0	38100	6620	2	3	-						
1827	0.93	38100	6620	3	2	-						
1987	0.86	38100	6620	3	2	-						
2067	0.82	38100	6620	2	3	-						
2280	0.75	38100	6620	2	3	-						
2339	0.73	38100	6620	3	3	-						
2653	0.64	38100	6620	2	3	-						
2688	0.63	38100	6620	3	3	-						
3034	0.56	38100	6620	2	3	-						
3039	0.56	38100	6620	3	3	-						
3343	0.51	38100	6620	2	3	-						
3432	0.50	38100	6620	3	3	-						
3896	0.44	38100	6620	3	3	-						
3918	0.43	38100	6620	2	3	-						
4435	0.38	38100	6620	3	3	-						
5168	0.33	38100	6620	3	3	-						
5914	0.29	38100	6620	3	3	-						



R107R77, $n_e = 1700$ rpm 38100 lb-in

i [ratio]	n_a [rpm]	T_a max [lb-in]	$F_{Ra}^{1)}$ [lb]	Stages		ϕ (/R) [']	AM					
				Lg	Sm		56	143	145	182	184	213/215
6743	0.25	38100	6620	3	3	-						
7583	0.22	38100	6620	3	3	-						
8618	0.20	38100	6620	3	3	-						
9547	0.18	38100	6620	3	3	-						
11256	0.15	38100	6620	3	3	-						
12829	0.13	38100	6620	3	3	-						
14936	0.11	38100	6620	3	3	-						
17080	0.10	38100	6620	3	3	-						
20018	0.08	38100	6620	3	3	-						

Weight [lbs]		Stages		AM						
		Large	Small	56	143	145	182	184	213/215	
R107R77	NEMA	2	2	425	430	430	435	435	450	
		2	3	425	430	430	440	440	450	
		3	2	440	445	445	450	450	465	
		3	3	440	445	445	455	455	465	
					71	80	90	100	112	132S/M
	IEC	2	2	425	430	430	440	440	455	
		2	3	425	430	430	440	440	455	
		3	2	440	445	445	455	455	470	
		3	3	440	445	445	455	455	470	

RF107: + 13 lbs / RM107: + 205 lbs

8.1.23 R137

R137, n_e = 1700 rpm						70700 lb-in				
Stages	i [ratio]	n _a [rpm]	T _{a max} [lb-in]	F _{Ra} [lb]	Φ (°/R) [']	AM				
						213/215	254/256	284/286	324/326	364/365
R137  2	5.15	330	40700	7070	8					
	6.38	266	45200	7340	8					
	7.59	224	45200	8000	8					
	8.71	195	69300	5410	6					
	10.79	158	70700	6130	6					
	12.83	133	70700	6890	6					
	14.51	117	70700	7450	6					
	16.80	101	70700	8150	6					
	19.04	89	70700	8770	6					
	22.00	77	70700	9520	6					
	24.12	70	70700	10000	6					
	29.57	57	68800	11400	6					
R137  3	27.83	61	67900	11100	6					
	32.91	52	70700	11800	6					
	37.65	45	70700	12000	6					
	44.39	38	70700	12000	6					
	50.86	33	70700	12000	6					
	59.17	29	70700	12000	6					
	65.20	26	70700	12000	6					
	73.49	23	70700	12000	6					
	80.91	21	70700	12000	6					
	88.70	19	70700	12000	6					
	103.20	16	70700	12000	6					
	113.72	15	70700	12000	6					
	128.18	13	70700	12000	6					
	141.12	12	70700	12000	6					
	156.31	11	70700	12000	6					
	174.40	9.7	70700	12000	6					
	188.45	9.0	70700	12000	6					
	222.60	7.6	70700	12000	6					

Weight [lbs]		Stages	213/215	254/256	AM		
R137	NEMA				284/286	324/326	364/365
			2	540	570	580	610
		3	560	590	600	640	640
			132S/M	160	180	200	225
	IEC	2	540	580	580	620	630
		3	570	600	600	640	650

RF137: + 51 lbs / RM137: +296 lbs

8.1.24 R137R77

R137R77, n _e = 1700 rpm							70700 lb-in					
i [ratio]	n _a [rpm]	T _{a max} [lb-in]	F _{Ra} ¹⁾ [lb]	Stages		φ (/R) [']	AM					
				Lg	Sm		56	143	145	182	184	213/215
175	9.7	70700	12000	3	2	-						
197	8.6	70700	12000	3	2	-						
223	7.6	70700	12000	3	2	-						
255	6.7	70700	12000	3	2	-						
291	5.8	70700	12000	3	2	-						
297	5.7	70700	12000	2	2	-						
323	5.3	70700	12000	3	2	-						
339	5.0	70700	12000	2	2	-						
376	4.5	70700	12000	2	2	-						
381	4.5	70700	12000	3	2	-						
428	4.0	70700	12000	3	2	-						
453	3.8	70700	12000	2	2	-						
490	3.5	70700	12000	3	2	-						
517	3.3	70700	12000	2	2	-						
560	3.0	70700	12000	3	2	-						
564	3.0	70700	12000	2	2	-						
609	2.8	70700	12000	2	3	-						
629	2.7	70700	12000	3	2	-						
699	2.4	70700	12000	2	3	-						
730	2.3	70700	12000	3	2	-						
831	2.0	70700	12000	3	2	-						
888	1.9	70700	12000	2	3	-						
951	1.8	70700	12000	3	2	-						
1043	1.6	70700	12000	2	3	-						
1090	1.6	70700	12000	3	2	-						
1105	1.5	70700	12000	2	3	-						
1226	1.4	70700	12000	3	2	-						
1256	1.4	70700	12000	2	3	-						
1391	1.2	70700	12000	2	3	-						
1397	1.2	70700	12000	3	2	-						
1586	1.1	70700	12000	2	3	-						
1598	1.1	70700	12000	3	2	-						
1839	0.92	70700	12000	3	2	-						
1863	0.91	70700	12000	2	3	-						
2073	0.82	70700	12000	3	2	-						
2242	0.76	70700	12000	2	3	-						
2412	0.70	70700	12000	3	2	-						
2484	0.68	70700	12000	2	3	-						
2658	0.64	70700	12000	3	2	-						
2929	0.58	70700	12000	2	3	-						
2993	0.57	70700	12000	3	3	-						
3338	0.51	70700	12000	2	3	-						
3454	0.49	70700	12000	3	3	-						
3514	0.48	70700	12000	2	3	-						
3928	0.43	70700	12000	3	3	-						
4018	0.42	70700	12000	2	3	-						
4464	0.38	70700	12000	3	3	-						
4709	0.36	70700	12000	2	3	-						
5116	0.33	70700	12000	3	3	-						
5834	0.29	70700	12000	3	3	-						
6559	0.26	70700	12000	3	3	-						



R137R77, n_e = 1700 rpm 70700 lb-in

i [ratio]	n _a [rpm]	T _{a max} [lb-in]	F _{Ra} ¹⁾ [lb]	Stages		φ (/R) [']	AM					
				Lg	Sm		56	143	145	182	184	213/215
7479	0.23	70700	12000	3	3	-						
8784	0.19	70700	12000	3	3	-						
10573	0.16	70700	12000	3	3	-						
11712	0.15	70700	12000	3	3	-						
12921	0.13	70700	12000	3	3	-						
14777	0.12	70700	12000	3	3	-						
16566	0.10	70700	12000	3	3	-						
18945	0.09	70700	12000	3	3	-						
22203	0.08	70700	12000	3	3	-						

Weight [lbs]		Stages		AM						
		Large	Small	56	143	145	182	184	213/215	
R137R77	NEMA	2	2	610	610	610	620	620	630	
		2	3	610	610	610	620	620	630	
		3	2	630	630	630	640	640	650	
		3	3	630	640	640	640	640	660	
					71	80	90	100	112	132S/M
	IEC	2	2	610	610	610	620	620	640	
		2	3	610	610	610	620	620	640	
		3	2	630	630	630	640	640	660	
		3	3	630	640	640	650	650	660	

RF137: + 51 lbs / RM137: + 296 lbs

8.1.25 R147

R147, $n_e = 1700$ rpm						115000 lb-in			
Stages	i [ratio]	n_a [rpm]	$T_{a \max}$ [lb-in]	F_{Ra} [lb]	Φ (/R) [']	AM			
						254/256	284/286	324/326	364/365
R147  2	5.00	340	76700	10100	8				
	5.89	289	76700	10900	8				
	7.25	234	76700	12000	8				
	8.26	206	115000	10100	6				
	9.74	175	115000	11000	6				
	11.99	142	115000	12300	5				
	13.91	122	111400	13500	5				
	15.64	109	115000	14100	5				
	18.04	94	92900	15100	5				
R147  3	24.19	70	105200	14500	6				
	29.95	57	115000	14100	6				
	35.64	48	115000	14100	6				
	40.29	42	115000	14100	6				
	46.65	36	115000	14100	6				
	52.87	32	115000	14100	6				
	61.09	28	115000	14100	6				
	66.99	25	115000	14100	6				
	72.09	24	115000	14100	6				
	83.47	20	115000	14100	6				
	94.60	18	115000	14100	6				
	109.31	16	115000	14100	5				
	119.86	14	115000	14100	5				
	146.91	12	115000	14100	5				
163.31	10	115000	14100	5					

8

Weight [lbs]		Stages	AM			
			254/256	284/286	324/326	364/365
R147	NEMA	2	850	860	890	890
		3	880	890	920	920
			160	180	200	225
	IEC	2	860	860	890	910
		3	890	890	920	930

RF147: +18 lbs / RM147: +387 lbs

8.1.26 R147R77

R147R77, n_e = 1700 rpm							115000 lb-in					
i [ratio]	n _a [rpm]	T _{a max} [lb-in]	F _{Ra} ¹⁾ [lb]	Stages		φ (/R) [']	AM					
				Lg	Sm		56	143	145	182	184	213/215
415	4.1	115000	14100	3	2	-						
489	3.5	115000	14100	3	2	-						
558	3.0	115000	14100	3	2	-						
619	2.7	115000	14100	3	2	-						
695	2.4	115000	14100	3	2	-						
784	2.2	115000	14100	3	2	-						
889	1.9	115000	14100	3	2	-						
1029	1.7	115000	14100	3	2	-						
1166	1.5	115000	14100	3	2	-						
1329	1.3	115000	14100	3	2	-						
1536	1.1	115000	14100	3	2	-						
1705	1.0	115000	14100	3	2	-						
1951	0.87	115000	14100	3	2	-						
2211	0.77	115000	14100	3	2	-						
2555	0.67	115000	14100	3	2	-						
2898	0.59	115000	14100	3	3	-						
3302	0.51	115000	14100	3	3	-						
3754	0.45	115000	14100	3	3	-						
4325	0.39	115000	14100	3	3	-						
4926	0.35	115000	14100	3	3	-						
5568	0.31	115000	14100	3	3	-						
6447	0.26	115000	14100	3	3	-						
7307	0.23	115000	14100	3	3	-						
8443	0.20	115000	14100	3	3	-						
9743	0.17	115000	14100	3	3	-						
11143	0.15	115000	14100	3	3	-						
12344	0.14	115000	14100	3	3	-						
14075	0.12	115000	14100	3	3	-						
15923	0.11	115000	14100	3	3	-						
18210	0.09	115000	14100	3	3	-						
21342	0.08	115000	14100	3	3	-						
23401	0.07	115000	14100	3	3	-						

Weight [lbs]		Stages		AM					
		Large	Small	56	143	145	182	184	213/215
R147R77	NEMA	3	2	920	920	920	930	930	950
		3	3	920	930	930	940	940	950
	IEC			71	80	90	100	112	132S/M
		3	2	920	920	920	930	930	950
		3	3	920	930	930	940	940	950

RF147: +18 lbs / RM147: +387 lbs



8.1.27 R147R87

R147R87, $n_e = 1700$ rpm							115000 lb-in						
i [ratio]	n_a [rpm]	$T_{a \max}$ [lb-in]	$F_{Ra}^{1)}$ [lb]	Stages		ϕ (/R) [']	AM						
				Lg	Sm		143	145	182	184	213/215	254/256	284/286
159	11	115000	14100	3	2	-							
189	9.0	115000	14100	3	2	-							
214	7.9	115000	14100	3	2	-							
247	6.9	115000	14100	3	2	-							
280	6.1	115000	14100	3	2	-							
326	5.2	115000	14100	3	2	-							
368	4.6	115000	14100	3	2	-							
426	4.0	115000	14100	3	2	-							
462	3.7	115000	14100	3	2	-							
533	3.2	115000	14100	3	2	-							

Weight [lbs]		Stages		AM						
		Large	Small	143	145	182	184	213/215	254/256	284/286
R147R87	NEMA	3	2	970	970	980	980	990	1020	1030
				80	90	100	112	132S/M	160	180
	IEC	3	2	970	970	980	980	1000	1030	1030

RF147: + 18 lbs / RM147: + 387 lbs

8.1.28 R167

R167, n_e = 1700 rpm						159200 lb-in			
Stages	i [ratio]	n _a [rpm]	T _{a max} [lb-in]	F _{Ra} [lb]	Φ (/R) [']	AM			
						254/256	284/286	324/326	364/365
R167  2	10.24	166	150400	16900	5				
	11.99	142	150400	18200	5				
	14.48	117	159200	19300	5				
	16.98	100	132700	22600	5				
	19.03	89	141500	23100	5				
	21.85	78	115000	26300	5				
	24.57	69	123800	26900	5				
	30.71	55	88400	27000	5				
	37.74	45	79600	27000	5				
	46.00	37	61900	27000	5				
R167  3	23.71	72	159200	24100	6				
	27.96	61	159200	25900	6				
	34.41	49	159200	27000	6				
	39.92	43	159200	27000	6				
	44.87	38	159200	27000	6				
	51.76	33	159200	27000	6				
	58.65	29	159200	27000	6				
	67.40	25	159200	27000	6				
	73.70	23	159200	27000	6				
	82.91	21	159200	27000	5				
	93.19	18	159200	27000	5				
	107.49	16	159200	27000	5				
	121.81	14	159200	27000	5				
	139.98	12	159200	27000	5				
	153.07	11	159200	27000	5				
186.93	9.1	159200	27000	5					
229.71	7.4	159200	27000	5					

Weight [lbs]		Stages	AM			
			254/256	284/286	324/326	364/365
R167	NEMA	2	1420	1420	1470	1470
		3	1430	1430	1480	1480
			160	180	200	225
	IEC	2	1430	1430	1470	1480
		3	1440	1440	1480	1490

RF167: +14 lbs / RM167: +444 lbs

8.1.29 R167R97

R167R97, n _e = 1700 rpm							159200 lb-in					
i [ratio]	n _a [rpm]	T _{a max} [lb-in]	F _{Ra} ¹⁾ [lb]	Stages		Φ (/R) [']	AM					
				Lg	Sm		182	184	213/215	254/256	284/286	324/326
279	6.1	159200	27000	3	2	-						
303	5.6	159200	27000	3	2	-						
335	5.1	159200	27000	3	2	-						
376	4.5	159200	27000	3	2	-						
432	3.9	159200	27000	3	2	-						
503	3.4	159200	27000	3	2	-						
579	2.9	159200	27000	3	2	-						
656	2.6	159200	27000	3	2	-						
760	2.2	159200	27000	3	2	-						
861	2.0	159200	27000	3	2	-						
999	1.7	159200	27000	3	2	-						
1123	1.5	159200	27000	3	2	-						
1279	1.3	159200	27000	3	2	-						
1438	1.2	159200	27000	3	2	-						
1670	1.0	159200	27000	3	2	-						
1877	0.91	159200	27000	3	2	-						
2085	0.82	159200	27000	3	2	-						
2333	0.73	159200	27000	3	2	-						
2657	0.64	159200	27000	3	2	-						
3099	0.55	159200	27000	3	3	-						
3692	0.46	159200	27000	3	3	-						
4129	0.41	159200	27000	3	3	-						
4650	0.37	159200	27000	3	3	-						
5407	0.31	159200	27000	3	3	-						
6077	0.28	159200	27000	3	3	-						
6894	0.25	159200	27000	3	3	-						
7749	0.22	159200	27000	3	3	-						
10509	0.16	159200	27000	3	3	-						
11812	0.14	159200	27000	3	3	-						
14051	0.12	159200	27000	3	3	-						
15446	0.11	159200	27000	3	3	-						
17361	0.10	159200	27000	3	3	-						

8

Weight [lbs]		Stages		AM							
		Large	Small	182	184	213/215	254/256	284/286	324/326	364/365	
R167R97	NEMA	3	2	1660	1660	1670	1700	1710	1740	1740	
		3	3	1660	1660	1680	1710	1710	1750	1750	
					100	112	132S/M	160	180	200	225
	IEC	3	2	1660	1660	1670	1710	1710	1750	1760	
		3	3	1670	1670	1680	1720	1720	1760	1770	
	RF167: + 14 lbs / RM167: + 444 lbs										

8.1.30 R167R107

R167R107, n_e = 1700 rpm							159200 lb-in						
i [ratio]	n _a [rpm]	T _{a max} [lb-in]	F _{Ra} ¹⁾ [lb]	Stages		φ (/R) [']	AM						
				Lg	Sm		182	184	213/215	254/256	284/286	324/326	364/365
168	10	159200	27000	2	2	-							
169	10	159200	27000	3	2	-							
198	8.6	159200	27000	2	2	-							
200	8.5	159200	27000	3	2	-							
227	7.5	159200	27000	2	2	-							
229	7.4	159200	27000	3	2	-							
264	6.4	159200	27000	2	2	-							
270	6.3	159200	27000	3	2	-							
291	5.8	159200	27000	2	2	-							
295	5.8	159200	27000	3	2	-							
328	5.2	159200	27000	2	2	-							
349	4.9	159200	27000	3	2	-							
361	4.7	159200	27000	2	2	-							
399	4.3	159200	27000	2	2	-							
446	3.8	159200	27000	2	2	-							
511	3.3	159200	27000	2	3	-							
585	2.9	159200	27000	2	3	-							
690	2.5	159200	27000	2	3	-							
763	2.2	159200	27000	2	3	-							
860	2.0	159200	27000	2	3	-							
950	1.8	159200	27000	2	3	-							
1111	1.5	159200	27000	2	3	-							
1229	1.4	159200	27000	2	3	-							
1342	1.3	159200	27000	2	3	-							
1485	1.1	159200	27000	2	3	-							
1674	1.0	159200	27000	2	3	-							
1849	0.92	159200	27000	2	3	-							
2066	0.82	159200	27000	2	3	-							
2298	0.74	159200	27000	2	3	-							
2436	0.70	159200	27000	2	3	-							
2757	0.62	159200	27000	2	3	-							
3330	0.51	159200	27000	2	3	-							
3637	0.47	159200	27000	2	3	-							

Weight [lbs]		Stages		AM						
		Large	Small	182	184	213/215	254/256	284/286	324/326	364/365
R167R107	NEMA	2	2	1750	1750	1750	1790	1790	1830	1830
		2	3	1760	1760	1770	1800	1810	1850	1850
		3	2	1760	1760	1770	1800	1810	1850	1850
	IEC			100	112	132S/M	160	180	200	225
		2	2	1750	1750	1760	1800	1800	1840	1850
		2	3	1760	1760	1770	1810	1810	1850	1860
		3	2	1760	1760	1770	1810	1810	1850	1860

RF167: + 14 lbs / RM167: + 444 lbs

8.2 R / RX.. AD

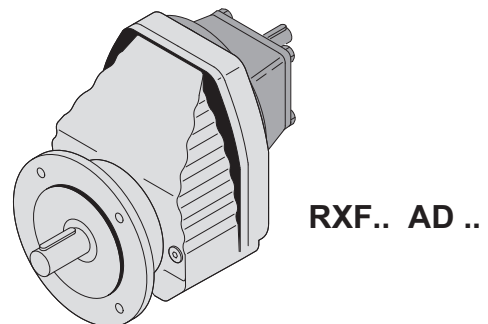
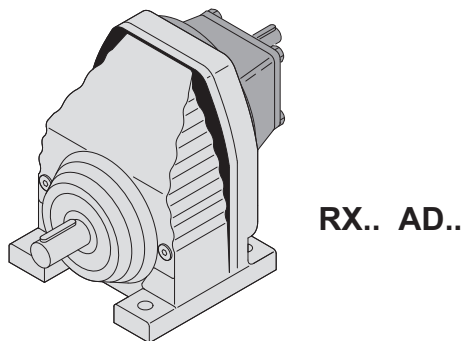
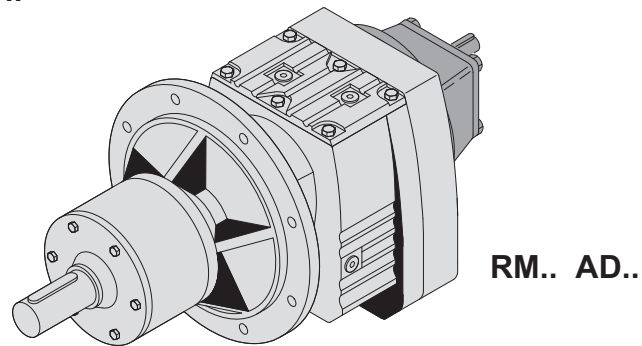
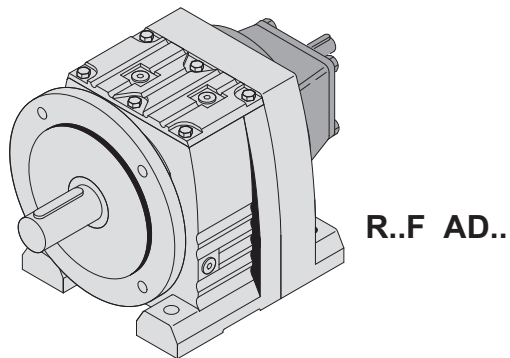
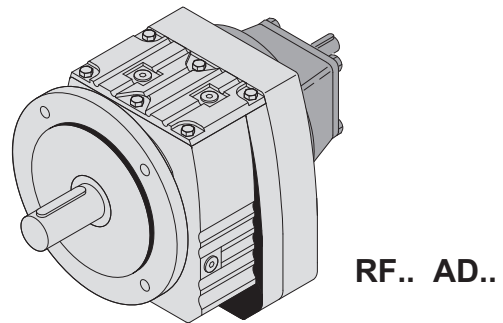
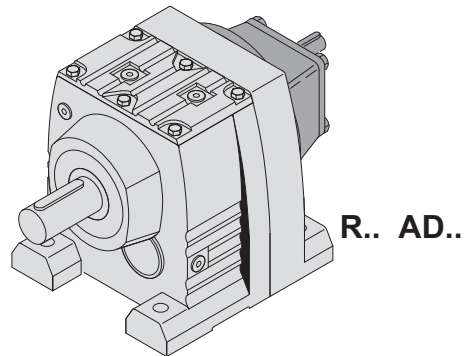



8

R_AD

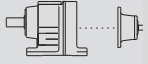
8.2.1 RX57 - RX107

i [ratio]	n _a [rpm]	Ma _{max} [lb-in]	P _e [HP]	F _{Ra} ¹⁾ [lb]	F _{Re} [lb]	Stages		φ (/R) [']			
						Lg	Sm				
RX57 AD.. , n_e = 1700 rpm											610 lb-in
2.64	644	610	6.3	330	170	1	-	-	-		
2.91	584	430	4.0	490	240	1	-	-	-		
3.14	541	580	5.1	480	190	1	-	-	-		
3.55	479	490	3.8	520	230	1	-	-	-		
3.79	449	510	3.7	530	230	1	-	-	-		RX57
4.35	391	540	3.4	560	220	1	-	-	-		AD2
5.07	335	300	1.6	640	110	1	-	-	-		
5.50	309	330	1.6	650	80	1	-	-	-		
1.30	1308	560	11.8	0	340	1	-	-	M2		
1.48	1149	600	11.1	0	330	1	-	-	-		
1.65	1030	610	10.1	30	340	1	-	-	-		
1.92	885	610	8.7	130	360	1	-	-	-		
2.04	833	610	8.2	170	370	1	-	-	-		
2.37	717	610	7.0	260	380	1	-	-	-		
2.64	644	610	6.3	330	390	1	-	-	-		
3.14	541	580	5.1	480	410	1	-	-	-		
RX67 AD.. , n_e = 1700 rpm											1090 lb-in
3.77	451	770	5.6	640	170	1	-	-	-		
4.30	395	610	3.9	700	230	1	-	-	-		
4.53	375	630	3.8	710	220	1	-	-	-		
5.18	328	660	3.5	750	220	1	-	-	-		
6.07	280	360	1.6	840	110	1	-	-	-		
1.40	1214	800	15.6	140	280	1	-	-	M1-6		
1.61	1056	880	15.0	150	270	1	-	-	M2		
1.86	914	960	14.1	170	240	1	-	-	M2		
2.04	833	1010	13.6	180	230	1	-	-	-		
2.40	708	1090	12.4	240	220	1	-	-	-		
2.54	669	1040	11.2	340	270	1	-	-	-		
2.89	588	930	8.8	550	320	1	-	-	-		
3.20	531	890	7.6	580	340	1	-	-	-		
3.77	451	770	5.6	640	390	1	-	-	-		
RX77 AD.. , n_e = 1700 rpm											1900 lb-in
5.35	318	890	4.6	1100	200	1	-	-	-		
5.63	302	950	4.6	1110	190	1	-	-	-		
6.41	265	890	3.8	1180	210	1	-	-	-		
7.47	228	440	1.6	1310	110	1	-	-	-		
8.00	213	480	1.6	1330	80	1	-	-	-		
3.70	459	1270	9.4	910	310	1	-	-	-		
4.04	421	1270	8.6	940	310	1	-	-	-		
4.73	359	1090	6.3	1020	360	1	-	-	-		
1.42	1197	1370	26	0	580	1	-	-	M1-6		
1.67	1018	1530	25	0	560	1	-	-	M1-6		
1.88	904	1650	24	0	550	1	-	-	M1-6		
2.13	798	1770	23	0	540	1	-	-	M1-6		
2.43	700	1900	21	0	530	1	-	-	M2		
2.70	630	1900	19.3	120	560	1	-	-	-		
3.08	552	1710	15.2	440	620	1	-	-	-		
3.25	523	1610	13.6	580	640	1	-	-	-		
RX87 AD.. , n_e = 1700 rpm											3580 lb-in
7.20	236	1200	4.6	1550	210	1	-	-	-		
7.63	223	1280	4.6	1570	200	1	-	-	-		
8.65	197	1230	3.9	1650	210	1	-	-	-		
5.07	335	1900	10.3	1280	270	1	-	-	-		
5.56	306	1990	9.8	1320	250	1	-	-	-		
6.45	264	1700	7.2	1430	330	1	-	-	-		

i [ratio]	n _a [rpm]	Ma _{max} [lb-in]	P _e [HP]	F _{Ra} ¹⁾ [lb]	F _{Re} [lb]	Stages		φ (°/R) [']			
						Lg	Sm				
3.78	450	2700	19.6	1040	570	1	-	-	-		
4.50	378	2570	15.6	1140	610	1	-	-	-		RX87 AD4
1.39	1223	2570	51	0	1080	1	-	-	M1-6		
1.60	1063	2790	48	0	1070	1	-	-	M1-6		
1.93	881	3140	45	0	1050	1	-	-	M1-6		RX87 AD5
2.15	791	3410	43	0	1020	1	-	-	M1-6		
2.48	685	3580	40	0	1030	1	-	-	M1-6		
2.76	616	3580	36	90	1050	1	-	-	M1-6		
3.09	550	3580	32	250	1070	1	-	-	M1-6		RX87 AD5
3.48	489	3580	28	420	1090	1	-	-	-		
RX97 AD.. , n_e = 1700 rpm											5270 lb-in
6.56	259	2660	11.1	1770	210	1	-	-	-		
7.16	237	2300	8.8	1870	300	1	-	-	-		RX97 AD3
8.23	207	1990	6.6	2000	350	1	-	-	-		
4.91	346	3500	19.5	1500	570	1	-	-	-		RX97 AD4
5.79	294	3720	17.6	1590	550	1	-	-	-		
1.42	1197	3890	75	0	930	1	-	-	M1-6		
1.64	1037	4470	75	0	880	1	-	-	M1-6		
1.96	867	5040	70	0	810	1	-	-	M1-6		
2.24	759	5270	64	0	810	1	-	-	M1-6		
2.64	644	5270	55	230	900	1	-	-	M1-6		
2.92	582	5270	49	410	930	1	-	-	M1-6		
3.30	515	5270	44	600	950	1	-	-	M1-6		
3.64	467	5270	40	780	970	1	-	-	M2		
4.04	421	5270	36	960	990	1	-	-	-		
4.52	376	5270	32	1150	1010	1	-	-	-		
1.42	1197	4030	78	0	1530	1	-	-	M1-6		
1.64	1037	4470	75	0	1500	1	-	-	M1-6		
1.96	867	5040	70	0	1470	1	-	-	M1-6		
2.24	759	5270	64	0	1480	1	-	-	M1-6		
2.64	644	5270	55	230	1520	1	-	-	M1-6		
2.92	582	5270	49	410	1550	1	-	-	M1-6		
3.30	515	5270	44	600	1570	1	-	-	M2		
3.64	467	5270	40	780	1590	1	-	-	M2		
RX107 AD.. , n_e = 1700 rpm											7350 lb-in
5.61	303	4030	19.7	1890	530	1	-	-	-		
6.63	256	4070	16.8	2020	540	1	-	-	-		RX107 AD4
3.38	503	7350	60	740	560	1	-	-	M1-6		
3.81	446	7350	53	970	610	1	-	-	M2		
4.20	405	7350	48	1150	660	1	-	-	-		RX107 AD5
4.65	366	6150	36	1530	940	1	-	-	-		
5.19	328	6150	32	1620	950	1	-	-	-		
1.44	1181	4780	91	380	1440	1	-	-	M1-6		
1.71	994	5660	91	200	1360	1	-	-	M1-6		
1.95	872	6460	91	60	1290	1	-	-	M1-6		
2.30	739	7350	88	0	1160	1	-	-	M1-6		
2.64	644	7350	76	240	1260	1	-	-	M1-6		
3.07	554	7350	66	550	1330	1	-	-	M1-6		
3.38	503	7350	60	740	1350	1	-	-	M1-6		
3.81	446	7350	53	970	1380	1	-	-	M2		
4.20	405	7350	48	1150	1400	1	-	-	-		

Weight [lbs]						
Gear Unit	Stages	AD2	AD3	AD4	AD5	AD6
RX57	1	28	35			
RXF57	1	32	39			
RX67	1	24	41			

Weight [lbs]						
Gear Unit	Stages	AD2	AD3	AD4	AD5	AD6
RXF67	1	43	50			
RX77	1	55	63	76		
RXF77	1	60	68	81		
RX87	1	91	100	115	145	
RXF87	1	100	110	125	155	
RX97	1		155	165	200	230
RXF97	1		175	185	220	250
RX107	1			240	270	300
RXF107	1			280	310	340

8.2.2 R27

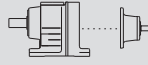
R27 AD.. , n _e = 1700 rpm										1150 lb-in		
i [ratio]	n _a [rpm]	T _a max [lb-in]	P _e [HP]	F _{RA} ¹⁾ [lb]	F _{Re} [lb]	Stages		φ ^(/R) [']			R27	AD1
						Lg	Sm					
24.47	69	1150	1.3	570	80	3	-	-	-			
26.09	65	770	0.82	640	60	2	-	-	-			
28.37	60	790	0.77	660	50	2	-	-	-			
28.78	59	1150	1.1	610	90	3	-	-	-			
32.47	52	1150	1.0	640	90	3	-	-	-			
36.79	46	1150	0.88	680	100	3	-	-	-			
39.25	43	1150	0.83	700	100	3	-	-	-			
44.90	38	1150	0.72	730	110	3	-	-	-			
48.17	35	1150	0.67	760	110	3	-	-	-			
55.87	30	1150	0.58	800	110	3	-	-	-			
61.30	28	1150	0.53	830	150	3	-	-	-			
69.47	24	1150	0.47	870	150	3	-	-	-			
74.11	23	1150	0.44	890	150	3	-	-	-			
84.78	20	1150	0.38	940	150	3	-	-	-			
90.96	19	1150	0.36	950	160	3	-	-	-			
105.49	16	1150	0.31	950	160	3	-	-	-			
123.91	14	1150	0.26	950	160	3	-	-	-			
135.09	13	1150	0.24	950	160	3	-	-	-			
3.37	504	700	5.8	150	240	2	-	-	M2			
4.00	425	750	5.2	150	240	2	-	-	-			
4.27	398	770	5.0	150	240	2	-	-	-			
5.00	340	840	4.7	140	240	2	-	-	-			
5.60	304	880	4.4	140	240	2	-	-	-			
6.59	258	940	4.0	140	240	2	-	-	-			
7.63	223	990	3.6	140	240	2	-	-	-			
8.16	208	1030	3.5	130	230	2	-	-	-			
9.41	181	1080	3.2	130	230	2	-	-	-			
10.13	168	1080	3.0	350	310	2	-	-	-			
11.86	143	1140	2.7	370	310	2	-	-	-			
13.28	128	1150	2.4	410	310	2	-	-	-			
15.63	109	1150	2.0	470	320	2	-	-	-			
18.08	94	1150	1.8	500	320	2	-	-	-			
19.35	88	1150	1.7	520	320	2	-	-	-			
22.32	76	1150	1.4	550	190	2	-	-	-			
24.47	69	1150	1.3	570	340	3	-	-	-			
26.09	65	1150	1.2	590	200	2	-	-	-			
28.37	60	1150	1.1	610	210	2	-	-	-			
28.78	59	1150	1.1	610	350	3	-	-	-			
32.47	52	1150	1.0	640	350	3	-	-	-			
36.79	46	1150	0.88	680	360	3	-	-	-			
39.25	43	1150	0.83	700	360	3	-	-	-			
44.90	38	1150	0.72	730	370	3	-	-	-			
48.17	35	1150	0.67	760	370	3	-	-	-			
55.87	30	1150	0.58	800	370	3	-	-	-			
61.30	28	1150	0.53	830	380	3	-	-	-			
69.47	24	1150	0.47	870	380	3	-	-	-			
74.11	23	1150	0.44	890	380	3	-	-	-			
84.78	20	1150	0.38	940	380	3	-	-	-			
90.96	19	1150	0.36	950	380	3	-	-	-			
105.49	16	1150	0.31	950	380	3	-	-	-			
123.91	14	1150	0.26	950	390	3	-	-	-			
135.09	13	1150	0.24	950	390	3	-	-	-			

8

Weight [lbs]	Stages		AD1	AD2
	Large	Small		
R27	2	-	13	15
	3	-	13	15
RF27: +0 lbs				

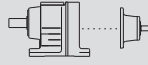

8.2.3 R37

R37 AD.. , n _e = 1700 rpm										1770 lb-in		
i [ratio]	n _a [rpm]	T _{a max} [lb-in]	P _e [HP]	F _{Ra} ¹⁾ [lb]	F _{Re} [lb]	Stages		φ _(/R) [']			R37	AD1
						Lg	Sm					
55.76	30	1770	0.90	1110	60	3	-	9	-			
61.18	28	1770	0.82	1110	120	3	-	8	-			
69.33	25	1770	0.72	1110	120	3	-	8	-			
73.96	23	1770	0.68	1110	120	3	-	8	-			
84.61	20	1770	0.59	1110	130	3	-	8	-			
90.77	19	1770	0.55	1110	130	3	-	8	-			
105.28	16	1770	0.47	1110	130	3	-	8	-			
123.66	14	1770	0.40	1110	140	3	-	8	-			
134.82	13	1770	0.37	1110	140	3	-	8	-			
3.41	499	950	7.7	180	190	2	-	14	M1-6			
4.05	420	1070	7.3	130	180	2	-	13	M1-6			
4.32	394	1120	7.2	110	180	2	-	13	M2			
5.06	336	1190	6.5	100	170	2	-	13	-			
5.67	300	1260	6.2	90	170	2	-	12	-			
6.67	255	1270	5.3	140	180	2	-	12	-			
7.97	213	1380	4.8	300	270	2	-	8	-			
9.47	180	1480	4.3	310	270	2	-	8	-			
10.11	168	1500	4.1	320	270	2	-	8	-			
11.83	144	1620	3.8	310	270	2	-	8	-			
13.25	128	1680	3.5	320	270	2	-	8	-			
15.60	109	1770	3.2	340	270	2	-	8	-			
18.05	94	1770	2.7	420	280	2	-	8	-			
19.31	88	1770	2.5	460	280	2	-	7	-			
22.27	76	1770	2.2	550	280	2	-	7	-			
24.42	70	1770	2.0	600	340	3	-	9	-			
26.03	65	1530	1.6	820	110	2	-	7	-		R37	AD2
28.32	60	1670	1.6	770	80	2	-	7	-			
28.73	59	1770	1.7	710	340	3	-	9	-			
32.40	52	1770	1.5	790	280	3	-	9	-			
36.72	46	1770	1.4	880	290	3	-	9	-			
39.17	43	1770	1.3	920	290	3	-	9	-			
44.81	38	1770	1.1	1020	300	3	-	9	-			
48.08	35	1770	1.0	1080	310	3	-	9	-			
55.76	30	1770	0.90	1110	310	3	-	9	-			
61.18	28	1770	0.82	1110	370	3	-	8	-			
69.33	25	1770	0.72	1110	370	3	-	8	-			
73.96	23	1770	0.68	1110	370	3	-	8	-			
84.61	20	1770	0.59	1110	380	3	-	8	-			
90.77	19	1770	0.55	1110	380	3	-	8	-			
105.28	16	1770	0.47	1110	380	3	-	8	-			
123.66	14	1770	0.40	1110	380	3	-	8	-			
134.82	13	1770	0.37	1110	380	3	-	8	-			

Weight [lbs]	Stages		AD1	AD2
	Large	Small		
R37	2	-	-	28
	3	-	26	29

RF37: +3 lbs

8.2.4 R47



R47 AD.. , n _e = 1700 rpm										2660 lb-in	
i [ratio]	n _a [rpm]	T _a max [lb-in]	P _e [HP]	F _{Ra} ¹⁾ [lb]	F _{Re} [lb]	Stages		φ _(/R) [']			
						Lg	Sm				
23.59	72	2660	3.2	770	330	3	-	8	-		
26.70	64	2660	2.8	840	330	3	-	8	-		
26.74	64	2660	2.8	840	260	2	-	7	-		
29.88	57	2660	2.5	880	330	3	-	8	-		
31.12	55	1810	1.6	970	120	2	-	7	-		
33.79	50	1990	1.6	990	80	2	-	7	-		
34.73	49	2660	2.2	940	340	3	-	8	-		
36.93	46	2660	2.0	960	340	3	-	8	-		
42.87	40	2660	1.8	1020	340	3	-	8	-		
47.75	36	2660	1.6	1070	270	3	-	8	-		
52.69	32	2660	1.4	1110	280	3	-	8	-		
56.73	30	2660	1.3	1150	280	3	-	8	-		R47 AD2
64.21	26	2660	1.2	1210	290	3	-	8	-		
68.54	25	2660	1.1	1220	290	3	-	8	-		
76.23	22	2660	0.98	1220	370	3	-	7	-		
84.90	20	2660	0.88	1220	370	3	-	7	-		
93.68	18	2660	0.80	1220	370	3	-	7	-		
100.86	17	2660	0.74	1220	370	3	-	7	-		
114.17	15	2660	0.66	1220	370	3	-	7	-		
121.87	14	2660	0.62	1220	370	3	-	7	-		
139.99	12	2660	0.54	1220	370	3	-	7	-		
162.94	10	2660	0.46	1220	370	3	-	7	-		
176.88	9.6	2660	0.42	1220	370	3	-	7	-		
3.83	444	1270	9.2	430	400	2	-	11	M2		
4.34	392	1290	8.3	450	410	2	-	11	-		
4.85	351	1330	7.6	470	410	2	-	10	-		
5.64	301	1370	6.8	500	420	2	-	10	-		
6.00	283	1380	6.4	510	420	2	-	10	-		
6.96	244	1410	5.6	540	430	2	-	10	-		
7.76	219	1440	5.2	560	430	2	-	10	-		
8.01	212	1810	6.3	560	470	2	-	8	-		
9.07	187	1950	6.0	550	470	2	-	8	-		
10.15	167	2040	5.6	560	470	2	-	7	-		
11.79	144	2170	5.1	580	470	2	-	7	-		
12.54	136	2210	4.9	590	470	2	-	7	-		R47 AD3
14.56	117	2350	4.5	610	470	2	-	7	-		
16.22	105	2430	4.2	630	470	2	-	7	-		
19.27	88	2610	3.8	640	460	2	-	7	-		
23.59	72	2660	3.2	770	540	3	-	8	-		
26.70	64	2660	2.8	840	540	3	-	8	-		
29.88	57	2660	2.5	880	550	3	-	8	-		
34.73	49	2660	2.2	940	550	3	-	8	-		
36.93	46	2660	2.0	960	550	3	-	8	-		
42.87	40	2660	1.8	1020	550	3	-	8	-		
47.75	36	2660	1.6	1070	560	3	-	8	-		
56.73	30	2660	1.3	1150	560	3	-	8	-		

Weight [lbs]	Stages		AD2	AD3
	Large	Small		
R47	2	-	36	43
	3	-	38	45

RF47: +1 lbs

8.2.5 R47R37

R47R37 AD.. , n_e = 1700 rpm 2660 lb-in

i [ratio]	n _a [rpm]	T _{a max} [lb-in]	P _e [HP]	F _{Ra} ¹⁾ [lb]	F _{Re} [lb]	Stages		φ [(R)]		
						Lg	Sm			
98	17	2660	0.78	1220	130	2	2	-	-	
109	16	2660	0.70	1220	130	2	2	-	-	
129	13	2660	0.59	1220	130	2	2	-	-	
154	11	2660	0.49	1220	160	2	2	-	-	
182	9.3	2660	0.42	1220	160	2	2	-	-	
195	8.7	2660	0.39	1220	160	2	2	-	-	
228	7.5	2660	0.33	1220	160	2	2	-	-	
255	6.7	2660	0.30	1220	160	2	2	-	-	
301	5.6	2660	0.25	1220	160	2	2	-	-	
344	4.9	2660	0.22	1220	170	3	2	-	-	
348	4.9	2660	0.22	1220	160	2	2	-	-	
372	4.6	2660	0.20	1220	160	2	2	-	-	
408	4.2	2660	0.19	1220	170	3	2	-	-	
429	4.0	2660	0.18	1220	160	2	2	-	-	
436	3.9	2660	0.18	1220	170	3	2	-	-	
471	3.6	2660	0.16	1220	170	2	3	-	-	
502	3.4	2660	0.15	1220	160	2	2	-	-	
510	3.3	2660	0.15	1220	170	3	2	-	-	
546	3.1	2660	0.14	1220	160	2	2	-	-	
554	3.1	2660	0.14	1220	170	2	3	-	-	
572	3.0	2660	0.14	1220	170	3	2	-	-	
624	2.7	2660	0.12	1220	170	2	3	-	-	
673	2.5	2660	0.11	1220	170	3	2	-	-	
708	2.4	2660	0.11	1220	170	2	3	-	-	
755	2.3	2660	0.10	1220	170	2	3	-	-	
804	2.1	2660	0.10	1220	170	3	2	-	-	
863	2.0	2660	0.09	1220	170	2	3	-	-	
927	1.8	2660	0.08	1220	170	2	3	-	-	
955	1.8	2660	0.08	1220	170	3	2	-	-	
1020	1.7	2660	0.08	1220	170	3	2	-	-	R47R37
1074	1.6	2660	0.07	1220	170	2	3	-	-	AD1
1179	1.4	2660	0.07	1220	170	2	3	-	-	
1193	1.4	2660	0.06	1220	170	3	2	-	-	
1336	1.3	2660	0.06	1220	170	2	3	-	-	
1425	1.2	2660	0.05	1220	170	2	3	-	-	
1573	1.1	2660	0.05	1220	170	3	2	-	-	
1630	1.0	2660	0.05	1220	170	2	3	-	-	
1749	0.97	2660	0.04	1220	170	2	3	-	-	
1821	0.93	2660	0.04	1220	170	3	2	-	-	
1948	0.87	2660	0.04	1220	170	3	2	-	-	
2029	0.84	2660	0.04	1220	170	2	3	-	-	
2246	0.76	2660	0.03	1220	170	3	2	-	-	
2383	0.71	2660	0.03	1220	170	2	3	-	-	
2463	0.69	2660	0.03	1220	170	3	3	-	-	
2598	0.65	2660	0.03	1220	170	2	3	-	-	
2625	0.65	2660	0.03	1220	170	3	2	-	-	
2856	0.60	2660	0.03	1220	170	3	2	-	-	
2898	0.59	2660	0.03	1220	170	3	3	-	-	
3268	0.52	2660	0.02	1220	170	3	3	-	-	
3704	0.46	2660	0.02	1220	170	3	3	-	-	
3951	0.43	2660	0.02	1220	170	3	3	-	-	
4520	0.38	2660	0.02	1220	170	3	3	-	-	
4849	0.35	2660	0.02	1220	170	3	3	-	-	
5624	0.30	2660	0.01	1220	170	3	3	-	-	
6171	0.28	2660	0.01	1220	170	3	3	-	-	
6993	0.24	2660	0.01	1220	170	3	3	-	-	
7460	0.23	2660	0.01	1220	170	3	3	-	-	
8534	0.20	2660	0.01	1220	170	3	3	-	-	

R47R37 AD.. , n_e = 1700 rpm

2660 lb-in

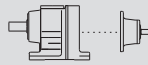

i [ratio]	n _a [rpm]	T _{a max} [lb-in]	P _e [HP]	F _{Ra} ¹⁾ [lb]	F _{Re} [lb]	Stages		φ ^(R) [°]			
						Lg	Sm				
9155	0.19	2660	0.01	1220	170	3	3	-	-		
10619	0.16	2660	0.01	1220	170	3	3	-	-		
12472	0.14	2660	0.01	1220	170	3	3	-	-		
13598	0.13	2660	0.01	1220	170	3	3	-	-		
98	17	2660	0.78	1220	370	2	2	-	-		
109	16	2660	0.70	1220	380	2	2	-	-		
129	13	2660	0.59	1220	380	2	2	-	-		
154	11	2660	0.49	1220	390	2	2	-	-		
182	9.3	2660	0.42	1220	390	2	2	-	-		
195	8.7	2660	0.39	1220	390	2	2	-	-		
228	7.5	2660	0.33	1220	390	2	2	-	-		
255	6.7	2660	0.30	1220	390	2	2	-	-		
301	5.6	2660	0.25	1220	390	2	2	-	-		
344	4.9	2660	0.22	1220	390	3	2	-	-		
348	4.9	2660	0.22	1220	390	2	2	-	-		
372	4.6	2660	0.20	1220	390	2	2	-	-		
408	4.2	2660	0.19	1220	400	3	2	-	-		
429	4.0	2660	0.18	1220	390	2	2	-	-		
436	3.9	2660	0.18	1220	400	3	2	-	-		
471	3.6	2660	0.16	1220	400	2	3	-	-		
502	3.4	2660	0.15	1220	390	2	2	-	-		
510	3.3	2660	0.15	1220	400	3	2	-	-		
546	3.1	2660	0.14	1220	390	2	2	-	-		
554	3.1	2660	0.14	1220	400	2	3	-	-		
572	3.0	2660	0.14	1220	400	3	2	-	-		
624	2.7	2660	0.12	1220	400	2	3	-	-		
673	2.5	2660	0.11	1220	400	3	2	-	-		
708	2.4	2660	0.11	1220	400	2	3	-	-		
755	2.3	2660	0.10	1220	400	2	3	-	-		
804	2.1	2660	0.10	1220	400	3	2	-	-		
863	2.0	2660	0.09	1220	400	2	3	-	-		
927	1.8	2660	0.08	1220	400	2	3	-	-		
955	1.8	2660	0.08	1220	400	3	2	-	-		
1020	1.7	2660	0.08	1220	400	3	2	-	-		
1074	1.6	2660	0.07	1220	400	2	3	-	-		
1179	1.4	2660	0.07	1220	400	2	3	-	-		
1193	1.4	2660	0.06	1220	400	3	2	-	-		
1336	1.3	2660	0.06	1220	400	2	3	-	-		
1425	1.2	2660	0.05	1220	400	2	3	-	-		
1573	1.1	2660	0.05	1220	400	3	2	-	-		
1630	1.0	2660	0.05	1220	400	2	3	-	-		
1749	0.97	2660	0.04	1220	400	2	3	-	-		
1821	0.93	2660	0.04	1220	400	3	2	-	-		
1948	0.87	2660	0.04	1220	400	3	2	-	-		
2029	0.84	2660	0.04	1220	400	2	3	-	-		
2246	0.76	2660	0.03	1220	400	3	2	-	-		
2383	0.71	2660	0.03	1220	400	2	3	-	-		
2463	0.69	2660	0.03	1220	400	3	3	-	-		
2598	0.65	2660	0.03	1220	400	2	3	-	-		
2625	0.65	2660	0.03	1220	400	3	2	-	-		
2856	0.60	2660	0.03	1220	400	3	2	-	-		
2898	0.59	2660	0.03	1220	400	3	3	-	-		
3268	0.52	2660	0.02	1220	400	3	3	-	-		
3704	0.46	2660	0.02	1220	400	3	3	-	-		
3951	0.43	2660	0.02	1220	400	3	3	-	-		
4520	0.38	2660	0.02	1220	400	3	3	-	-		
4849	0.35	2660	0.02	1220	400	3	3	-	-		
5624	0.30	2660	0.01	1220	400	3	3	-	-		
6171	0.28	2660	0.01	1220	400	3	3	-	-		

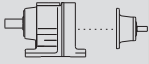
R47R37 AD.. , n_e = 1700 rpm 2660 lb-in

i [ratio]	n _a [rpm]	T _{a max} [lb-in]	P _e [HP]	F _{Ra} ¹⁾ [lb]	F _{Re} [lb]	Stages		φ ^(R) [°]		
						Lg	Sm			
6993	0.24	2660	0.01	1220	400	3	3	-	-	R47R37 AD2
7460	0.23	2660	0.01	1220	400	3	3	-	-	
8534	0.20	2660	0.01	1220	400	3	3	-	-	
9155	0.19	2660	0.01	1220	400	3	3	-	-	
10619	0.16	2660	0.01	1220	400	3	3	-	-	
12472	0.14	2660	0.01	1220	400	3	3	-	-	
13598	0.13	2660	0.01	1220	400	3	3	-	-	

Weight [lbs]	Stages		AD1	AD2
	Large	Small		
R47R37	2	2	57	60
	2	3	58	61
	3	2	57	60
	3	3	58	61
RF47: +1 lbs				

8.2.6 R57

R57 AD.. , n _e = 1700 rpm										3980 lb-in		
i [ratio]	n _a [rpm]	T _a max [lb-in]	P _e [HP]	F _{Ra} ¹⁾ [lb]	F _{Re} [lb]	Stages		φ _(/R) [']				
						Lg	Sm					
26.97	63	3980	4.2	990	300	3	-	8	-			
30.18	56	3980	3.7	1040	300	3	-	8	-			
35.07	48	3980	3.2	1110	310	3	-	8	-			
37.30	46	3980	3.0	1140	310	3	-	8	-			
43.30	39	3980	2.6	1220	320	3	-	8	-			
48.23	35	3980	2.3	1280	320	3	-	8	-			
53.22	32	3980	2.1	1330	320	3	-	8	-			
57.29	30	3980	2.0	1370	320	3	-	8	-			
64.85	26	3980	1.7	1450	330	3	-	8	-			
69.23	25	3980	1.6	1490	200	3	-	7	-		R57	AD2
80.55	21	3980	1.4	1580	310	3	-	7	-			
89.71	19	3980	1.3	1600	320	3	-	7	-			
98.99	17	3980	1.1	1600	320	3	-	7	-			
106.58	16	3980	1.1	1600	330	3	-	7	-			
120.63	14	3980	0.93	1600	330	3	-	7	-			
128.77	13	3980	0.87	1600	340	3	-	7	-			
147.92	11	3980	0.76	1600	340	3	-	7	-			
172.17	9.9	3980	0.65	1600	350	3	-	7	-			
186.89	9.1	3980	0.60	1600	350	3	-	7	-			
4.39	387	2480	15.7	310	290	2	-	10	M1-6			
5.05	337	2700	14.9	270	280	2	-	10	M1-6			
5.82	292	2830	13.5	280	290	2	-	10	M1-6			
6.41	265	2960	12.8	270	280	2	-	9	M1-6			
7.53	226	3100	11.4	300	290	2	-	9	M1-6			
7.97	213	3140	11.0	320	290	2	-	9	M2			
9.06	188	2960	9.1	510	320	2	-	9	-			
9.35	182	3270	9.7	610	390	2	-	7	M2			
10.79	158	3450	8.9	630	400	2	-	7	-			
11.88	143	3580	8.4	650	400	2	-	7	-			
13.95	122	3810	7.6	670	400	2	-	7	-			
14.77	115	3850	7.2	700	400	2	-	7	-			
16.79	101	3980	6.6	740	400	2	-	7	-		R57	AD3
18.60	91	3980	5.9	830	410	2	-	7	-			
21.93	78	3980	5.0	900	420	2	-	7	-			
26.97	63	3980	4.2	990	510	3	-	8	-			
30.18	56	3980	3.7	1040	520	3	-	8	-			
35.07	48	3980	3.2	1110	520	3	-	8	-			
37.30	46	3980	3.0	1140	520	3	-	8	-			
43.30	39	3980	2.6	1220	530	3	-	8	-			
48.23	35	3980	2.3	1280	530	3	-	8	-			
57.29	30	3980	2.0	1370	540	3	-	8	-			
80.55	21	3980	1.4	1580	570	3	-	7	-			
89.71	19	3980	1.3	1600	570	3	-	7	-			
106.58	16	3980	1.1	1600	570	3	-	7	-			

Weight [lbs]	Stages		AD1	AD2
	Large	Small		
R57	2	-	47	54
	3	-	49	56

RF57: +8 lbs / RM57: +34 lbs

8.2.7 R57R37

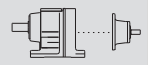
R57R37 AD.. , n _e = 1700 rpm										3980 lb-in
i [ratio]	n _a [rpm]	T _a max [lb-in]	P _e [HP]	F _{Ra} ¹⁾ [lb]	F _{Re} [lb]	Stages		φ (/R) [']		
						Lg	Sm			
134	13	3980	0.85	1600	140	2	2	-	-	
142	12	3980	0.82	1600	130	3	2	-	-	
146	12	3980	0.78	1600	110	2	2	-	-	
159	11	3980	0.72	1600	140	2	2	-	-	
164	10	3980	0.71	1600	150	3	2	-	-	
187	9.1	3980	0.62	1600	150	3	2	-	-	
188	9.0	3980	0.61	1600	150	2	2	-	-	
215	7.9	3980	0.54	1600	160	3	2	-	-	
220	7.7	3980	0.52	1600	150	2	2	-	-	
241	7.1	3980	0.48	1600	160	3	2	-	-	
246	6.9	3980	0.46	1600	160	2	2	-	-	
262	6.5	3980	0.44	1600	150	2	2	-	-	
273	6.2	3980	0.42	1600	160	3	2	-	-	
290	5.9	3980	0.39	1600	160	2	2	-	-	
319	5.3	3980	0.36	1600	160	3	2	-	-	
324	5.2	3980	0.35	1600	160	2	2	-	-	
357	4.8	3980	0.32	1600	160	3	2	-	-	
359	4.7	3980	0.32	1600	160	2	2	-	-	
410	4.1	3980	0.28	1600	160	2	3	-	-	
454	3.7	3980	0.26	1600	170	2	3	-	-	
471	3.6	3980	0.25	1600	160	3	2	-	-	
534	3.2	3980	0.22	1600	170	2	3	-	-	
537	3.2	3980	0.22	1600	160	3	2	-	-	
603	2.8	3980	0.19	1600	170	2	3	-	-	
604	2.8	3980	0.19	1600	170	3	2	-	-	
678	2.5	3980	0.17	1600	170	3	2	-	-	
683	2.5	3980	0.17	1600	170	2	3	-	-	
782	2.2	3980	0.15	1600	170	3	2	-	-	
805	2.1	3980	0.14	1600	170	2	3	-	-	
894	1.9	3980	0.13	1600	170	2	3	-	-	
1027	1.7	3980	0.11	1600	170	2	3	-	-	
1034	1.6	3980	0.11	1600	170	3	2	-	-	
1164	1.5	3980	0.10	1600	170	2	3	-	-	
1189	1.4	3980	0.10	1600	170	3	2	-	-	
1342	1.3	3980	0.09	1600	170	2	3	-	-	
1399	1.2	3980	0.08	1600	170	3	2	-	-	
1520	1.1	3980	0.08	1600	170	2	3	-	-	
1555	1.1	3980	0.07	1600	170	3	2	-	-	
1732	0.98	3980	0.07	1600	170	3	2	-	-	
1768	0.96	3980	0.07	1600	170	2	3	-	-	
1967	0.86	3980	0.06	1600	170	3	3	-	-	
1991	0.85	3980	0.06	1600	170	2	3	-	-	
2244	0.76	3980	0.05	1600	170	3	3	-	-	
2309	0.74	3980	0.05	1600	170	2	3	-	-	
2508	0.68	3980	0.05	1600	170	2	3	-	-	
2567	0.66	3980	0.05	1600	170	3	3	-	-	
2907	0.58	3980	0.04	1600	170	3	3	-	-	
2957	0.57	3980	0.04	1600	170	2	3	-	-	
3344	0.51	3980	0.04	1600	170	3	3	-	-	
3873	0.44	3980	0.03	1600	170	3	3	-	-	
4378	0.39	3980	0.03	1600	170	3	3	-	-	
4928	0.34	3980	0.02	1600	170	3	3	-	-	
5585	0.30	3980	0.02	1600	170	3	3	-	-	
6521	0.26	3980	0.02	1600	170	3	3	-	-	
7312	0.23	3980	0.02	1600	170	3	3	-	-	
8480	0.20	3980	0.01	1600	170	3	3	-	-	
9445	0.18	3980	0.01	1600	170	3	3	-	-	
10860	0.16	3980	0.01	1600	170	3	3	-	-	
12095	0.14	3980	0.01	1600	170	3	3	-	-	
14369	0.12	3980	0.01	1600	170	3	3	-	-	

R57R37

AD1

R57R37 AD.. , n_e = 1700 rpm 3980 lb-in

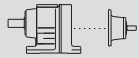
i	n _a	T _{a max}	P _e	F _{Ra} ¹⁾	F _{Re}	Stages		φ (/R)	⚠	
						Lg	Sm			
[ratio]	[rpm]	[lb-in]	[HP]	[lb]	[lb]			[']		
134	13	3980	0.85	1600	380	2	2	-	-	
142	12	3980	0.82	1600	380	3	2	-	-	
146	12	3980	0.78	1600	370	2	2	-	-	
159	11	3980	0.72	1600	380	2	2	-	-	
164	10	3980	0.71	1600	380	3	2	-	-	
187	9.1	3980	0.62	1600	380	3	2	-	-	
188	9.0	3980	0.61	1600	380	2	2	-	-	
215	7.9	3980	0.54	1600	390	3	2	-	-	
220	7.7	3980	0.52	1600	380	2	2	-	-	
241	7.1	3980	0.48	1600	390	3	2	-	-	
246	6.9	3980	0.46	1600	380	2	2	-	-	
262	6.5	3980	0.44	1600	380	2	2	-	-	
273	6.2	3980	0.42	1600	390	3	2	-	-	
290	5.9	3980	0.39	1600	390	2	2	-	-	
319	5.3	3980	0.36	1600	390	3	2	-	-	
324	5.2	3980	0.35	1600	380	2	2	-	-	
357	4.8	3980	0.32	1600	390	3	2	-	-	
359	4.7	3980	0.32	1600	390	2	2	-	-	
410	4.1	3980	0.28	1600	390	2	3	-	-	
454	3.7	3980	0.26	1600	390	2	3	-	-	
471	3.6	3980	0.25	1600	390	3	2	-	-	
534	3.2	3980	0.22	1600	390	2	3	-	-	
537	3.2	3980	0.22	1600	390	3	2	-	-	
603	2.8	3980	0.19	1600	390	2	3	-	-	
604	2.8	3980	0.19	1600	390	3	2	-	-	
678	2.5	3980	0.17	1600	400	3	2	-	-	
683	2.5	3980	0.17	1600	390	2	3	-	-	
782	2.2	3980	0.15	1600	390	3	2	-	-	
805	2.1	3980	0.14	1600	400	2	3	-	-	
894	1.9	3980	0.13	1600	400	2	3	-	-	
1027	1.7	3980	0.11	1600	400	2	3	-	-	
1034	1.6	3980	0.11	1600	400	3	2	-	-	
1164	1.5	3980	0.10	1600	400	2	3	-	-	
1189	1.4	3980	0.10	1600	400	3	2	-	-	
1342	1.3	3980	0.09	1600	400	2	3	-	-	
1399	1.2	3980	0.08	1600	400	3	2	-	-	
1520	1.1	3980	0.08	1600	400	2	3	-	-	
1555	1.1	3980	0.07	1600	400	3	2	-	-	
1732	0.98	3980	0.07	1600	400	3	2	-	-	
1768	0.96	3980	0.07	1600	400	2	3	-	-	
1967	0.86	3980	0.06	1600	400	3	3	-	-	
1991	0.85	3980	0.06	1600	400	2	3	-	-	
2244	0.76	3980	0.05	1600	400	3	3	-	-	
2309	0.74	3980	0.05	1600	400	2	3	-	-	
2508	0.68	3980	0.05	1600	400	2	3	-	-	
2567	0.66	3980	0.05	1600	400	3	3	-	-	
2907	0.58	3980	0.04	1600	400	3	3	-	-	
2957	0.57	3980	0.04	1600	400	2	3	-	-	
3344	0.51	3980	0.04	1600	400	3	3	-	-	
3873	0.44	3980	0.03	1600	400	3	3	-	-	
4378	0.39	3980	0.03	1600	400	3	3	-	-	
4928	0.34	3980	0.02	1600	400	3	3	-	-	
5585	0.30	3980	0.02	1600	400	3	3	-	-	
6521	0.26	3980	0.02	1600	400	3	3	-	-	
7312	0.23	3980	0.02	1600	400	3	3	-	-	
8480	0.20	3980	0.01	1600	400	3	3	-	-	
9445	0.18	3980	0.01	1600	400	3	3	-	-	
10860	0.16	3980	0.01	1600	400	3	3	-	-	
12095	0.14	3980	0.01	1600	400	3	3	-	-	
14369	0.12	3980	0.01	1600	400	3	3	-	-	



R57R37

AD2

Weight [lbs]	Stages		AD1	AD2
	Large	Small		
R57R37	2	2	68	71
	2	3	69	72
	3	2	70	73
	3	3	71	74

RF57: +8 lbs / RM57: +34 lbs



8.2.8 R67

R67 AD.. , $n_e = 1700$ rpm										5310 lb-in		
i [ratio]	n_a [rpm]	T_a max [lb-in]	P_e [HP]	$F_{Ra}^{1)}$ [lb]	F_{Re} [lb]	Stages		ϕ (/R) [']			R67	AD2
						Lg	Sm					
28.83	59	4600	4.5	1890	280	3	-	7	-			
32.27	53	4780	4.2	1850	290	3	-	7	-			
37.50	45	5040	3.8	1780	290	3	-	7	-			
39.88	43	5130	3.6	1750	290	3	-	7	-			
46.29	37	5310	3.2	1700	290	3	-	7	-			
51.56	33	5310	2.9	1700	290	3	-	7	-			
56.89	30	5310	2.6	1700	300	3	-	7	-			
61.26	28	5310	2.4	1700	300	3	-	7	-			
69.75	24	5310	2.1	1700	340	3	-	7	-			
74.17	23	5310	2.0	1700	340	3	-	7	-			
86.11	20	5310	1.7	1700	340	3	-	6	-			
95.91	18	5310	1.6	1700	270	3	-	6	-			
105.83	16	5310	1.4	1700	280	3	-	6	-			
113.94	15	5310	1.3	1700	280	3	-	6	-			
128.97	13	5310	1.2	1700	290	3	-	6	-			
137.67	12	5310	1.1	1700	290	3	-	6	-			
158.14	11	5310	0.95	1700	300	3	-	6	-			
184.07	9.2	5310	0.81	1700	300	3	-	6	-			
199.81	8.5	5310	0.75	1700	310	3	-	6	-			
4.29	396	2390	15.5	1040	280	2	-	10	M1-6			
4.93	345	2570	14.5	1090	270	2	-	9	M1-6			
5.70	298	2740	13.4	1130	270	2	-	9	-			
6.27	271	2920	12.9	1150	260	2	-	9	-			
7.36	231	3270	12.4	1100	220	2	-	8	-			
7.79	218	3360	12.0	1110	220	2	-	8	-			
8.70	195	3890	12.4	1190	340	2	-	7	M2			
10.00	170	4160	11.6	1200	340	2	-	7	-			
11.54	147	4430	10.7	1230	340	2	-	7	-			
12.70	134	4600	10.1	1260	340	2	-	6	-			
14.91	114	4870	9.1	1320	350	2	-	6	-			
15.79	108	4960	8.7	1350	350	2	-	6	-			
17.95	95	5220	8.1	1380	340	2	-	6	-			
19.89	85	5310	7.4	1480	340	2	-	6	-			
23.44	73	4960	5.9	1760	370	2	-	6	-			
28.83	59	4600	4.5	1890	500	3	-	7	-			
32.27	53	4780	4.2	1850	500	3	-	7	-			
37.50	45	5040	3.8	1780	500	3	-	7	-			
39.88	43	5130	3.6	1750	500	3	-	7	-			
46.29	37	5310	3.2	1700	500	3	-	7	-			
51.56	33	5310	2.9	1700	510	3	-	7	-			
61.26	28	5310	2.4	1700	510	3	-	7	-			
69.75	24	5310	2.1	1700	550	3	-	7	-			
74.17	23	5310	2.0	1700	550	3	-	7	-			
86.11	20	5310	1.7	1700	550	3	-	6	-			
95.91	18	5310	1.6	1700	560	3	-	6	-			
113.94	15	5310	1.3	1700	560	3	-	6	-			

Weight [lbs]	Stages		AD2	AD3
	Large	Small		
R67	2	-	62	69
	3	-	64	71

RF67: +7 lbs / RM67: +41 lbs



8.2.9 R67R37

R67R37 AD.. , n _e = 1700 rpm										5310 lb-in	
i [ratio]	n _a [rpm]	T _{a max} [lb-in]	P _e [HP]	F _{Ra} ¹⁾ [lb]	F _{Re} [lb]	Stages		φ _(/R) [']			
						Lg	Sm				
158	11	5310	0.98	1700	130	3	2	-	-		
159	11	5310	0.96	1700	130	2	2	-	-		
176	9.7	5310	0.88	1700	140	3	2	-	-		
181	9.4	5310	0.84	1700	130	2	2	-	-		
200	8.5	5310	0.77	1700	140	3	2	-	-		
201	8.5	5310	0.76	1700	140	2	2	-	-		
234	7.3	5310	0.66	1700	140	3	2	-	-		
235	7.2	5310	0.65	1700	140	2	2	-	-		
261	6.5	5310	0.59	1700	150	3	2	-	-		
264	6.4	5310	0.58	1700	140	2	2	-	-		
294	5.8	5310	0.53	1700	160	3	2	-	-		
310	5.5	5310	0.49	1700	150	2	2	-	-		
344	4.9	5310	0.45	1700	150	3	2	-	-		
359	4.7	5310	0.42	1700	150	2	2	-	-		
384	4.4	5310	0.40	1700	150	2	2	-	-		
388	4.4	5310	0.40	1700	160	3	2	-	-		
438	3.9	5310	0.35	1700	160	3	2	-	-		
443	3.8	5310	0.34	1700	150	2	2	-	-		
486	3.5	5310	0.32	1700	160	2	3	-	-		
495	3.4	5310	0.31	1700	160	3	2	-	-		
571	3.0	5310	0.27	1700	160	2	3	-	-		
574	3.0	5310	0.27	1700	160	3	2	-	-		
644	2.6	5310	0.24	1700	160	2	3	-	-		
646	2.6	5310	0.24	1700	160	3	2	-	-		
730	2.3	5310	0.21	1700	170	2	3	-	-		
750	2.3	5310	0.21	1700	170	3	2	-	-		
836	2.0	5310	0.18	1700	170	3	2	-	-		
891	1.9	5310	0.17	1700	170	2	3	-	-		
956	1.8	5310	0.16	1700	170	2	3	-	-		
1106	1.5	5310	0.14	1700	170	3	2	-	-	R67R37	AD1
1109	1.5	5310	0.14	1700	170	2	3	-	-		
1259	1.4	5310	0.12	1700	170	3	2	-	-		
1379	1.2	5310	0.11	1700	170	2	3	-	-		
1432	1.2	5310	0.11	1700	170	3	2	-	-		
1471	1.2	5310	0.11	1700	170	2	3	-	-		
1629	1.0	5310	0.09	1700	170	2	3	-	-		
1652	1.0	5310	0.09	1700	170	3	2	-	-		
1805	0.94	5310	0.09	1700	170	2	3	-	-		
1852	0.92	5310	0.08	1700	170	3	2	-	-		
2094	0.81	5310	0.07	1700	170	2	3	-	-		
2136	0.80	5310	0.07	1700	170	3	2	-	-		
2403	0.71	5310	0.07	1700	170	3	3	-	-		
2460	0.69	5310	0.06	1700	170	2	3	-	-		
2682	0.63	5310	0.06	1700	170	2	3	-	-		
2745	0.62	5310	0.06	1700	170	3	3	-	-		
3125	0.54	5310	0.05	1700	170	3	3	-	-		
3566	0.48	5310	0.04	1700	170	3	3	-	-		
4136	0.41	5310	0.04	1700	170	3	3	-	-		
4680	0.36	5310	0.03	1700	170	3	3	-	-		
5268	0.32	5310	0.03	1700	170	3	3	-	-		
5970	0.28	5310	0.03	1700	170	3	3	-	-		
6732	0.25	5310	0.02	1700	170	3	3	-	-		
7816	0.22	5310	0.02	1700	170	3	3	-	-		
9066	0.19	5310	0.02	1700	170	3	3	-	-		
10097	0.17	5310	0.02	1700	170	3	3	-	-		
11996	0.14	5310	0.01	1700	170	3	3	-	-		
12931	0.13	5310	0.01	1700	170	3	3	-	-		
15361	0.11	5310	0.01	1700	170	3	3	-	-		

8

R67R37 AD.. , n_e = 1700 rpm

5310 lb-in

i [ratio]	n _a [rpm]	T _{a max} [lb-in]	P _e [HP]	F _{Ra} ¹⁾ [lb]	F _{Re} [lb]	Stages		φ (/R) [']		
						Lg	Sm			
158	11	5310	0.98	1700	370	3	2	-	-	
159	11	5310	0.96	1700	370	2	2	-	-	
176	9.7	5310	0.88	1700	380	3	2	-	-	
181	9.4	5310	0.84	1700	370	2	2	-	-	
200	8.5	5310	0.77	1700	380	3	2	-	-	
201	8.5	5310	0.76	1700	380	2	2	-	-	
234	7.3	5310	0.66	1700	380	3	2	-	-	
235	7.2	5310	0.65	1700	380	2	2	-	-	
261	6.5	5310	0.59	1700	380	3	2	-	-	
264	6.4	5310	0.58	1700	380	2	2	-	-	
294	5.8	5310	0.53	1700	390	3	2	-	-	
310	5.5	5310	0.49	1700	380	2	2	-	-	
344	4.9	5310	0.45	1700	380	3	2	-	-	
359	4.7	5310	0.42	1700	380	2	2	-	-	
384	4.4	5310	0.40	1700	380	2	2	-	-	
388	4.4	5310	0.40	1700	390	3	2	-	-	
438	3.9	5310	0.35	1700	390	3	2	-	-	
443	3.8	5310	0.34	1700	380	2	2	-	-	
486	3.5	5310	0.32	1700	390	2	3	-	-	
495	3.4	5310	0.31	1700	390	3	2	-	-	
571	3.0	5310	0.27	1700	390	2	3	-	-	
574	3.0	5310	0.27	1700	390	3	2	-	-	
644	2.6	5310	0.24	1700	390	2	3	-	-	
646	2.6	5310	0.24	1700	390	3	2	-	-	
730	2.3	5310	0.21	1700	390	2	3	-	-	
750	2.3	5310	0.21	1700	390	3	2	-	-	
836	2.0	5310	0.18	1700	390	3	2	-	-	
891	1.9	5310	0.17	1700	390	2	3	-	-	
956	1.8	5310	0.16	1700	390	2	3	-	-	
1106	1.5	5310	0.14	1700	390	3	2	-	-	
1109	1.5	5310	0.14	1700	390	2	3	-	-	
1259	1.4	5310	0.12	1700	400	3	2	-	-	
1379	1.2	5310	0.11	1700	400	2	3	-	-	
1432	1.2	5310	0.11	1700	400	3	2	-	-	
1471	1.2	5310	0.11	1700	400	2	3	-	-	
1629	1.0	5310	0.09	1700	400	2	3	-	-	
1652	1.0	5310	0.09	1700	400	3	2	-	-	
1805	0.94	5310	0.09	1700	400	2	3	-	-	
1852	0.92	5310	0.08	1700	400	3	2	-	-	
2094	0.81	5310	0.07	1700	400	2	3	-	-	
2136	0.80	5310	0.07	1700	400	3	2	-	-	
2403	0.71	5310	0.07	1700	400	3	3	-	-	
2460	0.69	5310	0.06	1700	400	2	3	-	-	
2682	0.63	5310	0.06	1700	400	2	3	-	-	
2745	0.62	5310	0.06	1700	400	3	3	-	-	
3125	0.54	5310	0.05	1700	400	3	3	-	-	
3566	0.48	5310	0.04	1700	400	3	3	-	-	
4136	0.41	5310	0.04	1700	400	3	3	-	-	
4680	0.36	5310	0.03	1700	400	3	3	-	-	
5268	0.32	5310	0.03	1700	400	3	3	-	-	
5970	0.28	5310	0.03	1700	400	3	3	-	-	
6732	0.25	5310	0.02	1700	400	3	3	-	-	
7816	0.22	5310	0.02	1700	400	3	3	-	-	
9066	0.19	5310	0.02	1700	400	3	3	-	-	
10097	0.17	5310	0.02	1700	400	3	3	-	-	
11996	0.14	5310	0.01	1700	400	3	3	-	-	
12931	0.13	5310	0.01	1700	400	3	3	-	-	
15361	0.11	5310	0.01	1700	400	3	3	-	-	

R67R37

AD2



Weight [lbs]	Stages		AD1	AD2
	Large	Small		
R67R37	2	2	83	85
	2	3	84	86
	3	2	85	87
	3	3	86	88

RF67: +7 lbs / RM67: +41 lbs

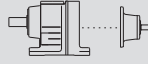
8.2.10 R77



R77 AD.. , n _e = 1700 rpm										7260 lb-in		
i [ratio]	n _a [rpm]	T _a max [lb-in]	P _e [HP]	F _{Ra} ¹⁾ [lb]	F _{Re} [lb]	Stages		φ (/R) [°]				
						Lg	Sm					
25.23	67	6900	7.7	1950	250	3	-	7	-			
29.00	59	7260	7.1	2030	250	3	-	7	-			
33.47	51	7260	6.1	2230	260	3	-	7	-			
36.83	46	7260	5.6	2230	260	3	-	7	-			
43.26	39	7260	4.7	2230	270	3	-	7	-			
45.81	37	7260	4.5	2230	280	3	-	7	-			
52.07	33	7260	3.9	2230	280	3	-	7	-			
57.68	29	7260	3.6	2230	280	3	-	7	-			
65.77	26	7260	3.1	2230	320	3	-	7	-			
77.24	22	7260	2.7	2230	330	3	-	7	-			
81.80	21	7260	2.5	2230	330	3	-	6	-			
92.97	18	7260	2.2	2230	330	3	-	6	-			
102.99	17	7260	2.0	2230	340	3	-	6	-			
121.42	14	7260	1.7	2230	340	3	-	6	-			
138.39	12	7260	1.5	2230	250	3	-	6	-			
145.67	12	7260	1.4	2230	250	3	-	6	-			
166.59	10	7260	1.2	2230	250	3	-	6	-			
195.24	8.7	7260	1.0	2230	260	3	-	6	-			
9.64	176	5580	16.1	1190	310	2	-	7	M1-6			
10.88	156	5840	14.9	1220	310	2	-	7	M2			
12.33	138	6110	13.8	1270	310	2	-	6	-			
14.05	121	6370	12.6	1330	320	2	-	6	-			
15.60	109	6550	11.7	1390	320	2	-	6	-			
17.82	95	6900	10.8	1430	320	2	-	6	-			
18.80	90	6900	10.2	1510	320	2	-	6	-			
21.43	79	7260	9.4	1560	320	2	-	6	-			
23.37	73	7260	8.6	1690	320	2	-	6	-			
25.23	67	6900	7.7	1950	460	3	-	7	-			
29.00	59	7260	7.1	2030	470	3	-	7	-			
33.47	51	7260	6.1	2230	470	3	-	7	-			
36.83	46	7260	5.6	2230	480	3	-	7	-			
43.26	39	7260	4.7	2230	490	3	-	7	-			
45.81	37	7260	4.5	2230	490	3	-	7	-			
52.07	33	7260	3.9	2230	490	3	-	7	-			
57.68	29	7260	3.6	2230	500	3	-	7	-			
65.77	26	7260	3.1	2230	540	3	-	7	-			
77.24	22	7260	2.7	2230	540	3	-	7	-			
81.80	21	7260	2.5	2230	540	3	-	6	-			
92.97	18	7260	2.2	2230	550	3	-	6	-			
102.99	17	7260	2.0	2230	550	3	-	6	-			
121.42	14	7260	1.7	2230	550	3	-	6	-			

R77 AD.. , n_e = 1700 rpm 7260 lb-in



i [ratio]	n _a [rpm]	T _{a max} [lb-in]	P _e [HP]	F _{Ra} ¹⁾ [lb]	F _{Re} [lb]	Stages		φ (/R) [']		
						Lg	Sm			
5.31	320	4510	24	710	600	2	-	8	M1-6	R77 AD4
5.99	284	4780	22	700	600	2	-	8	M1-6	
6.79	250	5130	21	660	590	2	-	8	M1-6	
7.74	220	5400	19.4	680	590	2	-	8	M1-6	
8.59	198	5580	18.1	710	600	2	-	7	M1-6	
9.64	176	5580	16.1	1190	730	2	-	7	M1-6	
10.88	156	5840	14.9	1220	730	2	-	7	M2	
12.33	138	6110	13.8	1270	730	2	-	6	-	
14.05	121	6370	12.6	1330	730	2	-	6	-	
15.60	109	6550	11.7	1390	740	2	-	6	-	
17.82	95	6900	10.8	1430	730	2	-	6	-	
18.80	90	6900	10.2	1510	740	2	-	6	-	
25.23	67	6900	7.7	1950	860	3	-	7	-	
29.00	59	7260	7.1	2030	860	3	-	7	-	
33.47	51	7260	6.1	2230	870	3	-	7	-	
36.83	46	7260	5.6	2230	870	3	-	7	-	
43.26	39	7260	4.7	2230	880	3	-	7	-	
45.81	37	7260	4.5	2230	880	3	-	7	-	
65.77	26	7260	3.1	2230	920	3	-	7	-	
77.24	22	7260	2.7	2230	930	3	-	7	-	
81.80	21	7260	2.5	2230	930	3	-	6	-	

Weight [lbs]	Stages		AD2	AD3	AD4
	Large	Small			
R77	2	-	74	82	95
	3	-	77	85	98
RF77: +13 lbs / RM77: +68 lbs					

8.2.11 R77R37

R77R37 AD.. , n _e = 1700 rpm										7260 lb-in	
i [ratio]	n _a [rpm]	T _{a max} [lb-in]	P _e [HP]	F _{Ra} ¹⁾ [lb]	F _{Re} [lb]	Stages		φ _(/R) [']			
						Lg	Sm				
149	11	7260	1.4	2230	80	3	2	-	-		
169	10	7260	1.2	2230	80	3	2	-	-		
186	9.1	7260	1.1	2230	120	2	2	-	-		
197	8.6	7260	1.1	2230	120	3	2	-	-		
221	7.7	7260	0.94	2230	120	2	2	-	-		
224	7.6	7260	0.94	2230	130	3	2	-	-		
236	7.2	7260	0.88	2230	120	2	2	-	-		
260	6.5	7260	0.81	2230	120	3	2	-	-		
276	6.2	7260	0.75	2230	130	2	2	-	-		
289	5.9	7260	0.73	2230	120	3	2	-	-		
310	5.5	7260	0.67	2230	130	2	2	-	-		
327	5.2	7260	0.65	2230	140	3	2	-	-		
365	4.7	7260	0.57	2230	140	2	2	-	-		
373	4.6	7260	0.57	2230	140	3	2	-	-		
422	4.0	7260	0.49	2230	140	2	2	-	-		
436	3.9	7260	0.48	2230	160	3	2	-	-		
451	3.8	7260	0.46	2230	140	2	2	-	-		
488	3.5	7260	0.43	2230	160	3	2	-	-		
520	3.3	7260	0.40	2230	140	2	2	-	-		
560	3.0	7260	0.38	2230	150	3	2	-	-		
571	3.0	7260	0.37	2230	160	2	3	-	-		
646	2.6	7260	0.33	2230	160	3	2	-	-		
671	2.5	7260	0.31	2230	160	2	3	-	-		
731	2.3	7260	0.29	2230	160	3	2	-	-		
757	2.2	7260	0.28	2230	160	2	3	-	-		
821	2.1	7260	0.26	2230	170	3	2	-	-		
858	2.0	7260	0.25	2230	160	2	3	-	-		
915	1.9	7260	0.23	2230	160	2	3	-	-		
940	1.8	7260	0.22	2230	160	3	2	-	-	R77R37	AD1
1047	1.6	7260	0.20	2230	160	2	3	-	-		
1084	1.6	7260	0.19	2230	170	3	2	-	-		
1124	1.5	7260	0.19	2230	160	2	3	-	-		
1218	1.4	7260	0.17	2230	170	3	2	-	-		
1303	1.3	7260	0.16	2230	170	2	3	-	-		
1394	1.2	7260	0.15	2230	170	3	2	-	-		
1430	1.2	7260	0.15	2230	170	2	3	-	-		
1580	1.1	7260	0.13	2230	170	3	2	-	-		
1620	1.0	7260	0.13	2230	170	2	3	-	-		
1728	0.98	7260	0.12	2230	170	2	3	-	-		
1822	0.93	7260	0.12	2230	170	3	2	-	-		
1977	0.86	7260	0.11	2230	170	2	3	-	-		
2070	0.82	7260	0.10	2230	170	3	2	-	-		
2121	0.80	7260	0.10	2230	170	2	3	-	-		
2345	0.72	7260	0.09	2230	170	3	2	-	-		
2460	0.69	7260	0.09	2230	170	2	3	-	-		
2671	0.64	7260	0.08	2230	170	3	3	-	-		
2890	0.59	7260	0.07	2230	170	2	3	-	-		
3053	0.56	7260	0.07	2230	170	3	3	-	-		
3151	0.54	7260	0.07	2230	170	2	3	-	-		
3488	0.49	7260	0.06	2230	170	3	3	-	-		
3999	0.43	7260	0.05	2230	170	3	3	-	-		
4470	0.38	7260	0.05	2230	170	3	3	-	-		
5184	0.33	7260	0.04	2230	170	3	3	-	-		
5838	0.29	7260	0.04	2230	170	3	3	-	-		
6770	0.25	7260	0.03	2230	170	3	3	-	-		
7617	0.22	7260	0.03	2230	170	3	3	-	-		
8714	0.20	7260	0.02	2230	170	3	3	-	-		

8

R77R37 AD.. , n _e = 1700 rpm										7260 lb-in
i [ratio]	n _a [rpm]	T _{a max} [lb-in]	P _e [HP]	F _{Ra} ¹⁾ [lb]	F _{Re} [lb]	Stages		φ (/R) [']		
						Lg	Sm			
9788	0.17	7260	0.02	2230	170	3	3	-	-	R77R37
11021	0.15	7260	0.02	2230	170	3	3	-	-	
12783	0.13	7260	0.02	2230	170	3	3	-	-	
13885	0.12	7260	0.02	2230	170	3	3	-	-	
15015	0.11	7260	0.01	2230	170	3	3	-	-	
16370	0.10	7260	0.01	2230	170	3	3	-	-	
149	11	7260	1.4	2230	330	3	2	-	-	R77R37
169	10	7260	1.2	2230	330	3	2	-	-	
186	9.1	7260	1.1	2230	370	2	2	-	-	
197	8.6	7260	1.1	2230	370	3	2	-	-	
221	7.7	7260	0.94	2230	370	2	2	-	-	
224	7.6	7260	0.94	2230	380	3	2	-	-	
236	7.2	7260	0.88	2230	370	2	2	-	-	
260	6.5	7260	0.81	2230	370	3	2	-	-	
276	6.2	7260	0.75	2230	380	2	2	-	-	
289	5.9	7260	0.73	2230	370	3	2	-	-	
310	5.5	7260	0.67	2230	380	2	2	-	-	
327	5.2	7260	0.65	2230	380	3	2	-	-	
365	4.7	7260	0.57	2230	380	2	2	-	-	
373	4.6	7260	0.57	2230	380	3	2	-	-	
422	4.0	7260	0.49	2230	380	2	2	-	-	
436	3.9	7260	0.48	2230	380	3	2	-	-	
451	3.8	7260	0.46	2230	380	2	2	-	-	
488	3.5	7260	0.43	2230	390	3	2	-	-	
520	3.3	7260	0.40	2230	380	2	2	-	-	
560	3.0	7260	0.38	2230	380	3	2	-	-	
571	3.0	7260	0.37	2230	390	2	3	-	-	
646	2.6	7260	0.33	2230	390	3	2	-	-	
671	2.5	7260	0.31	2230	390	2	3	-	-	
731	2.3	7260	0.29	2230	390	3	2	-	-	
757	2.2	7260	0.28	2230	390	2	3	-	-	
821	2.1	7260	0.26	2230	390	3	2	-	-	
858	2.0	7260	0.25	2230	390	2	3	-	-	
915	1.9	7260	0.23	2230	390	2	3	-	-	
940	1.8	7260	0.22	2230	390	3	2	-	-	
1047	1.6	7260	0.20	2230	390	2	3	-	-	
1084	1.6	7260	0.19	2230	390	3	2	-	-	
1124	1.5	7260	0.19	2230	390	2	3	-	-	
1218	1.4	7260	0.17	2230	400	3	2	-	-	
1303	1.3	7260	0.16	2230	390	2	3	-	-	
1394	1.2	7260	0.15	2230	390	3	2	-	-	
1430	1.2	7260	0.15	2230	400	2	3	-	-	
1580	1.1	7260	0.13	2230	390	3	2	-	-	
1620	1.0	7260	0.13	2230	400	2	3	-	-	
1728	0.98	7260	0.12	2230	400	2	3	-	-	
1822	0.93	7260	0.12	2230	400	3	2	-	-	
1977	0.86	7260	0.11	2230	400	2	3	-	-	
2070	0.82	7260	0.10	2230	400	3	2	-	-	
2121	0.80	7260	0.10	2230	400	2	3	-	-	
2345	0.72	7260	0.09	2230	400	3	2	-	-	
2460	0.69	7260	0.09	2230	400	2	3	-	-	
2671	0.64	7260	0.08	2230	400	3	3	-	-	
2890	0.59	7260	0.07	2230	400	2	3	-	-	
3053	0.56	7260	0.07	2230	400	3	3	-	-	
3151	0.54	7260	0.07	2230	400	2	3	-	-	
3488	0.49	7260	0.06	2230	400	3	3	-	-	
3999	0.43	7260	0.05	2230	400	3	3	-	-	
4470	0.38	7260	0.05	2230	400	3	3	-	-	

R77R37 AD.. , n_e = 1700 rpm 7260 lb-in

i [ratio]	n _a [rpm]	T _{a max} [lb-in]	P _e [HP]	F _{Ra} ¹⁾ [lb]	F _{Re} [lb]	Stages		φ _(/R) [']		
						Lg	Sm			
5184	0.33	7260	0.04	2230	400	3	3	-	-	R77R37 AD2
5838	0.29	7260	0.04	2230	400	3	3	-	-	
6770	0.25	7260	0.03	2230	400	3	3	-	-	
7617	0.22	7260	0.03	2230	400	3	3	-	-	
8714	0.20	7260	0.02	2230	400	3	3	-	-	
9788	0.17	7260	0.02	2230	400	3	3	-	-	
11021	0.15	7260	0.02	2230	400	3	3	-	-	
12783	0.13	7260	0.02	2230	400	3	3	-	-	
13885	0.12	7260	0.02	2230	400	3	3	-	-	
15015	0.11	7260	0.01	2230	400	3	3	-	-	
16370	0.10	7260	0.01	2230	400	3	3	-	-	

Weight [lbs]	Stages		AD1	AD2
	Large	Small		
R77R37	2	2	94	97
	2	3	95	97
	3	2	97	99
	3	3	97	100

RF77: +13 lbs / RM77: +68 lbs



8.2.12 R87

R87 AD.. , n_e = 1700 rpm 13720 lb-in

i [ratio]	n _a [rpm]	T _{a max} [lb-in]	P _e [HP]	F _{Ra} ¹⁾ [lb]	F _{Re} [lb]	Stages		φ _(/R) [']		
						Lg	Sm			
47.58	36	13720	8.1	2280	210	3	-	7	-	R87 AD2
52.82	32	13720	7.3	2540	220	3	-	6	-	
60.35	28	13720	6.4	2880	220	3	-	6	-	
63.68	27	13720	6.1	3020	230	3	-	6	-	
72.57	23	13720	5.3	3380	230	3	-	6	-	
81.92	21	13720	4.7	3730	300	3	-	6	-	
93.38	18	13720	4.1	3810	300	3	-	6	-	
103.65	16	13720	3.7	3810	310	3	-	6	-	
118.43	14	13720	3.3	3810	310	3	-	6	-	
124.97	14	13720	3.1	3810	310	3	-	6	-	
142.41	12	13720	2.7	3810	320	3	-	6	-	
155.34	11	13720	2.5	3810	320	3	-	6	-	
181.77	9.4	13720	2.1	3810	320	3	-	6	-	
205.71	8.3	13720	1.9	3810	330	3	-	6	-	
216.54	7.9	13720	1.8	3810	330	3	-	6	-	
246.54	6.9	13720	1.6	3810	330	3	-	6	-	
27.84	61	12390	12.4	3190	210	2	-	6	-	R87 AD3
27.88	61	13280	13.4	3130	370	3	-	7	-	
31.40	54	11330	10.0	2210	280	2	-	5	-	
32.66	52	13720	11.9	3320	380	3	-	7	-	
34.40	49	12040	9.7	2150	260	2	-	5	-	
36.84	46	13720	10.5	3490	390	3	-	7	-	
41.74	41	13720	9.3	3680	400	3	-	7	-	
47.58	36	13720	8.1	3810	410	3	-	7	-	
52.82	32	13720	7.3	2540	420	3	-	6	-	
60.35	28	13720	6.4	2880	420	3	-	6	-	
63.68	27	13720	6.1	3020	430	3	-	6	-	
72.57	23	13720	5.3	3380	430	3	-	6	-	
81.92	21	13720	4.7	3730	490	3	-	6	-	
93.38	18	13720	4.1	3810	490	3	-	6	-	

R87 AD.. , n_e = 1700 rpm



13720 lb-in

i [ratio]	n _a [rpm]	T _{a max} [lb-in]	P _e [HP]	F _{Ra} ¹⁾ [lb]	F _{Re} [lb]	Stages		φ (/R) [']			R87	AD3
						Lg	Sm					
103.65	16	13720	3.7	3810	500	3	-	6	-			
118.43	14	13720	3.3	3810	500	3	-	6	-			
124.97	14	13720	3.1	3810	500	3	-	6	-			
142.41	12	13720	2.7	3810	510	3	-	6	-			
155.34	11	13720	2.5	3810	510	3	-	6	-			
181.77	9.4	13720	2.1	3810	510	3	-	6	-			
5.30	321	7430	39	1900	440	2	-	7	M1-6			
6.39	266	8230	36	2000	420	2	-	7	M1-6			
7.13	238	8760	34	2070	400	2	-	7	M1-6			
8.22	207	9380	32	2160	380	2	-	7	M1-6			
9.14	186	9820	30	2230	360	2	-	6	M1-6			
9.90	172	10440	29	2160	610	2	-	6	M1-6			
11.93	142	10890	25	2310	630	2	-	6	M1-6			
13.33	128	11330	24	2390	630	2	-	6	M2			
15.35	111	11860	21	2510	640	2	-	6	-			
17.08	100	12300	20	2600	640	2	-	6	-			
19.10	89	12740	18.5	2700	640	2	-	6	-			
21.51	79	13280	17.2	2810	640	2	-	6	-			
23.40	73	13720	16.3	2880	640	2	-	6	-			
27.84	61	13720	13.7	3110	650	2	-	6	-			
27.88	61	13280	13.4	3130	790	3	-	7	-			
32.66	52	13720	11.9	3320	800	3	-	7	-			
36.84	46	13720	10.5	3490	810	3	-	7	-			
41.74	41	13720	9.3	3680	810	3	-	7	-			
47.58	36	13720	8.1	3810	820	3	-	7	-			
52.82	32	13720	7.3	2540	830	3	-	6	-			
60.35	28	13720	6.4	2880	840	3	-	6	-			
63.68	27	13720	6.1	3020	840	3	-	6	-			
81.92	21	13720	4.7	3730	900	3	-	6	-			
93.38	18	13720	4.1	3810	900	3	-	6	-			
103.65	16	13720	3.7	3810	910	3	-	6	-			
118.43	14	13720	3.3	3810	910	3	-	6	-			
124.97	14	13720	3.1	3810	910	3	-	6	-			
5.30	321	8050	42	1870	1130	2	-	7	M1-6			
6.39	266	9030	39	1960	1110	2	-	7	M1-6			
7.13	238	9470	37	2030	1110	2	-	7	M1-6			
8.22	207	10270	35	2110	1100	2	-	7	M1-6			
9.14	186	10710	33	2190	1090	2	-	6	M1-6			
9.90	172	10440	29	2160	1290	2	-	6	M1-6			
11.93	142	10890	25	2310	1300	2	-	6	M1-6			
13.33	128	11330	24	2390	1300	2	-	6	M2			
15.35	111	11860	21	2510	1310	2	-	6	-			
17.08	100	12300	20	2600	1310	2	-	6	-			
19.10	89	12740	18.5	2700	1310	2	-	6	-			
21.51	79	13280	17.2	2810	1300	2	-	6	-			
27.88	61	13280	13.4	3130	1460	3	-	7	M2			
32.66	52	13720	11.9	3320	1460	3	-	7	-			
36.84	46	13720	10.5	3490	1470	3	-	7	-			
41.74	41	13720	9.3	3680	1480	3	-	7	-			
47.58	36	13720	8.1	3810	1490	3	-	7	-			
81.92	21	13720	4.7	3730	1560	3	-	6	-			
93.38	18	13720	4.1	3810	1570	3	-	6	-			

Weight [lbs]	Stages		AD2	AD3	AD4	AD5
	Large	Small				
R87	2	-	132	141	154	187
	3	-	135	144	157	190

RF87: +15 lbs / RM87: +80 lbs

8.2.13 R87R57

R87R57 AD.. , n _e = 1700 rpm										13720 lb-in	
i [ratio]	n _a [rpm]	T _{a max} [lb-in]	P _e [HP]	F _{Ra} ¹⁾ [lb]	F _{Re} [lb]	Stages		φ _(/R) [']			
						Lg	Sm				
195	8.7	13720	2.0	3810	340	2	2	-	-		
209	8.1	13720	1.9	3810	360	3	2	-	-		
232	7.3	13720	1.7	3810	360	2	2	-	-		
236	7.2	13720	1.7	3810	360	3	2	-	-		
256	6.6	13720	1.5	3810	340	2	2	-	-		
268	6.3	13720	1.5	3810	340	3	2	-	-		
300	5.7	13720	1.3	3810	350	2	2	-	-		
305	5.6	13720	1.3	3810	370	3	2	-	-		
352	4.8	13720	1.1	3810	370	3	2	-	-		
361	4.7	13720	1.1	3810	360	2	2	-	-		
398	4.3	13720	1.0	3810	380	3	2	-	-		
400	4.3	13720	0.98	3810	360	2	2	-	-		
456	3.7	13720	0.88	3810	380	3	2	-	-		
472	3.6	13720	0.83	3810	370	2	2	-	-		
525	3.2	13720	0.76	3810	380	3	2	-	-		
538	3.2	13720	0.73	3810	370	2	2	-	-		
580	2.9	13720	0.69	3810	380	2	3	-	-		
599	2.8	13720	0.67	3810	380	3	2	-	-		
649	2.6	13720	0.61	3810	380	2	3	-	-		
685	2.5	13720	0.58	3810	380	3	2	-	-		
754	2.3	13720	0.53	3810	390	2	3	-	-		
776	2.2	13720	0.51	3810	380	3	2	-	-		
802	2.1	13720	0.50	3810	390	2	3	-	-		
881	1.9	13720	0.46	3810	390	3	3	-	-		
885	1.9	13720	0.45	3810	390	3	2	-	-		
931	1.8	13720	0.43	3810	390	2	3	-	-		
994	1.7	13720	0.41	3810	390	3	3	-	-		
1008	1.7	13720	0.40	3810	390	3	2	-	-		
1037	1.6	13720	0.38	3810	390	2	3	-	-		
1143	1.5	13720	0.35	3810	390	3	2	-	-		
1145	1.5	13720	0.35	3810	390	2	3	-	-		
1232	1.4	13720	0.32	3810	390	2	3	-	-		
1303	1.3	13720	0.31	3810	390	3	2	-	-		
1395	1.2	13720	0.29	3810	390	2	3	-	-		
1489	1.1	13720	0.27	3810	390	2	3	-	-		
1524	1.1	13720	0.26	3810	390	3	2	-	-		
1733	0.98	13720	0.23	3810	390	2	3	-	-		
1737	0.98	13720	0.23	3810	390	3	2	-	-		
1930	0.88	13720	0.21	3810	390	2	3	-	-		
1961	0.87	13720	0.21	3810	390	3	3	-	-		
2129	0.80	13720	0.19	3810	390	2	3	-	-		
2209	0.77	13720	0.18	3810	400	3	3	-	-		
2518	0.68	13720	0.16	3810	400	3	3	-	-		
2595	0.66	13720	0.15	3810	390	2	3	-	-		
2770	0.61	13720	0.14	3810	390	2	3	-	-		
2873	0.59	13720	0.14	3810	400	3	3	-	-		
3182	0.53	13720	0.13	3810	390	2	3	-	-		
3233	0.53	13720	0.13	3810	400	3	3	-	-		
3703	0.46	13720	0.11	3810	390	2	3	-	-		
3744	0.45	13720	0.11	3810	400	3	3	-	-		
4020	0.42	13720	0.10	3810	390	2	3	-	-		
4206	0.40	13720	0.10	3810	400	3	3	-	-		
4831	0.35	13720	0.08	3810	400	3	3	-	-		
5449	0.31	13720	0.07	3810	400	3	3	-	-		
6174	0.28	13720	0.07	3810	400	3	3	-	-		
7038	0.24	13720	0.06	3810	400	3	3	-	-		



R87R57

AD2

8

R87R57 AD.. , n_e = 1700 rpm



13720 lb-in

i [ratio]	n _a [rpm]	T _{a max} [lb-in]	P _e [HP]	F _{Ra} ¹⁾ [lb]	F _{Re} [lb]	Stages		φ _(/R) [']		
						Lg	Sm			
8109	0.21	13720	0.05	3810	400	3	3	-	-	R87R57
9244	0.18	13720	0.04	3810	400	3	3	-	-	
10549	0.16	13720	0.04	3810	400	3	3	-	-	
12025	0.14	13720	0.03	3810	400	3	3	-	-	
13813	0.12	13720	0.03	3810	400	3	3	-	-	
15310	0.11	13720	0.03	3810	400	3	3	-	-	
17452	0.10	13720	0.02	3810	400	3	3	-	-	AD2
195	8.7	13720	2.0	3810	550	2	2	-	-	R87R57
209	8.1	13720	1.9	3810	570	3	2	-	-	
232	7.3	13720	1.7	3810	570	2	2	-	-	
236	7.2	13720	1.7	3810	570	3	2	-	-	
256	6.6	13720	1.5	3810	570	2	2	-	-	
268	6.3	13720	1.5	3810	570	3	2	-	-	
300	5.7	13720	1.3	3810	580	2	2	-	-	
305	5.6	13720	1.3	3810	580	3	2	-	-	
352	4.8	13720	1.1	3810	590	3	2	-	-	
361	4.7	13720	1.1	3810	580	2	2	-	-	
398	4.3	13720	1.0	3810	590	3	2	-	-	
400	4.3	13720	0.98	3810	580	2	2	-	-	
456	3.7	13720	0.88	3810	590	3	2	-	-	
472	3.6	13720	0.83	3810	580	2	2	-	-	
525	3.2	13720	0.76	3810	590	3	2	-	-	
580	2.9	13720	0.69	3810	600	2	3	-	-	
599	2.8	13720	0.67	3810	600	3	2	-	-	
649	2.6	13720	0.61	3810	600	2	3	-	-	
685	2.5	13720	0.58	3810	590	3	2	-	-	
754	2.3	13720	0.53	3810	600	2	3	-	-	
776	2.2	13720	0.51	3810	590	3	2	-	-	
802	2.1	13720	0.50	3810	600	2	3	-	-	
881	1.9	13720	0.46	3810	600	3	3	-	-	
885	1.9	13720	0.45	3810	600	3	2	-	-	
931	1.8	13720	0.43	3810	600	2	3	-	-	
994	1.7	13720	0.41	3810	600	3	3	-	-	
1008	1.7	13720	0.40	3810	600	3	2	-	-	
1037	1.6	13720	0.38	3810	600	2	3	-	-	
1143	1.5	13720	0.35	3810	600	3	2	-	-	
1232	1.4	13720	0.32	3810	600	2	3	-	-	
1303	1.3	13720	0.31	3810	600	3	2	-	-	
1524	1.1	13720	0.26	3810	600	3	2	-	-	
1733	0.98	13720	0.23	3810	600	2	3	-	-	
1737	0.98	13720	0.23	3810	600	3	2	-	-	
1930	0.88	13720	0.21	3810	610	2	3	-	-	
2209	0.77	13720	0.18	3810	610	3	3	-	-	
2518	0.68	13720	0.16	3810	610	3	3	-	-	
2873	0.59	13720	0.14	3810	610	3	3	-	-	
3744	0.45	13720	0.11	3810	610	3	3	-	-	AD3

Weight [lbs]	Stages		AD2	AD3
	Large	Small		
R87R57	2	2	183	190
	2	3	185	192
	3	2	186	193
	3	3	188	195



RF87: +15 lbs / RM87: +80 lbs

8.2.14 R97

R97 AD.. , n _e = 1700 rpm										26550 lb-in	
i [ratio]	n _a [rpm]	T _a max [lb-in]	P _e [HP]	F _{Ra} ¹⁾ [lb]	F _{Re} [lb]	Stages		φ (R) [']			
						Lg	Sm				
53.21	32	26550	14.1	4450	290	3	-	6	-		
59.92	28	26550	12.5	4450	300	3	-	6	-		
65.21	26	26550	11.5	4450	310	3	-	6	-		
72.17	24	26550	10.4	3300	410	3	-	6	-		
83.15	20	26550	9.0	3850	420	3	-	6	-		
92.48	18	26550	8.1	4270	430	3	-	6	-		
103.44	16	26550	7.2	4450	430	3	-	6	-		
116.48	15	26550	6.4	4450	440	3	-	6	-		
126.75	13	26550	5.9	4450	440	3	-	6	-		
150.78	11	26550	5.0	4450	450	3	-	6	-		
170.02	10	26550	4.4	4450	450	3	-	6	-		
186.30	9.1	26550	4.0	4450	450	3	-	6	-		
216.28	7.9	26550	3.5	4450	460	3	-	6	-		
25.03	68	23190	26	3360	320	2	-	5	-		
27.19	63	21510	22	1680	440	2	-	5	-		
27.58	62	23630	24	3490	670	3	-	6	M1-6		
32.05	53	22660	19.7	1800	410	2	-	5	-		
33.25	51	25580	22	3690	680	3	-	6	M2		
37.13	46	26550	20	3830	680	3	-	6	M2		
42.78	40	26550	17.5	4080	700	3	-	6	-		
47.58	36	26550	15.7	4280	710	3	-	6	-		
53.21	32	26550	14.1	4450	720	3	-	6	-		
59.92	28	26550	12.5	4450	730	3	-	6	-		
65.21	26	26550	11.5	4450	740	3	-	6	-		
72.17	24	26550	10.4	3300	830	3	-	6	-		
83.15	20	26550	9.0	3850	840	3	-	6	-		
92.48	18	26550	8.1	4270	840	3	-	6	-		
103.44	16	26550	7.2	4450	850	3	-	6	-		
116.48	15	26550	6.4	4450	850	3	-	6	-		
126.75	13	26550	5.9	4450	860	3	-	6	-		
150.78	11	26550	5.0	4450	860	3	-	6	-		
4.50	378	12210	75	2060	910	2	-	6	M1-6		
5.20	327	14070	75	2100	860	2	-	6	M1-6		
6.21	274	16730	75	2160	690	2	-	6	M1-6		
7.12	239	17700	69	2250	660	2	-	6	M1-6		
8.39	203	17970	60	2410	750	2	-	6	M1-6		
9.29	183	17970	54	2520	800	2	-	6	M1-6		
10.83	157	18500	47	2490	1100	2	-	6	M1-6		
12.39	137	19380	43	2610	1100	2	-	6	M1-6		
14.62	116	20360	39	2760	1110	2	-	6	M1-6		
16.17	105	21240	37	2850	1100	2	-	6	M1-6		
18.24	93	22130	34	2960	1100	2	-	6	M2		
20.14	84	23100	32	3050	1090	2	-	5	-		
22.37	76	24070	30	3150	1080	2	-	5	-		
25.03	68	25050	28	3270	1080	2	-	5	-		
27.58	62	23630	24	3490	1350	3	-	6	M1-6		
33.25	51	25580	22	3690	1350	3	-	6	M2		
37.13	46	26550	20	3830	1350	3	-	6	M2		
42.78	40	26550	17.5	4080	1370	3	-	6	-		
47.58	36	26550	15.7	4280	1380	3	-	6	-		
53.21	32	26550	14.1	4450	1390	3	-	6	-		
59.92	28	26550	12.5	4450	1400	3	-	6	-		
72.17	24	26550	10.4	3300	1500	3	-	6	-		
83.15	20	26550	9.0	3850	1500	3	-	6	-		
92.48	18	26550	8.1	4270	1510	3	-	6	-		
103.44	16	26550	7.2	4450	1510	3	-	6	-		
116.48	15	26550	6.4	4450	1520	3	-	6	-		

8

R97 AD.. , n_e = 1700 rpm 26550 lb-in

i [ratio]	n _a [rpm]	T _{a max} [lb-in]	P _e [HP]	F _{Ra} ¹⁾ [lb]	F _{Re} [lb]	Stages		φ (/R) [']		
						Lg	Sm			
4.50	378	14430	89	1960	1410	2	-	6	M1-6	R97 AD6
5.20	327	15750	84	2030	1400	2	-	6	M1-6	
6.21	274	16730	75	2160	1410	2	-	6	M1-6	
7.12	239	17700	69	2250	1410	2	-	6	M1-6	
8.39	203	17970	60	2410	1450	2	-	6	M1-6	
9.29	183	17970	54	2520	1470	2	-	6	M1-6	
10.83	157	18500	47	2490	1710	2	-	6	M1-6	
12.39	137	19380	43	2610	1710	2	-	6	M1-6	
14.62	116	20360	39	2760	1720	2	-	6	M1-6	
16.17	105	21240	37	2850	1710	2	-	6	M1-6	
18.24	93	22130	34	2960	1710	2	-	6	M2	
20.14	84	23100	32	3050	1700	2	-	5	-	
27.58	62	23630	24	3490	1940	3	-	6	M1-6	
33.25	51	25580	22	3690	1940	3	-	6	M2	
37.13	46	26550	20	3830	1940	3	-	6	-	
42.78	40	26550	17.5	4080	1960	3	-	6	-	
47.58	36	26550	15.7	4280	1970	3	-	6	-	
72.17	24	26550	10.4	3300	2080	3	-	6	-	
83.15	20	26550	9.0	3850	2090	3	-	6	-	
92.48	18	26550	8.1	4270	2090	3	-	6	-	

Weight [lbs]	Stages		AD3	AD4	AD5	AD6
	Large	Small				
R97	2	-	229	240	277	307
	3	-	235	247	284	313

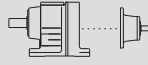

RF97: +40 lbs / RM97: +50 lbs

8.2.15 R97R57

R97R57 AD.. , n _e = 1700 rpm										26550 lb-in	
i [ratio]	n _a [rpm]	T _{a max} [lb-in]	P _e [HP]	F _{Ra} ¹⁾ [lb]	F _{Re} [lb]	Stages		φ _(/R) [']			
						Lg	Sm				
209	8.1	26550	3.7	4450	320	3	2	-	-		
227	7.5	26550	3.4	4450	290	2	2	-	-		
234	7.3	26550	3.3	4450	330	3	2	-	-		
249	6.8	26550	3.1	4450	320	3	2	-	-		
270	6.3	26550	2.8	4450	330	2	2	-	-		
296	5.7	26550	2.6	4450	320	3	2	-	-		
297	5.7	26550	2.6	4450	330	2	2	-	-		
336	5.1	26550	2.3	4450	330	3	2	-	-		
349	4.9	26550	2.2	4450	340	2	2	-	-		
370	4.6	26550	2.1	4450	340	2	2	-	-		
379	4.5	26550	2.0	4450	340	3	2	-	-		
420	4.0	26550	1.8	4450	340	2	2	-	-		
431	3.9	26550	1.8	4450	340	3	2	-	-		
466	3.6	26550	1.6	4450	340	2	2	-	-		
484	3.5	26550	1.6	4450	360	3	2	-	-		
549	3.1	26550	1.4	4450	280	2	2	-	-		
560	3.0	26550	1.4	4450	370	3	2	-	-		
625	2.7	26550	1.2	4450	290	2	2	-	-		
632	2.7	26550	1.2	4450	350	3	2	-	-		
737	2.3	26550	1.0	4450	370	3	2	-	-		
755	2.3	26550	1.0	4450	370	2	3	-	-		
824	2.1	26550	0.94	4450	370	3	2	-	-		
878	1.9	26550	0.88	4450	380	2	3	-	-		
934	1.8	26550	0.83	4450	380	2	3	-	-		
938	1.8	26550	0.82	4450	370	3	2	-	-		
1069	1.6	26550	0.72	4450	370	3	2	-	-		
1084	1.6	26550	0.71	4450	380	2	3	-	-		
1207	1.4	26550	0.64	4450	380	2	3	-	-		
1228	1.4	26550	0.63	4450	380	3	2	-	-	R97R57	AD2
1396	1.2	26550	0.55	4450	380	3	2	-	-		
1434	1.2	26550	0.54	4450	380	2	3	-	-		
1583	1.1	26550	0.49	4450	380	3	2	-	-		
1623	1.0	26550	0.48	4450	380	2	3	-	-		
1733	0.98	26550	0.45	4450	380	2	3	-	-		
1823	0.93	26550	0.42	4450	380	3	2	-	-		
2016	0.84	26550	0.38	4450	390	2	3	-	-		
2078	0.82	26550	0.37	4450	390	3	2	-	-		
2245	0.76	26550	0.34	4450	390	2	3	-	-		
2311	0.74	26550	0.33	4450	390	3	2	-	-		
2668	0.64	26550	0.29	4450	390	2	3	-	-		
2722	0.62	26550	0.28	4450	390	3	2	-	-		
3019	0.56	26550	0.26	4450	390	2	3	-	-		
3065	0.55	26550	0.25	4450	390	3	2	-	-		
3481	0.49	26550	0.23	4450	390	3	3	-	-		
3702	0.46	26550	0.21	4450	390	2	3	-	-		
4004	0.42	26550	0.20	4450	390	3	3	-	-		
4309	0.39	26550	0.18	4450	390	2	3	-	-		
4559	0.37	26550	0.17	4450	390	3	3	-	-		
4678	0.36	26550	0.17	4450	390	2	3	-	-		
5161	0.33	26550	0.15	4450	390	3	3	-	-		
5931	0.29	26550	0.13	4450	400	3	3	-	-		
6708	0.25	26550	0.12	4450	400	3	3	-	-		
7692	0.22	26550	0.10	4450	400	3	3	-	-		
8706	0.20	26550	0.09	4450	400	3	3	-	-		
10030	0.17	26550	0.08	4450	400	3	3	-	-		
11156	0.15	26550	0.07	4450	400	3	3	-	-		
13320	0.13	26550	0.06	4450	400	3	3	-	-		

8

R97R57 AD.. , n_e = 1700 rpm 26550 lb-in

i [ratio]	n _a [rpm]	T _{a max} [lb-in]	P _e [HP]	F _{Ra} ¹⁾ [lb]	F _{Re} [lb]	Stages		φ (/R) [']		
						Lg	Sm			
14999	0.11	26550	0.05	4450	400	3	3	-	-	R97R57
17230	0.10	26550	0.05	4450	400	3	3	-	-	
19332	0.09	26550	0.04	4450	400	3	3	-	-	
21769	0.08	26550	0.04	4450	400	3	3	-	-	
209	8.1	26550	3.7	4450	540	3	2	-	-	R97R57
227	7.5	26550	3.4	4450	510	2	2	-	-	
234	7.3	26550	3.3	4450	540	3	2	-	-	
249	6.8	26550	3.1	4450	540	3	2	-	-	
270	6.3	26550	2.8	4450	540	2	2	-	-	
296	5.7	26550	2.6	4450	540	3	2	-	-	
297	5.7	26550	2.6	4450	550	2	2	-	-	
336	5.1	26550	2.3	4450	540	3	2	-	-	
349	4.9	26550	2.2	4450	550	2	2	-	-	
370	4.6	26550	2.1	4450	550	2	2	-	-	
379	4.5	26550	2.0	4450	550	3	2	-	-	
420	4.0	26550	1.8	4450	550	2	2	-	-	
431	3.9	26550	1.8	4450	560	3	2	-	-	
466	3.6	26550	1.6	4450	560	2	2	-	-	
484	3.5	26550	1.6	4450	570	3	2	-	-	
549	3.1	26550	1.4	4450	560	2	2	-	-	
560	3.0	26550	1.4	4450	580	3	2	-	-	
632	2.7	26550	1.2	4450	580	3	2	-	-	
737	2.3	26550	1.0	4450	580	3	2	-	-	
755	2.3	26550	1.0	4450	590	2	3	-	-	
824	2.1	26550	0.94	4450	590	3	2	-	-	
878	1.9	26550	0.88	4450	590	2	3	-	-	
934	1.8	26550	0.83	4450	590	2	3	-	-	
938	1.8	26550	0.82	4450	580	3	2	-	-	
1084	1.6	26550	0.71	4450	590	2	3	-	-	
1207	1.4	26550	0.64	4450	590	2	3	-	-	
1228	1.4	26550	0.63	4450	590	3	2	-	-	
1396	1.2	26550	0.55	4450	590	3	2	-	-	
1434	1.2	26550	0.54	4450	590	2	3	-	-	
1583	1.1	26550	0.49	4450	590	3	2	-	-	
1823	0.93	26550	0.42	4450	600	3	2	-	-	
2016	0.84	26550	0.38	4450	600	2	3	-	-	
2245	0.76	26550	0.34	4450	600	2	3	-	-	
2668	0.64	26550	0.29	4450	600	2	3	-	-	
3481	0.49	26550	0.23	4450	600	3	3	-	-	
4004	0.42	26550	0.20	4450	610	3	3	-	-	
4559	0.37	26550	0.17	4450	610	3	3	-	-	
7692	0.22	26550	0.10	4450	610	3	3	-	-	

Weight [lbs]	Stages		AD2	AD3
	Large	Small		
R97R57	2	2	273	280
	2	3	275	282
	3	2	279	286
	3	3	281	288

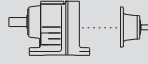

RF97: +40 lbs / RM97: +50 lbs

8.2.16 R107

R107 AD.. , n _e = 1700 rpm										38060 lb-in		
i [ratio]	n _a [rpm]	T _a max [lb-in]	P _e [HP]	F _{Ra} ¹⁾ [lb]	F _{Re} [lb]	Stages		φ (/R) [']				
						Lg	Sm					
72.88	23	38060	14.7	6330	270	3	-	7	-			
78.57	22	38060	13.7	6530	390	3	-	7	-			
92.70	18	38060	11.6	6620	400	3	-	7	-			
102.53	17	38060	10.5	6620	410	3	-	7	-			
115.63	15	38060	9.3	6620	410	3	-	7	-			
127.68	13	38060	8.4	6620	420	3	-	7	-			
141.83	12	38060	7.6	6620	430	3	-	7	-			
158.68	11	38060	6.8	6620	430	3	-	7	-			
172.34	9.9	38060	6.2	6620	430	3	-	7	-			
203.16	8.4	38060	5.3	6620	440	3	-	7	-			
229.95	7.4	38060	4.7	6620	440	3	-	7	-			
251.15	6.8	38060	4.3	6620	440	3	-	7	-			
29.49	58	38060	36	4260	590	3	-	7	M1-6			
30.77	55	29030	26	4730	320	2	-	7	-			
35.26	48	38060	30	4620	620	3	-	7	M1-6			
40.37	42	38060	27	4910	640	3	-	7	M2			
47.63	36	38060	23	5280	670	3	-	7	-			
52.68	32	38060	20	5510	680	3	-	7	-			
59.41	29	38060	18.1	5800	690	3	-	7	-			
65.60	26	38060	16.4	6050	700	3	-	7	-			
72.88	23	38060	14.7	6330	710	3	-	7	-			
78.57	22	38060	13.7	6530	810	3	-	7	-			
92.70	18	38060	11.6	6620	820	3	-	7	-			
102.53	17	38060	10.5	6620	830	3	-	7	-			
115.63	15	38060	9.3	6620	830	3	-	7	-			
127.68	13	38060	8.4	6620	840	3	-	7	-			
141.83	12	38060	7.6	6620	840	3	-	7	-			
158.68	11	38060	6.8	6620	850	3	-	7	-			
172.34	9.9	38060	6.2	6620	850	3	-	7	-			
203.16	8.4	38060	5.3	6620	860	3	-	7	-			
13.66	124	37170	76	2970	680	2	-	7	M1-6			
15.65	109	38060	68	3140	720	2	-	7	M1-6			
18.21	93	38060	58	3390	800	2	-	7	M1-6			
20.07	85	38060	53	3550	850	2	-	7	M1-6			
22.62	75	38060	47	3760	900	2	-	7	M2			
24.90	68	38060	42	3940	920	2	-	7	-			
27.58	62	38060	38	4130	950	2	-	7	-			
29.49	58	38060	36	4260	1270	3	-	7	M1-6			
30.77	55	38060	34	4350	970	2	-	7	-			
35.26	48	38060	30	4620	1300	3	-	7	M1-6			
40.37	42	38060	27	4910	1320	3	-	7	M2			
47.63	36	38060	23	5280	1340	3	-	7	-			
52.68	32	38060	20	5510	1350	3	-	7	-			
59.41	29	38060	18.1	5800	1360	3	-	7	-			
65.60	26	38060	16.4	6050	1370	3	-	7	-			
72.88	23	38060	14.7	6330	1370	3	-	7	-			
78.57	22	38060	13.7	6530	1480	3	-	7	-			
92.70	18	38060	11.6	6620	1490	3	-	7	-			
102.53	17	38060	10.5	6620	1490	3	-	7	-			
115.63	15	38060	9.3	6620	1500	3	-	7	-			
127.68	13	38060	8.4	6620	1500	3	-	7	-			
141.83	12	38060	7.6	6620	1510	3	-	7	-			
158.68	11	38060	6.8	6620	1510	3	-	7	-			

8

R107 AD.. , n_e = 1700 rpm 38060 lb-in



i [ratio]	n _a [rpm]	T _{a max} [lb-in]	P _e [HP]	F _{Ra} ¹⁾ [lb]	F _{Re} [lb]	Stages		φ (/R) [']		
						Lg	Sm			
4.92	346	17700	100	2600	1410	2	-	9	M1-6	R107 AD6
5.82	292	19030	91	2740	1410	2	-	9	M1-6	
6.66	255	21770	91	2800	1350	2	-	9	M1-6	
7.86	216	25670	91	2860	1140	2	-	9	M1-6	
8.56	199	27970	91	2710	1490	2	-	7	M1-6	
10.13	168	33100	91	2710	1410	2	-	7	M1-6	
11.59	147	37880	91	2700	1350	2	-	7	M1-6	
13.66	124	38060	77	2930	1400	2	-	7	M1-6	
15.65	109	38060	68	3140	1440	2	-	7	M1-6	
18.21	93	38060	58	3390	1480	2	-	7	M1-6	
20.07	85	38060	53	3550	1500	2	-	7	M1-6	
22.62	75	38060	47	3760	1520	2	-	7	M2	
24.90	68	38060	42	3940	1540	2	-	7	-	
29.49	58	38060	36	4260	1870	3	-	7	M1-6	
35.26	48	38060	30	4620	1900	3	-	7	M1-6	
40.37	42	38060	27	4910	1910	3	-	7	M2	
47.63	36	38060	23	5280	1930	3	-	7	-	
52.68	32	38060	20	5510	1940	3	-	7	-	
59.41	29	38060	18.1	5800	1950	3	-	7	-	
65.60	26	38060	16.4	6050	1960	3	-	7	-	
78.57	22	38060	13.7	6530	2060	3	-	7	-	
92.70	18	38060	11.6	6620	2070	3	-	7	-	
102.53	17	38060	10.5	6620	2080	3	-	7	-	
115.63	15	38060	9.3	6620	2080	3	-	7	-	
127.68	13	38060	8.4	6620	2090	3	-	7	-	

Weight [lbs]	Stages		AD3	AD4	AD5	AD6
	Large	Small				
R107	2	-	349	363	393	423
	3	-	363	377	407	437
RF107: +10 lbs / RM107: +205 lbs						

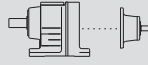

8.2.17 R107R77

R107R77 AD.. , n _e = 1700 rpm										38060 lb-in	
i [ratio]	n _a [rpm]	T _{a max} [lb-in]	P _e [HP]	F _{Ra} ¹⁾ [lb]	F _{Re} [lb]	Stages		φ _(/R) [']			
						Lg	Sm				
172	9.9	38060	6.3	6620	240	2	2	-	-		
187	9.1	38060	5.9	6620	290	3	2	-	-		
193	8.8	38060	5.7	6620	290	2	2	-	-		
214	7.9	38060	5.2	6620	300	3	2	-	-		
220	7.7	38060	5.0	6620	280	2	2	-	-		
253	6.7	38060	4.4	6620	320	3	2	-	-		
256	6.6	38060	4.3	6620	300	2	2	-	-		
284	6.0	38060	3.8	6620	300	2	2	-	-		
285	6.0	38060	3.9	6620	320	3	2	-	-		
323	5.3	38060	3.4	6620	320	3	2	-	-		
325	5.2	38060	3.4	6620	310	2	2	-	-		
369	4.6	38060	3.0	6620	330	3	2	-	-		
377	4.5	38060	2.9	6620	320	2	2	-	-		
417	4.1	38060	2.7	6620	350	3	2	-	-		
426	4.0	38060	2.6	6620	310	2	2	-	-		
469	3.6	38060	2.3	6620	320	2	2	-	-		
492	3.5	38060	2.3	6620	360	3	2	-	-		
528	3.2	38060	2.1	6620	360	2	3	-	-		
544	3.1	38060	2.0	6620	360	3	2	-	-		
614	2.8	38060	1.8	6620	360	3	2	-	-		
626	2.7	38060	1.8	6620	350	2	3	-	-		
717	2.4	38060	1.5	6620	320	2	3	-	-		
815	2.1	38060	1.4	6620	320	2	3	-	-		
822	2.1	38060	1.3	6620	360	3	2	-	-		
919	1.8	38060	1.2	6620	360	2	3	-	-		
939	1.8	38060	1.2	6620	360	3	2	-	-		
1055	1.6	38060	1.0	6620	370	2	3	-	-		
1104	1.5	38060	1.0	6620	380	3	2	-	-		
1209	1.4	38060	0.92	6620	380	2	3	-	-	R107R77	AD2
1226	1.4	38060	0.90	6620	380	3	2	-	-		
1400	1.2	38060	0.79	6620	380	3	2	-	-		
1407	1.2	38060	0.79	6620	380	2	3	-	-		
1550	1.1	38060	0.71	6620	380	2	3	-	-		
1599	1.1	38060	0.69	6620	380	3	2	-	-		
1693	1.0	38060	0.65	6620	380	2	3	-	-		
1827	0.93	38060	0.61	6620	380	3	2	-	-		
1987	0.86	38060	0.56	6620	380	3	2	-	-		
2067	0.82	38060	0.54	6620	380	2	3	-	-		
2280	0.75	38060	0.49	6620	380	2	3	-	-		
2339	0.73	38060	0.48	6620	390	3	3	-	-		
2653	0.64	38060	0.42	6620	380	2	3	-	-		
2688	0.63	38060	0.42	6620	390	3	3	-	-		
3034	0.56	38060	0.36	6620	380	2	3	-	-		
3039	0.56	38060	0.37	6620	390	3	3	-	-		
3343	0.51	38060	0.33	6620	390	2	3	-	-		
3432	0.50	38060	0.33	6620	390	3	3	-	-		
3896	0.44	38060	0.29	6620	390	3	3	-	-		
3918	0.43	38060	0.28	6620	390	2	3	-	-		
4435	0.38	38060	0.25	6620	390	3	3	-	-		
5168	0.33	38060	0.22	6620	400	3	3	-	-		
5914	0.29	38060	0.19	6620	390	3	3	-	-		
6743	0.25	38060	0.17	6620	400	3	3	-	-		
7583	0.22	38060	0.15	6620	400	3	3	-	-		
8618	0.20	38060	0.13	6620	400	3	3	-	-		
9547	0.18	38060	0.12	6620	400	3	3	-	-		
11256	0.15	38060	0.10	6620	400	3	3	-	-		
12829	0.13	38060	0.09	6620	400	3	3	-	-		

8

R107R77 AD.. , n _e = 1700 rpm										38060 lb-in	
i [ratio]	n _a [rpm]	T _{a max} [lb-in]	P _e [HP]	F _{Ra} ¹⁾ [lb]	F _{Re} [lb]	Stages		φ _(/R) [']			
						Lg	Sm				
14936	0.11	38060	0.08	6620	400	3	3	-	-	R107R77	AD2
17080	0.10	38060	0.07	6620	400	3	3	-	-		
20018	0.08	38060	0.06	6620	400	3	3	-	-		
172	9.9	38060	6.3	6620	460	2	2	-	-	R107R77	AD3
187	9.1	38060	5.9	6620	500	3	2	-	-		
193	8.8	38060	5.7	6620	510	2	2	-	-		
214	7.9	38060	5.2	6620	520	3	2	-	-		
220	7.7	38060	5.0	6620	500	2	2	-	-		
253	6.7	38060	4.4	6620	530	3	2	-	-		
256	6.6	38060	4.3	6620	510	2	2	-	-		
284	6.0	38060	3.8	6620	520	2	2	-	-		
285	6.0	38060	3.9	6620	530	3	2	-	-		
323	5.3	38060	3.4	6620	540	3	2	-	-		
325	5.2	38060	3.4	6620	520	2	2	-	-		
369	4.6	38060	3.0	6620	540	3	2	-	-		
377	4.5	38060	2.9	6620	530	2	2	-	-		
417	4.1	38060	2.7	6620	560	3	2	-	-		
426	4.0	38060	2.6	6620	530	2	2	-	-		
469	3.6	38060	2.3	6620	540	2	2	-	-		
492	3.5	38060	2.3	6620	570	3	2	-	-		
528	3.2	38060	2.1	6620	570	2	3	-	-		
544	3.1	38060	2.0	6620	570	3	2	-	-		
614	2.8	38060	1.8	6620	580	3	2	-	-		
626	2.7	38060	1.8	6620	560	2	3	-	-		
717	2.4	38060	1.5	6620	570	2	3	-	-		
815	2.1	38060	1.4	6620	570	2	3	-	-		
822	2.1	38060	1.3	6620	580	3	2	-	-		
919	1.8	38060	1.2	6620	580	2	3	-	-		
939	1.8	38060	1.2	6620	580	3	2	-	-		
1055	1.6	38060	1.0	6620	580	2	3	-	-		
1104	1.5	38060	1.0	6620	590	3	2	-	-		
1209	1.4	38060	0.92	6620	590	2	3	-	-		
1226	1.4	38060	0.90	6620	590	3	2	-	-		
1400	1.2	38060	0.79	6620	590	3	2	-	-		
1407	1.2	38060	0.79	6620	590	2	3	-	-		
1550	1.1	38060	0.71	6620	590	2	3	-	-		
1599	1.1	38060	0.69	6620	600	3	2	-	-		
1693	1.0	38060	0.65	6620	590	2	3	-	-		
1827	0.93	38060	0.61	6620	600	3	2	-	-		
1987	0.86	38060	0.56	6620	600	3	2	-	-		
2067	0.82	38060	0.54	6620	600	2	3	-	-		
2339	0.73	38060	0.48	6620	600	3	3	-	-		
2688	0.63	38060	0.42	6620	600	3	3	-	-		
3039	0.56	38060	0.37	6620	600	3	3	-	-		
3432	0.50	38060	0.33	6620	600	3	3	-	-		
3896	0.44	38060	0.29	6620	600	3	3	-	-		
4435	0.38	38060	0.25	6620	610	3	3	-	-		
5168	0.33	38060	0.22	6620	610	3	3	-	-		
5914	0.29	38060	0.19	6620	610	3	3	-	-		
6743	0.25	38060	0.17	6620	610	3	3	-	-		
7583	0.22	38060	0.15	6620	610	3	3	-	-		
8618	0.20	38060	0.13	6620	610	3	3	-	-		
9547	0.18	38060	0.12	6620	610	3	3	-	-		
11256	0.15	38060	0.10	6620	610	3	3	-	-		

R107R77 AD.. , n_e = 1700 rpm 38060 lb-in

i [ratio]	n _a [rpm]	T _a max [lb-in]	P _e [HP]	F _{Ra} ¹⁾ [lb]	F _{Re} [lb]	Stages		φ _(/R) [']		
						Lg	Sm			
172	9.9	38060	6.3	6620	850	2	2	-	-	R107R77 AD4
187	9.1	38060	5.9	6620	890	3	2	-	-	
193	8.8	38060	5.7	6620	890	2	2	-	-	
214	7.9	38060	5.2	6620	900	3	2	-	-	
220	7.7	38060	5.0	6620	890	2	2	-	-	
253	6.7	38060	4.4	6620	920	3	2	-	-	
256	6.6	38060	4.3	6620	900	2	2	-	-	
284	6.0	38060	3.8	6620	910	2	2	-	-	
285	6.0	38060	3.9	6620	920	3	2	-	-	
323	5.3	38060	3.4	6620	920	3	2	-	-	
325	5.2	38060	3.4	6620	910	2	2	-	-	
369	4.6	38060	3.0	6620	930	3	2	-	-	
377	4.5	38060	2.9	6620	920	2	2	-	-	
417	4.1	38060	2.7	6620	940	3	2	-	-	
492	3.5	38060	2.3	6620	950	3	2	-	-	
528	3.2	38060	2.1	6620	950	2	3	-	-	
544	3.1	38060	2.0	6620	950	3	2	-	-	
614	2.8	38060	1.8	6620	950	3	2	-	-	
626	2.7	38060	1.8	6620	950	2	3	-	-	
717	2.4	38060	1.5	6620	950	2	3	-	-	
822	2.1	38060	1.3	6620	960	3	2	-	-	
919	1.8	38060	1.2	6620	960	2	3	-	-	
939	1.8	38060	1.2	6620	960	3	2	-	-	
1055	1.6	38060	1.0	6620	960	2	3	-	-	
1104	1.5	38060	1.0	6620	970	3	2	-	-	
1209	1.4	38060	0.92	6620	970	2	3	-	-	
1226	1.4	38060	0.90	6620	970	3	2	-	-	
1400	1.2	38060	0.79	6620	970	3	2	-	-	
1407	1.2	38060	0.79	6620	970	2	3	-	-	
1550	1.1	38060	0.71	6620	970	2	3	-	-	
1599	1.1	38060	0.69	6620	970	3	2	-	-	
1827	0.93	38060	0.61	6620	970	3	2	-	-	
2339	0.73	38060	0.48	6620	980	3	3	-	-	
2688	0.63	38060	0.42	6620	980	3	3	-	-	
3432	0.50	38060	0.33	6620	980	3	3	-	-	
3896	0.44	38060	0.29	6620	980	3	3	-	-	
4435	0.38	38060	0.25	6620	980	3	3	-	-	
5168	0.33	38060	0.22	6620	980	3	3	-	-	
6743	0.25	38060	0.17	6620	980	3	3	-	-	
7583	0.22	38060	0.15	6620	980	3	3	-	-	



Weight [lbs]	Stages		AD2	AD3	AD4
	Large	Small			
R107R77	2	2	424	432	445
	2	3	427	434	448
	3	2	439	446	459
	3	3	441	448	462

RF107: +10 lbs / RM107: +205 lbs

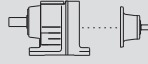
8.2.18 R137

R137 AD.. , n _e = 1700 rpm										70800 lb-in		
i [ratio]	n _a [rpm]	T _a max [lb-in]	P _e [HP]	F _{RA} ¹⁾ [lb]	F _{Re} [lb]	Stages		φ (/R) [']			R137	AD4
						Lg	Sm					
50.86	33	69740	39	12060	450	3	-	6	M2,4			
59.17	29	70800	34	12000	490	3	-	6	M2			
65.20	26	70800	31	12000	520	3	-	6	-			
73.49	23	70800	27	12000	540	3	-	6	-			
80.91	21	70800	25	12000	560	3	-	6	-			
88.70	19	70800	23	12000	700	3	-	6	-			
103.20	16	70800	19.4	12000	710	3	-	6	-			
113.72	15	70800	17.6	12000	720	3	-	6	-			
128.18	13	70800	15.6	12000	730	3	-	6	-			
141.12	12	70800	14.2	12000	740	3	-	6	-			
156.31	11	70800	12.8	12000	750	3	-	6	-			
174.40	9.7	70800	11.5	12000	760	3	-	6	-			
188.45	9.0	70800	10.6	12000	760	3	-	6	-			
222.60	7.6	70800	9.0	12000	770	3	-	6	-			
27.83	61	67970	69	11130	1050	3	-	7	M1-6			
29.57	57	57610	54	12640	490	2	-	6	-			
32.91	52	70800	61	11780	1070	3	-	6	M1-6			
37.65	45	70800	53	12000	1100	3	-	6	M1-6			
44.39	38	70800	45	12000	1140	3	-	6	M1-6			
50.86	33	70800	39	12000	1160	3	-	6	M2,4			
59.17	29	70800	34	12000	1190	3	-	6	M2			
65.20	26	70800	31	12000	1200	3	-	6	-			
73.49	23	70800	27	12000	1220	3	-	6	-			
80.91	21	70800	25	12000	1230	3	-	6	-			
88.70	19	70800	23	12000	1370	3	-	6	-			
103.20	16	70800	19.4	12000	1380	3	-	6	-			
113.72	15	70800	17.6	12000	1390	3	-	6	-			
128.18	13	70800	15.6	12000	1400	3	-	6	-			
141.12	12	70800	14.2	12000	1410	3	-	6	-			
156.31	11	70800	12.8	12000	1420	3	-	6	-			
174.40	9.7	70800	11.5	12000	1420	3	-	6	-			
22.00	77	70270	89	9580	670	2	-	6	M1-6			
24.12	70	70800	82	10020	710	2	-	6	M1-6			
27.83	61	67970	69	11130	1670	3	-	7	M1-6			
29.57	57	68850	65	11380	900	2	-	6	M2			
32.91	52	70800	61	11780	1680	3	-	6	M1-6			
37.65	45	70800	53	12000	1710	3	-	6	M1-6			
44.39	38	70800	45	12000	1750	3	-	6	M1-6			
50.86	33	70800	39	12000	1770	3	-	6	M2,4			
59.17	29	70800	34	12000	1790	3	-	6	M2			
65.20	26	70800	31	12000	1800	3	-	6	-			
73.49	23	70800	27	12000	1820	3	-	6	-			
80.91	21	70800	25	12000	1830	3	-	6	-			
88.70	19	70800	23	12000	1960	3	-	6	-			
103.20	16	70800	19.4	12000	1980	3	-	6	-			
113.72	15	70800	17.6	12000	1980	3	-	6	-			
128.18	13	70800	15.6	12000	1990	3	-	6	-			
141.12	12	70800	14.2	12000	2000	3	-	6	-			

R137 AD.. , n_e = 1700 rpm 70800 lb-in

i [ratio]	n _a [rpm]	T _{a max} [lb-in]	P _e [HP]	F _{Ra} ¹⁾ [lb]	F _{Re} [lb]	Stages		φ (/R) [']		
						Lg	Sm			
5.15	330	36290	196	7540	1200	2	-	8	M1-6	R137 AD7
6.38	266	38940	170	8020	1320	2	-	8	M1-6	
7.59	224	40710	149	8480	1430	2	-	8	M1-6	
8.71	195	61070	195	6360	1230	2	-	6	M1-6	
10.79	158	63720	164	6940	1520	2	-	6	M1-6	
12.83	133	65400	142	7510	1750	2	-	6	M1-6	
14.51	117	70800	136	7450	1510	2	-	6	M1-6	
16.80	101	70800	117	8150	1770	2	-	6	M1-6	
19.04	89	70800	103	8770	1940	2	-	6	M1-6	
22.00	77	70800	89	9520	2170	2	-	6	M1-6	
24.12	70	70800	82	10020	2280	2	-	6	M1-6	
27.83	61	67970	69	11130	3780	3	-	7	M1-6	
32.91	52	70800	61	11780	3790	3	-	6	M1-6	
37.65	45	70800	53	12000	3820	3	-	6	M1-6	
44.39	38	70800	45	12000	3850	3	-	6	M1-6	
50.86	33	70800	39	12000	3870	3	-	6	M2,4	
59.17	29	70800	34	12000	3890	3	-	6	-	
65.20	26	70800	31	12000	3900	3	-	6	-	
88.70	19	70800	23	12000	4040	3	-	6	-	
103.20	16	70800	19.4	12000	4050	3	-	6	-	
113.72	15	70800	17.6	12000	4060	3	-	6	-	

Weight [lbs]	Stages		AD4	AD5	AD6	AD7
	Large	Small				
R137	2	-	544	570	600	619
	3	-	566	592	622	641

RF137: +50 lbs / RM137: +290 lbs

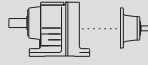

8.2.19 R137R77

R137R77 AD.. , n _e = 1700 rpm										70800 lb-in	
i [ratio]	n _a [rpm]	T _a max [lb-in]	P _e [HP]	F _{Ra} ¹⁾ [lb]	F _{Re} [lb]	Stages		φ _(/R) [']			
						Lg	Sm				
255	6.7	70800	8.1	12000	210	3	2	-	-		
291	5.8	70800	7.1	12000	230	3	2	-	-		
297	5.7	70800	6.8	12000	250	2	2	-	-		
323	5.3	70800	6.4	12000	240	3	2	-	-		
339	5.0	70800	6.0	12000	260	2	2	-	-		
376	4.5	70800	5.4	12000	260	2	2	-	-		
381	4.5	70800	5.4	12000	260	3	2	-	-		
428	4.0	70800	4.8	12000	310	3	2	-	-		
453	3.8	70800	4.5	12000	270	2	2	-	-		
490	3.5	70800	4.2	12000	320	3	2	-	-		
517	3.3	70800	3.9	12000	280	2	2	-	-		
560	3.0	70800	3.7	12000	310	3	2	-	-		
564	3.0	70800	3.6	12000	280	2	2	-	-		
609	2.8	70800	3.4	12000	330	2	3	-	-		
629	2.7	70800	3.3	12000	340	3	2	-	-		
699	2.4	70800	2.9	12000	340	2	3	-	-		
730	2.3	70800	2.8	12000	340	3	2	-	-		
831	2.0	70800	2.5	12000	340	3	2	-	-		
888	1.9	70800	2.3	12000	340	2	3	-	-		
951	1.8	70800	2.2	12000	330	3	2	-	-		
1043	1.6	70800	2.0	12000	350	2	3	-	-		
1090	1.6	70800	1.9	12000	340	3	2	-	-		
1105	1.5	70800	1.9	12000	350	2	3	-	-		
1226	1.4	70800	1.7	12000	350	3	2	-	-		
1256	1.4	70800	1.6	12000	350	2	3	-	-		
1391	1.2	70800	1.5	12000	290	2	3	-	-		
1397	1.2	70800	1.5	12000	310	3	2	-	-		
1586	1.1	70800	1.3	12000	370	2	3	-	-		
1598	1.1	70800	1.3	12000	370	3	2	-	-		
1839	0.92	70800	1.1	12000	370	3	2	-	-		
1863	0.91	70800	1.1	12000	370	2	3	-	-		
2073	0.82	70800	0.99	12000	360	3	2	-	-		
2242	0.76	70800	0.92	12000	370	2	3	-	-		
2412	0.70	70800	0.85	12000	370	3	2	-	-		
2484	0.68	70800	0.83	12000	370	2	3	-	-		
2658	0.64	70800	0.77	12000	370	3	2	-	-		
2929	0.58	70800	0.70	12000	370	2	3	-	-		
2993	0.57	70800	0.70	12000	390	3	3	-	-		
3338	0.51	70800	0.62	12000	380	2	3	-	-		
3454	0.49	70800	0.61	12000	390	3	3	-	-		
3514	0.48	70800	0.59	12000	380	2	3	-	-		
3928	0.43	70800	0.53	12000	390	3	3	-	-		
4018	0.42	70800	0.51	12000	380	2	3	-	-		
4464	0.38	70800	0.47	12000	390	3	3	-	-		
4709	0.36	70800	0.44	12000	380	2	3	-	-		
5116	0.33	70800	0.41	12000	390	3	3	-	-		
5834	0.29	70800	0.36	12000	390	3	3	-	-		
6559	0.26	70800	0.32	12000	390	3	3	-	-		
7479	0.23	70800	0.28	12000	390	3	3	-	-		
8784	0.19	70800	0.24	12000	390	3	3	-	-		
10573	0.16	70800	0.20	12000	390	3	3	-	-		
11712	0.15	70800	0.18	12000	390	3	3	-	-		
12921	0.13	70800	0.16	12000	390	3	3	-	-		
14777	0.12	70800	0.14	12000	390	3	3	-	-		
16566	0.10	70800	0.13	12000	400	3	3	-	-		
18945	0.09	70800	0.11	12000	400	3	3	-	-		
22203	0.08	70800	0.09	12000	400	3	3	-	-		

R137R77

AD2

R137R77 AD.. , n_e = 1700 rpm 70800 lb-in



i [ratio]	n _a [rpm]	T _{a max} [lb-in]	P _e [HP]	F _{Ra} ¹⁾ [lb]	F _{Re} [lb]	Stages		φ _(/R) [']		
						Lg	Sm			
175	9.7	70800	11.8	12000	390	3	2	-	-	
197	8.6	70800	10.5	12000	400	3	2	-	-	
223	7.6	70800	9.2	12000	410	3	2	-	-	
255	6.7	70800	8.1	12000	420	3	2	-	-	
291	5.8	70800	7.1	12000	450	3	2	-	-	
297	5.7	70800	6.8	12000	470	2	2	-	-	
323	5.3	70800	6.4	12000	460	3	2	-	-	
339	5.0	70800	6.0	12000	470	2	2	-	-	
376	4.5	70800	5.4	12000	480	2	2	-	-	
381	4.5	70800	5.4	12000	480	3	2	-	-	
428	4.0	70800	4.8	12000	520	3	2	-	-	
453	3.8	70800	4.5	12000	490	2	2	-	-	
490	3.5	70800	4.2	12000	530	3	2	-	-	
517	3.3	70800	3.9	12000	490	2	2	-	-	
560	3.0	70800	3.7	12000	520	3	2	-	-	
564	3.0	70800	3.6	12000	490	2	2	-	-	
609	2.8	70800	3.4	12000	550	2	3	-	-	
629	2.7	70800	3.3	12000	550	3	2	-	-	
699	2.4	70800	2.9	12000	550	2	3	-	-	
730	2.3	70800	2.8	12000	550	3	2	-	-	
831	2.0	70800	2.5	12000	550	3	2	-	-	
888	1.9	70800	2.3	12000	560	2	3	-	-	
951	1.8	70800	2.2	12000	550	3	2	-	-	
1043	1.6	70800	2.0	12000	560	2	3	-	-	
1090	1.6	70800	1.9	12000	550	3	2	-	-	
1105	1.5	70800	1.9	12000	560	2	3	-	-	
1226	1.4	70800	1.7	12000	570	3	2	-	-	
1256	1.4	70800	1.6	12000	560	2	3	-	-	
1391	1.2	70800	1.5	12000	570	2	3	-	-	
1397	1.2	70800	1.5	12000	570	3	2	-	-	
1586	1.1	70800	1.3	12000	580	2	3	-	-	
1598	1.1	70800	1.3	12000	580	3	2	-	-	
1839	0.92	70800	1.1	12000	580	3	2	-	-	
1863	0.91	70800	1.1	12000	580	2	3	-	-	
2073	0.82	70800	0.99	12000	580	3	2	-	-	
2242	0.76	70800	0.92	12000	580	2	3	-	-	
2412	0.70	70800	0.85	12000	580	3	2	-	-	
2484	0.68	70800	0.83	12000	590	2	3	-	-	
2658	0.64	70800	0.77	12000	590	3	2	-	-	
2929	0.58	70800	0.70	12000	590	2	3	-	-	
2993	0.57	70800	0.70	12000	600	3	3	-	-	
3454	0.49	70800	0.61	12000	600	3	3	-	-	
3928	0.43	70800	0.53	12000	600	3	3	-	-	
4464	0.38	70800	0.47	12000	600	3	3	-	-	
5116	0.33	70800	0.41	12000	600	3	3	-	-	
5834	0.29	70800	0.36	12000	600	3	3	-	-	
6559	0.26	70800	0.32	12000	600	3	3	-	-	
7479	0.23	70800	0.28	12000	610	3	3	-	-	
8784	0.19	70800	0.24	12000	610	3	3	-	-	
10573	0.16	70800	0.20	12000	610	3	3	-	-	
11712	0.15	70800	0.18	12000	610	3	3	-	-	
175	9.7	70800	11.8	12000	800	3	2	-	-	
197	8.6	70800	10.5	12000	810	3	2	-	-	
223	7.6	70800	9.2	12000	810	3	2	-	-	
255	6.7	70800	8.1	12000	820	3	2	-	-	
291	5.8	70800	7.1	12000	840	3	2	-	-	
297	5.7	70800	6.8	12000	860	2	2	-	-	
323	5.3	70800	6.4	12000	850	3	2	-	-	

8

R137R77 AD3

R137R77 AD4

R137R77 AD.. , n_e = 1700 rpm 70800 lb-in

i [ratio]	n _a [rpm]	T _{a max} [lb-in]	P _e [HP]	F _{Ra} ¹⁾ [lb]	F _{Re} [lb]	Stages		φ _(/R) [']		
						Lg	Sm			
339	5.0	70800	6.0	12000	860	2	2	-	-	R137R77 AD4
376	4.5	70800	5.4	12000	870	2	2	-	-	
381	4.5	70800	5.4	12000	870	3	2	-	-	
428	4.0	70800	4.8	12000	910	3	2	-	-	
453	3.8	70800	4.5	12000	880	2	2	-	-	
490	3.5	70800	4.2	12000	920	3	2	-	-	
560	3.0	70800	3.7	12000	910	3	2	-	-	
609	2.8	70800	3.4	12000	930	2	3	-	-	
629	2.7	70800	3.3	12000	930	3	2	-	-	
699	2.4	70800	2.9	12000	930	2	3	-	-	
730	2.3	70800	2.8	12000	930	3	2	-	-	
831	2.0	70800	2.5	12000	940	3	2	-	-	
888	1.9	70800	2.3	12000	940	2	3	-	-	
1043	1.6	70800	2.0	12000	940	2	3	-	-	
1105	1.5	70800	1.9	12000	940	2	3	-	-	
1226	1.4	70800	1.7	12000	950	3	2	-	-	
1586	1.1	70800	1.3	12000	960	2	3	-	-	
1598	1.1	70800	1.3	12000	960	3	2	-	-	
1839	0.92	70800	1.1	12000	960	3	2	-	-	
1863	0.91	70800	1.1	12000	960	2	3	-	-	
2993	0.57	70800	0.70	12000	970	3	3	-	-	
3454	0.49	70800	0.61	12000	970	3	3	-	-	
3928	0.43	70800	0.53	12000	980	3	3	-	-	
4464	0.38	70800	0.47	12000	980	3	3	-	-	
5834	0.29	70800	0.36	12000	980	3	3	-	-	
7479	0.23	70800	0.28	12000	980	3	3	-	-	
8784	0.19	70800	0.24	12000	980	3	3	-	-	

Weight [lbs]	Stages		AD2	AD3	AD4
	Large	Small			
R137R77	2	2	607	614	628
	2	3	610	617	630
	3	2	629	636	650
	3	3	632	639	652
RF137: +50 lbs / RM137: +290 lbs					

8.2.20 R147

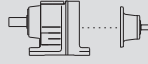
R147 AD.. , n _e = 1700 rpm										115050 lb-in					
i [ratio]	n _a [rpm]	T _a max [lb-in]	P _e [HP]	F _{Ra} ¹⁾ [lb]	F _{Re} [lb]	Stages		φ (/R) [']							
						Lg	Sm								
83.47	20	115050	39	14090	510	3	-	6	M2	R147	AD4				
94.60	18	115050	34	14090	520	3	-	6	-						
109.31	16	115050	30	14090	550	3	-	5	-						
119.86	14	115050	27	14090	560	3	-	5	-						
146.91	12	115050	22	14090	590	3	-	5	-						
163.31	10	115050	19.9	14090	600	3	-	5	-						
46.65	36	115050	70	14090	810	3	-	6	M1-6	R147	AD5				
52.87	32	115050	61	14090	860	3	-	6	M1-6						
61.09	28	115050	53	14090	890	3	-	6	M2						
66.99	25	115050	48	14090	910	3	-	6	-						
72.09	24	115050	45	14090	1160	3	-	6	M2,4						
83.47	20	115050	39	14090	1190	3	-	6	M2						
94.60	18	115050	34	14090	1210	3	-	6	-						
109.31	16	115050	30	14090	1230	3	-	5	-						
119.86	14	115050	27	14090	1240	3	-	5	-						
146.91	12	115050	22	14090	1260	3	-	5	-						
163.31	10	115050	19.9	14090	1270	3	-	5	-						
35.64	48	114170	90	14130	1380	3	-	6	M1-6				R147	AD6	
40.29	42	115050	81	14090	1420	3	-	6	M1-6						
46.65	36	115050	70	14090	1460	3	-	6	M1-6						
52.87	32	115050	61	14090	1480	3	-	6	M1-6						
61.09	28	115050	53	14090	1520	3	-	6	M2						
66.99	25	115050	48	14090	1530	3	-	6	-						
72.09	24	115050	45	14090	1770	3	-	6	M2,4						
83.47	20	115050	39	14090	1790	3	-	6	M2						
94.60	18	115050	34	14090	1810	3	-	6	-						
109.31	16	115050	30	14090	1830	3	-	5	-						
119.86	14	115050	27	14090	1840	3	-	5	-						
146.91	12	115050	22	14090	1860	3	-	5	-						
24.19	70	105320	123	14550	3460	3	-	6	M1-6	R147	AD7				
29.95	57	115050	108	14090	3470	3	-	6	M1-6						
35.64	48	115050	91	14090	3530	3	-	6	M1-6						
40.29	42	115050	81	14090	3570	3	-	6	M1-6						
46.65	36	115050	70	14090	3600	3	-	6	M1-6						
52.87	32	115050	61	14090	3630	3	-	6	M1-6						
61.09	28	115050	53	14090	3660	3	-	6	M2						
66.99	25	115050	48	14090	3670	3	-	6	-						
72.09	24	115050	45	14090	3870	3	-	6	M2,4						
83.47	20	115050	39	14090	3890	3	-	6	M2						
94.60	18	115050	34	14090	3900	3	-	6	-						
109.31	16	115050	30	14090	3920	3	-	5	-						
119.86	14	115050	27	14090	3930	3	-	5	-						
5.00	340	39210	218	13100	5110	2	-	8	M1-6				R147	AD8	
5.89	289	46290	218	13360	5000	2	-	8	M1-6						
7.25	234	56990	219	13600	4830	2	-	8	M1-6						
8.26	206	64960	219	13900	5110	2	-	6	M1-6						
9.74	175	76550	218	13970	5000	2	-	6	M1-6						
11.99	142	93810	218	13930	4840	2	-	5	M1-6						
13.91	122	108860	218	13750	4670	2	-	5	M1-6						
15.64	109	115050	205	14060	4650	2	-	5	M1-6						
18.04	94	91160	140	15140	5070	2	-	5	M1-6						
20.44	83	103550	141	14630	4940	2	-	5	M1-6						
24.19	70	105320	123	14550	5580	3	-	6	M1-6						
29.95	57	115050	108	14090	5590	3	-	6	M1-6						
35.64	48	115050	91	14090	5640	3	-	6	M1-6						



8 R / RX - Helical

R / RX.. AD



Weight [lbs]	Stages		AD4	AD5	AD6	AD7	AD8
	Large	Small					
R147	2	-	825	851	877	876	924
	3	-	854	880	906	905	953

RF147: +20 lbs / RM147: +390 lbs

8.2.21 R147R77

R147R77 AD.. , n _e = 1700 rpm										115050 lb-in		
i [ratio]	n _a [rpm]	T _a max [lb-in]	P _e [HP]	F _{Ra} ¹⁾ [lb]	F _{Re} [lb]	Stages		φ ^(/R) [']				
						Lg	Sm					
415	4.1	115050	8.1	14090	220	3	2	-	-			
489	3.5	115050	6.8	14090	250	3	2	-	-			
558	3.0	115050	6.0	14090	260	3	2	-	-			
619	2.7	115050	5.4	14090	260	3	2	-	-			
695	2.4	115050	4.8	14090	310	3	2	-	-			
784	2.2	115050	4.3	14090	310	3	2	-	-			
889	1.9	115050	3.8	14090	320	3	2	-	-			
1029	1.7	115050	3.3	14090	330	3	2	-	-			
1166	1.5	115050	2.9	14090	340	3	2	-	-			
1329	1.3	115050	2.5	14090	340	3	2	-	-			
1536	1.1	115050	2.2	14090	350	3	2	-	-			
1705	1.0	115050	2.0	14090	350	3	2	-	-			
1951	0.87	115050	1.7	14090	340	3	2	-	-			
2211	0.77	115050	1.5	14090	290	3	2	-	-			
2555	0.67	115050	1.3	14090	310	3	2	-	-			
2898	0.59	115050	1.2	14090	370	3	3	-	-			
3302	0.51	115050	1.0	14090	370	3	3	-	-		R147R77	AD2
3754	0.45	115050	0.91	14090	370	3	3	-	-			
4325	0.39	115050	0.79	14090	380	3	3	-	-			
4926	0.35	115050	0.69	14090	380	3	3	-	-			
5568	0.31	115050	0.61	14090	380	3	3	-	-			
6447	0.26	115050	0.53	14090	390	3	3	-	-			
7307	0.23	115050	0.47	14090	390	3	3	-	-			
8443	0.20	115050	0.40	14090	390	3	3	-	-			
9743	0.17	115050	0.35	14090	390	3	3	-	-			
11143	0.15	115050	0.30	14090	390	3	3	-	-			
12344	0.14	115050	0.28	14090	390	3	3	-	-			
14075	0.12	115050	0.24	14090	390	3	3	-	-			
15923	0.11	115050	0.21	14090	390	3	3	-	-			
18210	0.09	115050	0.19	14090	390	3	3	-	-			
21342	0.08	115050	0.16	14090	390	3	3	-	-			
23401	0.07	115050	0.15	14090	390	3	3	-	-			
415	4.1	115050	8.1	14090	440	3	2	-	-			
489	3.5	115050	6.8	14090	470	3	2	-	-			
558	3.0	115050	6.0	14090	470	3	2	-	-			
619	2.7	115050	5.4	14090	480	3	2	-	-			
695	2.4	115050	4.8	14090	520	3	2	-	-			
784	2.2	115050	4.3	14090	530	3	2	-	-			
889	1.9	115050	3.8	14090	530	3	2	-	-			
1029	1.7	115050	3.3	14090	550	3	2	-	-			
1166	1.5	115050	2.9	14090	550	3	2	-	-			
1329	1.3	115050	2.5	14090	550	3	2	-	-		R147R77	AD3
1536	1.1	115050	2.2	14090	560	3	2	-	-			
1705	1.0	115050	2.0	14090	560	3	2	-	-			
1951	0.87	115050	1.7	14090	560	3	2	-	-			
2211	0.77	115050	1.5	14090	560	3	2	-	-			
2555	0.67	115050	1.3	14090	570	3	2	-	-			
2898	0.59	115050	1.2	14090	580	3	3	-	-			
3302	0.51	115050	1.0	14090	580	3	3	-	-			
3754	0.45	115050	0.91	14090	590	3	3	-	-			



R147R77 AD.. , n_e = 1700 rpm 115050 lb-in

i [ratio]	n _a [rpm]	T _{a max} [lb-in]	P _e [HP]	F _{Ra} ¹⁾ [lb]	F _{Re} [lb]	Stages		φ (/R) [']		
						Lg	Sm			
4325	0.39	115050	0.79	14090	590	3	3	-	-	R147R77 AD3
4926	0.35	115050	0.69	14090	590	3	3	-	-	
5568	0.31	115050	0.61	14090	600	3	3	-	-	
6447	0.26	115050	0.53	14090	600	3	3	-	-	
7307	0.23	115050	0.47	14090	600	3	3	-	-	
8443	0.20	115050	0.40	14090	600	3	3	-	-	
9743	0.17	115050	0.35	14090	600	3	3	-	-	
11143	0.15	115050	0.30	14090	600	3	3	-	-	
12344	0.14	115050	0.28	14090	600	3	3	-	-	
415	4.1	115050	8.1	14090	840	3	2	-	-	
489	3.5	115050	6.8	14090	860	3	2	-	-	
558	3.0	115050	6.0	14090	860	3	2	-	-	
619	2.7	115050	5.4	14090	870	3	2	-	-	
695	2.4	115050	4.8	14090	910	3	2	-	-	
784	2.2	115050	4.3	14090	910	3	2	-	-	
889	1.9	115050	3.8	14090	920	3	2	-	-	
1029	1.7	115050	3.3	14090	930	3	2	-	-	
1166	1.5	115050	2.9	14090	930	3	2	-	-	
1329	1.3	115050	2.5	14090	930	3	2	-	-	
1536	1.1	115050	2.2	14090	940	3	2	-	-	
1705	1.0	115050	2.0	14090	950	3	2	-	-	
2898	0.59	115050	1.2	14090	960	3	3	-	-	
3302	0.51	115050	1.0	14090	960	3	3	-	-	
4325	0.39	115050	0.79	14090	970	3	3	-	-	
5568	0.31	115050	0.61	14090	970	3	3	-	-	
6447	0.26	115050	0.53	14090	980	3	3	-	-	
7307	0.23	115050	0.47	14090	980	3	3	-	-	
8443	0.20	115050	0.40	14090	980	3	3	-	-	

Weight [lbs]	Stages		AD2	AD3	AD4
	Large	Small			
R147R77	3	2	920	928	941
	3	3	922	930	943

RF147: +20 lbs / RM147: +390 lbs

8.2.22 R147R87

R147R87 AD.. , n _e = 1700 rpm										115050 lb-in			
i [ratio]	n _a [rpm]	T _a max [lb-in]	P _e [HP]	F _{Ra} ¹⁾ [lb]	F _{Re} [lb]	Stages		φ _(/R) [']					
						Lg	Sm						
368	4.6	115050	9.1	14090	210	3	2	-	-				
426	4.0	115050	7.9	14090	240	3	2	-	-	R147R87	AD2		
462	3.7	115050	7.2	14090	290	3	2	-	-				
533	3.2	115050	6.3	14090	290	3	2	-	-				
189	9.0	115050	17.7	14090	330	3	2	-	-				
214	7.9	115050	15.6	14090	360	3	2	-	-	R147R87	AD3		
247	6.9	115050	13.6	14090	390	3	2	-	-				
280	6.1	115050	12.0	14090	420	3	2	-	-				
326	5.2	115050	10.3	14090	390	3	2	-	-				
368	4.6	115050	9.1	14090	410	3	2	-	-				
426	4.0	115050	7.9	14090	440	3	2	-	-				
462	3.7	115050	7.2	14090	480	3	2	-	-				
533	3.2	115050	6.3	14090	490	3	2	-	-				
159	11	115050	21	14090	720	3	2	-	-	R147R87	AD4		
189	9.0	115050	17.7	14090	760	3	2	-	-				
214	7.9	115050	15.6	14090	790	3	2	-	-				
247	6.9	115050	13.6	14090	810	3	2	-	-				
280	6.1	115050	12.0	14090	830	3	2	-	-				
326	5.2	115050	10.3	14090	810	3	2	-	-				
368	4.6	115050	9.1	14090	830	3	2	-	-				
426	4.0	115050	7.9	14090	850	3	2	-	-				
462	3.7	115050	7.2	14090	890	3	2	-	-				
533	3.2	115050	6.3	14090	900	3	2	-	-				
159	11	115050	21	14090	1390	3	2	-	-			R147R87	AD5
189	9.0	115050	17.7	14090	1430	3	2	-	-				
214	7.9	115050	15.6	14090	1460	3	2	-	-				
247	6.9	115050	13.6	14090	1480	3	2	-	-				
280	6.1	115050	12.0	14090	1500	3	2	-	-				
326	5.2	115050	10.3	14090	1470	3	2	-	-				
368	4.6	115050	9.1	14090	1490	3	2	-	-				
426	4.0	115050	7.9	14090	1520	3	2	-	-				
462	3.7	115050	7.2	14090	1560	3	2	-	-				
533	3.2	115050	6.3	14090	1560	3	2	-	-				
Weight [lbs]		Stages		AD2	AD3	AD4	AD5						
		Large	Small										
R147R87		3	2	965	974	987	1020						
RF147: +20 lbs / RM147: +390 lbs													

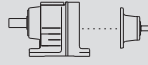

8.2.23 R167

R167 AD.. , n _e = 1700 rpm										159300 lb-in		
i [ratio]	n _a [rpm]	T _{a max} [lb-in]	P _e [HP]	F _{Ra} ¹⁾ [lb]	F _{Re} [lb]	Stages		φ (/R) [']				
						Lg	Sm					
73.70	23	159300	61	26980	560	3	-	6	-	R167	AD5	
82.91	21	159300	54	26980	1120	3	-	5	M2,4			
93.19	18	159300	48	26980	1140	3	-	5	M2			
107.49	16	159300	42	26980	1160	3	-	5	-			
121.81	14	159300	37	26980	1180	3	-	5	-			
139.98	12	159300	32	26980	1200	3	-	5	-			
153.07	11	159300	29	26980	1210	3	-	5	-			
186.93	9.1	159300	24	26980	1240	3	-	5	-			
229.71	7.4	159300	19.6	26980	1250	3	-	5	-			
30.71	55	88500	80	26980	760	2	-	5	-	R167	AD6	
34.41	49	110630	91	26980	1480	3	-	6	M1-6			
37.74	45	79650	59	26980	1140	2	-	5	-			
39.92	43	128330	91	26980	1400	3	-	6	M1-6			
44.87	38	144260	91	26980	1330	3	-	6	M1-6			
51.76	33	159300	87	26980	1230	3	-	6	M1-6			
58.65	29	159300	77	26980	1300	3	-	6	M2,4			
67.40	25	159300	67	26980	1350	3	-	6	-			
73.70	23	159300	61	26980	1370	3	-	6	-			
82.91	21	159300	54	26980	1730	3	-	5	M2,4			
93.19	18	159300	48	26980	1750	3	-	5	M2			
107.49	16	159300	42	26980	1770	3	-	5	-			
121.81	14	159300	37	26980	1790	3	-	5	-			
139.98	12	159300	32	26980	1800	3	-	5	-			
153.07	11	159300	29	26980	1810	3	-	5	-			
186.93	9.1	159300	24	26980	1840	3	-	5	-			
30.71	55	88500	80	26980	2380	2	-	5	-	R167	AD7	
34.41	49	159300	131	26980	2780	3	-	6	M1-6			
39.92	43	159300	113	26980	2960	3	-	6	M1-6			
44.87	38	159300	100	26980	3120	3	-	6	M1-6			
51.76	33	159300	87	26980	3300	3	-	6	M1-6			
58.65	29	159300	77	26980	3430	3	-	6	M2,4			
67.40	25	159300	67	26980	3520	3	-	6	-			
73.70	23	159300	61	26980	3540	3	-	6	-			
82.91	21	159300	54	26980	3830	3	-	5	M2,4			
93.19	18	159300	48	26980	3850	3	-	5	M2			
107.49	16	159300	42	26980	3870	3	-	5	-			
121.81	14	159300	37	26980	3890	3	-	5	-			
139.98	12	159300	32	26980	3900	3	-	5	-			
153.07	11	159300	29	26980	3910	3	-	5	-			
10.24	166	150450	408	16910	3980	2	-	5	M1-6			
11.99	142	150450	349	18230	4140	2	-	5	M1-6			
14.48	117	159300	306	19280	4180	2	-	5	M1-6			
16.98	100	132750	217	22580	4660	2	-	5	M1-6			
19.03	89	141600	207	23080	4610	2	-	5	M1-6			
21.85	78	115050	146	26270	5000	2	-	5	M1-6			
23.71	72	159300	190	24100	5260	3	-	6	M1-6			
24.57	69	123900	140	26890	4940	2	-	5	M1-6			
27.96	61	159300	161	25870	5350	3	-	6	M1-6			
34.41	49	159300	131	26980	5440	3	-	6	M1-6			
39.92	43	159300	113	26980	5490	3	-	6	M1-6			
44.87	38	159300	100	26980	5520	3	-	6	M1-6			
51.76	33	159300	87	26980	5560	3	-	6	M1-6			
58.65	29	159300	77	26980	5590	3	-	6	M2,4			
82.91	21	159300	54	26980	5960	3	-	5	M2,4			
93.19	18	159300	48	26980	5980	3	-	5	M2			
107.49	16	159300	42	26980	5990	3	-	5	-			
121.81	14	159300	37	26980	6010	3	-	5	-			



Weight [lbs]	Stages		AD5	AD6	AD7	AD8
	Large	Small				
R167	2	-	1415	1452	1439	1491
	3	-	1429	1466	1453	1505

RF167: +20 lbs / RM167: +450 lbs

8.2.24 R167R97

R167R97 AD.. , n _e = 1700 rpm										159300 lb-in		
i [ratio]	n _a [rpm]	T _a max [lb-in]	P _e [HP]	F _{Ra} ¹⁾ [lb]	F _{Re} [lb]	Stages		φ (/R) [']				
						Lg	Sm					
279	6.1	159300	16.6	26980	360	3	2	-	-			
303	5.6	159300	15.3	26980	380	3	2	-	-			
335	5.1	159300	13.8	26980	360	3	2	-	-			
376	4.5	159300	12.3	26980	390	3	2	-	-			
432	3.9	159300	10.7	26980	440	3	2	-	-			
503	3.4	159300	9.2	26980	440	3	2	-	-			
579	2.9	159300	8.0	26980	480	3	2	-	-			
656	2.6	159300	7.1	26980	470	3	2	-	-			
760	2.2	159300	6.1	26980	440	3	2	-	-			
861	2.0	159300	5.4	26980	460	3	2	-	-			
999	1.7	159300	4.6	26980	480	3	2	-	-			
1123	1.5	159300	4.1	26980	490	3	2	-	-			
1279	1.3	159300	3.6	26980	480	3	2	-	-			
1438	1.2	159300	3.2	26980	500	3	2	-	-			
1670	1.0	159300	2.8	26980	530	3	2	-	-			
1877	0.91	159300	2.5	26980	540	3	2	-	-			
2085	0.82	159300	2.2	26980	540	3	2	-	-			
2333	0.73	159300	2.0	26980	540	3	2	-	-			
2657	0.64	159300	1.7	26980	540	3	2	-	-			
3099	0.55	159300	1.5	26980	560	3	3	-	-			
3692	0.46	159300	1.3	26980	560	3	3	-	-			
4129	0.41	159300	1.1	26980	560	3	3	-	-			
4650	0.37	159300	1.0	26980	560	3	3	-	-			
5407	0.31	159300	0.87	26980	560	3	3	-	-			
6077	0.28	159300	0.77	26980	570	3	3	-	-			
6894	0.25	159300	0.68	26980	570	3	3	-	-			
7749	0.22	159300	0.61	26980	570	3	3	-	-			
10509	0.16	159300	0.45	26980	570	3	3	-	-			
11812	0.14	159300	0.40	26980	580	3	3	-	-			
14051	0.12	159300	0.33	26980	580	3	3	-	-			
15446	0.11	159300	0.30	26980	580	3	3	-	-			
17361	0.10	159300	0.27	26980	580	3	3	-	-			
279	6.1	159300	16.6	26980	790	3	2	-	-			
303	5.6	159300	15.3	26980	800	3	2	-	-			
335	5.1	159300	13.8	26980	790	3	2	-	-			
376	4.5	159300	12.3	26980	810	3	2	-	-			
432	3.9	159300	10.7	26980	860	3	2	-	-			
503	3.4	159300	9.2	26980	850	3	2	-	-			
579	2.9	159300	8.0	26980	890	3	2	-	-			
656	2.6	159300	7.1	26980	880	3	2	-	-			
760	2.2	159300	6.1	26980	850	3	2	-	-			
861	2.0	159300	5.4	26980	870	3	2	-	-			
999	1.7	159300	4.6	26980	890	3	2	-	-			
1123	1.5	159300	4.1	26980	900	3	2	-	-			
1279	1.3	159300	3.6	26980	900	3	2	-	-			
1438	1.2	159300	3.2	26980	910	3	2	-	-			
1670	1.0	159300	2.8	26980	940	3	2	-	-			
1877	0.91	159300	2.5	26980	940	3	2	-	-			
2085	0.82	159300	2.2	26980	940	3	2	-	-			
2333	0.73	159300	2.0	26980	940	3	2	-	-			

R167R97 AD.. , n_e = 1700 rpm 159300 lb-in

i [ratio]	n _a [rpm]	T _a max [lb-in]	P _e [HP]	F _{Ra} ¹⁾ [lb]	F _{Re} [lb]	Stages		φ (/R) [']			
						Lg	Sm				
2657	0.64	159300	1.7	26980	940	3	2	-	-	R167R97 AD4	
3099	0.55	159300	1.5	26980	960	3	3	-	-		
3692	0.46	159300	1.3	26980	960	3	3	-	-		
4129	0.41	159300	1.1	26980	960	3	3	-	-		
4650	0.37	159300	1.0	26980	960	3	3	-	-		
5407	0.31	159300	0.87	26980	970	3	3	-	-		
6077	0.28	159300	0.77	26980	970	3	3	-	-		
6894	0.25	159300	0.68	26980	970	3	3	-	-		
7749	0.22	159300	0.61	26980	970	3	3	-	-		
10509	0.16	159300	0.45	26980	980	3	3	-	-		
11812	0.14	159300	0.40	26980	980	3	3	-	-		
14051	0.12	159300	0.33	26980	980	3	3	-	-		
279	6.1	159300	16.6	26980	1460	3	2	-	-		R167R97 AD5
303	5.6	159300	15.3	26980	1470	3	2	-	-		
335	5.1	159300	13.8	26980	1460	3	2	-	-		
376	4.5	159300	12.3	26980	1480	3	2	-	-		
432	3.9	159300	10.7	26980	1520	3	2	-	-		
503	3.4	159300	9.2	26980	1520	3	2	-	-		
579	2.9	159300	8.0	26980	1560	3	2	-	-		
656	2.6	159300	7.1	26980	1550	3	2	-	-		
861	2.0	159300	5.4	26980	1540	3	2	-	-		
999	1.7	159300	4.6	26980	1550	3	2	-	-		
1123	1.5	159300	4.1	26980	1560	3	2	-	-		
1670	1.0	159300	2.8	26980	1600	3	2	-	-		
1877	0.91	159300	2.5	26980	1600	3	2	-	-		
2085	0.82	159300	2.2	26980	1610	3	2	-	-		
2333	0.73	159300	2.0	26980	1610	3	2	-	-		
3099	0.55	159300	1.5	26980	1630	3	3	-	-		
3692	0.46	159300	1.3	26980	1630	3	3	-	-		
4129	0.41	159300	1.1	26980	1630	3	3	-	-		
4650	0.37	159300	1.0	26980	1630	3	3	-	-		
6894	0.25	159300	0.68	26980	1640	3	3	-	-		
7749	0.22	159300	0.61	26980	1640	3	3	-	-		
279	6.1	159300	16.6	26980	2040	3	2	-	-	R167R97 AD6	
303	5.6	159300	15.3	26980	2060	3	2	-	-		
335	5.1	159300	13.8	26980	2040	3	2	-	-		
376	4.5	159300	12.3	26980	2060	3	2	-	-		
432	3.9	159300	10.7	26980	2110	3	2	-	-		
503	3.4	159300	9.2	26980	2100	3	2	-	-		
579	2.9	159300	8.0	26980	2140	3	2	-	-		
656	2.6	159300	7.1	26980	2130	3	2	-	-		
1670	1.0	159300	2.8	26980	2180	3	2	-	-		
1877	0.91	159300	2.5	26980	2180	3	2	-	-		
3099	0.55	159300	1.5	26980	2200	3	3	-	-		
3692	0.46	159300	1.3	26980	2200	3	3	-	-		
6894	0.25	159300	0.68	26980	2210	3	3	-	-		
7749	0.22	159300	0.61	26980	2210	3	3	-	-		



Weight [lbs]	Stages		AD3	AD4	AD5	AD6
	Large	Small				
R167R97	3	2	1653	1665	1701	1731
	3	3	1660	1671	1708	1738

RF167: +20 lbs / RM167: +450 lbs

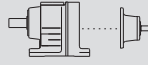
8.2.25 R167R107

R167R107 AD.. , n _e = 1700 rpm										159300 lb-in	
i [ratio]	n _a [rpm]	T _a max [lb-in]	P _e [HP]	F _{RA} ¹⁾ [lb]	F _{Re} [lb]	Stages		φ ^(/R) [']			
						Lg	Sm				
229	7.4	159300	20	26980	340	3	2	-	-		
264	6.4	159300	17.3	26980	310	2	2	-	-		
270	6.3	159300	17.2	26980	360	3	2	-	-		
291	5.8	159300	15.7	26980	320	2	2	-	-		
328	5.2	159300	13.9	26980	330	2	2	-	-		
349	4.9	159300	13.3	26980	430	3	2	-	-		
361	4.7	159300	12.6	26980	340	2	2	-	-		
399	4.3	159300	11.4	26980	350	2	2	-	-		
446	3.8	159300	10.2	26980	360	2	2	-	-		
511	3.3	159300	9.1	26980	460	2	3	-	-		
585	2.9	159300	7.9	26980	470	2	3	-	-		
690	2.5	159300	6.7	26980	480	2	3	-	-		
763	2.2	159300	6.1	26980	480	2	3	-	-		
860	2.0	159300	5.4	26980	490	2	3	-	-		
950	1.8	159300	4.9	26980	490	2	3	-	-		
1111	1.5	159300	4.2	26980	520	2	3	-	-		
1229	1.4	159300	3.8	26980	520	2	3	-	-		
1342	1.3	159300	3.5	26980	530	2	3	-	-		
1485	1.1	159300	3.1	26980	530	2	3	-	-		
1674	1.0	159300	2.8	26980	530	2	3	-	-		
1849	0.92	159300	2.5	26980	540	2	3	-	-		
2066	0.82	159300	2.2	26980	530	2	3	-	-		
2298	0.74	159300	2.0	26980	540	2	3	-	-		
2436	0.70	159300	1.9	26980	530	2	3	-	-		
2757	0.62	159300	1.7	26980	530	2	3	-	-		
3330	0.51	159300	1.4	26980	540	2	3	-	-		
3637	0.47	159300	1.3	26980	540	2	3	-	-		
168	10	159300	27	26980	690	2	2	-	-		
169	10	159300	27	26980	730	3	2	-	-		
198	8.6	159300	23	26980	710	2	2	-	-		
200	8.5	159300	23	26980	750	3	2	-	-		
227	7.5	159300	20	26980	730	2	2	-	-		
229	7.4	159300	20	26980	770	3	2	-	-		
264	6.4	159300	17.3	26980	740	2	2	-	-		
270	6.3	159300	17.2	26980	780	3	2	-	-		
291	5.8	159300	15.7	26980	750	2	2	-	-		
295	5.8	159300	15.7	26980	840	3	2	-	-		
328	5.2	159300	13.9	26980	760	2	2	-	-		
349	4.9	159300	13.3	26980	850	3	2	-	-		
361	4.7	159300	12.6	26980	760	2	2	-	-		
399	4.3	159300	11.4	26980	780	2	2	-	-		
446	3.8	159300	10.2	26980	780	2	2	-	-		
511	3.3	159300	9.1	26980	880	2	3	-	-		
585	2.9	159300	7.9	26980	880	2	3	-	-		
690	2.5	159300	6.7	26980	890	2	3	-	-		
763	2.2	159300	6.1	26980	890	2	3	-	-		
860	2.0	159300	5.4	26980	900	2	3	-	-		
950	1.8	159300	4.9	26980	900	2	3	-	-		
1111	1.5	159300	4.2	26980	930	2	3	-	-		
1229	1.4	159300	3.8	26980	930	2	3	-	-		
1342	1.3	159300	3.5	26980	930	2	3	-	-		
1485	1.1	159300	3.1	26980	940	2	3	-	-		
1674	1.0	159300	2.8	26980	940	2	3	-	-		
1849	0.92	159300	2.5	26980	940	2	3	-	-		
2066	0.82	159300	2.2	26980	940	2	3	-	-		
2298	0.74	159300	2.0	26980	940	2	3	-	-		
2436	0.70	159300	1.9	26980	940	2	3	-	-		

R167R107 AD.. , n_e = 1700 rpm 159300 lb-in

i [ratio]	n _a [rpm]	T _a max [lb-in]	P _e [HP]	F _{Ra} ¹⁾ [lb]	F _{Re} [lb]	Stages		φ _(/R) [']		
						Lg	Sm			
168	10	159300	27	26980	1370	2	2	-	-	R167R107 AD5
169	10	159300	27	26980	1410	3	2	-	-	
198	8.6	159300	23	26980	1390	2	2	-	-	
200	8.5	159300	23	26980	1430	3	2	-	-	
227	7.5	159300	20	26980	1400	2	2	-	-	
229	7.4	159300	20	26980	1440	3	2	-	-	
264	6.4	159300	17.3	26980	1410	2	2	-	-	
270	6.3	159300	17.2	26980	1450	3	2	-	-	
291	5.8	159300	15.7	26980	1420	2	2	-	-	
295	5.8	159300	15.7	26980	1510	3	2	-	-	
328	5.2	159300	13.9	26980	1430	2	2	-	-	
349	4.9	159300	13.3	26980	1520	3	2	-	-	
361	4.7	159300	12.6	26980	1430	2	2	-	-	
399	4.3	159300	11.4	26980	1440	2	2	-	-	
446	3.8	159300	10.2	26980	1450	2	2	-	-	
511	3.3	159300	9.1	26980	1540	2	3	-	-	
585	2.9	159300	7.9	26980	1550	2	3	-	-	
690	2.5	159300	6.7	26980	1550	2	3	-	-	
763	2.2	159300	6.1	26980	1560	2	3	-	-	
860	2.0	159300	5.4	26980	1560	2	3	-	-	
950	1.8	159300	4.9	26980	1560	2	3	-	-	
1111	1.5	159300	4.2	26980	1590	2	3	-	-	
1229	1.4	159300	3.8	26980	1590	2	3	-	-	
1342	1.3	159300	3.5	26980	1600	2	3	-	-	
1485	1.1	159300	3.1	26980	1600	2	3	-	-	
1674	1.0	159300	2.8	26980	1600	2	3	-	-	
1849	0.92	159300	2.5	26980	1600	2	3	-	-	
2298	0.74	159300	2.0	26980	1610	2	3	-	-	
168	10	159300	27	26980	1960	2	2	-	-	R167R107 AD6
169	10	159300	27	26980	2000	3	2	-	-	
198	8.6	159300	23	26980	1980	2	2	-	-	
200	8.5	159300	23	26980	2020	3	2	-	-	
227	7.5	159300	20	26980	1990	2	2	-	-	
229	7.4	159300	20	26980	2030	3	2	-	-	
264	6.4	159300	17.3	26980	2000	2	2	-	-	
270	6.3	159300	17.2	26980	2040	3	2	-	-	
291	5.8	159300	15.7	26980	2010	2	2	-	-	
295	5.8	159300	15.7	26980	2090	3	2	-	-	
328	5.2	159300	13.9	26980	2010	2	2	-	-	
349	4.9	159300	13.3	26980	2100	3	2	-	-	
361	4.7	159300	12.6	26980	2020	2	2	-	-	
511	3.3	159300	9.1	26980	2120	2	3	-	-	
585	2.9	159300	7.9	26980	2130	2	3	-	-	
690	2.5	159300	6.7	26980	2140	2	3	-	-	
763	2.2	159300	6.1	26980	2140	2	3	-	-	
860	2.0	159300	5.4	26980	2140	2	3	-	-	
950	1.8	159300	4.9	26980	2140	2	3	-	-	
1111	1.5	159300	4.2	26980	2170	2	3	-	-	
1229	1.4	159300	3.8	26980	2170	2	3	-	-	
1342	1.3	159300	3.5	26980	2180	2	3	-	-	
1485	1.1	159300	3.1	26980	2180	2	3	-	-	
1674	1.0	159300	2.8	26980	2180	2	3	-	-	
1849	0.92	159300	2.5	26980	2180	2	3	-	-	

Weight [lbs]	Stages		AD3	AD4	AD5	AD6
	Large	Small				
R167R107	2	2	1744	1758	1788	1818
	2	3	1758	1772	1802	1832
	3	2	1758	1772	1802	1832

RF167: +20 lbs / RM167: +450 lbs

8.3 R/RX.. AM.. [NEMA dimensions]

01 009 00 11

RX57..

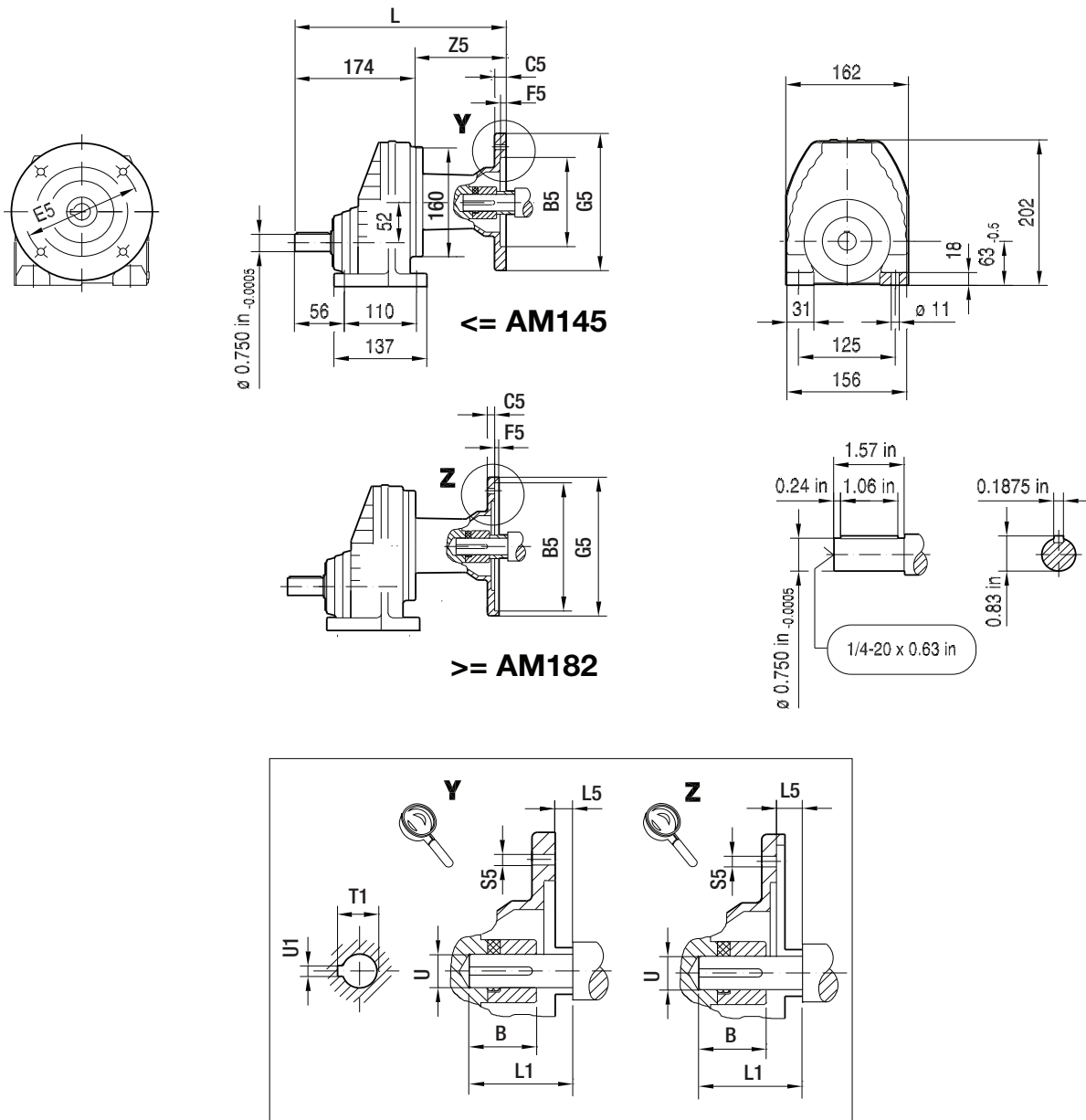

(→ 132)	B	B5	C5	E5	F5	G5	L	L1	L5	S5	T1	U	U1	Z5
AM56	1.23 in	4.50 in	11	5.875 in	4.5	170	261	1.88 in	-0.18 in	10.5	0.71 in	0.625 in	0.188 in	87
AM143	1.68 in	4.50 in	12	5.875 in	4.5	170	285	2.25 in	0.13 in	10.5	0.98 in	0.875 in	0.188 in	110.5
AM145	1.68 in	4.50 in	12	5.875 in	4.5	170	285	2.25 in	0.13 in	10.5	0.98 in	0.875 in	0.188 in	110.5
AM182	2.10 in	8.50 in	10	7.25 in	5	228	322	2.75 in	0.13 in	15	1.24 in	1.125 in	0.250 in	147.5
AM184	2.10 in	8.50 in	10	7.25 in	5	228	322	2.75 in	0.13 in	15	1.24 in	1.125 in	0.250 in	147.5
AM213/215	2.76 in	8.50 in	11	7.25 in	5	228	375	3.38 in	0.25 in	15	1.52 in	1.375 in	0.312 in	200.5

Dimensions in mm unless otherwise noted. For all available output shaft diameters, see page 274.

01 010 00 11

RXF57..

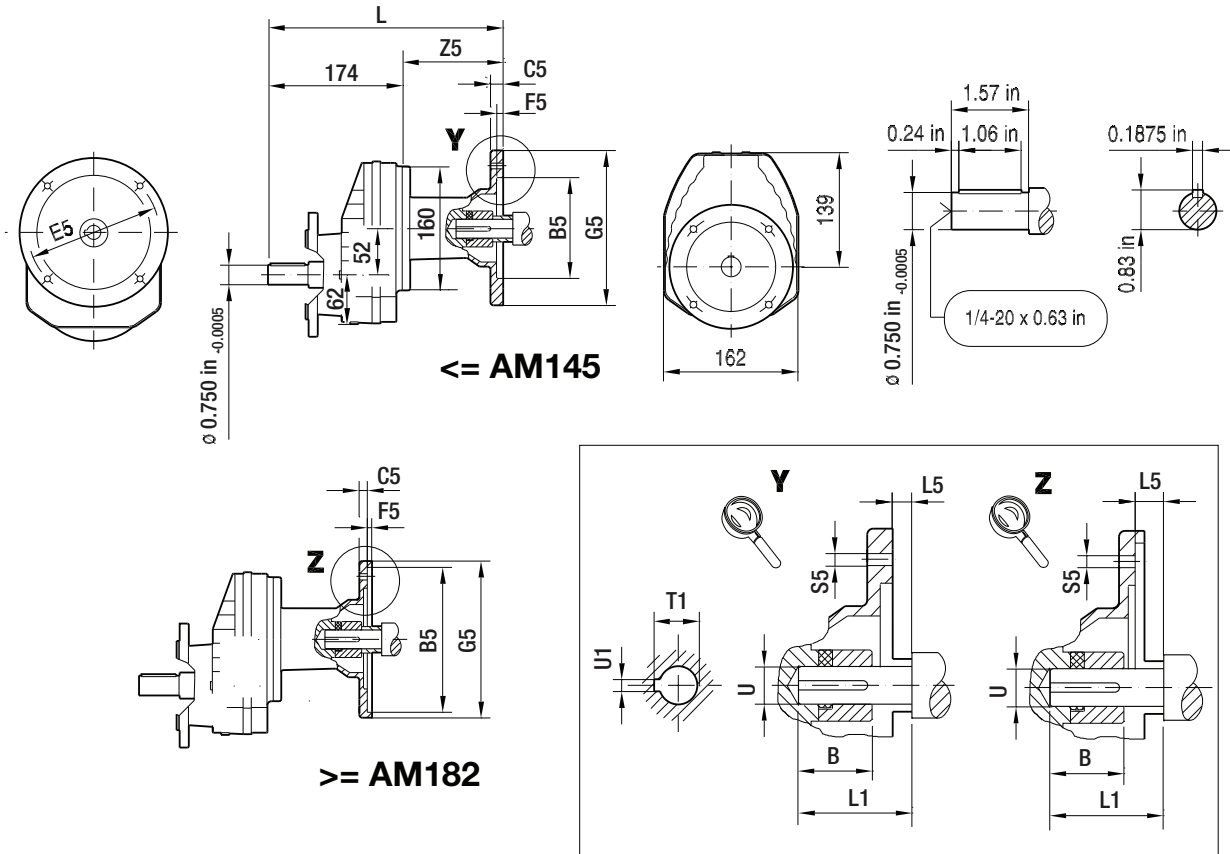

8

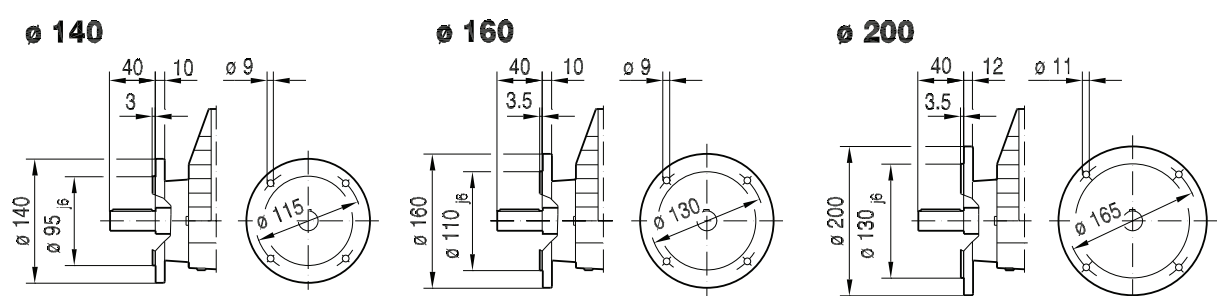

(→ 132)	B	B5	C5	E5	F5	G5	L	L1	L5	S5	T1	U	U1	Z5
AM56	1.23 in	4.50 in	11	5.875 in	4.5	170	261	1.88 in	-0.18 in	10.5	0.71 in	0.625 in	0.188 in	87
AM143	1.68 in	4.50 in	12	5.875 in	4.5	170	285	2.25 in	0.13 in	10.5	0.98 in	0.875 in	0.188 in	110.5
AM145	1.68 in	4.50 in	12	5.875 in	4.5	170	285	2.25 in	0.13 in	10.5	0.98 in	0.875 in	0.188 in	110.5
AM182	2.10 in	8.50 in	10	7.25 in	5	228	322	2.75 in	0.13 in	15	1.24 in	1.125 in	0.250 in	147.5
AM184	2.10 in	8.50 in	10	7.25 in	5	228	322	2.75 in	0.13 in	15	1.24 in	1.125 in	0.250 in	147.5
AM213/215	2.76 in	8.50 in	11	7.25 in	5	228	375	3.38 in	0.25 in	15	1.52 in	1.375 in	0.312 in	200.5

Dimensions in mm unless otherwise noted. For all available output shaft diameters, see page 274.

RX67..

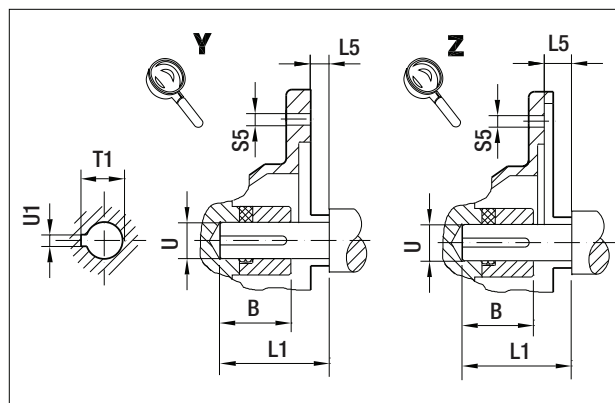
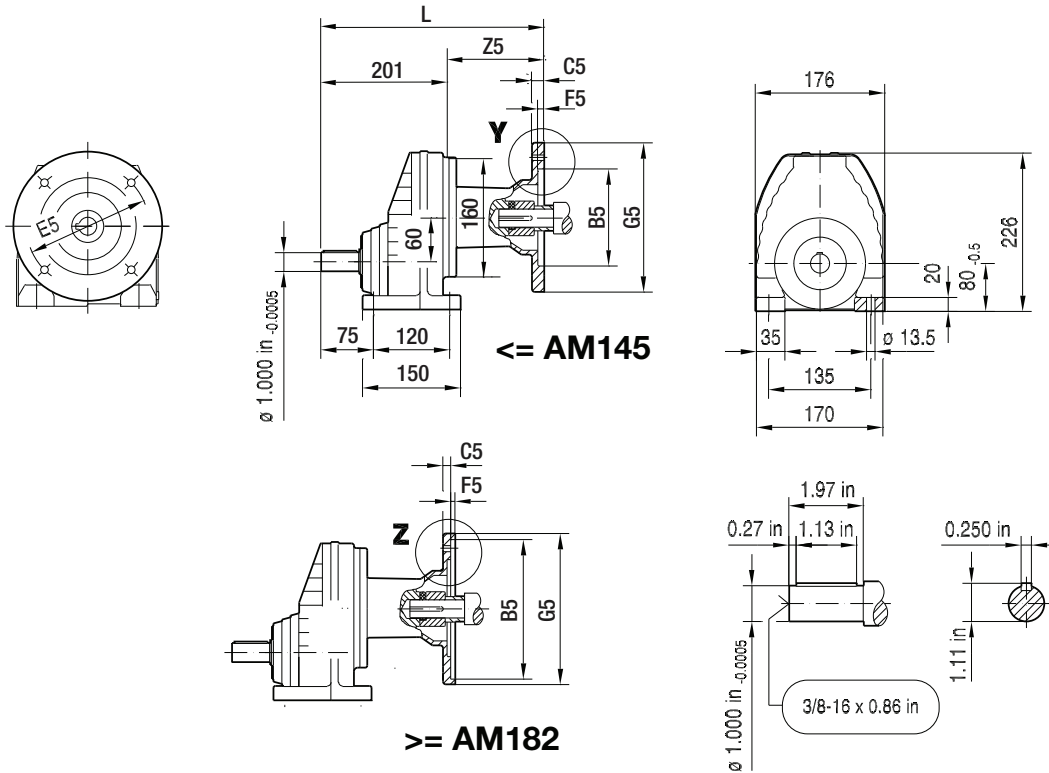

(→ 132)	B	B5	C5	E5	F5	G5	L	L1	L5	S5	T1	U	U1	Z5
AM56	1.23 in	4.50 in	11	5.875 in	4.5	170	288	1.88 in	-0.18 in	10.5	0.71 in	0.625 in	0.188 in	87
AM143	1.68 in	4.50 in	12	5.875 in	4.5	170	312	2.25 in	0.13 in	10.5	0.98 in	0.875 in	0.188 in	110.5
AM145	1.68 in	4.50 in	12	5.875 in	4.5	170	312	2.25 in	0.13 in	10.5	0.98 in	0.875 in	0.188 in	110.5
AM182	2.10 in	8.50 in	10	7.25 in	5	228	349	2.75 in	0.13 in	15	1.24 in	1.125 in	0.250 in	147.5
AM184	2.10 in	8.50 in	10	7.25 in	5	228	349	2.75 in	0.13 in	15	1.24 in	1.125 in	0.250 in	147.5
AM213/215	2.76 in	8.50 in	11	7.25 in	5	228	402	3.38 in	0.25 in	15	1.52 in	1.375 in	0.312 in	200.5

Dimensions in mm unless otherwise noted. For all available output shaft diameters, see page 274.

01 012 00 11

RXF67..

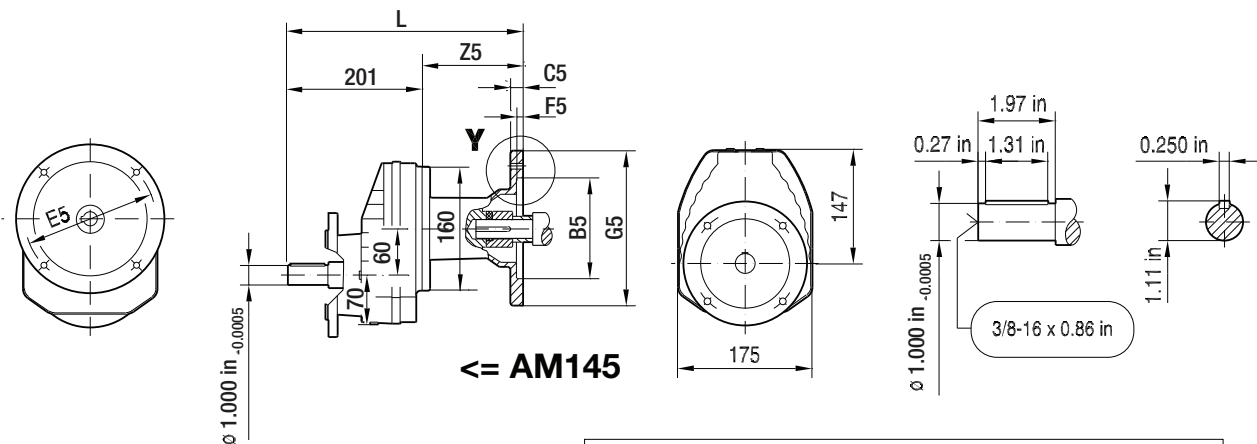

≤ AM145

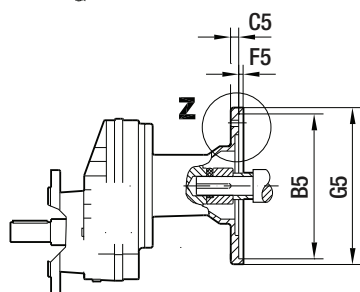

≥ AM182

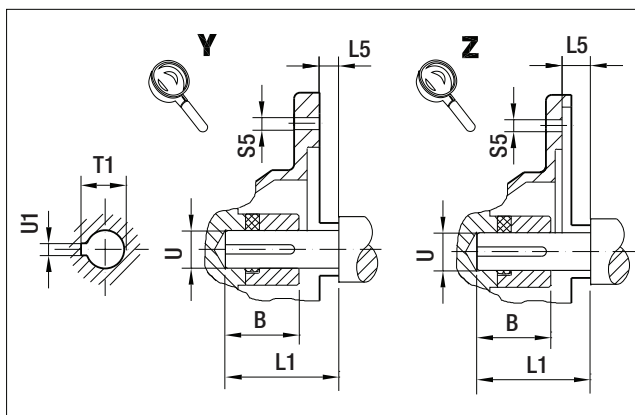

∅ 160

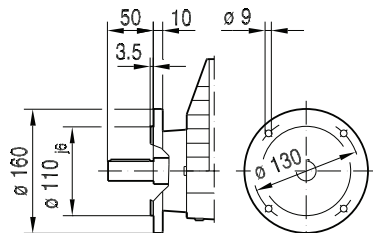

∅ 200

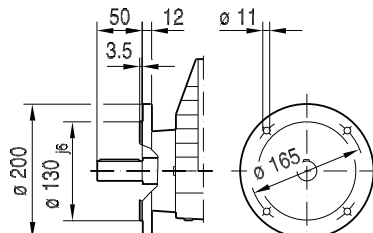

∅ 250

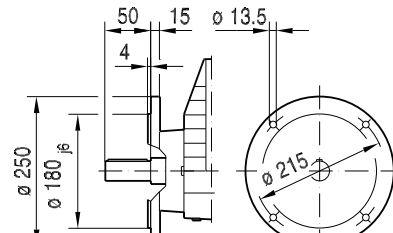

(→ 132)	B	B5	C5	E5	F5	G5	L	L1	L5	S5	T1	U	U1	Z5
AM56	1.23 in	4.50 in	11	5.875 in	4.5	170	288	1.88 in	-0.18 in	10.5	0.71 in	0.625 in	0.188 in	87
AM143	1.68 in	4.50 in	12	5.875 in	4.5	170	312	2.25 in	0.13 in	10.5	0.98 in	0.875 in	0.188 in	110.5
AM145	1.68 in	4.50 in	12	5.875 in	4.5	170	312	2.25 in	0.13 in	10.5	0.98 in	0.875 in	0.188 in	110.5
AM182	2.10 in	8.50 in	10	7.25 in	5	228	349	2.75 in	0.13 in	15	1.24 in	1.125 in	0.250 in	147.5
AM184	2.10 in	8.50 in	10	7.25 in	5	228	349	2.75 in	0.13 in	15	1.24 in	1.125 in	0.250 in	147.5
AM213/215	2.76 in	8.50 in	11	7.25 in	5	228	402	3.38 in	0.25 in	15	1.52 in	1.375 in	0.312 in	200.5

Dimensions in mm unless otherwise noted. For all available output shaft diameters, see page 274.

01 013 00 11

RX77..

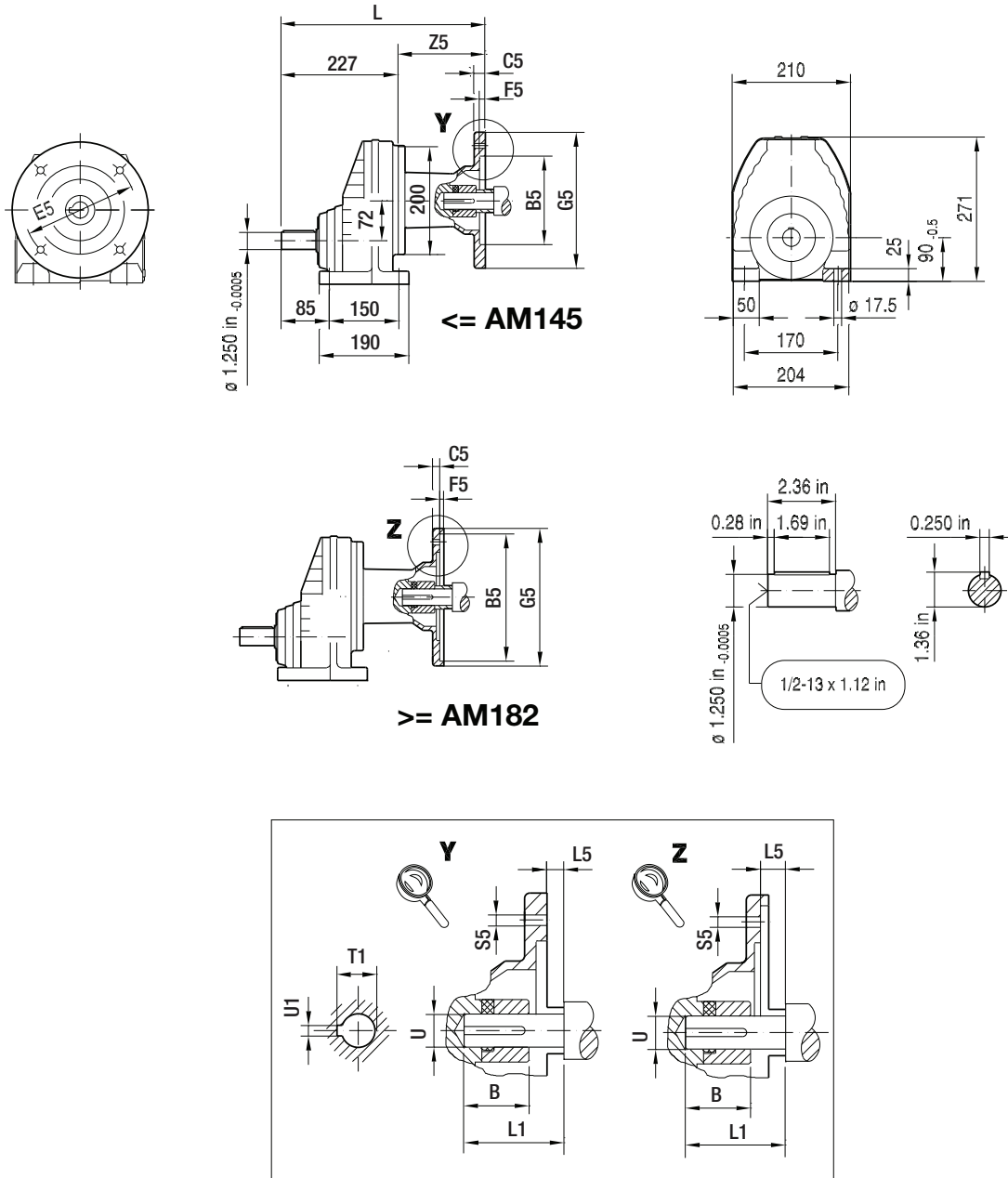

(→ 132)	B	B5	C5	E5	F5	G5	L	L1	L5	S5	T1	U	U1	Z5
AM56	1.23 in	4.50 in	11	5.875 in	4.5	170	308	1.88 in	-0.18 in	10.5	0.71 in	0.625 in	0.188 in	81
AM143	1.68 in	4.50 in	12	5.875 in	4.5	170	331	2.25 in	0.13 in	10.5	0.98 in	0.875 in	0.188 in	103.5
AM145	1.68 in	4.50 in	12	5.875 in	4.5	170	331	2.25 in	0.13 in	10.5	0.98 in	0.875 in	0.188 in	103.5
AM182	2.10 in	8.50 in	10	7.25 in	5	228	367	2.75 in	0.13 in	15	1.24 in	1.125 in	0.250 in	139.5
AM184	2.10 in	8.50 in	10	7.25 in	5	228	367	2.75 in	0.13 in	15	1.24 in	1.125 in	0.250 in	139.5
AM213/215	2.76 in	8.50 in	11	7.25 in	5	228	416	3.38 in	0.25 in	15	1.52 in	1.375 in	0.312 in	188.5

Dimensions in mm unless otherwise noted. For all available output shaft diameters, see page 274.

01 014 00 11

RXF77..

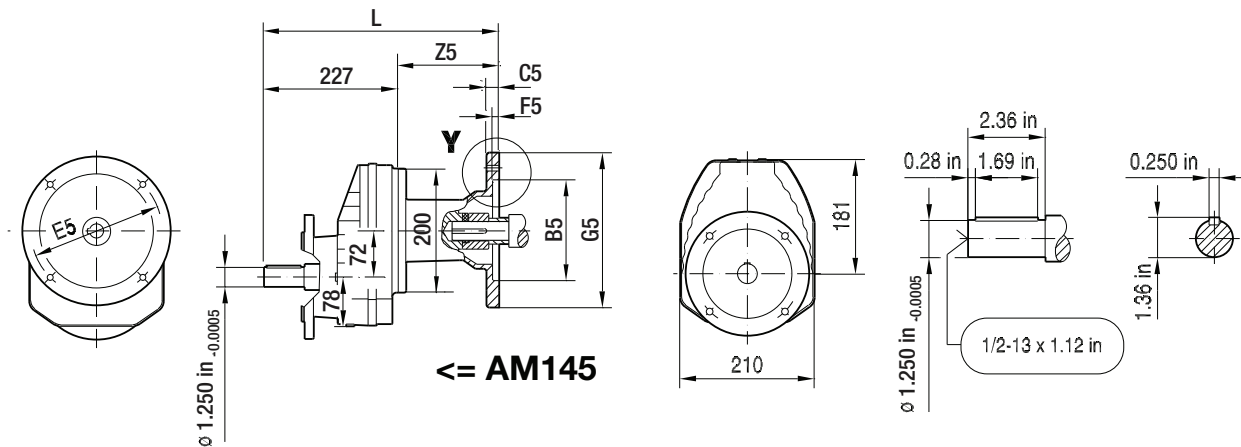

← AM145

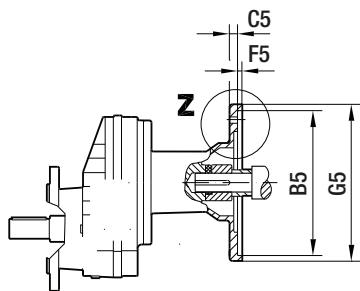

→ AM182

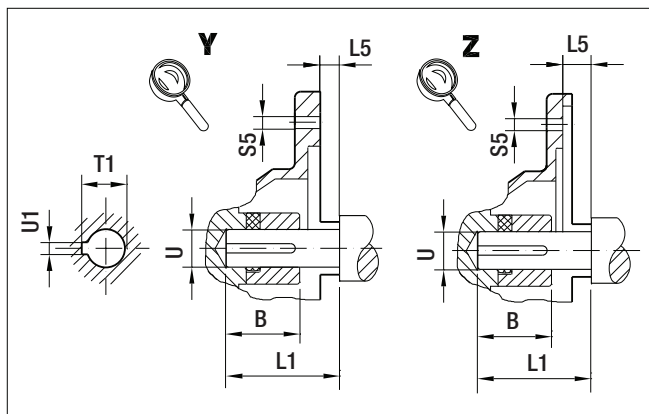

ø 200

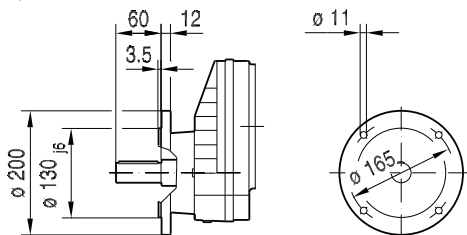

ø 250

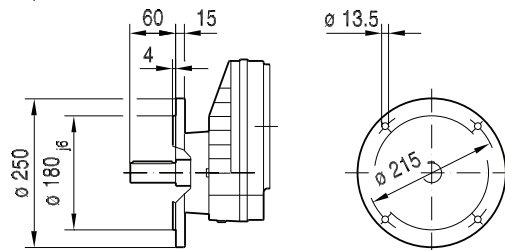

(→ 132)	B	B5	C5	E5	F5	G5	L	L1	L5	S5	T1	U	U1	Z5
AM56	1.23 in	4.50 in	11	5.875 in	4.5	170	308	1.88 in	-0.18 in	10.5	0.71 in	0.625 in	0.188 in	81
AM143	1.68 in	4.50 in	12	5.875 in	4.5	170	331	2.25 in	0.13 in	10.5	0.98 in	0.875 in	0.188 in	103.5
AM145	1.68 in	4.50 in	12	5.875 in	4.5	170	331	2.25 in	0.13 in	10.5	0.98 in	0.875 in	0.188 in	103.5
AM182	2.10 in	8.50 in	10	7.25 in	5	228	367	2.75 in	0.13 in	15	1.24 in	1.125 in	0.250 in	139.5
AM184	2.10 in	8.50 in	10	7.25 in	5	228	367	2.75 in	0.13 in	15	1.24 in	1.125 in	0.250 in	139.5
AM213/215	2.76 in	8.50 in	11	7.25 in	5	228	416	3.38 in	0.25 in	15	1.52 in	1.375 in	0.312 in	188.5

Dimensions in mm unless otherwise noted. For all available output shaft diameters, see page 274.

RX87..

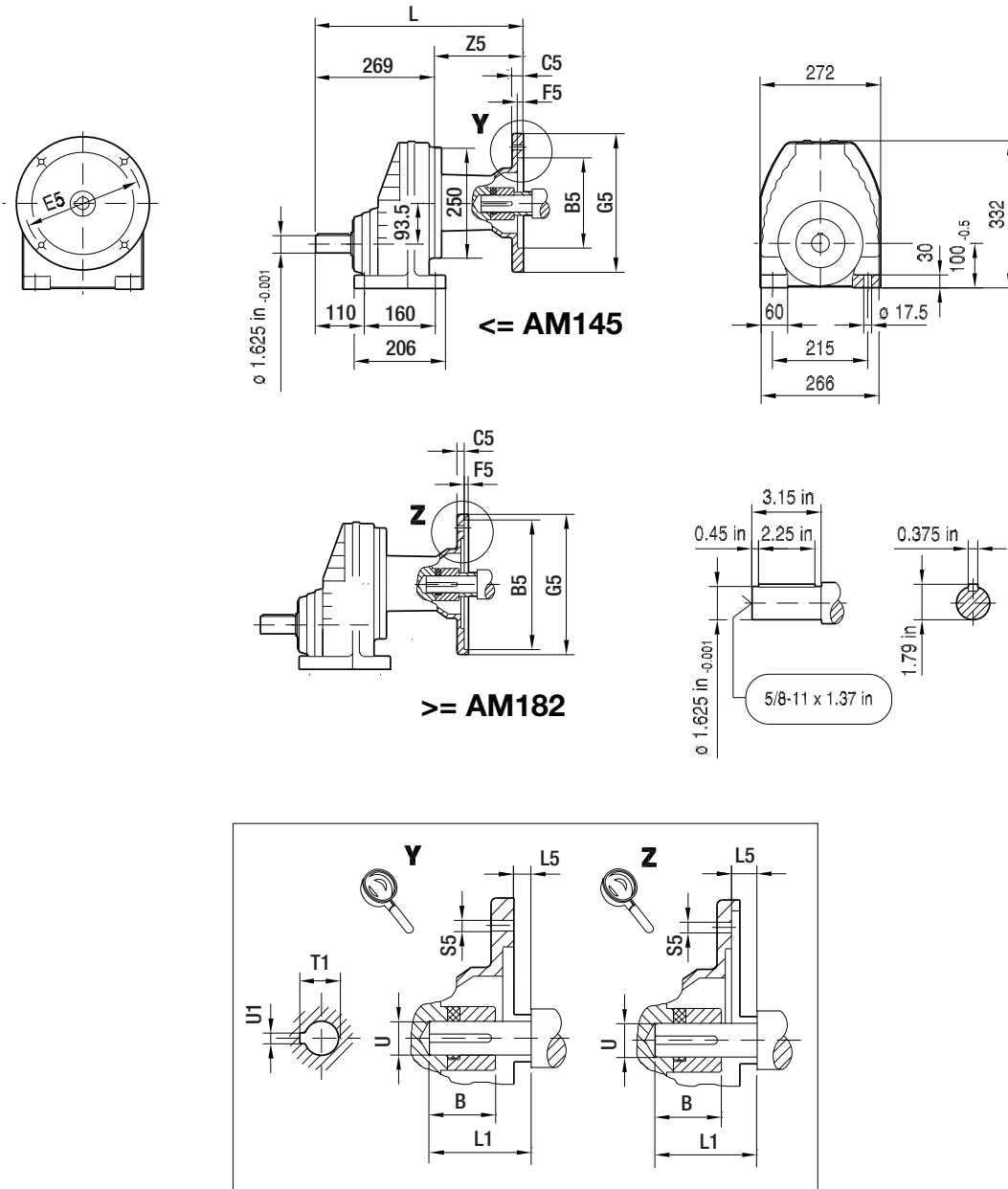



(→ 132)	B	B5	C5	E5	F5	G5	L	L1	L5	S5	T1	U	U1	Z5
AM143	1.68 in	4.50 in	12	5.875 in	4.5	170	368	2.25 in	0.13 in	10.5	0.98 in	0.875 in	0.188 in	98.5
AM145	1.68 in	4.50 in	12	5.875 in	4.5	170	368	2.25 in	0.13 in	10.5	0.98 in	0.875 in	0.188 in	98.5
AM182	2.10 in	8.50 in	10	7.25 in	5	228	404	2.75 in	0.13 in	15	1.24 in	1.125 in	0.250 in	134.5
AM184	2.10 in	8.50 in	10	7.25 in	5	228	404	2.75 in	0.13 in	15	1.24 in	1.125 in	0.250 in	134.5
AM213/215	2.76 in	8.50 in	11	7.25 in	5	228	453	3.38 in	0.25 in	15	1.52 in	1.375 in	0.312 in	183.5
AM254/256	3.65 in	8.50 in	14	7.25 in	5	228	503	4.00 in	0.25 in	15	1.80 in	1.625 in	0.375 in	234
AM284/286	4.00 in	10.50 in	15	9.00 in	5	286	510	4.62 in	0.25 in	15	2.10 in	1.875 in	0.500 in	241

Dimensions in mm unless otherwise noted. For all available output shaft diameters, see page 274.

01 016 00 11

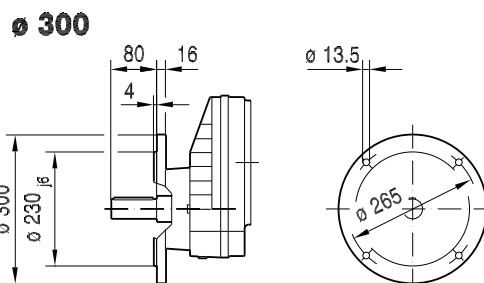
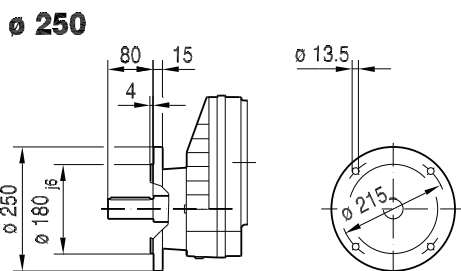
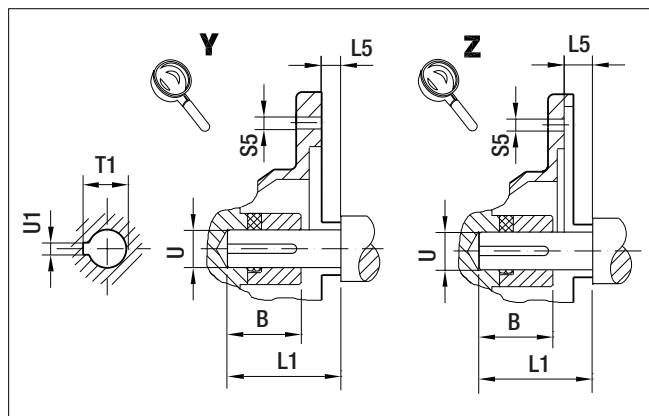
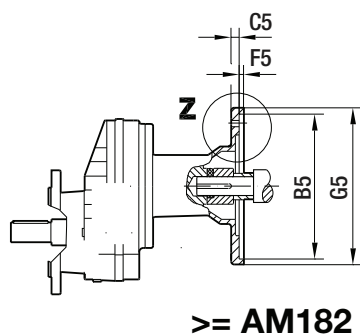
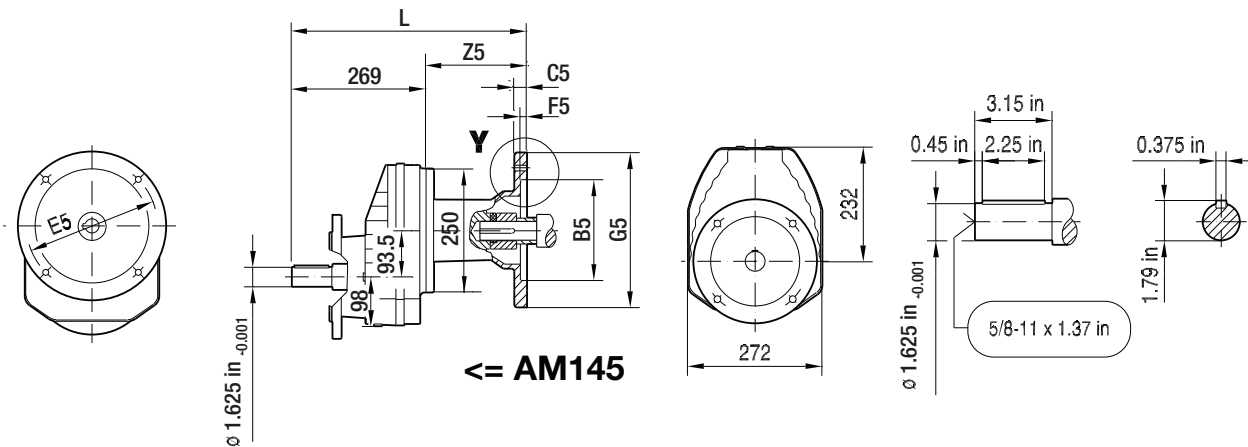
RXF87..



(→  132)	B	B5	C5	E5	F5	G5	L	L1	L5	S5	T1	U	U1	Z5
AM143	1.68 in	4.50 in	12	5.875 in	4.5	170	368	2.25 in	0.13 in	10.5	0.98 in	0.875 in	0.188 in	98.5
AM145	1.68 in	4.50 in	12	5.875 in	4.5	170	368	2.25 in	0.13 in	10.5	0.98 in	0.875 in	0.188 in	98.5
AM182	2.10 in	8.50 in	10	7.25 in	5	228	404	2.75 in	0.13 in	15	1.24 in	1.125 in	0.250 in	134.5
AM184	2.10 in	8.50 in	10	7.25 in	5	228	404	2.75 in	0.13 in	15	1.24 in	1.125 in	0.250 in	134.5
AM213/215	2.76 in	8.50 in	11	7.25 in	5	228	453	3.38 in	0.25 in	15	1.52 in	1.375 in	0.312 in	183.5
AM254/256	3.65 in	8.50 in	14	7.25 in	5	228	503	4.00 in	0.25 in	15	1.80 in	1.625 in	0.375 in	234
AM284/286	4.00 in	10.50 in	15	9.00 in	5	286	510	4.62 in	0.25 in	15	2.10 in	1.875 in	0.500 in	241

Dimensions in mm unless otherwise noted. For all available output shaft diameters, see page 274.

01 018 00 11

RXF97..

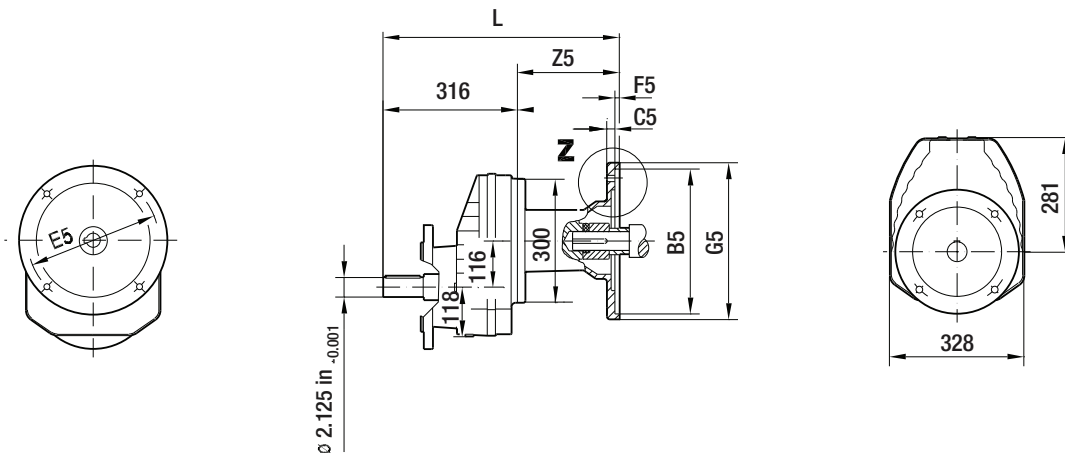

8

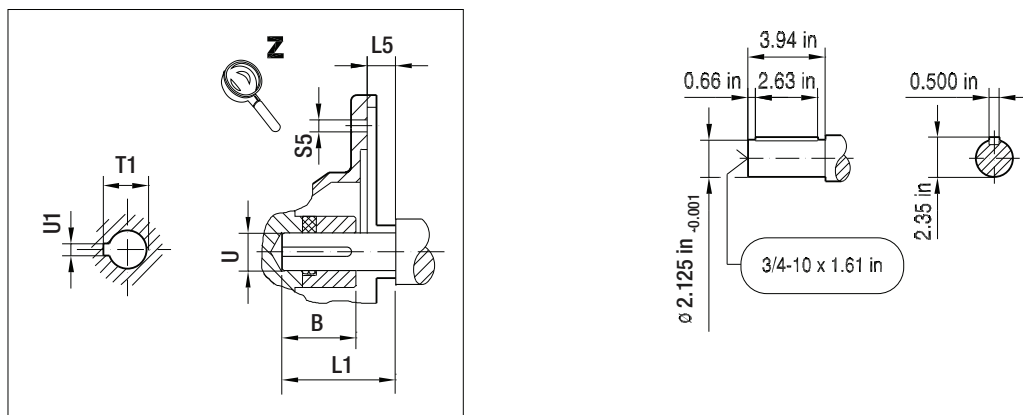

ø 300

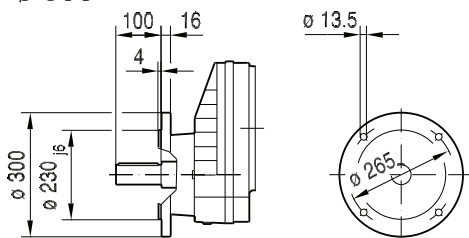

ø 350

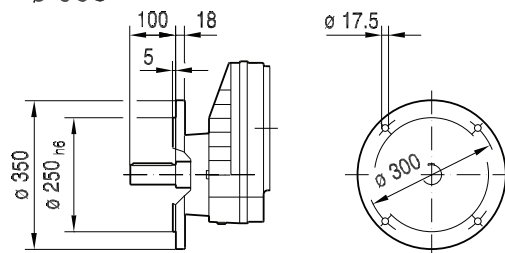

(→ 132)	B	B5	C5	E5	F5	G5	L	L1	L5	S5	T1	U	U1	Z5
AM182	2.10 in	8.50 in	10	7.25 in	5	228	446	2.75 in	0.13 in	15	1.24 in	1.125 in	0.250 in	129.5
AM184	2.10 in	8.50 in	10	7.25 in	5	228	446	2.75 in	0.13 in	15	1.24 in	1.125 in	0.250 in	129.5
AM213/215	2.76 in	8.50 in	11	7.25 in	5	228	495	3.38 in	0.25 in	15	1.52 in	1.375 in	0.312 in	178.5
AM254/256	3.65 in	8.50 in	12	7.25 in	5	228	545	4.00 in	0.25 in	15	1.80 in	1.625 in	0.375 in	229
AM284/286	4.00 in	10.5 in	15	9.00 in	5	286	552	4.62 in	0.25 in	15	2.10 in	1.875 in	0.500 in	236
AM324/326	3.88 in	12.5 in	17	11.0 in	5	356	612	5.25 in	0.25 in	17.5	2.36 in	2.125 in	0.500 in	296
AM364/365	4.51 in	12.5 in	17	11.0 in	5	356	612	5.88 in	0.25 in	17.5	2.66 in	2.375 in	0.625 in	296

Dimensions in mm unless otherwise noted. For all available output shaft diameters, see page 274.

RX107..

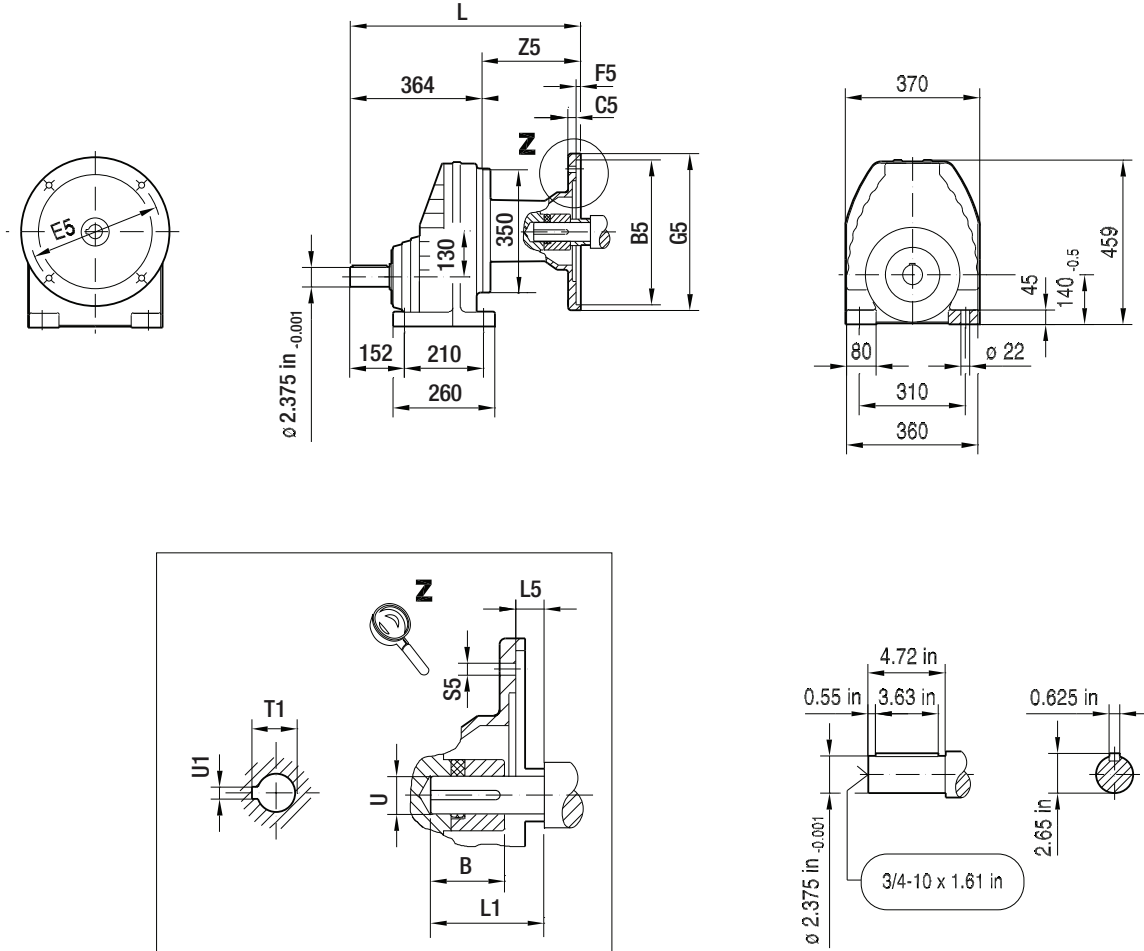

(→ 132)	B	B5	C5	E5	F5	G5	L	L1	L5	S5	T1	U	U1	Z5
AM182	2.10 in	8.50 in	10	7.25 in	5	228	488	2.75 in	0.13 in	15	1.24 in	1.125 in	0.250 in	123.5
AM184	2.10 in	8.50 in	10	7.25 in	5	228	488	2.75 in	0.13 in	15	1.24 in	1.125 in	0.250 in	123.5
AM213/215	2.76 in	8.50 in	11	7.25 in	5	228	537	3.38 in	0.25 in	15	1.52 in	1.375 in	0.312 in	172.5
AM254/256	3.65 in	8.50 in	12	7.25 in	5	228	587	4.00 in	0.25 in	15	1.80 in	1.625 in	0.375 in	223
AM284/286	4.00 in	10.5 in	15	9.00 in	5	286	594	4.62 in	0.25 in	15	2.10 in	1.875 in	0.500 in	230
AM324/326	3.88 in	12.5 in	17	11.0 in	5	356	654	5.25 in	0.25 in	17.5	2.36 in	2.125 in	0.500 in	290
AM364/365	4.51 in	12.5 in	17	11.0 in	5	356	654	5.88 in	0.25 in	17.5	2.66 in	2.375 in	0.625 in	290

Dimensions in mm unless otherwise noted. For all available output shaft diameters, see page 274.

01 020 00 11

RXF107..

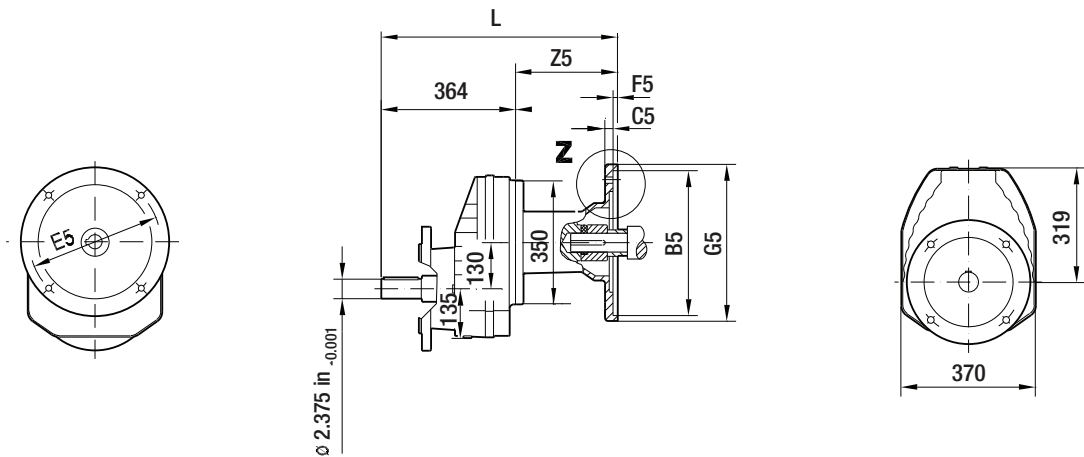

8

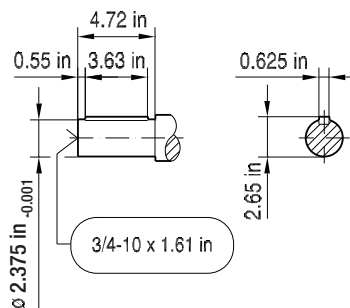
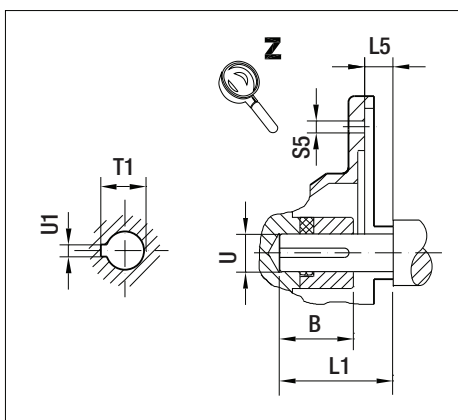

ø 350

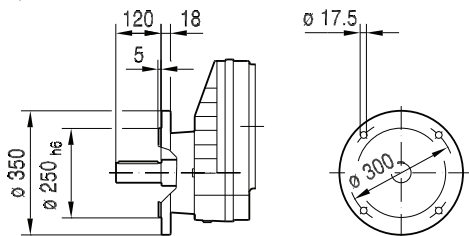

ø 450

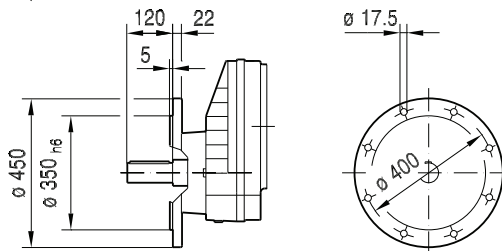

(→  132)	B	B5	C5	E5	F5	G5	L	L1	L5	S5	T1	U	U1	Z5
AM182	2.10 in	8.50 in	10	7.25 in	5	228	488	2.75 in	0.13 in	15	1.24 in	1.125 in	0.250 in	123.5
AM184	2.10 in	8.50 in	10	7.25 in	5	228	488	2.75 in	0.13 in	15	1.24 in	1.125 in	0.250 in	123.5
AM213/215	2.76 in	8.50 in	11	7.25 in	5	228	537	3.38 in	0.25 in	15	1.52 in	1.375 in	0.312 in	172.5
AM254/256	3.65 in	8.50 in	12	7.25 in	5	228	587	4.00 in	0.25 in	15	1.80 in	1.625 in	0.375 in	223
AM284/286	4.00 in	10.50 in	15	9.00 in	5	286	594	4.62 in	0.25 in	15	2.10 in	1.875 in	0.500 in	230
AM324/326	3.88 in	12.50 in	17	11.0 in	5	356	654	5.25 in	0.25 in	17.5	2.36 in	2.125 in	0.500 in	290
AM364/365	4.51 in	12.50 in	17	11.0 in	5	356	654	5.88 in	0.25 in	17.5	2.66 in	2.375 in	0.625 in	290

Dimensions in mm unless otherwise noted. For all available output shaft diameters, see page 274.

01 021 00 11

R27..

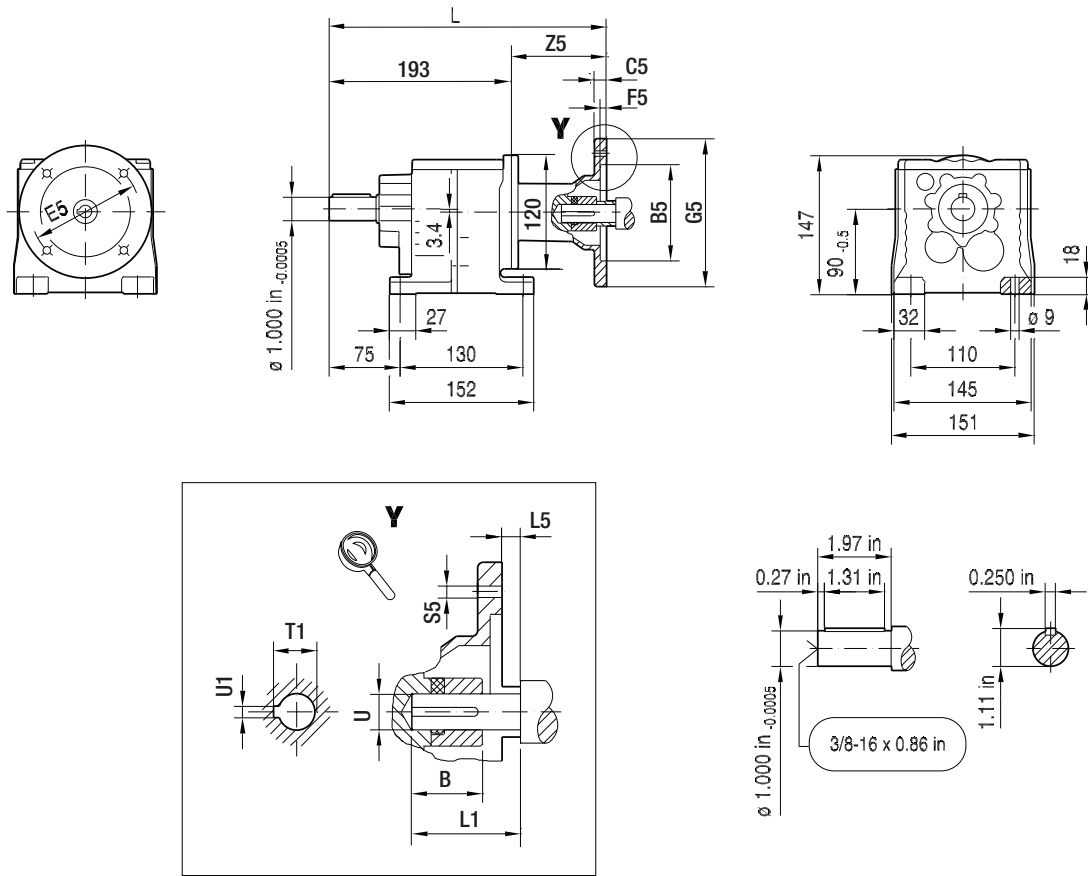

R27F..

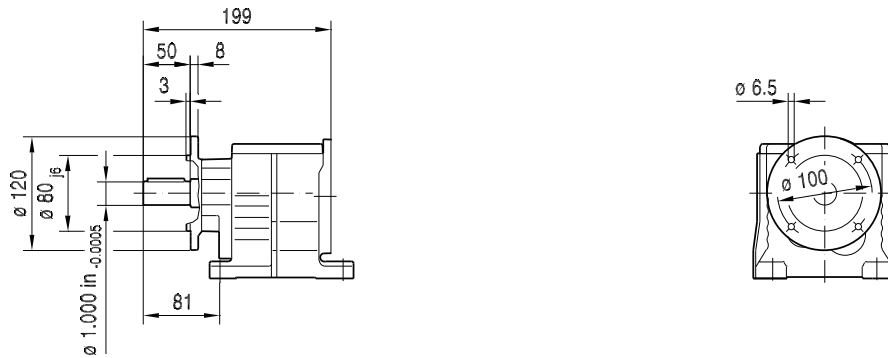

(→ 132)	B	B5	C5	E5	F5	G5	L	L1	L5	S5	T1	U	U1	Z5
AM56	1.23 in	4.50 in	11	5.875 in	4.5	170	287	1.88 in	-0.18 in	10.5	0.71 in	0.625 in	0.188 in	93.5
AM143	1.68 in	4.50 in	12	5.875 in	4.5	170	310	2.25 in	0.13 in	10.5	0.98 in	0.875 in	0.188 in	117
AM145	1.68 in	4.50 in	12	5.875 in	4.5	170	310	2.25 in	0.13 in	10.5	0.98 in	0.875 in	0.188 in	117

Dimensions in mm unless otherwise noted. For all available output shaft diameters, see page 274.

01 022 00 11

RF27..

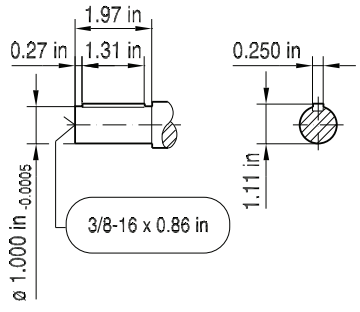
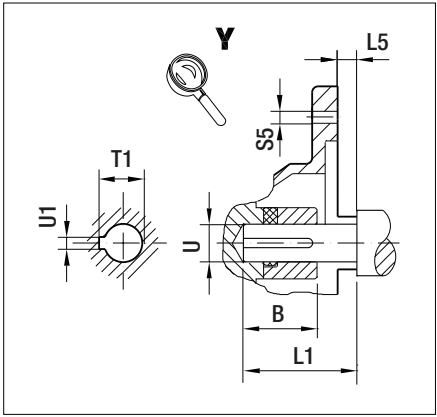
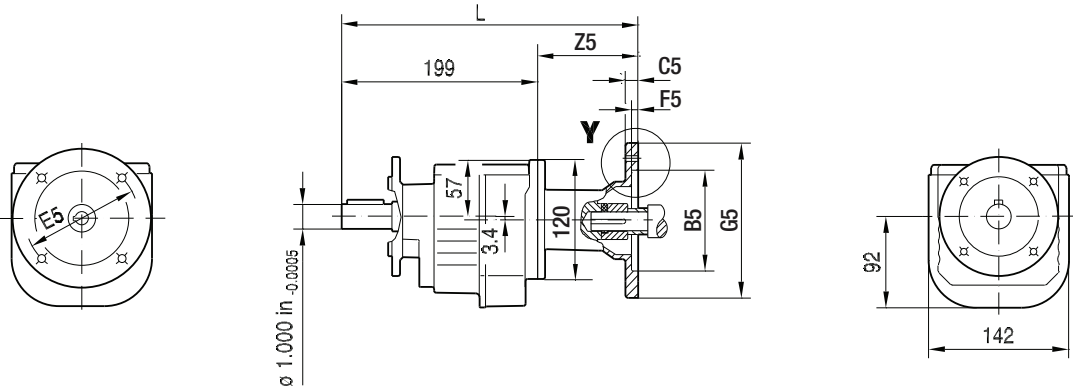

ø 120

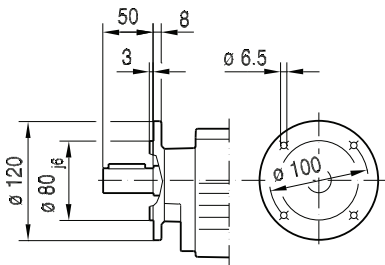

ø 140

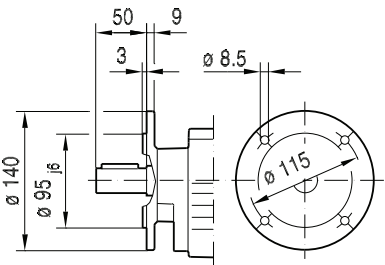

ø 160

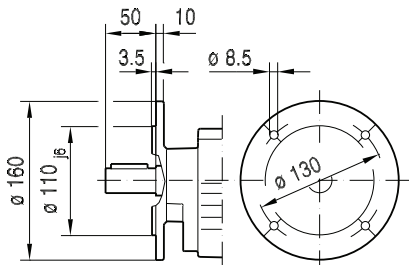

(→ 132)	B	B5	C5	E5	F5	G5	L	L1	L5	S5	T1	U	U1	Z5
AM56	1.23 in	4.50 in	11	5.875 in	4.5	170	293	1.88 in	-0.18 in	10.5	0.71 in	0.625 in	0.188 in	93.5
AM143	1.68 in	4.50 in	12	5.875 in	4.5	170	316	2.25 in	0.13 in	10.5	0.98 in	0.875 in	0.188 in	117
AM145	1.68 in	4.50 in	12	5.875 in	4.5	170	316	2.25 in	0.13 in	10.5	0.98 in	0.875 in	0.188 in	117

Dimensions in mm unless otherwise noted. For all available output shaft diameters, see page 274.

RZ27..

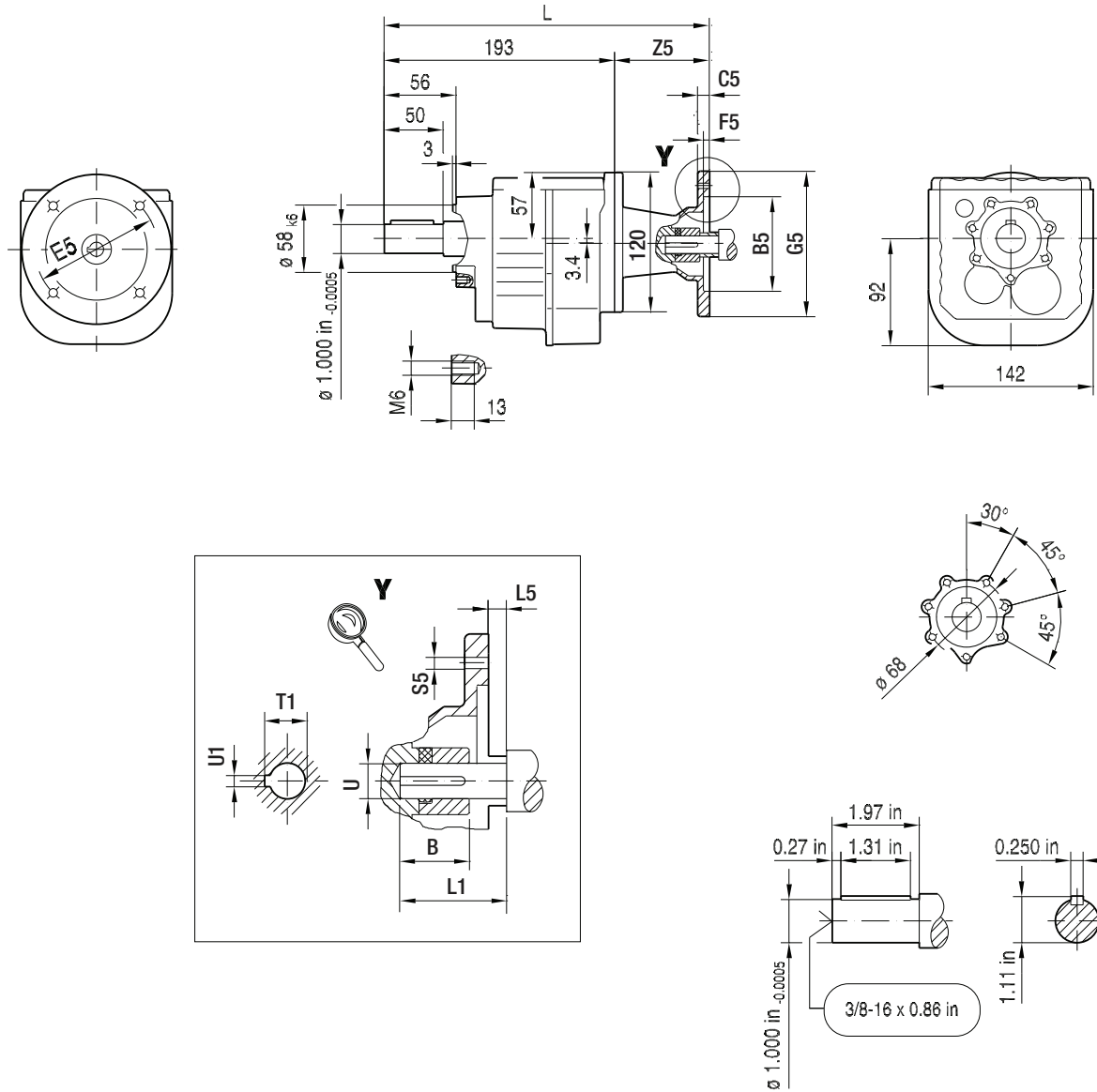

(→ 132)	B	B5	C5	E5	F5	G5	L	L1	L5	S5	T1	U	U1	Z5
AM56	1.23 in	4.50 in	11	5.875 in	4.5	170	287	1.88 in	-0.18 in	10.5	0.71 in	0.625 in	0.188 in	93.5
AM143	1.68 in	4.50 in	12	5.875 in	4.5	170	310	2.25 in	0.13 in	10.5	0.98 in	0.875 in	0.188 in	117
AM145	1.68 in	4.50 in	12	5.875 in	4.5	170	310	2.25 in	0.13 in	10.5	0.98 in	0.875 in	0.188 in	117

Dimensions in mm unless otherwise noted. For all available output shaft diameters, see page 274.

01 024 00 11

R37..

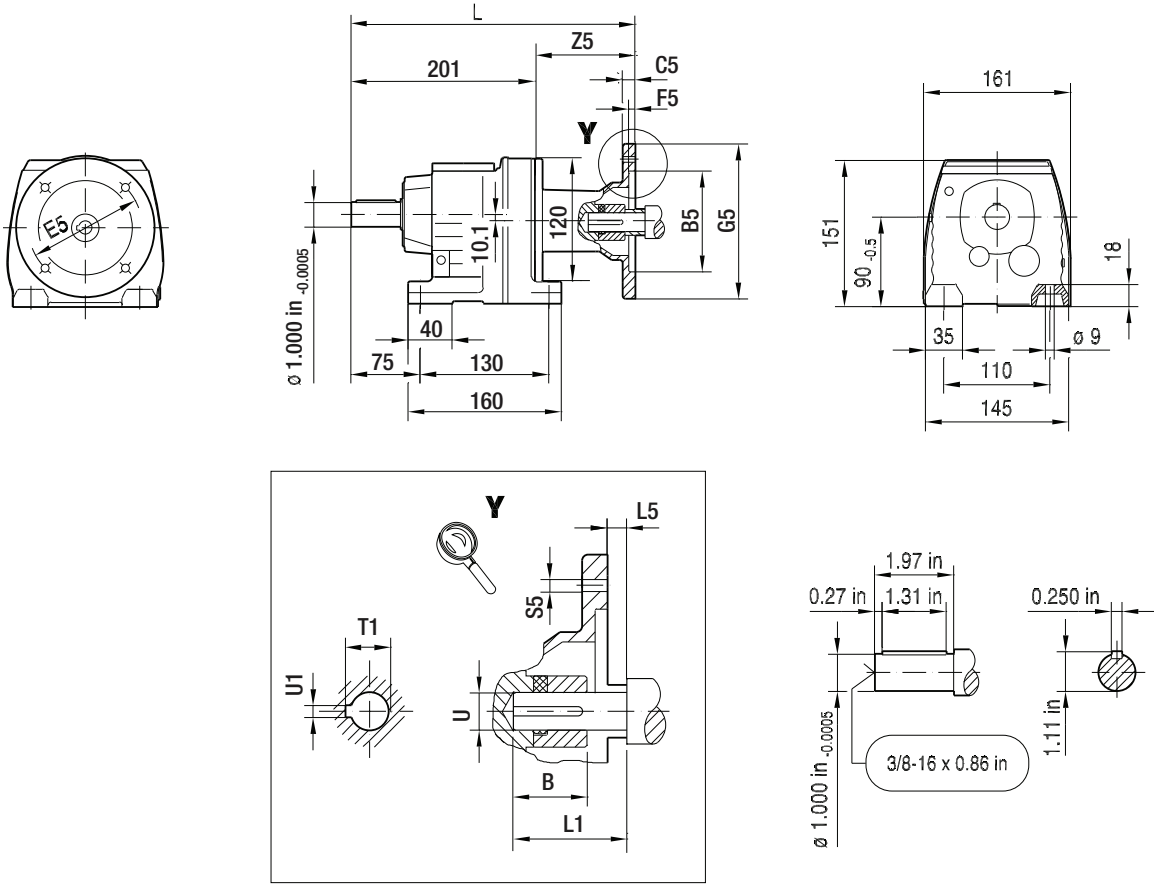

8

R37F..

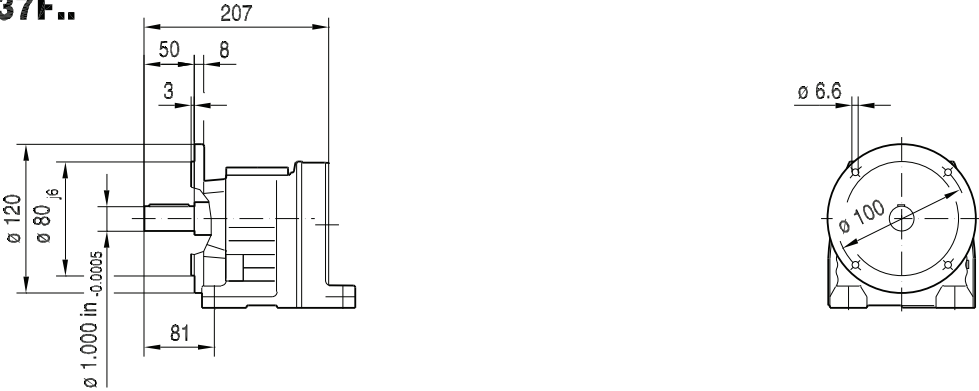

(→ 132)	B	B5	C5	E5	F5	G5	L	L1	L5	S5	T1	U	U1	Z5
AM56	1.23 in	4.50 in	11	5.875 in	4.5	170	295	1.88 in	-0.18 in	10.5	0.71 in	0.625 in	0.188 in	93.5
AM143	1.68 in	4.50 in	12	5.875 in	4.5	170	318	2.25 in	0.13 in	10.5	0.98 in	0.875 in	0.188 in	117
AM145	1.68 in	4.50 in	12	5.875 in	4.5	170	318	2.25 in	0.13 in	10.5	0.98 in	0.875 in	0.188 in	117

Dimensions in mm unless otherwise noted. For all available output shaft diameters, see page 274.

01 025 00 11

RF37..

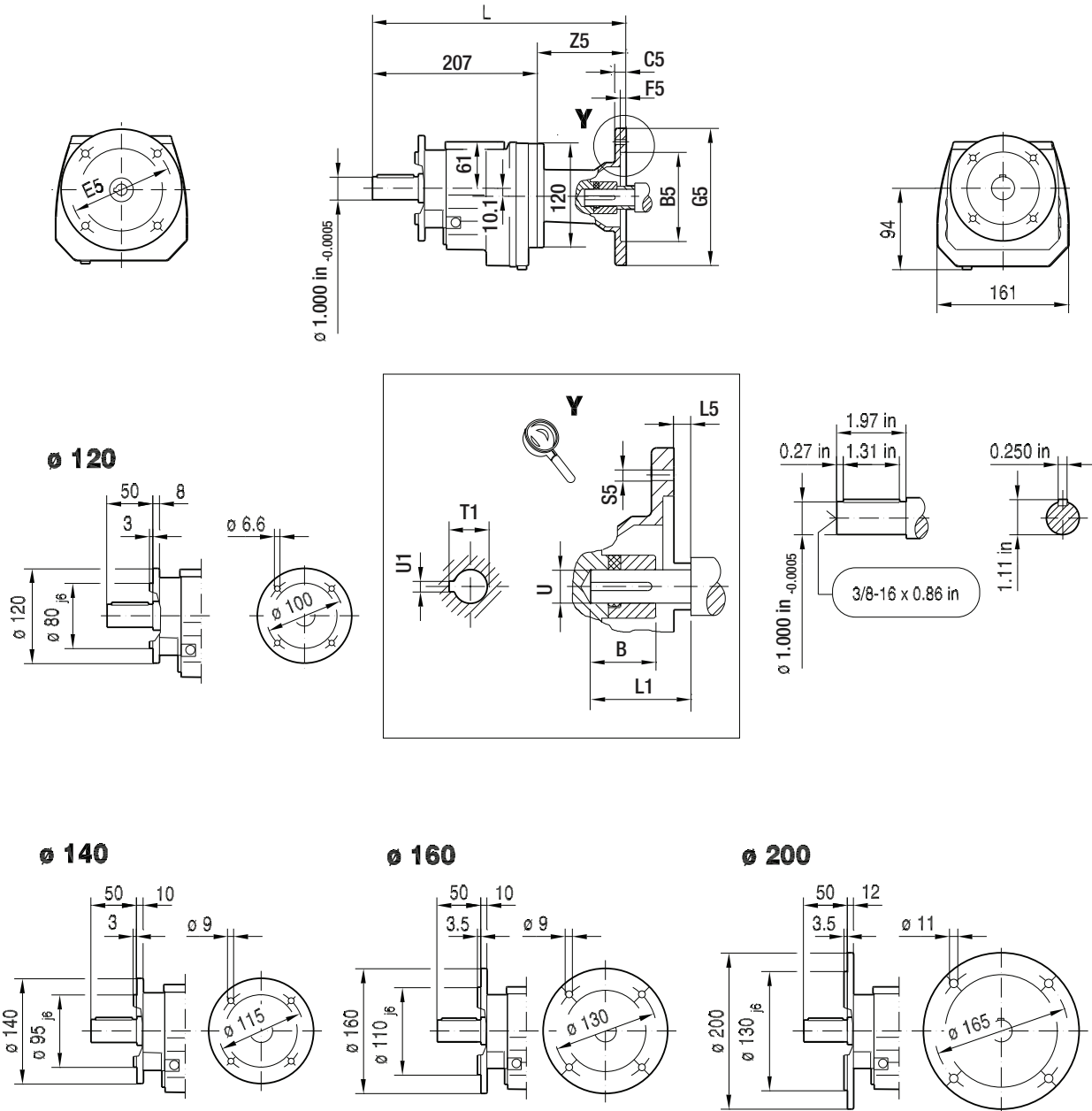

(→ 132)	B	B5	C5	E5	F5	G5	L	L1	L5	S5	T1	U	U1	Z5
AM56	1.23 in	4.50 in	11	5.875 in	4.5	170	301	1.88 in	-0.18 in	10.5	0.71 in	0.625 in	0.188 in	93.5
AM143	1.68 in	4.50 in	12	5.875 in	4.5	170	324	2.25 in	0.13 in	10.5	0.98 in	0.875 in	0.188 in	117
AM145	1.68 in	4.50 in	12	5.875 in	4.5	170	324	2.25 in	0.13 in	10.5	0.98 in	0.875 in	0.188 in	117

Dimensions in mm unless otherwise noted. For all available output shaft diameters, see page 274.

RZ37..

01 026 00 11

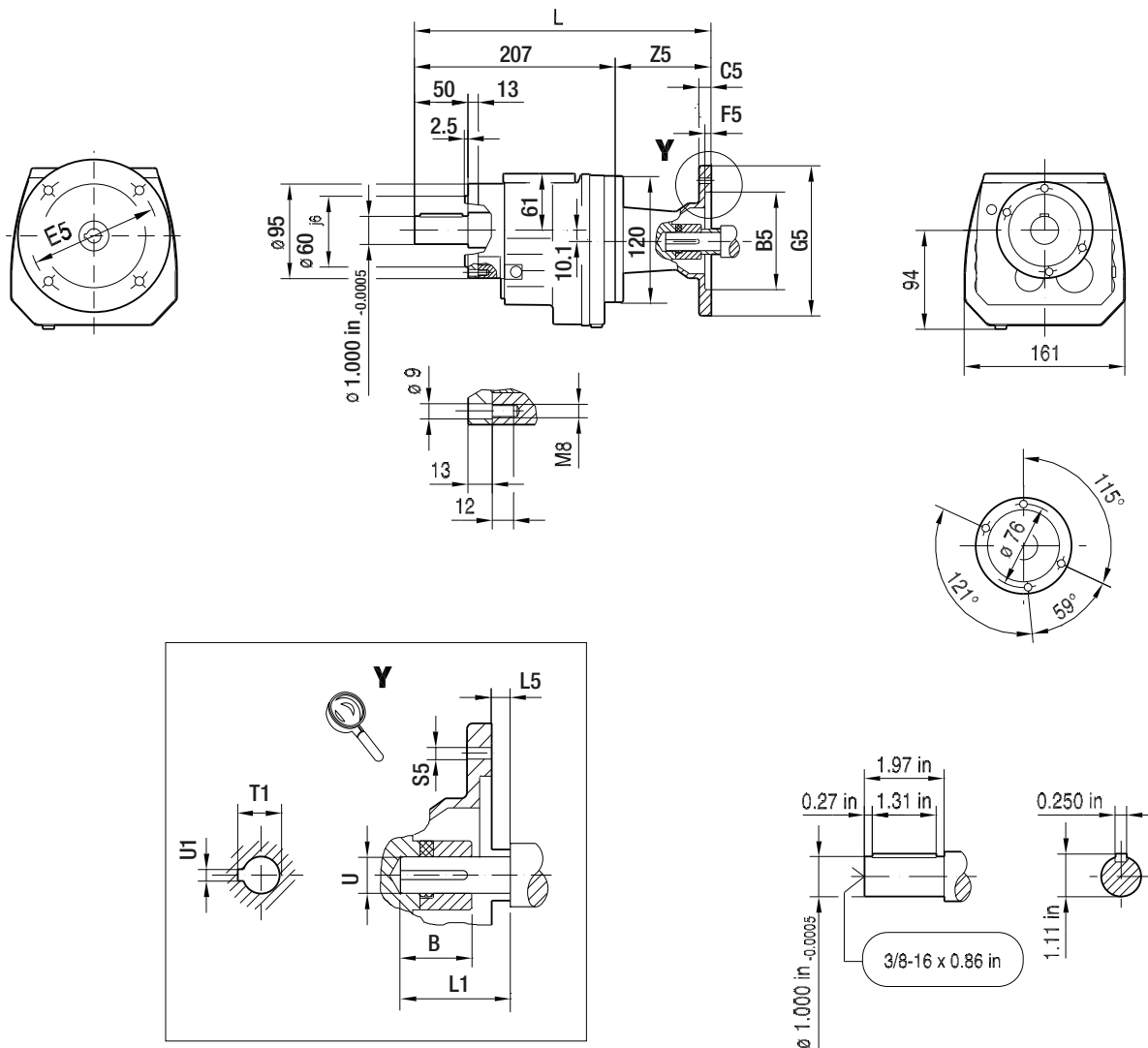

8

(→ 132)	B	B5	C5	E5	F5	G5	L	L1	L5	S5	T1	U	U1	Z5
AM56	1.23 in	4.50 in	11	5.875 in	4.5	170	301	1.88 in	-0.18 in	10.5	0.71 in	0.625 in	0.188 in	93.5
AM143	1.68 in	4.50 in	12	5.875 in	4.5	170	324	2.25 in	0.13 in	10.5	0.98 in	0.875 in	0.188 in	117
AM145	1.68 in	4.50 in	12	5.875 in	4.5	170	324	2.25 in	0.13 in	10.5	0.98 in	0.875 in	0.188 in	117

Dimensions in mm unless otherwise noted. For all available output shaft diameters, see page 274.

01 028 00 11

RF47..

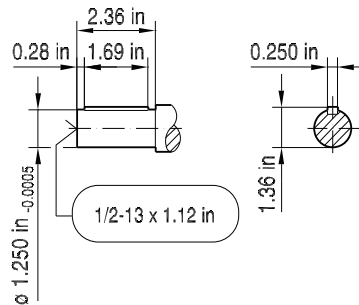
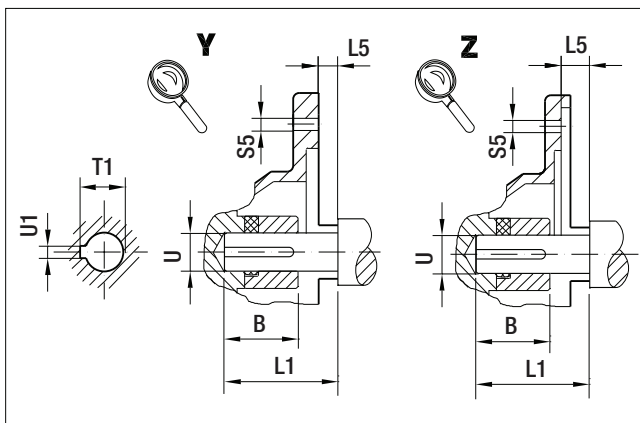
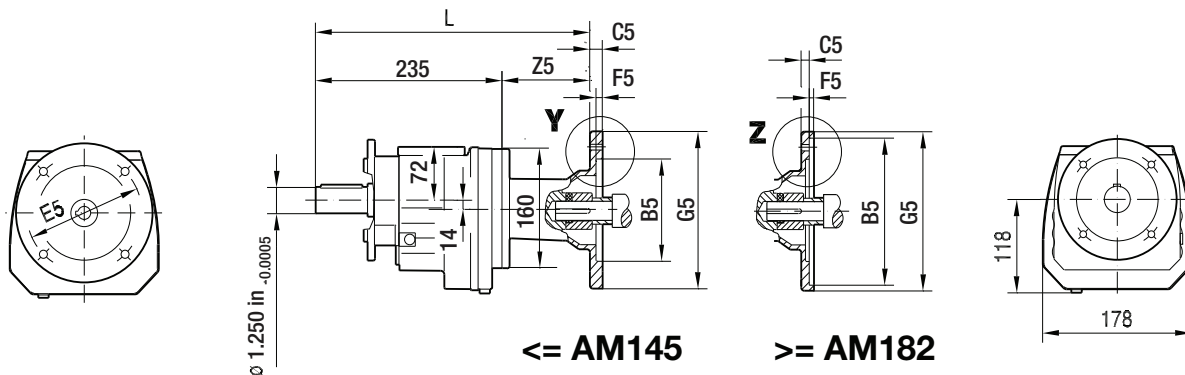

ø 140

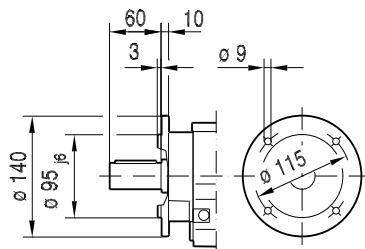

ø 160

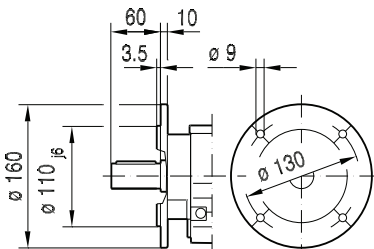

ø 200

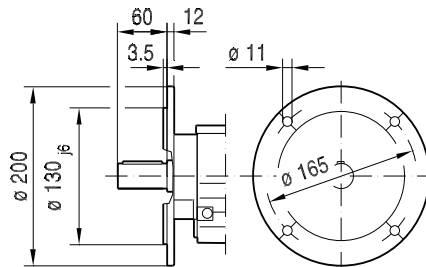

(→ 132)	B	B5	C5	E5	F5	G5	L	L1	L5	S5	T1	U	U1	Z5
AM56	1.23 in	4.50 in	11	5.875 in	4.5	170	322	1.88 in	-0.18 in	10.5	0.71 in	0.625 in	0.188 in	87
AM143	1.68 in	4.50 in	12	5.875 in	4.5	170	346	2.25 in	0.13 in	10.5	0.98 in	0.875 in	0.188 in	110.5
AM145	1.68 in	4.50 in	12	5.875 in	4.5	170	346	2.25 in	0.13 in	10.5	0.98 in	0.875 in	0.188 in	110.5
AM182	2.10 in	8.50 in	10	7.25 in	5	228	383	2.75 in	0.13 in	15	1.24 in	1.125 in	0.250 in	147.5
AM184	2.10 in	8.50 in	10	7.25 in	5	228	383	2.75 in	0.13 in	15	1.24 in	1.125 in	0.250 in	147.5
AM213/215	2.76 in	8.50 in	11	7.25 in	5	228	436	3.38 in	0.25 in	15	1.52 in	1.375 in	0.312 in	200.5

Note: Dimensions in mm unless otherwise noted. For all available output shaft diameters, see page 274. For dimensions of compound gear units (ex: RF47R37) see page 269.

RZ47..

01 029 00 11

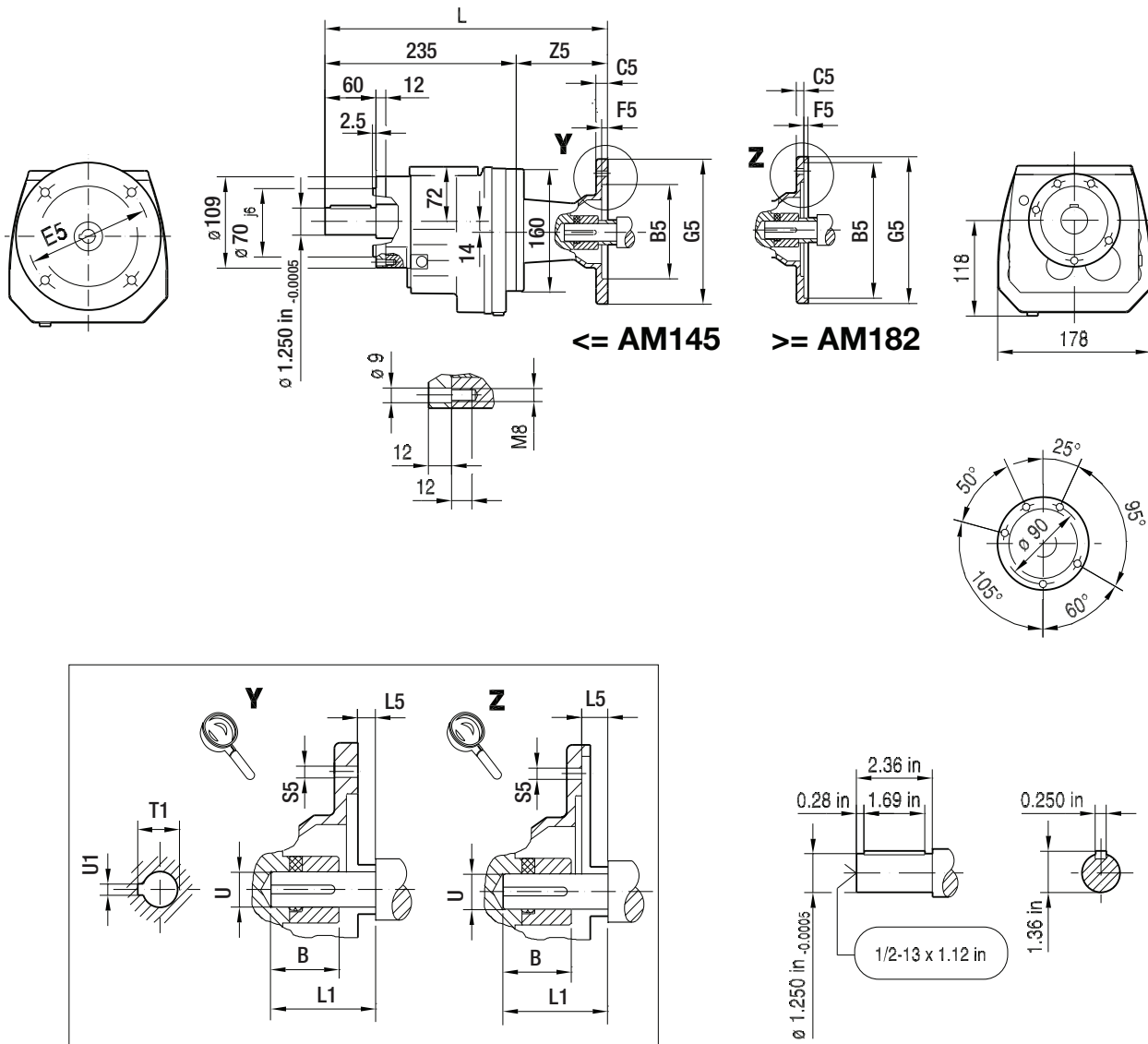

(→ 132)	B	B5	C5	E5	F5	G5	L	L1	L5	S5	T1	U	U1	Z5
AM56	1.23 in	4.50 in	11	5.875 in	4.5	170	322	1.88 in	-0.18 in	10.5	0.71 in	0.625 in	0.188 in	87
AM143	1.68 in	4.50 in	12	5.875 in	4.5	170	346	2.25 in	0.13 in	10.5	0.98 in	0.875 in	0.188 in	110.5
AM145	1.68 in	4.50 in	12	5.875 in	4.5	170	346	2.25 in	0.13 in	10.5	0.98 in	0.875 in	0.188 in	110.5
AM182	2.10 in	8.50 in	10	7.25 in	5	228	383	2.75 in	0.13 in	15	1.24 in	1.125 in	0.250 in	147.5
AM184	2.10 in	8.50 in	10	7.25 in	5	228	383	2.75 in	0.13 in	15	1.24 in	1.125 in	0.250 in	147.5
AM213/215	2.76 in	8.50 in	11	7.25 in	5	228	436	3.38 in	0.25 in	15	1.52 in	1.375 in	0.312 in	200.5

Note: Dimensions in mm unless otherwise noted. For all available output shaft diameters, see page 274. For dimensions of compound gear units (ex: RZ47R37) see page 269.

01 030 00 11

R57..

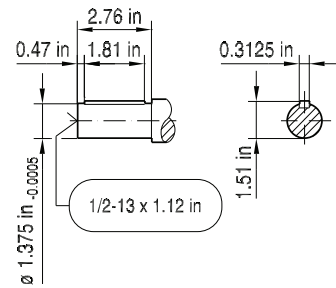
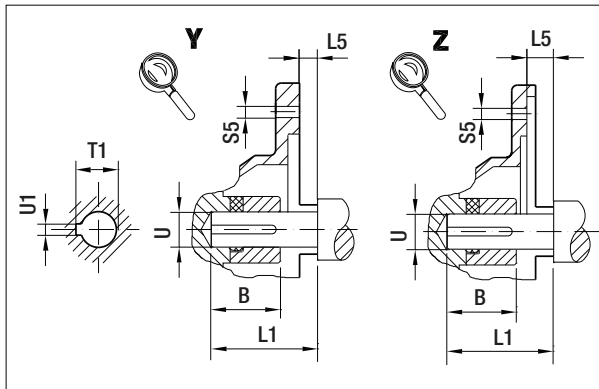
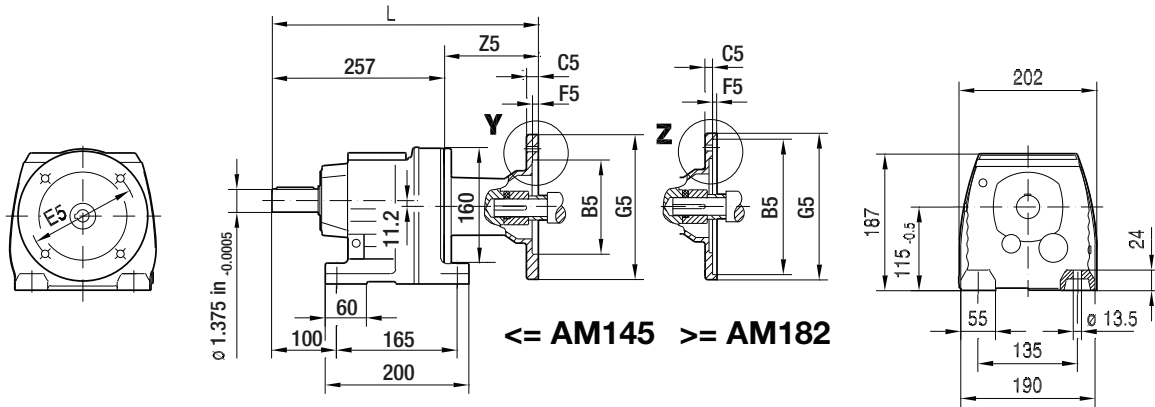

R57F..

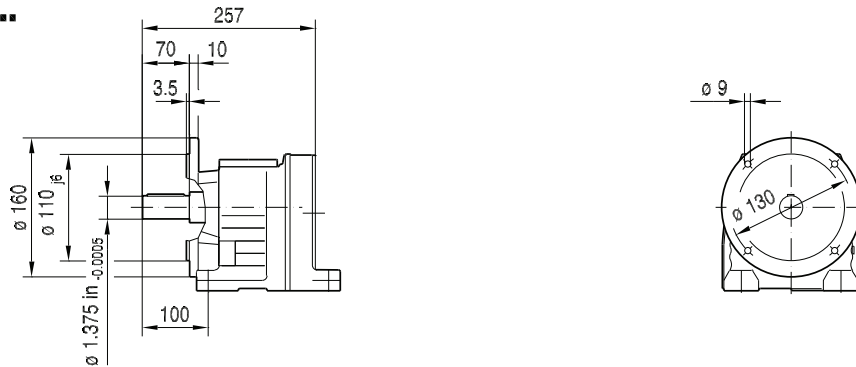

(→ 132)	B	B5	C5	E5	F5	G5	L	L1	L5	S5	T1	U	U1	Z5
AM56	1.23 in	4.50 in	11	5.875 in	4.5	170	344	1.88 in	-0.18 in	10.5	0.71 in	0.625 in	0.188 in	87
AM143	1.68 in	4.50 in	12	5.875 in	4.5	170	368	2.25 in	0.13 in	10.5	0.98 in	0.875 in	0.188 in	110.5
AM145	1.68 in	4.50 in	12	5.875 in	4.5	170	368	2.25 in	0.13 in	10.5	0.98 in	0.875 in	0.188 in	110.5
AM182	2.10 in	8.50 in	10	7.25 in	5	228	405	2.75 in	0.13 in	15	1.24 in	1.125 in	0.250 in	147.5
AM184	2.10 in	8.50 in	10	7.25 in	5	228	405	2.75 in	0.13 in	15	1.24 in	1.125 in	0.250 in	147.5
AM213/215	2.76 in	8.50 in	11	7.25 in	5	228	458	3.38 in	0.25 in	15	1.52 in	1.375 in	0.312 in	200.5

Note: Dimensions in mm unless otherwise noted. For all available output shaft diameters, see page 274. For dimensions of compound gear units (ex: R57R37) see page 269.

RZ57..

01 032 00 11

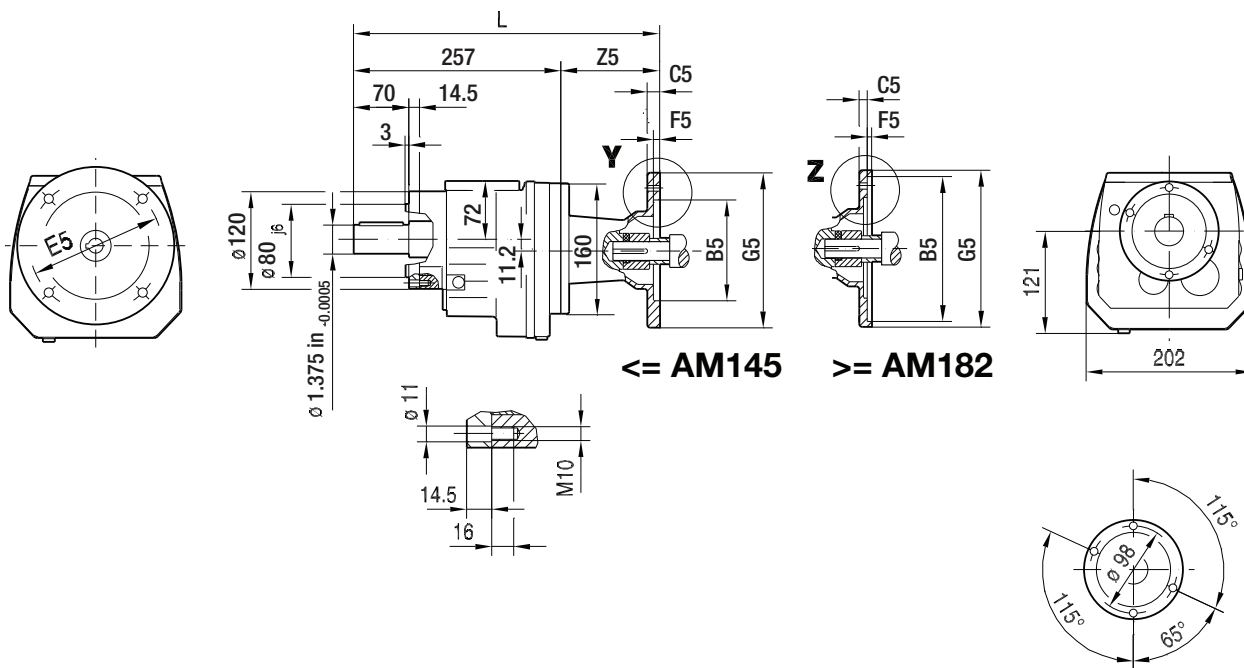

8

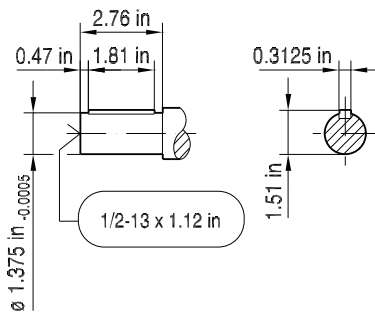
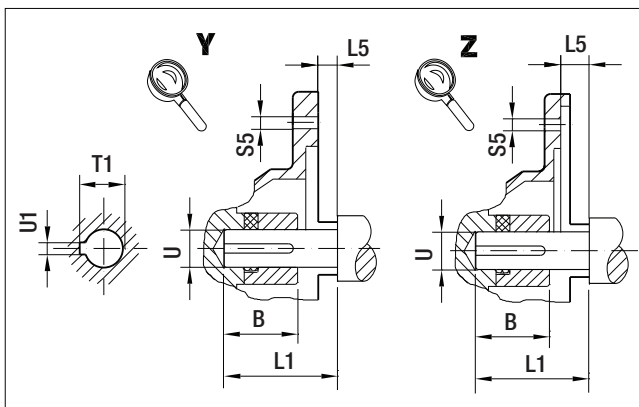

(→ 132)	B	B5	C5	E5	F5	G5	L	L1	L5	S5	T1	U	U1	Z5
AM56	1.23 in	4.50 in	11	5.875 in	4.5	170	344	1.88 in	-0.18 in	10.5	0.71 in	0.625 in	0.188 in	87
AM143	1.68 in	4.50 in	12	5.875 in	4.5	170	368	2.25 in	0.13 in	10.5	0.98 in	0.875 in	0.188 in	110.5
AM145	1.68 in	4.50 in	12	5.875 in	4.5	170	368	2.25 in	0.13 in	10.5	0.98 in	0.875 in	0.188 in	110.5
AM182	2.10 in	8.50 in	10	7.25 in	5	228	405	2.75 in	0.13 in	15	1.24 in	1.125 in	0.250 in	147.5
AM184	2.10 in	8.50 in	10	7.25 in	5	228	405	2.75 in	0.13 in	15	1.24 in	1.125 in	0.250 in	147.5
AM213/215	2.76 in	8.50 in	11	7.25 in	5	228	458	3.38 in	0.25 in	15	1.52 in	1.375 in	0.312 in	200.5

Note: Dimensions in mm unless otherwise noted. For all available output shaft diameters, see page 274. For dimensions of compound gear units (ex: RZ57R37) see page 269.

01 033 00 11

R67..

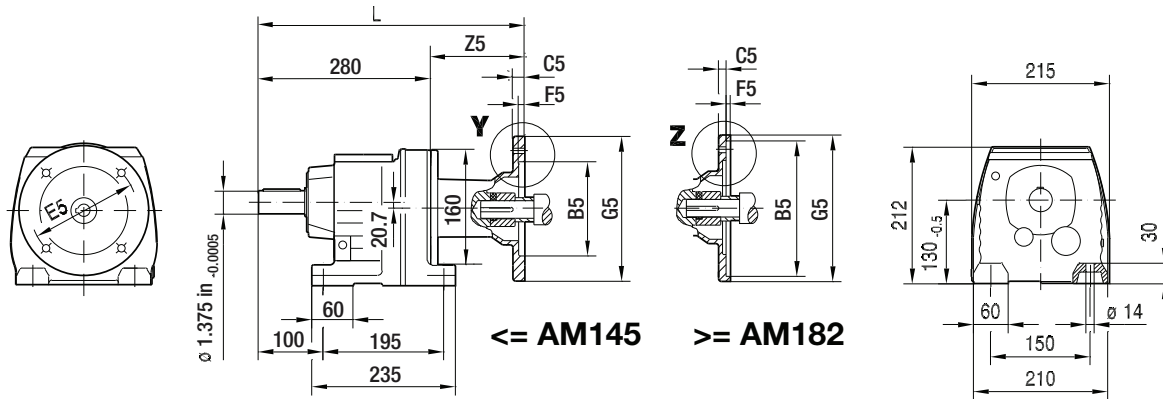

≤ AM145 ≥ AM182

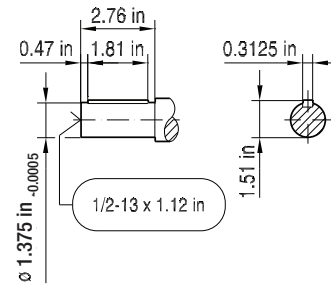
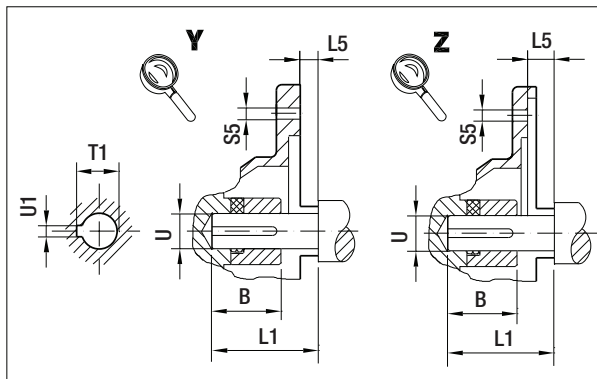

R67F..

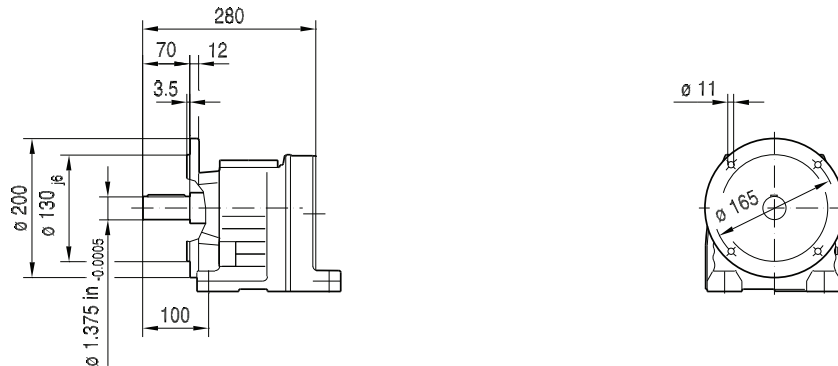

(→ 132)	B	B5	C5	E5	F5	G5	L	L1	L5	S5	T1	U	U1	Z5
AM56	1.23 in	4.50 in	11	5.875 in	4.5	170	367	1.88 in	-0.18 in	10.5	0.71 in	0.625 in	0.188 in	87
AM143	1.68 in	4.50 in	12	5.875 in	4.5	170	391	2.25 in	0.13 in	10.5	0.98 in	0.875 in	0.188 in	110.5
AM145	1.68 in	4.50 in	12	5.875 in	4.5	170	391	2.25 in	0.13 in	10.5	0.98 in	0.875 in	0.188 in	110.5
AM182	2.10 in	8.50 in	10	7.25 in	5	228	428	2.75 in	0.13 in	15	1.24 in	1.125 in	0.250 in	147.5
AM184	2.10 in	8.50 in	10	7.25 in	5	228	428	2.75 in	0.13 in	15	1.24 in	1.125 in	0.250 in	147.5
AM213/215	2.76 in	8.50 in	11	7.25 in	5	228	481	3.38 in	0.25 in	15	1.52 in	1.375 in	0.312 in	200.5

Note: Dimensions in mm unless otherwise noted. For all available output shaft diameters, see page 274. For dimensions of compound gear units (ex: R67R37) see page 269.

RF67..

01 034 00 11

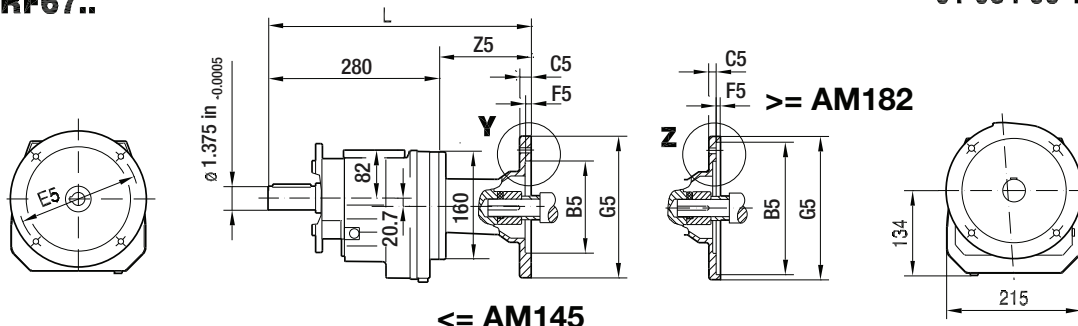

$\leq AM145$

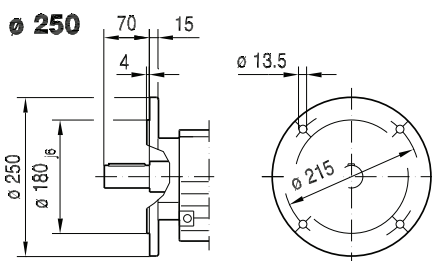
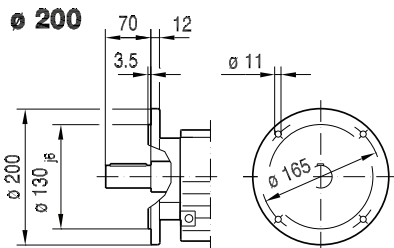
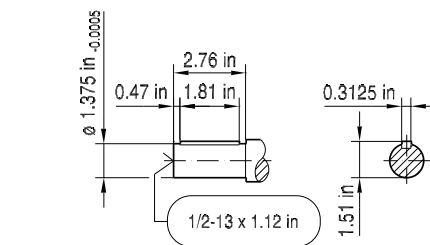
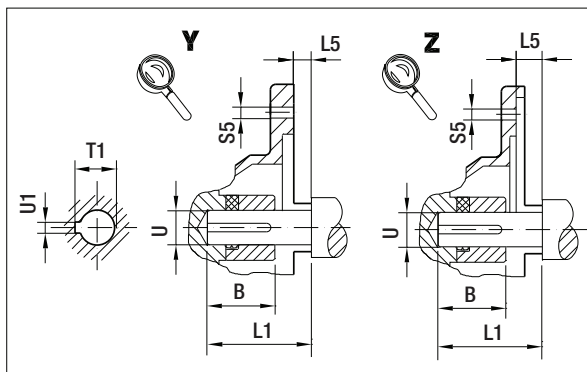

RM67..

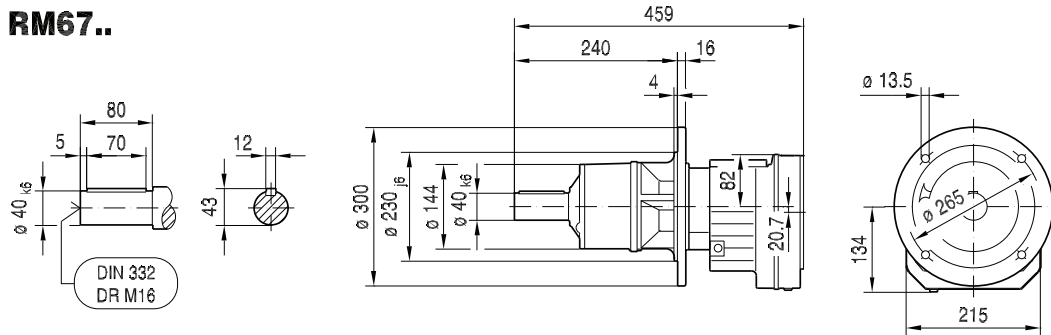

(→ 132)	B	B5	C5	E5	F5	G5	L	L1	L5	S5	T1	U	U1	Z5
AM56	1.23 in	4.50 in	11	5.875 in	4.5	170	367	1.88 in	-0.18 in	10.5	0.71 in	0.625 in	0.188 in	87
AM143	1.68 in	4.50 in	12	5.875 in	4.5	170	391	2.25 in	0.13 in	10.5	0.98 in	0.875 in	0.188 in	110.5
AM145	1.68 in	4.50 in	12	5.875 in	4.5	170	391	2.25 in	0.13 in	10.5	0.98 in	0.875 in	0.188 in	110.5
AM182	2.10 in	8.50 in	10	7.25 in	5	228	428	2.75 in	0.13 in	15	1.24 in	1.125 in	0.250 in	147.5
AM184	2.10 in	8.50 in	10	7.25 in	5	228	428	2.75 in	0.13 in	15	1.24 in	1.125 in	0.250 in	147.5
AM213/215	2.76 in	8.50 in	11	7.25 in	5	228	481	3.38 in	0.25 in	15	1.52 in	1.375 in	0.312 in	200.5

Note: Dimensions in mm unless otherwise noted. For all available output shaft diameters, see page 274. For dimensions of compound gear units (ex: RF67R37) see page 269.

01 035 00 11

RZ67..

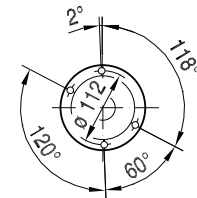
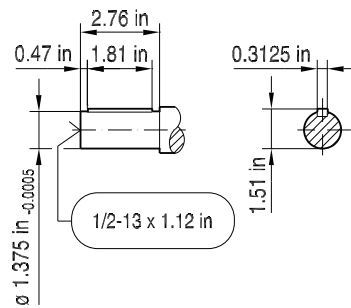
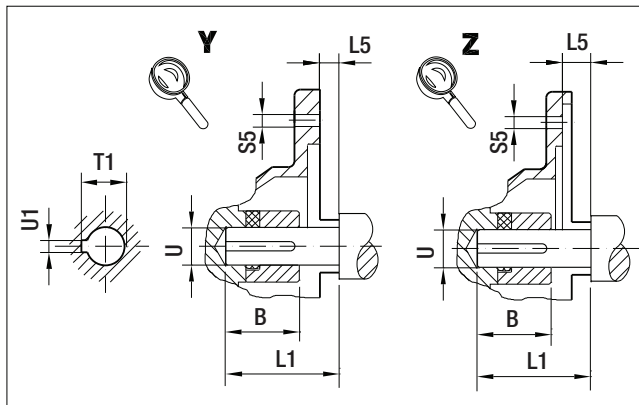
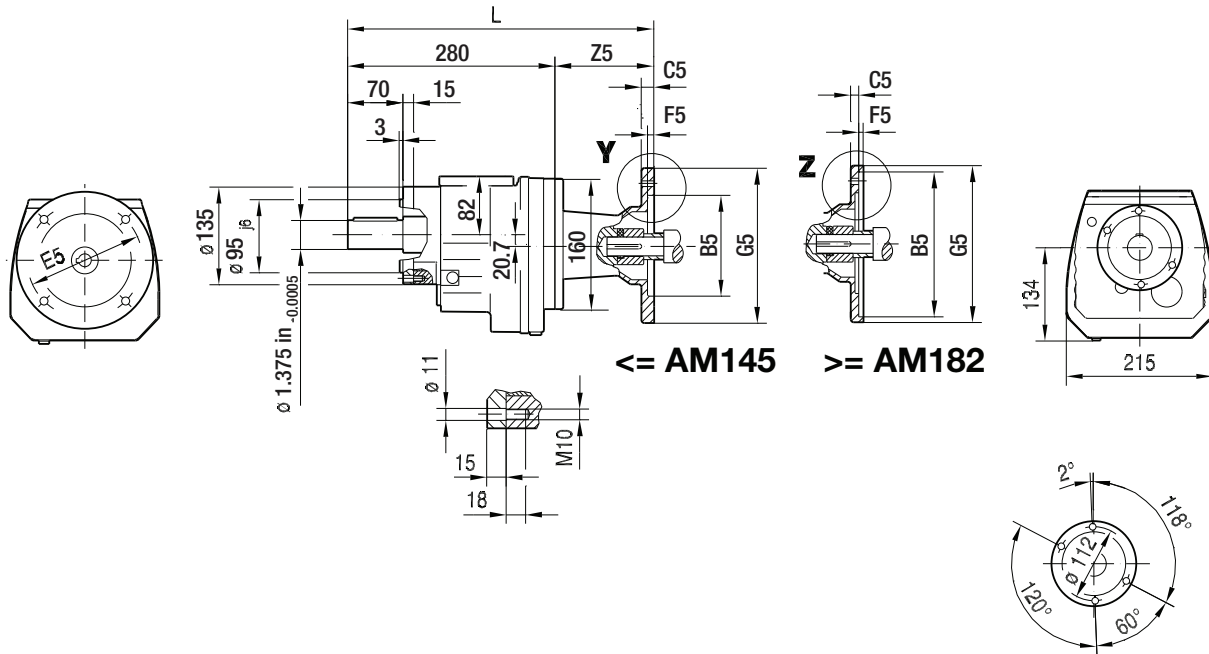

(→ 132)	B	B5	C5	E5	F5	G5	L	L1	L5	S5	T1	U	U1	Z5
AM56	1.23 in	4.50 in	11	5.875 in	4.5	170	367	1.88 in	-0.18 in	10.5	0.71 in	0.625 in	0.188 in	87
AM143	1.68 in	4.50 in	12	5.875 in	4.5	170	391	2.25 in	0.13 in	10.5	0.98 in	0.875 in	0.188 in	110.5
AM145	1.68 in	4.50 in	12	5.875 in	4.5	170	391	2.25 in	0.13 in	10.5	0.98 in	0.875 in	0.188 in	110.5
AM182	2.10 in	8.50 in	10	7.25 in	5	228	428	2.75 in	0.13 in	15	1.24 in	1.125 in	0.250 in	147.5
AM184	2.10 in	8.50 in	10	7.25 in	5	228	428	2.75 in	0.13 in	15	1.24 in	1.125 in	0.250 in	147.5
AM213/215	2.76 in	8.50 in	11	7.25 in	5	228	481	3.38 in	0.25 in	15	1.52 in	1.375 in	0.312 in	200.5

Note: Dimensions in mm unless otherwise noted. For all available output shaft diameters, see page 274. For dimensions of compound gear units (ex: RZ67R37) see page 269.

01 036 00 11

R77..

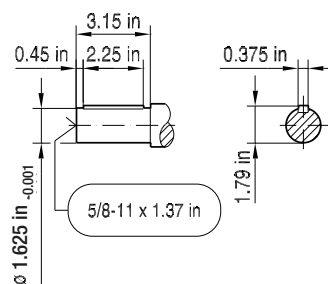
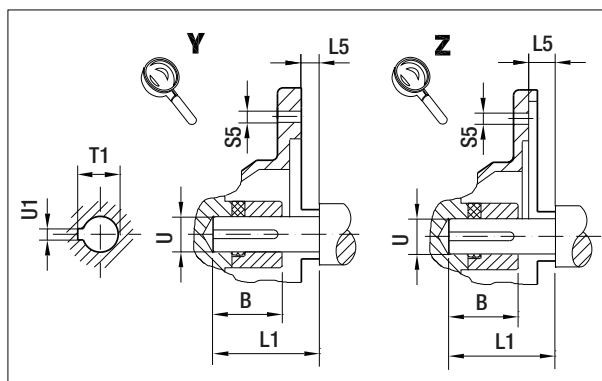
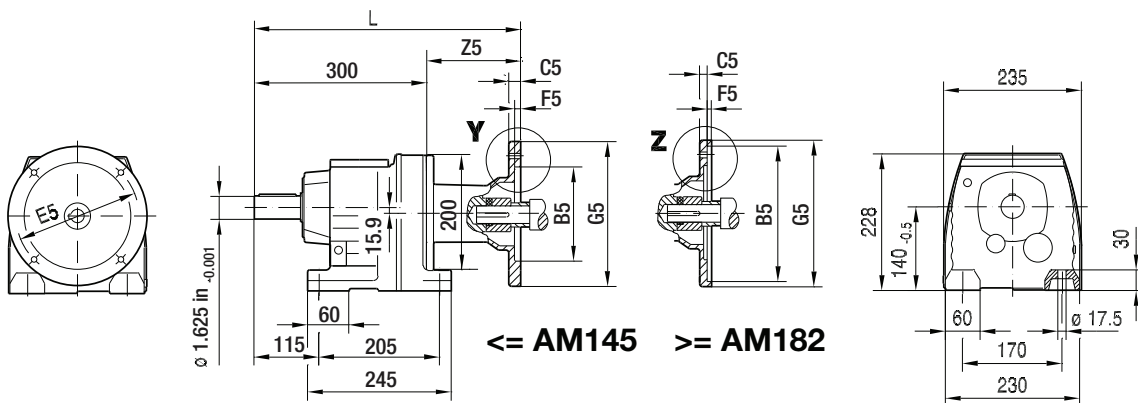

R77F..

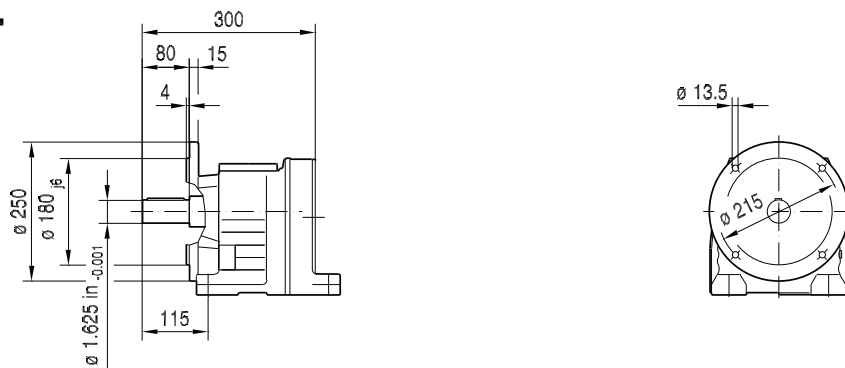

(→ 132)	B	B5	C5	E5	F5	G5	L	L1	L5	S5	T1	U	U1	Z5
AM56	1.23 in	4.50 in	11	5.875 in	4.5	170	381	1.88 in	-0.18 in	10.5	0.71 in	0.625 in	0.188 in	81
AM143	1.68 in	4.50 in	12	5.875 in	4.5	170	404	2.25 in	0.13 in	10.5	0.98 in	0.875 in	0.188 in	103.5
AM145	1.68 in	4.50 in	12	5.875 in	4.5	170	404	2.25 in	0.13 in	10.5	0.98 in	0.875 in	0.188 in	103.5
AM182	2.10 in	8.50 in	10	7.25 in	5	228	440	2.75 in	0.13 in	15	1.24 in	1.125 in	0.250 in	139.5
AM184	2.10 in	8.50 in	10	7.25 in	5	228	440	2.75 in	0.13 in	15	1.24 in	1.125 in	0.250 in	139.5
AM213/215	2.76 in	8.50 in	11	7.25 in	5	228	489	3.38 in	0.25 in	15	1.52 in	1.375 in	0.312 in	188.5

Note: Dimensions in mm unless otherwise noted. For all available output shaft diameters, see page 274. For dimensions of compound gear units (ex: R77R37) see page 269.

RF77..

01 037 00 11

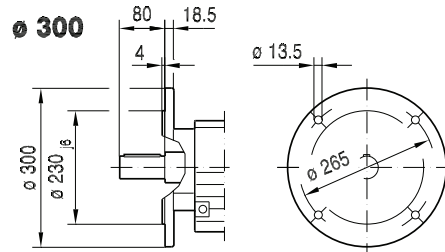
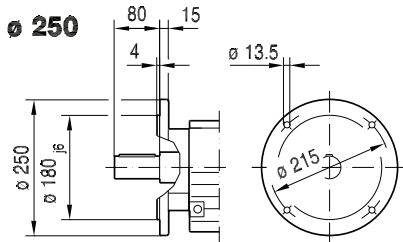
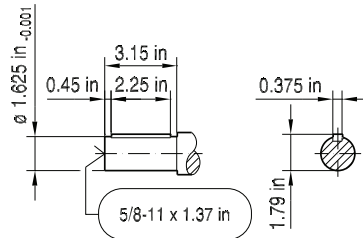
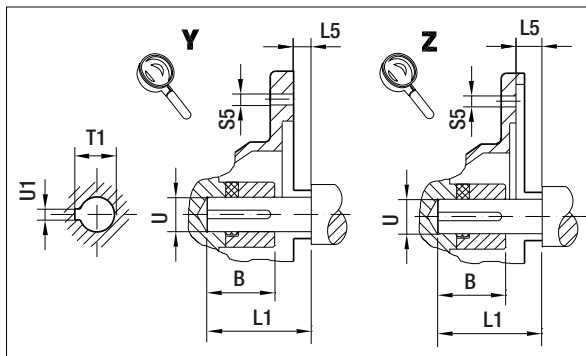
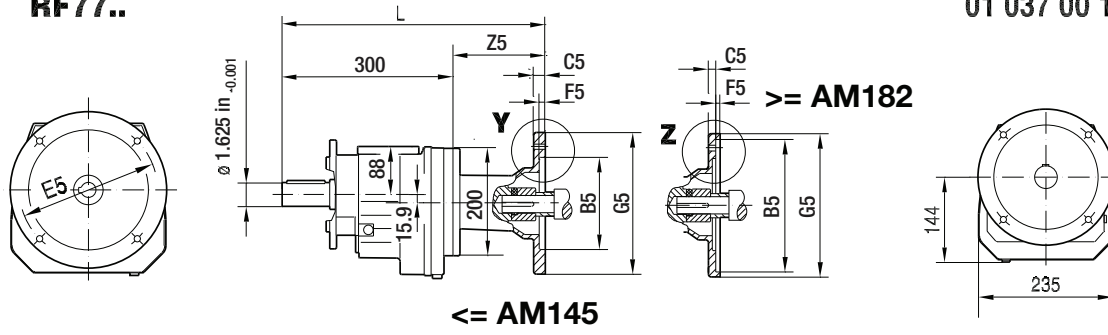

RM77..

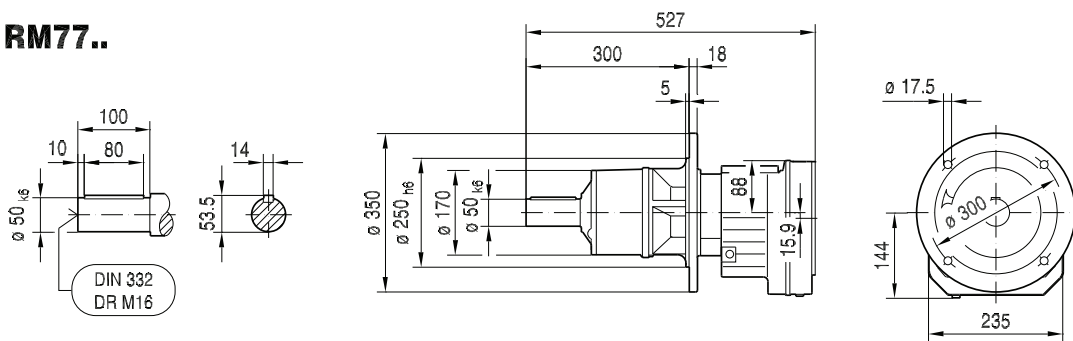

(→ 132)	B	B5	C5	E5	F5	G5	L	L1	L5	S5	T1	U	U1	Z5
AM56	1.23 in	4.50 in	11	5.875 in	4.5	170	381	1.88 in	-0.18 in	10.5	0.71 in	0.625 in	0.188 in	81
AM143	1.68 in	4.50 in	12	5.875 in	4.5	170	404	2.25 in	0.13 in	10.5	0.98 in	0.875 in	0.188 in	103.5
AM145	1.68 in	4.50 in	12	5.875 in	4.5	170	404	2.25 in	0.13 in	10.5	0.98 in	0.875 in	0.188 in	103.5
AM182	2.10 in	8.50 in	10	7.25 in	5	228	440	2.75 in	0.13 in	15	1.24 in	1.125 in	0.250 in	139.5
AM184	2.10 in	8.50 in	10	7.25 in	5	228	440	2.75 in	0.13 in	15	1.24 in	1.125 in	0.250 in	139.5
AM213/215	2.76 in	8.50 in	11	7.25 in	5	228	489	3.38 in	0.25 in	15	1.52 in	1.375 in	0.312 in	188.5

Note: Dimensions in mm unless otherwise noted. For all available output shaft diameters, see page 274. For dimensions of compound gear units (ex: RF77R37) see page 269.

01 038 00 11

RZ77..

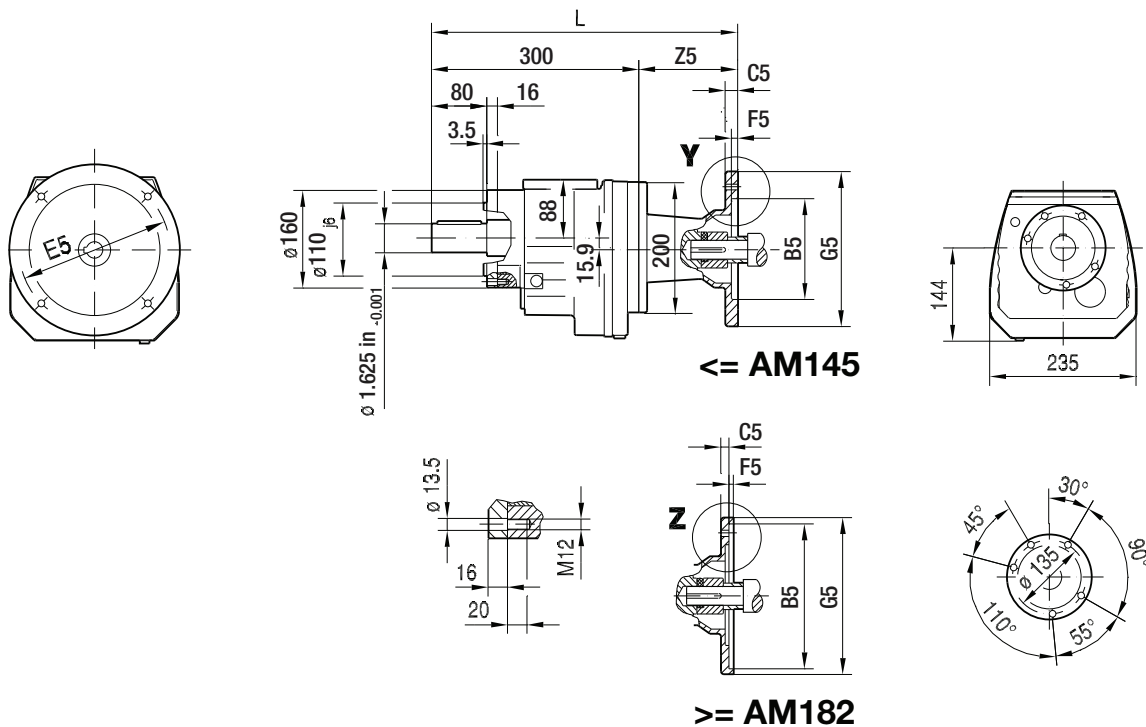

← AM145

→ AM182

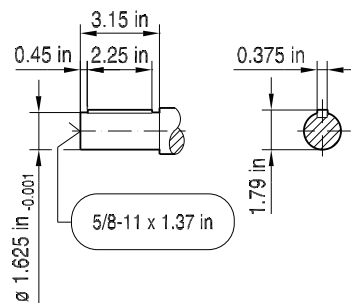
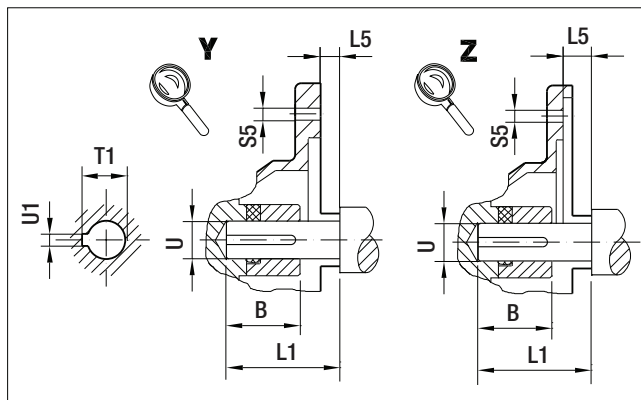

(→ 132)	B	B5	C5	E5	F5	G5	L	L1	L5	S5	T1	U	U1	Z5
AM56	1.23 in	4.50 in	11	5.875 in	4.5	170	381	1.88 in	-0.18 in	10.5	0.71 in	0.625 in	0.188 in	81
AM143	1.68 in	4.50 in	12	5.875 in	4.5	170	404	2.25 in	0.13 in	10.5	0.98 in	0.875 in	0.188 in	103.5
AM145	1.68 in	4.50 in	12	5.875 in	4.5	170	404	2.25 in	0.13 in	10.5	0.98 in	0.875 in	0.188 in	103.5
AM182	2.10 in	8.50 in	10	7.25 in	5	228	440	2.75 in	0.13 in	15	1.24 in	1.125 in	0.250 in	139.5
AM184	2.10 in	8.50 in	10	7.25 in	5	228	440	2.75 in	0.13 in	15	1.24 in	1.125 in	0.250 in	139.5
AM213/215	2.76 in	8.50 in	11	7.25 in	5	228	489	3.38 in	0.25 in	15	1.52 in	1.375 in	0.312 in	188.5

Note: Dimensions in mm unless otherwise noted. For all available output shaft diameters, see page 274. For dimensions of compound gear units (ex: RZ77R37) see page 269.

01 039 00 11

R87..

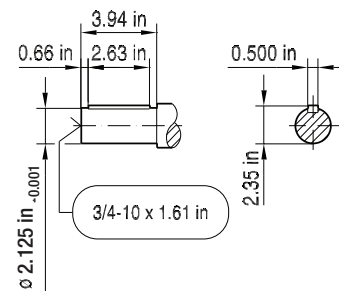
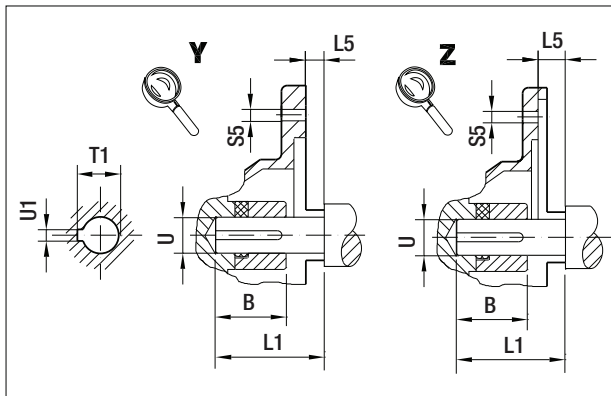
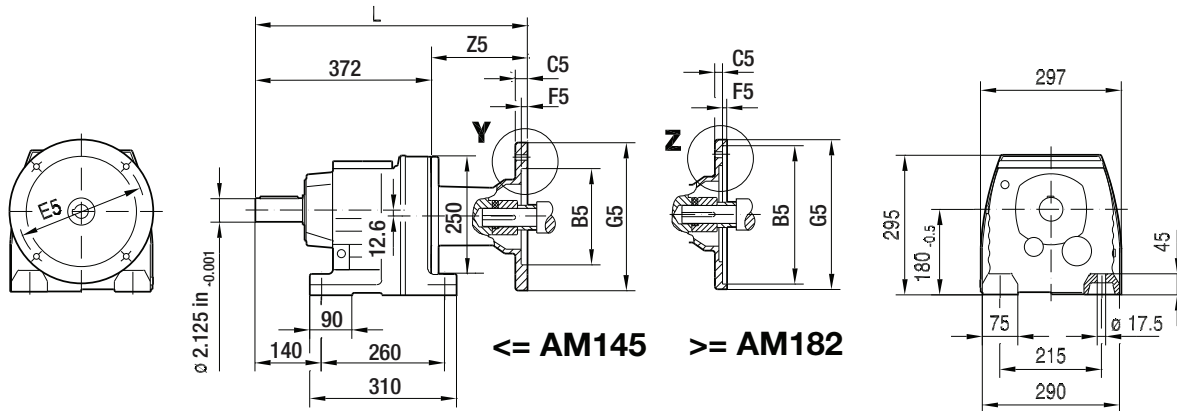

R87F..

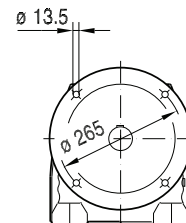
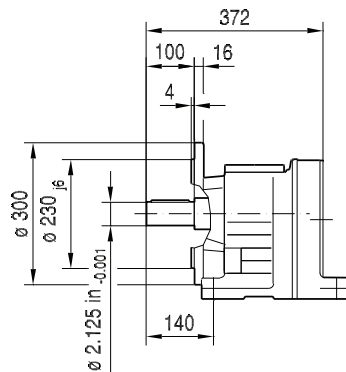

(→ 132)	B	B5	C5	E5	F5	G5	L	L1	L5	S5	T1	U	U1	Z5
AM143	1.68 in	4.50 in	12	5.875 in	4.5	170	471	2.25 in	0.13 in	10.5	0.98 in	0.875 in	0.188 in	98.5
AM145	1.68 in	4.50 in	12	5.875 in	4.5	170	471	2.25 in	0.13 in	10.5	0.98 in	0.875 in	0.188 in	98.5
AM182	2.10 in	8.50 in	10	7.25 in	5	228	507	2.75 in	0.13 in	15	1.24 in	1.125 in	0.250 in	134.5
AM184	2.10 in	8.50 in	10	7.25 in	5	228	507	2.75 in	0.13 in	15	1.24 in	1.125 in	0.250 in	134.5
AM213/215	2.76 in	8.50 in	11	7.25 in	5	228	556	3.38 in	0.25 in	15	1.52 in	1.375 in	0.312 in	183.5
AM254/256	3.65 in	8.50 in	14	7.25 in	5	228	606	4.00 in	0.25 in	15	1.80 in	1.625 in	0.375 in	234
AM284/286	4.00 in	10.50 in	15	9.00 in	5	286	613	4.62 in	0.25 in	15	2.10 in	1.875 in	0.500 in	241

Note: Dimensions in mm unless otherwise noted. For all available output shaft diameters, see page 274. For dimensions of compound gear units (ex: R87R57) see page 269.

RF87..

01 040 00 11

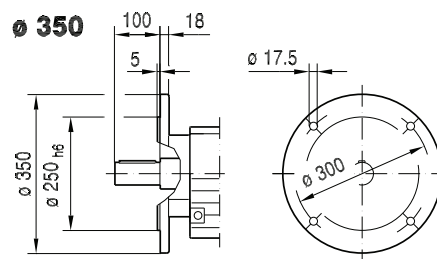
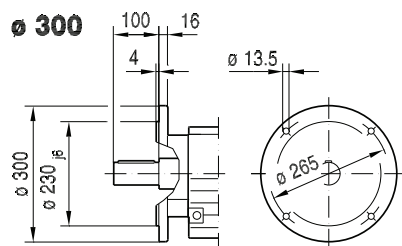
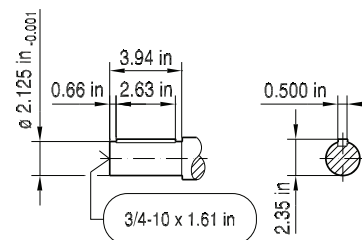
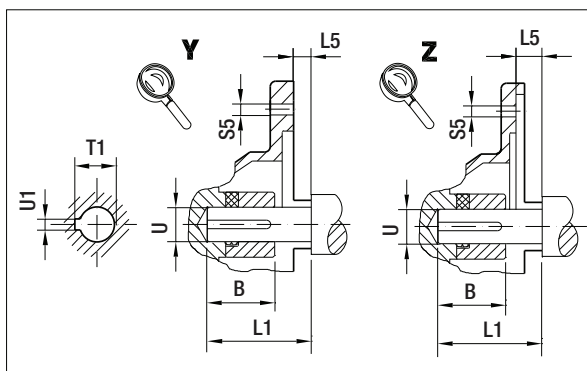
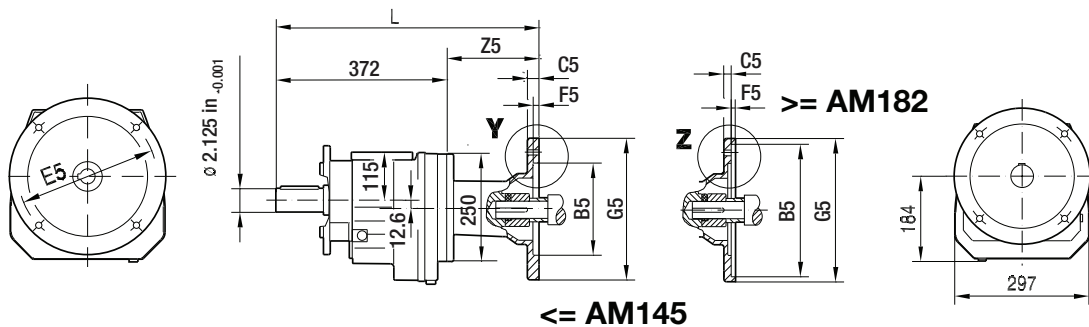

RM87..

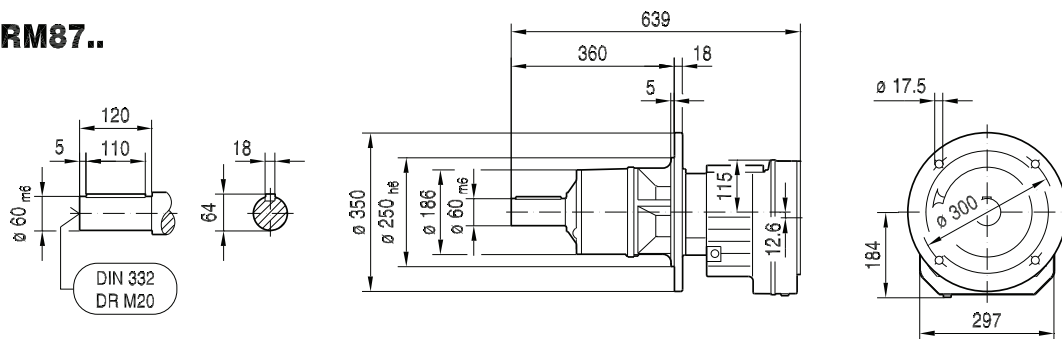

(→ 132)	B	B5	C5	E5	F5	G5	L	L1	L5	S5	T1	U	U1	Z5
AM143	1.68 in	4.50 in	12	5.875 in	4.5	170	471	2.25 in	0.13 in	10.5	0.98 in	0.875 in	0.188 in	98.5
AM145	1.68 in	4.50 in	12	5.875 in	4.5	170	471	2.25 in	0.13 in	10.5	0.98 in	0.875 in	0.188 in	98.5
AM182	2.10 in	8.50 in	10	7.25 in	5	228	507	2.75 in	0.13 in	15	1.24 in	1.125 in	0.250 in	134.5
AM184	2.10 in	8.50 in	10	7.25 in	5	228	507	2.75 in	0.13 in	15	1.24 in	1.125 in	0.250 in	134.5
AM213/215	2.76 in	8.50 in	11	7.25 in	5	228	556	3.38 in	0.25 in	15	1.52 in	1.375 in	0.312 in	183.5
AM254/256	3.65 in	8.50 in	14	7.25 in	5	228	606	4.00 in	0.25 in	15	1.80 in	1.625 in	0.375 in	234
AM284/286	4.00 in	10.50 in	15	9.00 in	5	286	613	4.62 in	0.25 in	15	2.10 in	1.875 in	0.500 in	241

Note: Dimensions in mm unless otherwise noted. For all available output shaft diameters, see page 274. For dimensions of compound gear units (ex: RF87R57) see page 269.

RZ87..

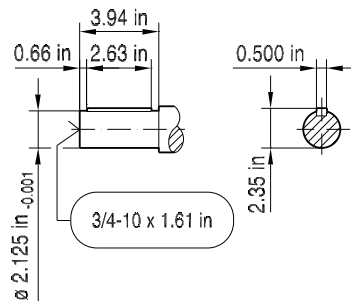
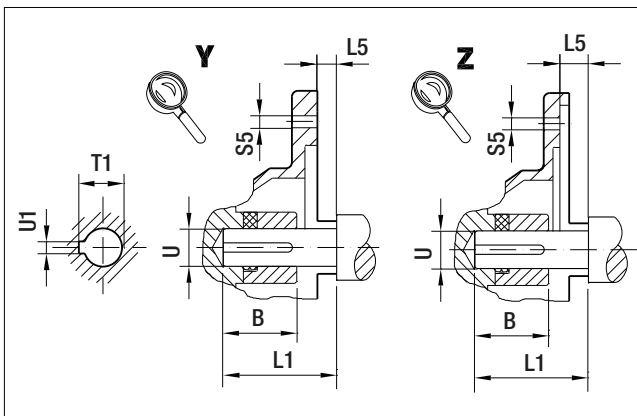
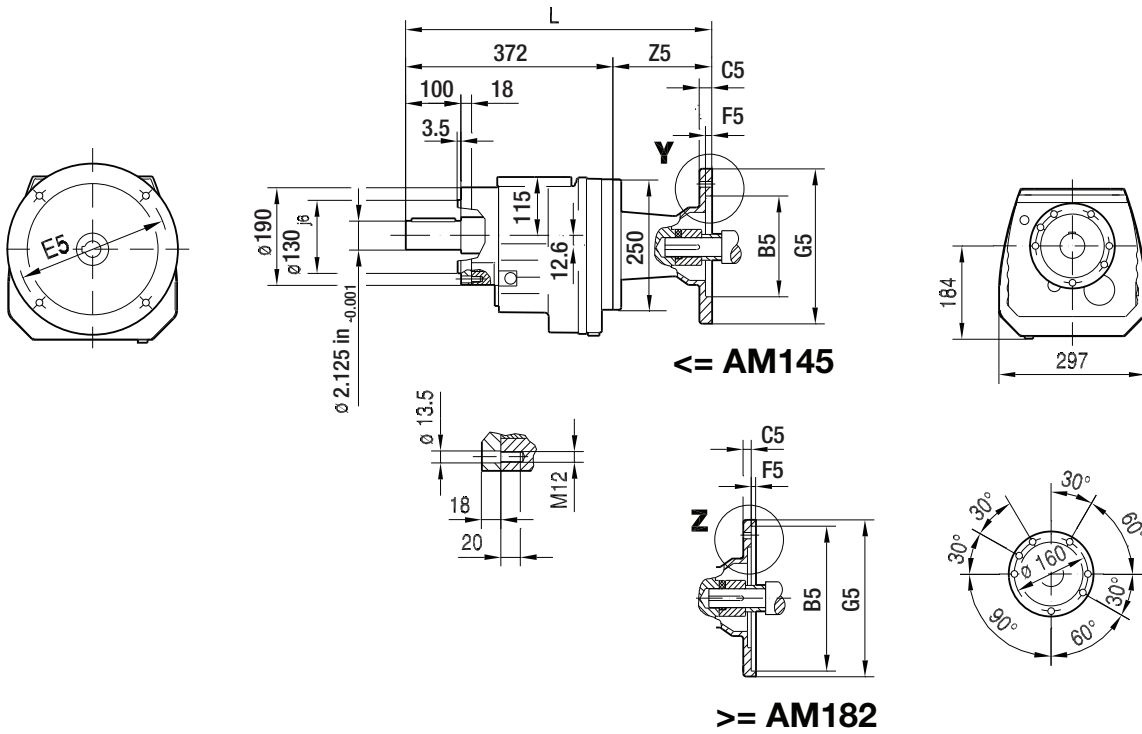

(→ 132)	B	B5	C5	E5	F5	G5	L	L1	L5	S5	T1	U	U1	Z5
AM143	1.68 in	4.50 in	12	5.875 in	4.5	170	471	2.25 in	0.13 in	10.5	0.98 in	0.875 in	0.188 in	98.5
AM145	1.68 in	4.50 in	12	5.875 in	4.5	170	471	2.25 in	0.13 in	10.5	0.98 in	0.875 in	0.188 in	98.5
AM182	2.10 in	8.50 in	10	7.25 in	5	228	507	2.75 in	0.13 in	15	1.24 in	1.125 in	0.250 in	134.5
AM184	2.10 in	8.50 in	10	7.25 in	5	228	507	2.75 in	0.13 in	15	1.24 in	1.125 in	0.250 in	134.5
AM213/215	2.76 in	8.50 in	11	7.25 in	5	228	556	3.38 in	0.25 in	15	1.52 in	1.375 in	0.312 in	183.5
AM254/256	3.65 in	8.50 in	14	7.25 in	5	228	606	4.00 in	0.25 in	15	1.80 in	1.625 in	0.375 in	234
AM284/286	4.00 in	10.50 in	15	9.00 in	5	286	613	4.62 in	0.25 in	15	2.10 in	1.875 in	0.500 in	241

Note: Dimensions in mm unless otherwise noted. For all available output shaft diameters, see page 274. For dimensions of compound gear units (ex: RZ87R57) see page 269.

01 042 00 11

R97..

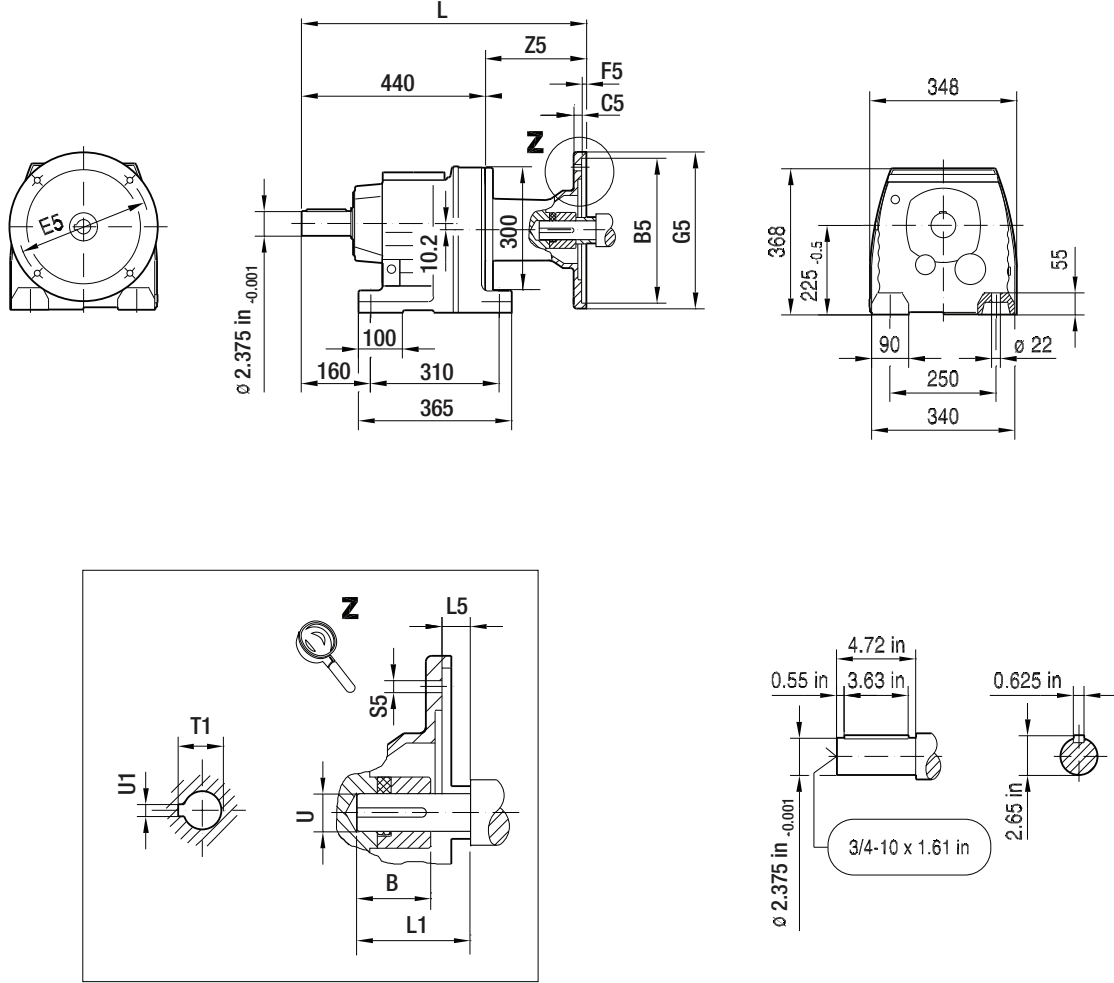

8

(→ 132)	B	B5	C5	E5	F5	G5	L	L1	L5	S5	T1	U	U1	Z5
AM182	2.10 in	8.50 in	10	7.25 in	5	228	570	2.75 in	0.13 in	15	1.24 in	1.125 in	0.250 in	129.5
AM184	2.10 in	8.50 in	10	7.25 in	5	228	570	2.75 in	0.13 in	15	1.24 in	1.125 in	0.250 in	129.5
AM213/215	2.76 in	8.50 in	11	7.25 in	5	228	619	3.38 in	0.25 in	15	1.52 in	1.375 in	0.312 in	178.5
AM254/256	3.65 in	8.50 in	12	7.25 in	5	228	669	4.00 in	0.25 in	15	1.80 in	1.625 in	0.375 in	229
AM284/286	4.00 in	10.50 in	15	9.00 in	5	286	676	4.62 in	0.25 in	15	2.10 in	1.875 in	0.500 in	236
AM324/326	3.88 in	12.50 in	17	11.0 in	5	356	736	5.25 in	0.25 in	17.5	2.36 in	2.125 in	0.500 in	296
AM364/365	4.51 in	12.50 in	17	11.0 in	5	356	736	5.88 in	0.25 in	17.5	2.66 in	2.375 in	0.625 in	296

Note: Dimensions in mm unless otherwise noted. For all available output shaft diameters, see page 274. For dimensions of compound gear units (ex: R97R57) see page 269.

01 043 00 11

RF97..

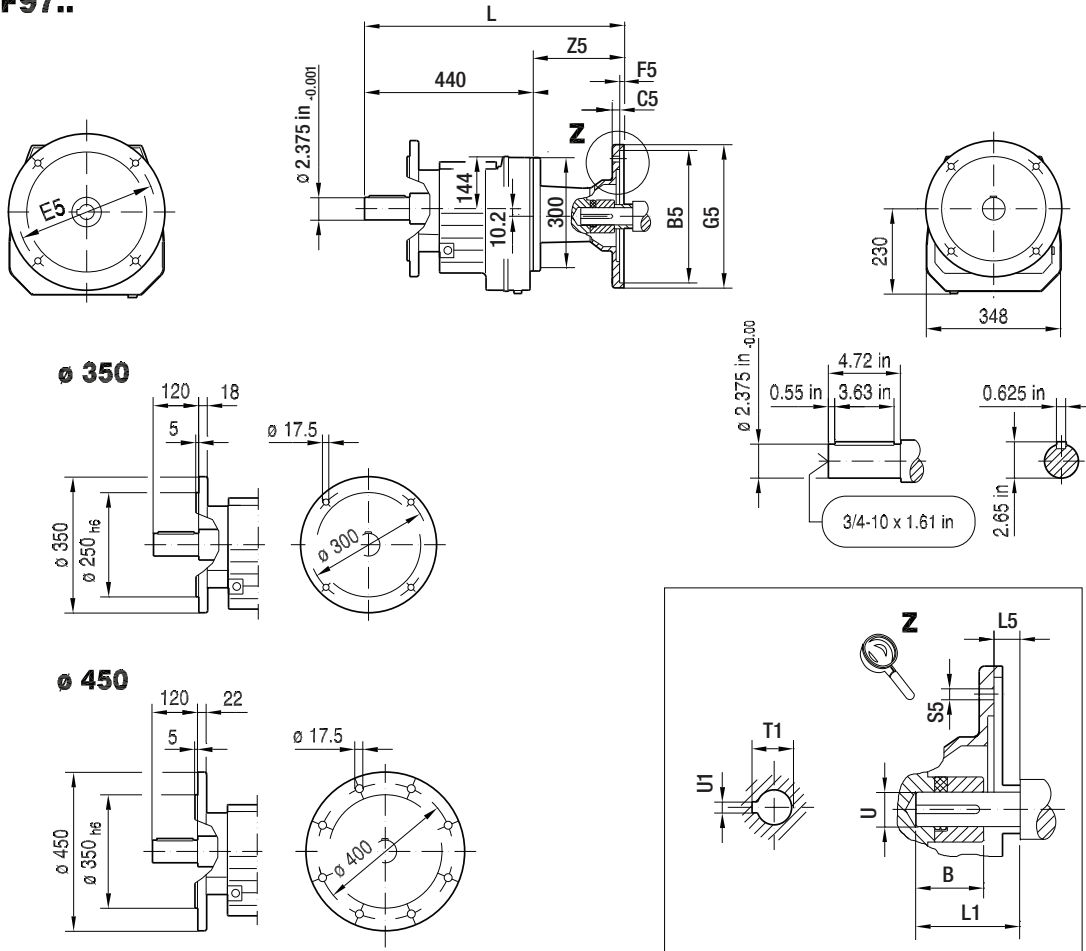

RM97..

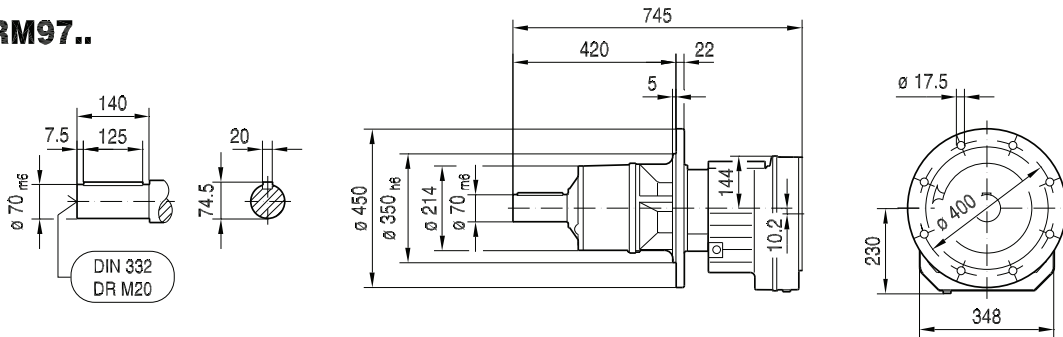

(→ 132)	B	B5	C5	E5	F5	G5	L	L1	L5	S5	T1	U	U1	Z5
AM182	2.10 in	8.50 in	10	7.25 in	5	228	570	2.75 in	0.13 in	15	1.24 in	1.125 in	0.250 in	129.5
AM184	2.10 in	8.50 in	10	7.25 in	5	228	570	2.75 in	0.13 in	15	1.24 in	1.125 in	0.250 in	129.5
AM213/215	2.76 in	8.50 in	11	7.25 in	5	228	619	3.38 in	0.25 in	15	1.52 in	1.375 in	0.312 in	178.5
AM254/256	3.65 in	8.50 in	12	7.25 in	5	228	669	4.00 in	0.25 in	15	1.80 in	1.625 in	0.375 in	229
AM284/286	4.00 in	10.50 in	15	9.00 in	5	286	676	4.62 in	0.25 in	15	2.10 in	1.875 in	0.500 in	236
AM324/326	3.88 in	12.50 in	17	11.0 in	5	356	736	5.25 in	0.25 in	17.5	2.36 in	2.125 in	0.500 in	296
AM364/365	4.51 in	12.50 in	17	11.0 in	5	356	736	5.88 in	0.25 in	17.5	2.66 in	2.375 in	0.625 in	296

Note: Dimensions in mm unless otherwise noted. For all available output shaft diameters, see page 274. For dimensions of compound gear units (ex: RF97R57) see page 269.

01 044 00 11

R107..

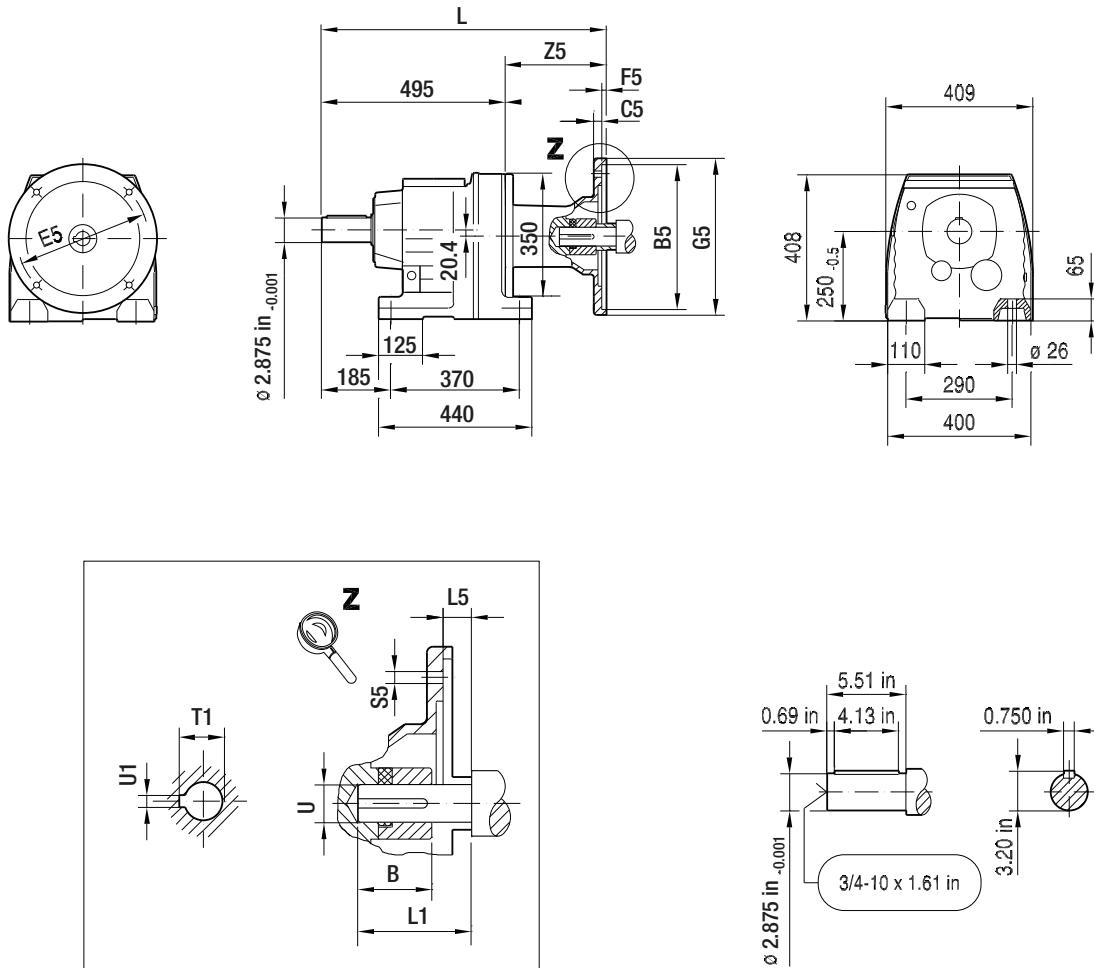

8

(→ 132)	B	B5	C5	E5	F5	G5	L	L1	L5	S5	T1	U	U1	Z5
AM182	2.10 in	8.50 in	10	7.25 in	5	228	619	2.75 in	0.13 in	15	1.24 in	1.125 in	0.250 in	123.5
AM184	2.10 in	8.50 in	10	7.25 in	5	228	619	2.75 in	0.13 in	15	1.24 in	1.125 in	0.250 in	123.5
AM213/215	2.76 in	8.50 in	11	7.25 in	5	228	668	3.38 in	0.25 in	15	1.52 in	1.375 in	0.312 in	172.5
AM254/256	3.65 in	8.50 in	12	7.25 in	5	228	718	4.00 in	0.25 in	15	1.80 in	1.625 in	0.375 in	223
AM284/286	4.00 in	10.50 in	15	9.00 in	5	286	725	4.62 in	0.25 in	15	2.10 in	1.875 in	0.500 in	230
AM324/326	3.88 in	12.50 in	17	11.0 in	5	356	785	5.25 in	0.25 in	17.5	2.36 in	2.125 in	0.500 in	290
AM364/365	4.51 in	12.50 in	17	11.0 in	5	356	785	5.88 in	0.25 in	17.5	2.66 in	2.375 in	0.625 in	290

Note: Dimensions in mm unless otherwise noted. For all available output shaft diameters, see page 274. For dimensions of compound gear units (ex: R107R77) see page 269.

01 045 00 11

RF107..

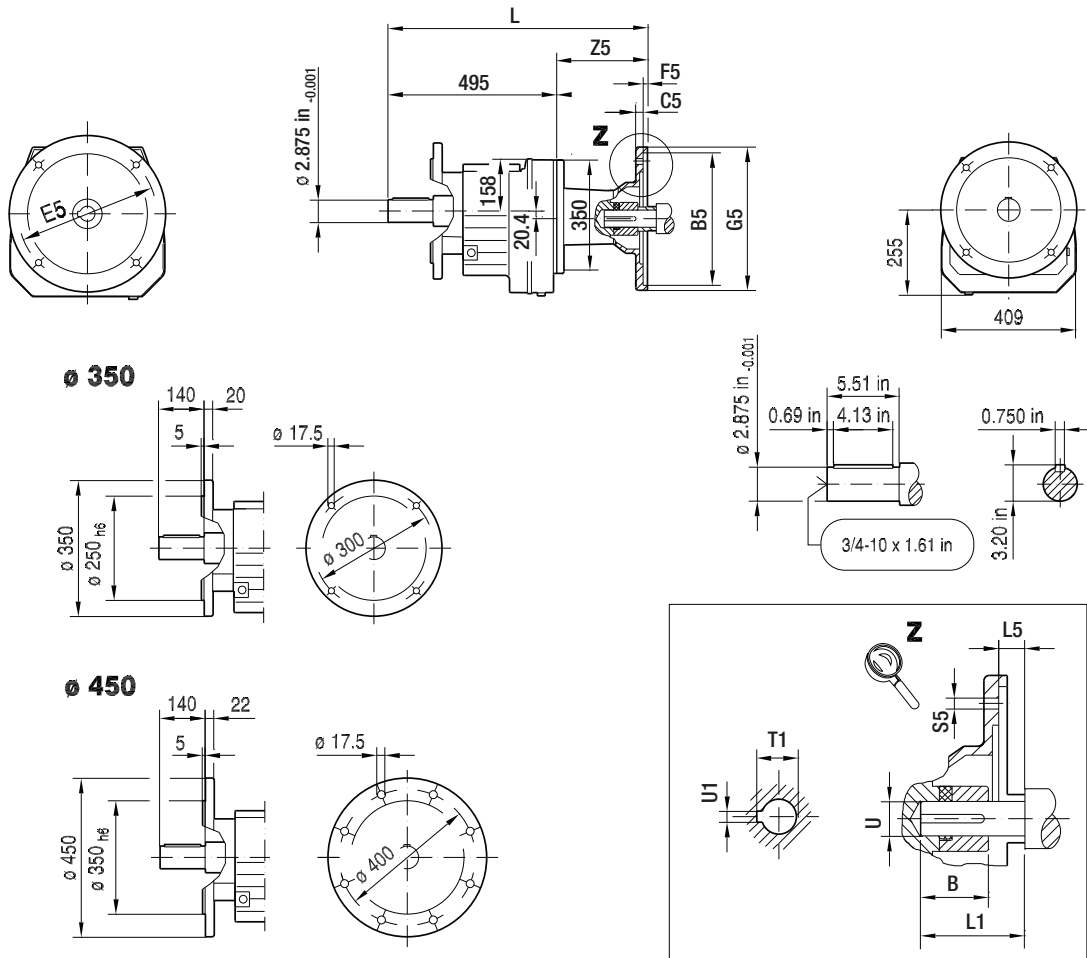

RM107..

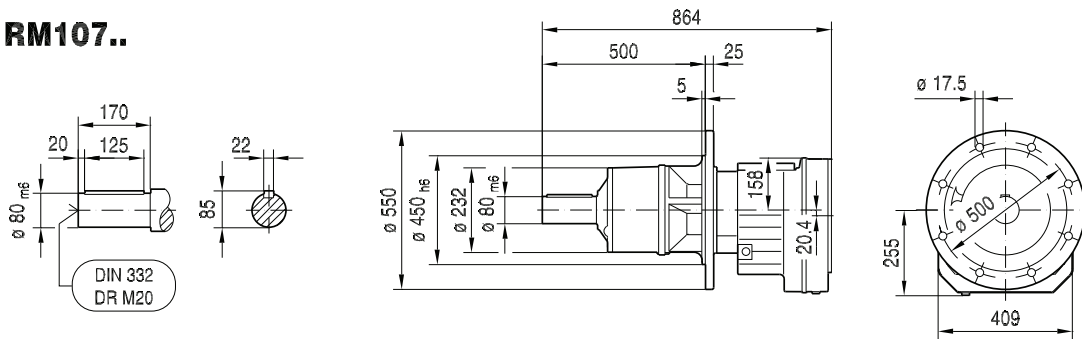

(→  132)	B	B5	C5	E5	F5	G5	L	L1	L5	S5	T1	U	U1	Z5
AM182	2.10 in	8.50 in	10	7.25 in	5	228	619	2.75 in	0.13 in	15	1.24 in	1.125 in	0.250 in	123.5
AM184	2.10 in	8.50 in	10	7.25 in	5	228	619	2.75 in	0.13 in	15	1.24 in	1.125 in	0.250 in	123.5
AM213/215	2.76 in	8.50 in	11	7.25 in	5	228	668	3.38 in	0.25 in	15	1.52 in	1.375 in	0.312 in	172.5
AM254/256	3.65 in	8.50 in	12	7.25 in	5	228	718	4.00 in	0.25 in	15	1.80 in	1.625 in	0.375 in	223
AM284/286	4.00 in	10.50 in	15	9.00 in	5	286	725	4.62 in	0.25 in	15	2.10 in	1.875 in	0.500 in	230
AM324/326	3.88 in	12.50 in	17	11.0 in	5	356	785	5.25 in	0.25 in	17.5	2.36 in	2.125 in	0.500 in	290
AM364/365	4.51 in	12.50 in	17	11.0 in	5	356	785	5.88 in	0.25 in	17.5	2.66 in	2.375 in	0.625 in	290

Note: Dimensions in mm unless otherwise noted. For all available output shaft diameters, see page 274. For dimensions of compound gear units (ex: RF107R77) see page 269.

01 046 00 11

R137..

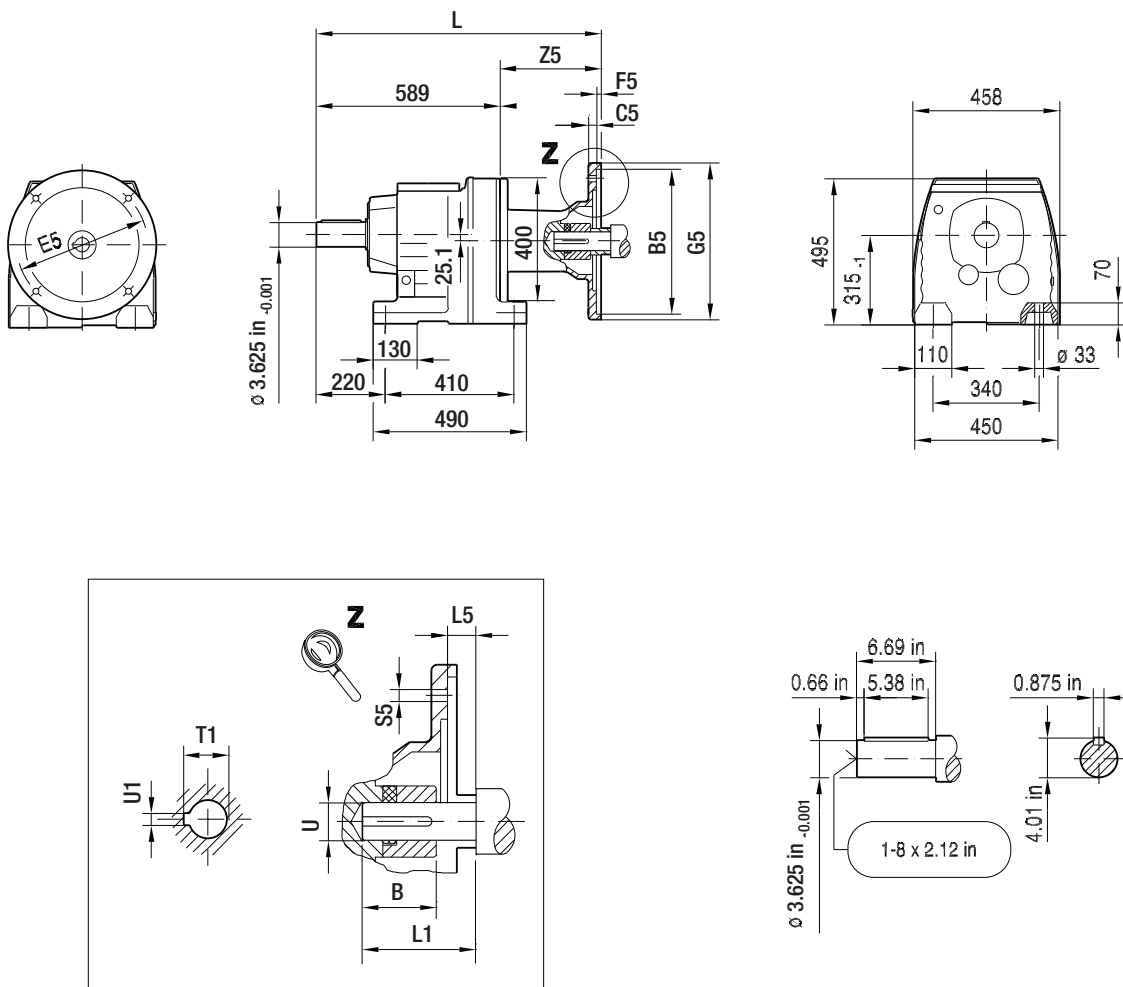

8

(→ 132)	B	B5	C5	E5	F5	G5	L	L1	L5	S5	T1	U	U1	Z5
AM213/215	2.76 in	8.50 in	11	7.25 in	5	228	755	3.38 in	0.25 in	15	1.52 in	1.375 in	0.312 in	165.5
AM254/256	3.65 in	8.50 in	12	7.25 in	5	228	805	4.00 in	0.25 in	15	1.80 in	1.625 in	0.375 in	216
AM284/286	4.00 in	10.50 in	15	9.00 in	5	286	812	4.62 in	0.25 in	15	2.10 in	1.875 in	0.500 in	223
AM324/326	3.88 in	12.50 in	17	11.0 in	5	356	872	5.25 in	0.25 in	17.5	2.36 in	2.125 in	0.500 in	283
AM364/365	4.51 in	12.50 in	17	11.0 in	5	356	872	5.88 in	0.25 in	17.5	2.66 in	2.375 in	0.625 in	283

Note: Dimensions in mm unless otherwise noted. For all available output shaft diameters, see page 274. For dimensions of compound gear units (ex: R137R77) see page 269.

01 047 00 11

RF137..

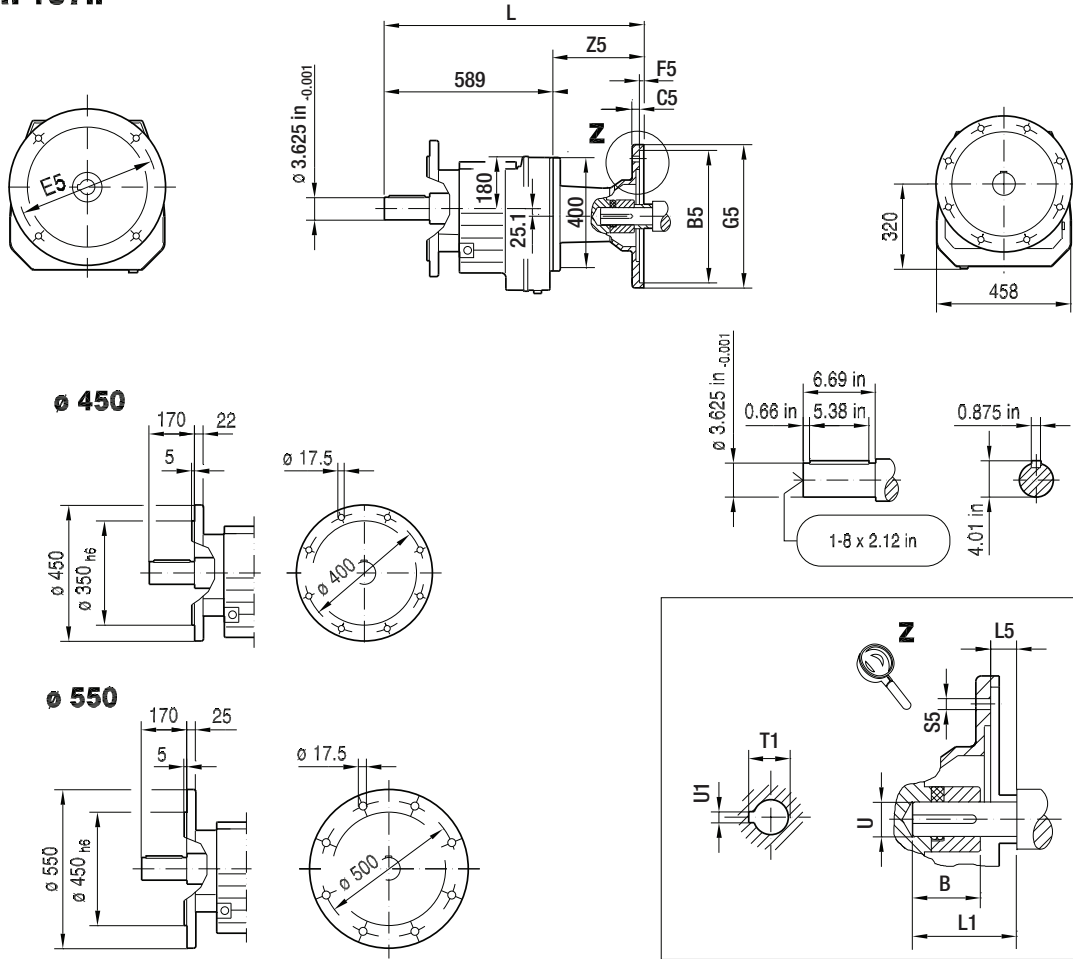

RM137..

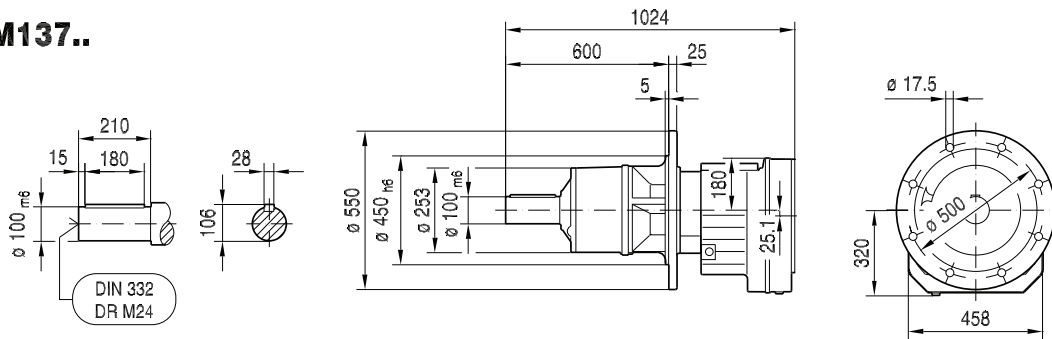

(→  132)	B	B5	C5	E5	F5	G5	L	L1	L5	S5	T1	U	U1	Z5
AM213/215	2.76 in	8.50 in	11	7.25 in	5	228	755	3.38 in	0.25 in	15	1.52 in	1.375 in	0.312 in	165.5
AM254/256	3.65 in	8.50 in	12	7.25 in	5	228	805	4.00 in	0.25 in	15	1.80 in	1.625 in	0.375 in	216
AM284/286	4.00 in	10.50 in	15	9.00 in	5	286	812	4.62 in	0.25 in	15	2.10 in	1.875 in	0.500 in	223
AM324/326	3.88 in	12.50 in	17	11.0 in	5	356	872	5.25 in	0.25 in	17.5	2.36 in	2.125 in	0.500 in	283
AM364/365	4.51 in	12.50 in	17	11.0 in	5	356	872	5.88 in	0.25 in	17.5	2.66 in	2.375 in	0.625 in	283

Note: Dimensions in mm unless otherwise noted. For all available output shaft diameters, see page 274. For dimensions of compound gear units (ex: RF137R77) see page 269.

01 048 00 11

R147..

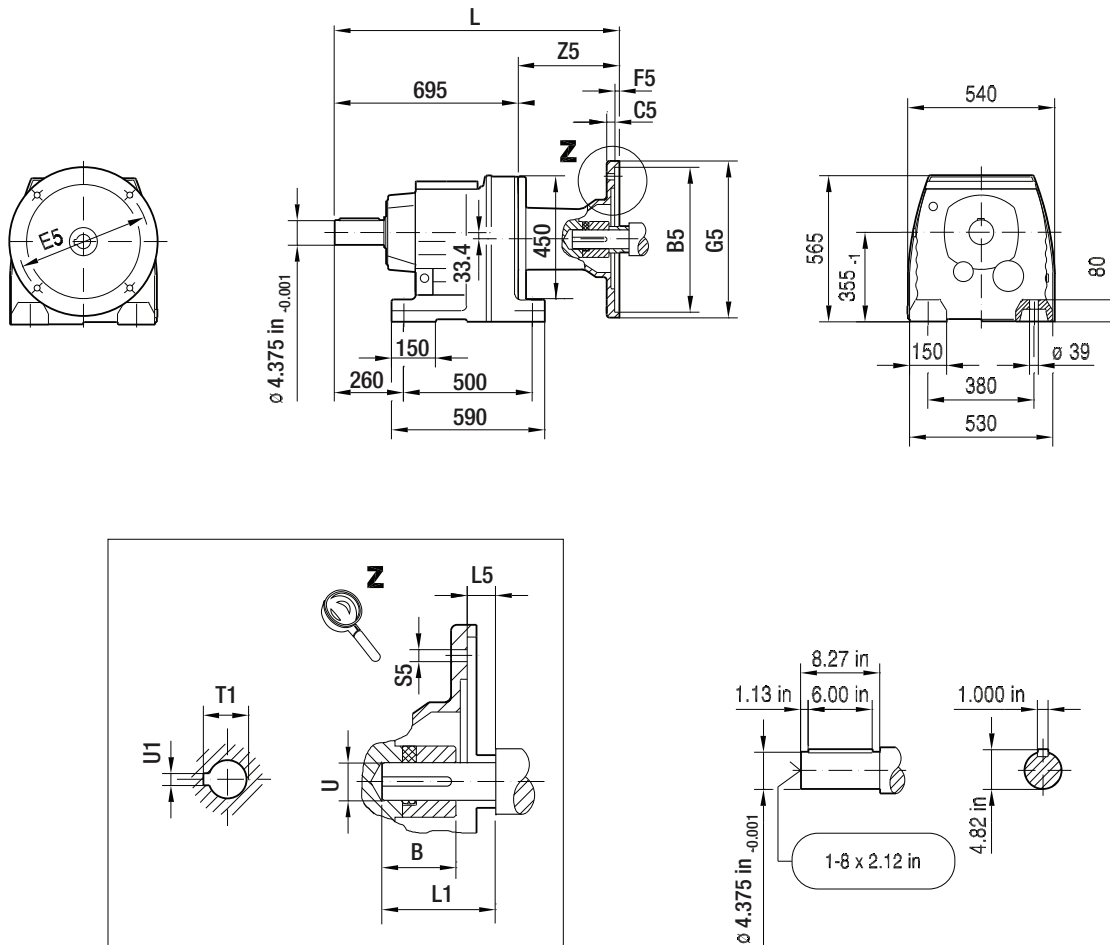

8

(→ 132)	B	B5	C5	E5	F5	G5	L	L1	L5	S5	T1	U	U1	Z5
AM254/256	3.65 in	8.50 in	12	7.25 in	5	228	903	4.00 in	0.25 in	15	1.80 in	1.625 in	0.375 in	208
AM284/286	4.00 in	10.50 in	15	9.00 in	5	286	910	4.62 in	0.25 in	15	2.10 in	1.875 in	0.500 in	215
AM324/326	3.88 in	12.50 in	17	11.0 in	5	356	970	5.25 in	0.25 in	17.5	2.36 in	2.125 in	0.500 in	275
AM364/365	4.51 in	12.50 in	17	11.0 in	5	356	970	5.88 in	0.25 in	17.5	2.66 in	2.375 in	0.625 in	275

Note: Dimensions in mm unless otherwise noted. For all available output shaft diameters, see page 274. For dimensions of compound gear units (ex: R147R77) see page 269.

01 049 00 11

RF147..

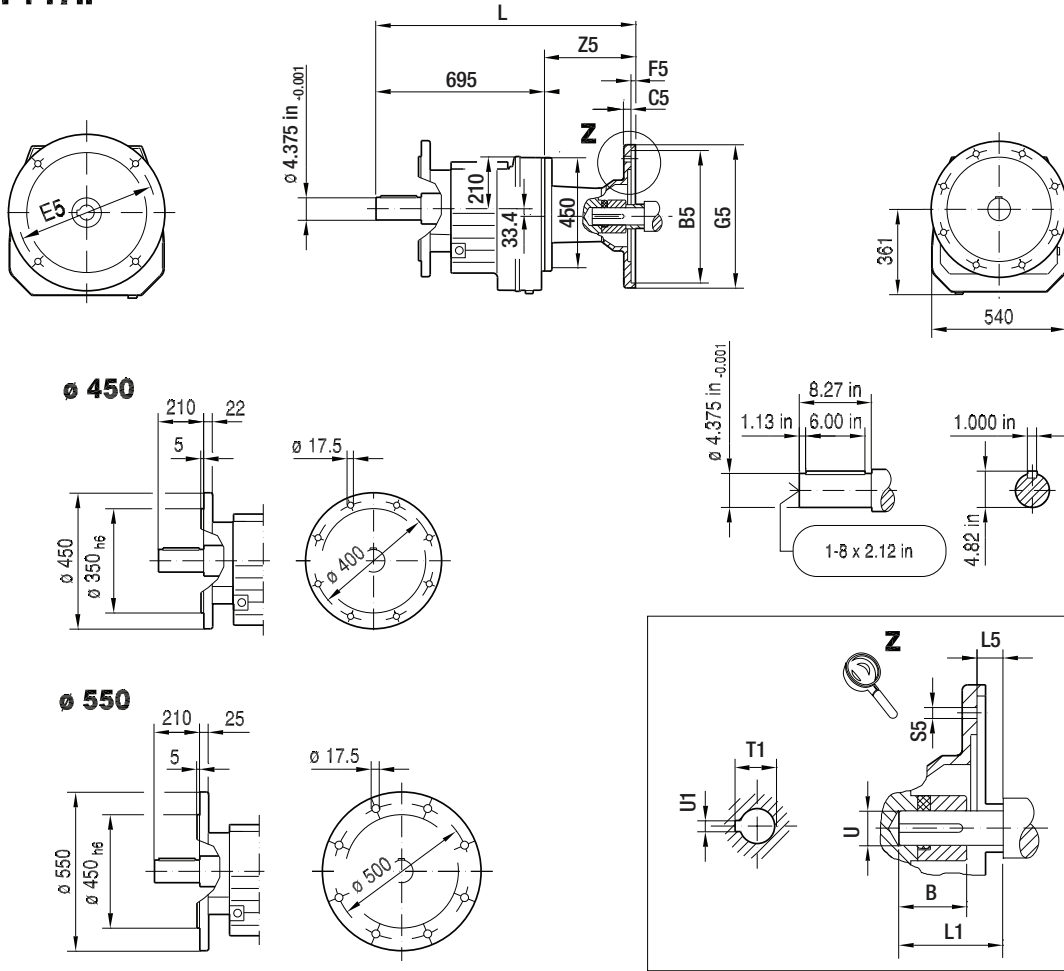

RM147..

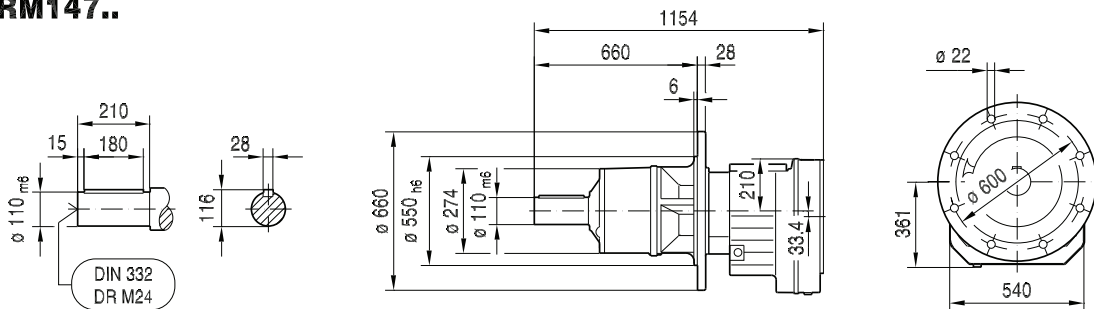

(→ 132)	B	B5	C5	E5	F5	G5	L	L1	L5	S5	T1	U	U1	Z5
AM254/256	3.65 in	8.50 in	12	7.25 in	5	228	903	4.00 in	0.25 in	15	1.80 in	1.625 in	0.375 in	208
AM284/286	4.00 in	10.50 in	15	9.00 in	5	286	910	4.62 in	0.25 in	15	2.10 in	1.875 in	0.500 in	215
AM324/326	3.88 in	12.50 in	17	11.0 in	5	356	970	5.25 in	0.25 in	17.5	2.36 in	2.125 in	0.500 in	275
AM364/365	4.51 in	12.50 in	17	11.0 in	5	356	970	5.88 in	0.25 in	17.5	2.66 in	2.375 in	0.625 in	275

Note: Dimensions in mm unless otherwise noted. For all available output shaft diameters, see page 274. For dimensions of compound gear units (ex: RF147R77) see page 269.

01 050 00 11

R167..

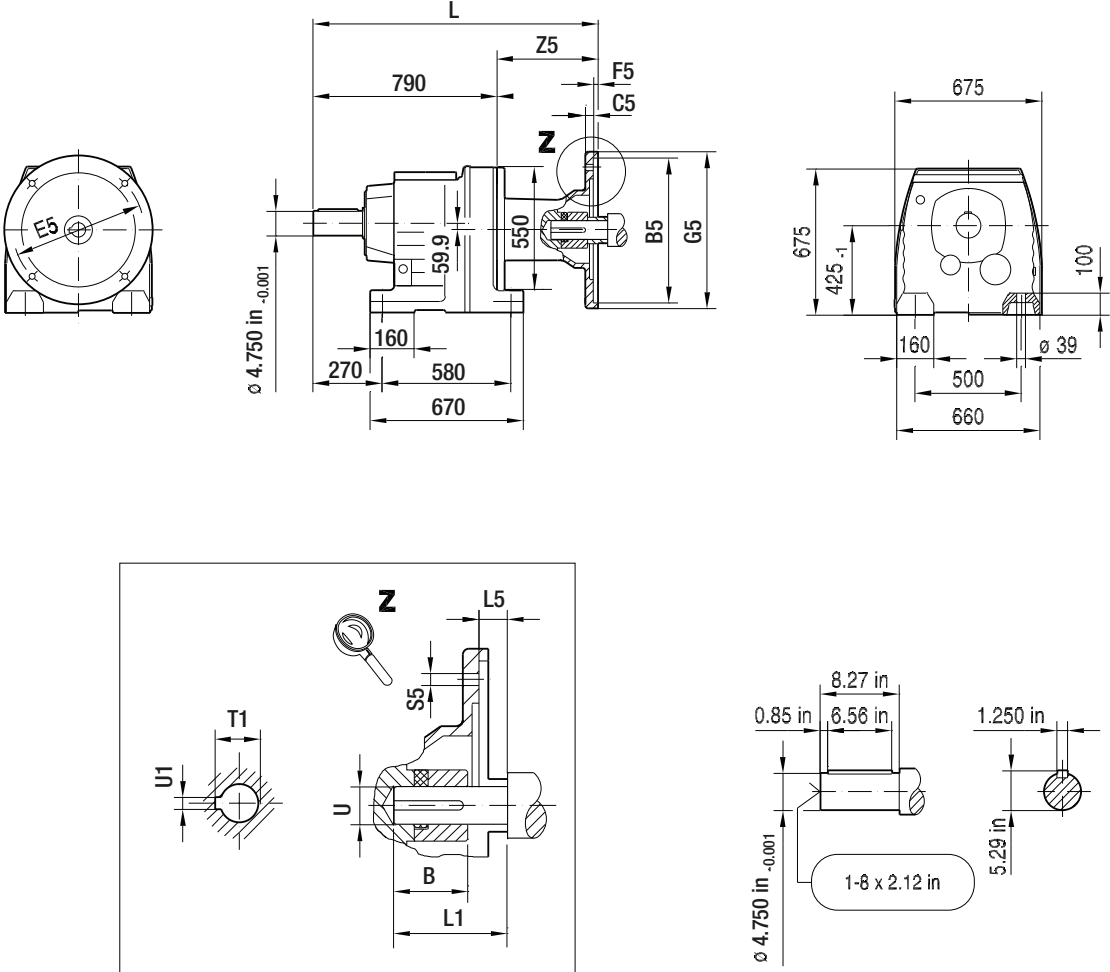

8

(→ 132)	B	B5	C5	E5	F5	G5	L	L1	L5	S5	T1	U	U1	Z5
AM254/256	3.65 in	8.50 in	12	7.25 in	5	228	990	4.00 in	0.25 in	15	1.80 in	1.625 in	0.375 in	200
AM284/286	4.00 in	10.50 in	15	9.00 in	5	286	997	4.62 in	0.25 in	15	2.10 in	1.875 in	0.500 in	207
AM324/326	3.88 in	12.50 in	17	11.0 in	5	356	1057	5.25 in	0.25 in	17.5	2.36 in	2.125 in	0.500 in	267
AM364/365	4.51 in	12.50 in	17	11.0 in	5	356	1057	5.88 in	0.25 in	17.5	2.66 in	2.375 in	0.625 in	267

Note: Dimensions in mm unless otherwise noted. For all available output shaft diameters, see page 274. For dimensions of compound gear units (ex: R167R97) see page 269.

01 051 00 11

RF167..

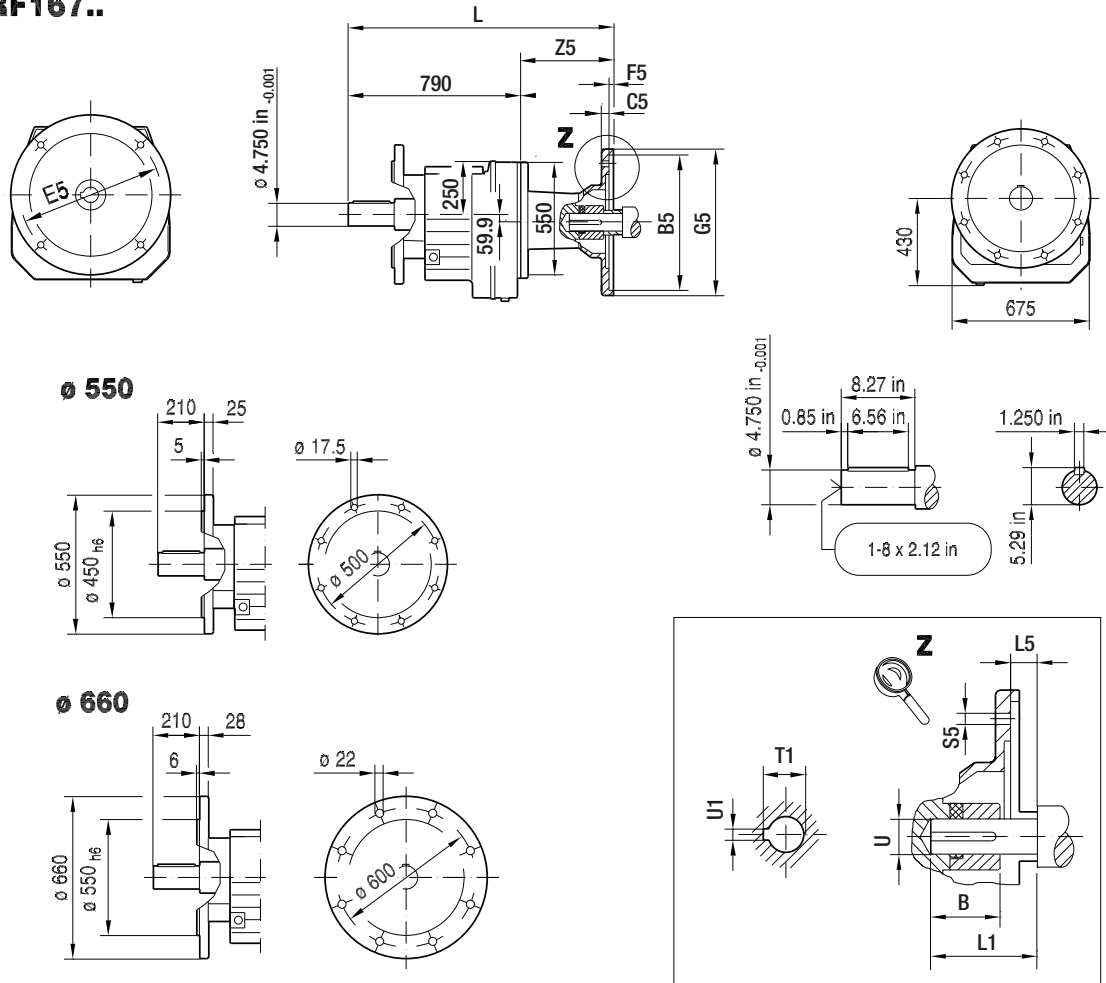

RM167..

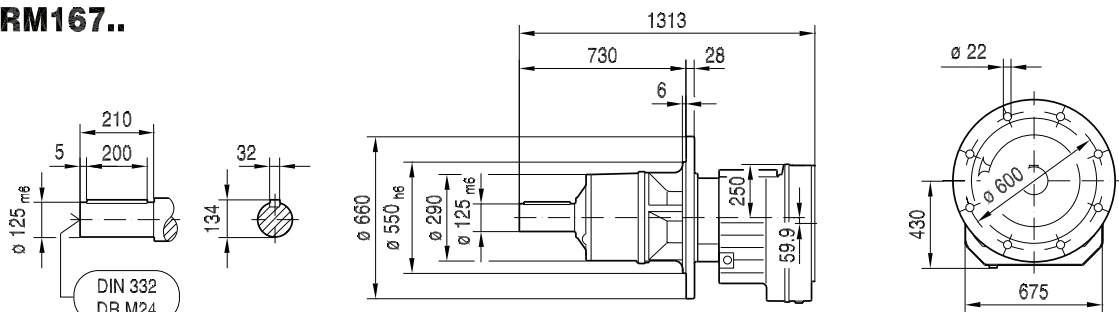

(→  132)	B	B5	C5	E5	F5	G5	L	L1	L5	S5	T1	U	U1	Z5
AM254/256	3.65 in	8.50 in	12	7.25 in	5	228	990	4.00 in	0.25 in	15	1.80 in	1.625 in	0.375 in	200
AM284/286	4.00 in	10.50 in	15	9.00 in	5	286	997	4.62 in	0.25 in	15	2.10 in	1.875 in	0.500 in	207
AM324/326	3.88 in	12.50 in	17	11.0 in	5	356	1057	5.25 in	0.25 in	17.5	2.36 in	2.125 in	0.500 in	267
AM364/365	4.51 in	12.50 in	17	11.0 in	5	356	1057	5.88 in	0.25 in	17.5	2.66 in	2.375 in	0.625 in	267

Note: Dimensions in mm unless otherwise noted. For all available output shaft diameters, see page 274. For dimensions of compound gear units (ex: RF167R97) see page 269.

8.4 R/RX..AM.. [IEC dimensions]

23 002 100

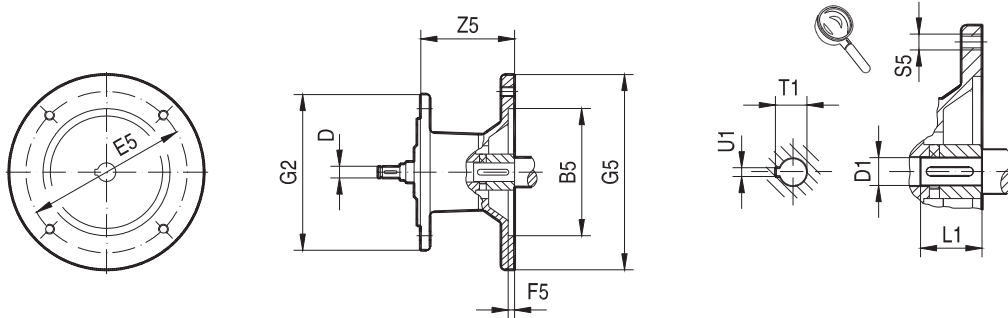

8

		Dimensions in mm											
		B5	D	E5	F5	G2	G5	S5	Z5	D1	L1	T1	U1
R..27 R..37	AM63	95	10	115	3.5	120	140	M8	72	11	23	12.8	4
	AM71 ¹⁾	110		130	4		160			14	30	16.3	5
	AM80 ¹⁾	130	12	165	4.5		200	M10	106	19	40	21.8	6
	AM90 ¹⁾		14							24	50	27.3	8
R..47 ²⁾ R..57 R..67	AM63	95	10	115	3.5	160	140	M8	66	11	23	12.8	4
	AM71	110		130	4		160			14	30	16.3	5
	AM80	130	12	165	4.5		200	M10	99	19	40	21.8	6
	AM90		14							24	50	27.3	8
	AM100 ¹⁾	180	16	215	5		250	M12	134	28	60	31.3	8
	AM112 ¹⁾		18							300	38	80	41.3
	AM132S/M ¹⁾	230	22	265	191		38	80	41.3	10			
R..77	AM63	95	10	115	3.5	200	140	M8	60	11	23	12.8	4
	AM71	110		130	4		160			14	30	16.3	5
	AM80	130	12	165	4.5		200	M10	92	19	40	21.8	6
	AM90		14							24	50	27.3	8
	AM100 ¹⁾	180	16	215	5		250	M12	126	28	60	31.3	8
	AM112 ¹⁾		18							300	38	80	41.3
	AM132S/M ¹⁾	230	22	265	179		38	80	41.3	10			
	AM132ML ¹⁾		28	300	38		80	41.3	10				
R..87	AM80	130	12	165	4.5	250	200	M10	87	19	40	21.8	6
	AM90		14							24	50	27.3	8
	AM100	180	16	215	5		250	M12	121	28	60	31.3	8
	AM112		18							300	38	80	41.3
	AM132S/M	230	22	265	174		38	80	41.3	10			
	AM132ML		28	300	38		80	41.3	10				
	AM160 ¹⁾	250	28	300	6		350	M16	232	42	110	45.3	12
AM180 ¹⁾	32		48			51.8				14			

1) Check dimension (G5)/2 as adapter may protrude past the bottom of the feet on a foot-mounted gear unit.

2) Not with AM112

Fig.1

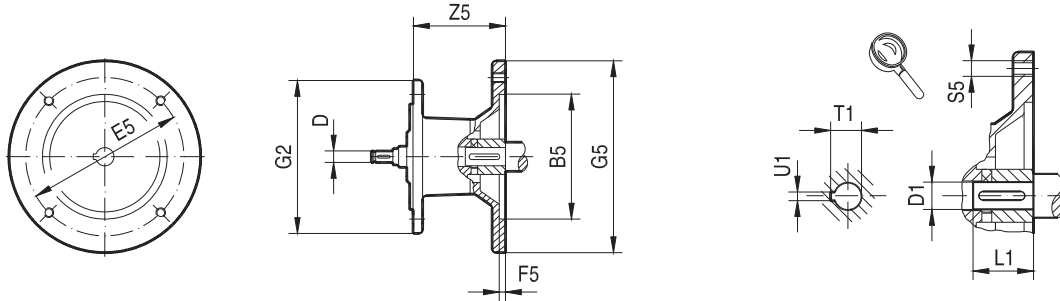

Fig.2

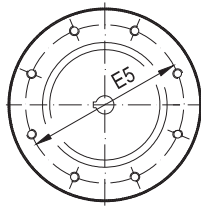

		Fig.	Dimensions in mm												
			B5	D	E5	F5	G2	G5	S5	Z5	D1	L1	T1	U1	
R..97	AM100	1	180	16	215	5	300	250	M12	116	28	60	31.3	8	
	AM112			18											
	AM132S/M		230	22	265										
	AM132ML			28											
	AM160		250	28	300			6	350	M16	227	42	110	45.3	12
	AM180			32								48		51.8	14
	AM200		300	38	350			7	400	268	55	59.3	16		
R..107	AM100	1	180	16	215	5	350	250	M12	110	28	60	31.3	8	
	AM112			18											
	AM132S/M		230	22	265										
	AM132ML			28											
	AM160		250	28	300			6	350	M16	221	42	110	45.3	12
	AM180			32								48		51.8	14
	AM200		300	38	350			7	400	262	55	59.3	16		
	AM225	2				350	38							400	450
R..137	AM132S/M	1	230	22	265	5	400	300	M12	156	38	80	41.3	10	
	AM132ML			28											
	AM160	250	28	300	6	350		M16	214	42	110	45.3	12		
	AM180		32							48		51.8	14		
	AM200	300	38	350	7	400		255	55	59.3	16				
	AM225											2	350	38	400

23 004 100

Fig.1

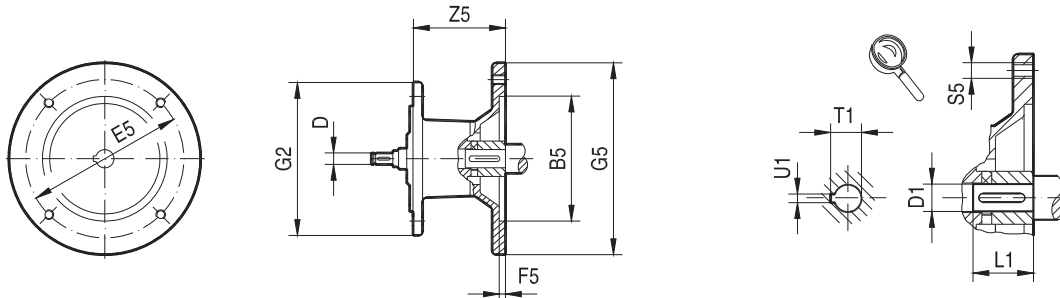

Fig.2

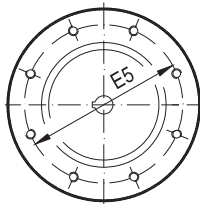
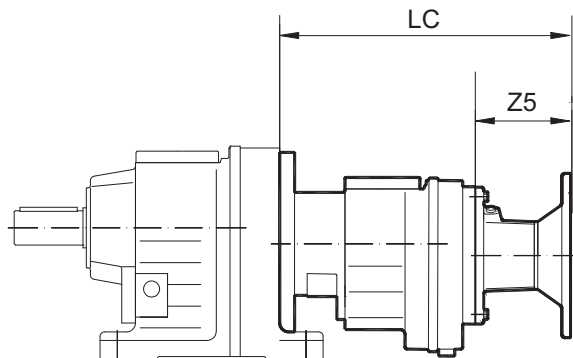

		Fig.	Dimensions in mm											
			B5	D	E5	F5	G2	G5	S5	Z5	D1	L1	T1	U1
R..147	AM132S/M	1	230	22	265	5	450	300	M12	148	38	80	41.3	10
	AM132ML			28							38			
	AM160		250	28	300	6		350	M16	206	42	110	45.3	12
	AM180			32							48		51.8	
	AM200	300	38	350	7	400		M16	247	55	140	59.3	16	
	AM225		38							60		64.4		
	AM250	450	48	500	7	550		M16	336	65	140	69.4	18	
	AM280									75		79.9		20
R..167	AM160	1	250	28	300	6	550	350	M16	198	42	110	45.3	12
	AM180			32							48			
	AM200		300	38	350	7		400	M16	239	55	140	59.3	16
	AM225			38							60		64.4	
	AM250	450	48	500	7	550		M16	328	65	140	69.4	18	
	AM280									75		79.9		20

8.5 R.. R.. AM.. [compound dimensions]



R_R_AM

Large Unit	Small Unit	Adapter	Z5	LC
R..47 R..57 R..67	R37	AM56	93.5	258.5
		AM143	117	282
		AM145	117	282
R..77	R37	AM56	93.5	250.5
		AM143	117	274
		AM145	117	274
R..87	R57	AM56	87	303
		AM143	110.5	326.5
		AM145	110.5	326.5
		AM182	147.5	363.5
		AM184	147.5	363.5
		AM213/215	200.5	416.5
R..97	R57	AM56	87	298
		AM143	110.5	321.5
		AM145	110.5	321.5
		AM182	147.5	358.5
		AM184	147.5	358.5
R..107	R77	AM56	81	328
		AM143	103.5	350.5
		AM145	103.5	350.5
		AM182	139.5	386.5
		AM184	139.5	386.5
		AM213/215	188.5	435.5
R..137	R77	AM56	81	321
		AM143	103.5	343.5
		AM145	103.5	343.5
		AM182	139.5	379.5
		AM184	139.5	379.5
		AM213/215	188.5	428.5

Large Unit	Small Unit	Adapter	Z5	LC
R..147	R77	AM56	81	313
		AM143	103.5	335.5
		AM145	103.5	335.5
		AM182	139.5	371.5
		AM184	139.5	371.5
	AM213/215	188.5	420.5	
	R87	AM143	98.5	378.5
		AM145	98.5	378.5
		AM182	134.5	414.5
		AM184	134.5	414.5
AM213/215		183.5	463.5	
R..167	R97	AM254/256	234	514
		AM284/286	241	521
		AM182	129.5	454.5
		AM184	129.5	454.5
		AM213/215	178.5	503.5
		AM254/256	229	554
	R107	AM284/286	236	561
		AM324/326	296	621
		AM364/365	296	621
		AM182	123.5	505.5
R..167	R107	AM184	123.5	505.5
		AM213/215	172.5	554.5
		AM254/256	223	605
		AM284/286	230	612
		AM324/326	290	672
AM364/365	290	672		

8.6 R/RX.. AD.. [dimensions]

8.6.1 Input shaft - Inch

R.. AD..

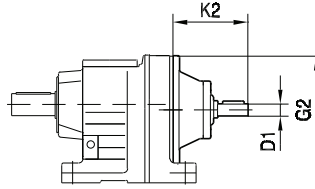
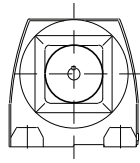

01 054 01 01US

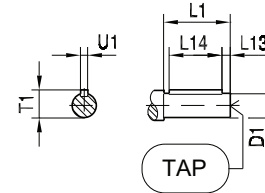

R.. AD../ZR

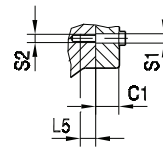
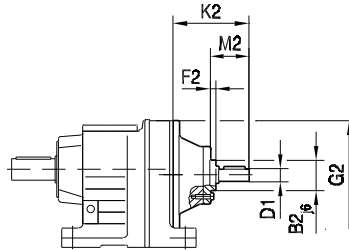
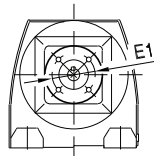

		B2	C1	D1	E1	F2	G2	K2	L1	L5	L13	L14	M2	S1	S2	T1	U1	TAP (inch)	
R.27 R/RX.37	AD1	-	-	0.625 in	-	-	120	102	40	-	4	32	-	-	-	0.70 in	0.1875 in	1/4-20 x0.63	
	AD2	55	13.5	0.750 in	80	8		130	40	12	4	32	50	9	M8	0.83 in			
R/RX.47 R/RX.57 R/RX.67	AD2	55	13.5	0.750 in	80	8	160	123	40	12	4	32	50	9	M8	0.83 in	0.1875 in	1/2-13 x1.12	
	AD3	70	15.5	0.875 in	105	8		159	50	16	5	40	60	11	M10	0.96 in			
R/RX.77	AD2	55	13.5	0.750 in	80	8	200	116	40	12	4	32	50	9	M8	0.83 in	0.1875 in	1/4-20 x0.63	
	AD3	70	15.5	0.875 in	105	8		151	50	16	5	40	60	11	M10	0.96 in			
	AD4	100	16	1.375 in	130	13		224	80	20	5	70	95.5	13.5	M12	1.51 in			0.3125 in
R/RX.87	AD2	55	13.5	0.750 in	80	8	250	111	40	12	4	32	50	9	M8	0.83 in	0.1875 in	1/4-20 x0.63	
	AD3	70	15.5	0.875 in	105	8		156	60	16	5	50	70	11	M10	0.96 in			
	AD4	100	16	1.375 in	130	13		219	80	20	5	70	95.5	13.5	M12	1.51 in			0.3125 in
	AD5	120	24	1.625 in	180	11		292	110	20	10	70	126	13.5	M12	1.79 in			0.375 in
R/RX.97	AD3	70	15.5	0.875 in	105	8	300	151	60	16	5	50	70	11	M10	0.96 in	0.1875 in	5/16-18 x0.87	
	AD4	100	16	1.375 in	130	13		214	80	20	5	70	95.5	13.5	M12	1.51 in			0.3125 in
	AD5	120	24	1.625 in	180	11		287	110	20	10	70	126	13.5	M12	1.79 in			0.375 in
	AD6	130	22.5	1.875 in	200	11		327	110	26	10	80	130.5	17.5	M16	2.09 in			0.50 in
R/RX.107	AD3	70	15.5	0.875 in	105	8	350	145	60	16	5	50	70	11	M10	0.96 in	0.1875 in	5/16-18 x0.87	
	AD4	100	16	1.375 in	130	13		208	80	20	5	70	95.5	13.5	M12	1.51 in			0.3125 in
	AD5	120	24	1.625 in	180	11		281	110	20	10	70	126	13.5	M12	1.79 in			0.375 in
	AD6	130	22.5	1.875 in	200	11		321	110	26	10	80	130.5	17.5	M16	2.09 in			0.50 in
R.137	AD4	100	16	1.375 in	130	13	400	201	80	20	5	70	95.5	13.5	M12	1.51 in	0.3125 in	1/2-13 x1.12	
	AD5	120	24	1.625 in	180	11		274	110	20	10	70	126	13.5	M12	1.79 in			0.375 in
	AD6	130	22.5	1.875 in	200	11		314	110	26	10	80	130.5	17.5	M16	2.09 in			0.50 in
	AD7	125	19	2.125 in	190	13		308	110	30	10	90	133	22	M20	2.35 in			3/4-10 x1.61
R.147	AD4	100	16	1.375 in	130	13	450	193	80	20	5	70	95.5	13.5	M12	1.51 in	0.3125 in	1/2-13 x1.12	
	AD5	120	24	1.625 in	180	11		266	110	20	10	70	126	13.5	M12	1.79 in			0.375 in
	AD6	130	22.5	1.875 in	200	11		306	110	26	10	80	130.5	17.5	M16	2.09 in			0.50 in
	AD7	125	19	2.125 in	190	13		300	110	30	10	90	133	22	M20	2.35 in			3/4-10 x1.61
R.167	AD8	120	22.5	2.750 in	210	5	550	383	140	19.5	15	110	155	13.5	M12	3.03 in	0.625 in	5/8-11 x1.38	
	AD5	120	24	1.625 in	180	11		258	110	20	10	70	126	13.5	M12	1.79 in	0.375 in		
	AD6	130	22.5	1.875 in	200	11		298	110	26	10	80	130.5	17.5	M16	2.09 in	0.50 in		
	AD7	125	19	2.125 in	190	13		292	110	30	10	90	133	22	M20	2.35 in	3/4-10 x1.61		
	AD8	120	22.5	2.750 in	210	5		374	140	19.5	15	110	155	13.5	M12	3.03 in	0.625 in		

8.6.2 Input shaft - Metric

R.. AD..

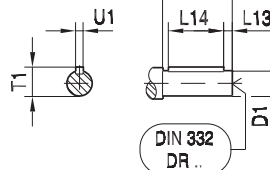
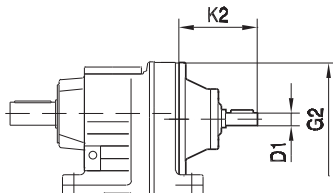
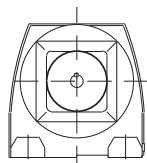

01 054 01 01

R.. AD../ZR

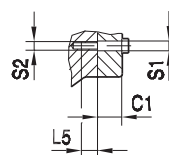
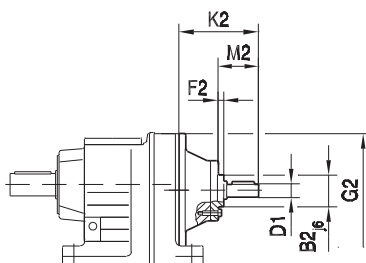
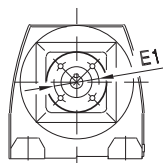

		B2	C1	E1	F2	G2	K2	L5	M2	S1	S2	D1	L1	L13	L14	T1	U1
R.27 R/RX.37	AD1	-	-	-	-	120	102	-	-	-	-	16	40	4	32	18	5
	AD2, AD2/ZR	55	13.5	80	8		130	12	50	9	M8	19	40	4	32	21.5	6
R/RX.47 R/RX.57 R/RX.67	AD2, AD2/ZR	55	13.5	80	8	160	123	12	50	9	M8	19	40	4	32	21.5	6
	AD3, AD3/ZR	70	15.5	105	8		159	16	60	11	M10	24	50	5	40	27	8
R/RX.77	AD2, AD2/ZR	55	13.5	80	8	200	116	12	50	9	M8	19	40	4	32	21.5	6
	AD3, AD3/ZR	70	15.5	105	8		151	16	60	11	M10	24	50	5	40	27	8
	AD4, AD4/ZR	100	16	130	13		224	20	95.5	13.5	M12	38	80	5	70	41	10
R/RX.87	AD2, AD2/ZR	55	13.5	80	8	250	111	12	50	9	M8	19	40	4	32	21.5	6
	AD3, AD3/ZR	70	15.5	105	8		156	16	70	11	M10	28	60	5	50	31	8
	AD4, AD4/ZR	100	16	130	13		219	20	95.5	13.5	M12	38	80	5	70	41	10
	AD5, AD5/ZR	120	24	180	11		292	20	126	13.5	M12	42	110	10	70	45	12
R/RX.97	AD3, AD3/ZR	70	15.5	105	8	300	151	16	70	11	M10	28	60	5	50	31	8
	AD4, AD4/ZR	100	16	130	13		214	20	95.5	13.5	M12	38	80	5	70	41	10
	AD5, AD5/ZR	120	24	180	11		287	20	126	13.5	M12	42	110	10	70	45	12
	AD6, AD6/ZR	130	22.5	200	11		327	26	130.5	17.5	M16	48	110	10	80	51.5	14
R/RX.107	AD3, AD3/ZR	70	15.5	105	8	350	145	16	70	11	M10	28	60	5	50	31	8
	AD4, AD4/ZR	100	16	130	13		208	20	95.5	13.5	M12	38	80	5	70	41	10
	AD5, AD5/ZR	120	24	180	11		281	20	126	13.5	M12	42	110	10	70	45	12
	AD6, AD6/ZR	130	22.5	200	11		321	26	130.5	17.5	M16	48	110	10	80	51.5	14
R.137	AD4, AD4/ZR	100	16	130	13	400	201	20	95.5	13.5	M12	38	80	5	70	41	10
	AD5, AD5/ZR	120	24	180	11		274	20	126	13.5	M12	42	110	10	70	45	12
	AD6, AD6/ZR	130	22.5	200	11		314	26	130.5	17.5	M16	48	110	10	80	51.5	14
	AD7, AD7/ZR	125	19	190	13		308	30	133	22	M20	55	110	10	90	59	16
R.147	AD4, AD4/ZR	100	16	130	13	450	193	20	95.5	13.5	M12	38	80	5	70	41	10
	AD5, AD5/ZR	120	24	180	11		266	20	126	13.5	M12	42	110	10	70	45	12
	AD6, AD6/ZR	130	22.5	200	11		306	26	130.5	17.5	M16	48	110	10	80	51.5	14
	AD7, AD7/ZR	125	19	190	13		300	30	133	22	M20	55	110	10	90	59	16
	AD8, AD8/ZR	120	22.5	210	5		383	19.5	155	13.5	M12	70	140	15	110	74.5	20
R.167	AD5, AD5/ZR	120	24	180	11	550	258	20	126	13.5	M12	42	110	10	70	45	12
	AD6, AD6/ZR	130	22.5	200	11		298	26	130.5	17.5	M16	48	110	10	80	51.5	14
	AD7, AD7/ZR	125	19	190	13		292	30	133	22	M20	55	110	10	90	59	16
	AD8, AD8/ZR	120	22.5	210	5		374	19.5	155	13.5	M12	70	140	15	110	74.5	20

8.7 R.. R.. AD.. [compound dimensions]

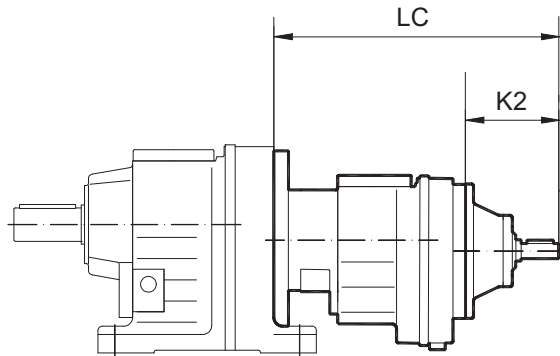

R_R_AD

8

Large Unit	Small Unit	Adapter	K2	LC
R..47 R..57 R..67	R37	AD1	102	267
		AD2	130	295
R..77	R37	AD1	102	259
		AD2	130	287
R..87	R57	AD2	123	339
		AD3	159	375
R..97	R57	AD2	123	334
		AD3	159	370
R..107	R77	AD2	116	363
		AD3	151	398
		AD4	224	471
R..137	R77	AD2	116	356
		AD3	151	391
		AD4	224	464
R..147	R77	AD2	116	348
		AD3	151	383
		AD4	224	456
	R87	AD2	111	391
		AD3	156	436
		AD4	219	499
R..167	R97	AD5	292	572
		AD3	151	476
		AD4	214	539
	R107	AD5	287	612
		AD6	327	652
		AD3	145	527
		AD4	208	590
		AD5	281	663
		AD6	321	703

8.8 R/RX.. AD/P [dimensions]

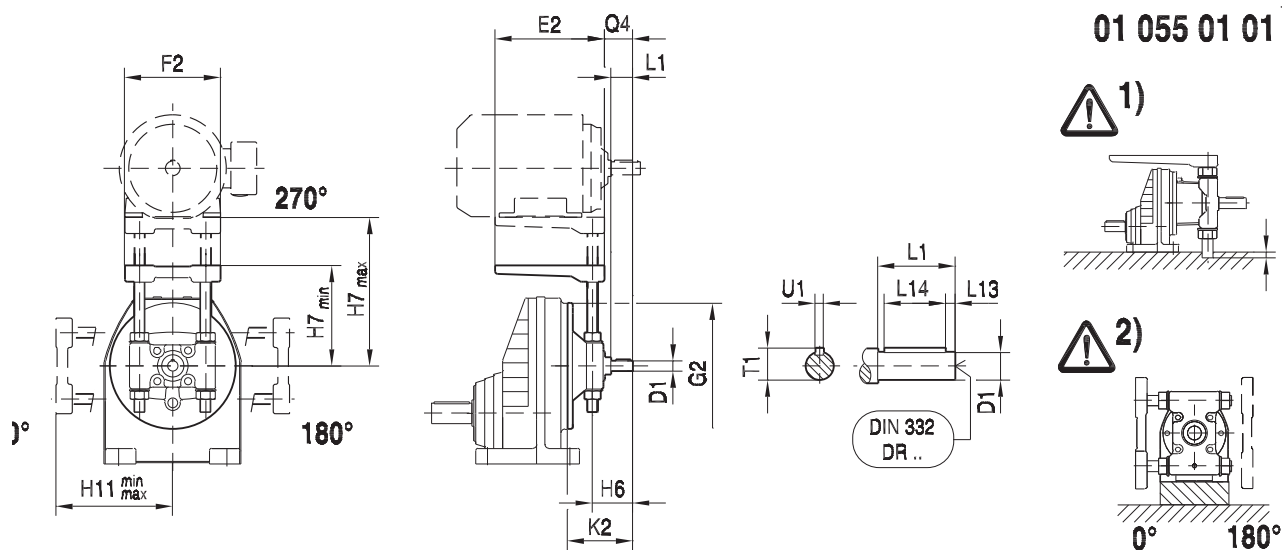

		E2	F2	G2	H6	H7 min	H7 max	H11 min	H11 max	K2	Q4	D1	L1	L13	L14	T1	U1	→131
RX..57	AD2/P	195	180	160	65	110	165	115	165	123	43	19	40	4	32	21.5	6	
	AD3/P	230	240		80	110	175	120	175	159	54	24	50	5	40	27	8	1), 2)
RX..67	AD2/P	195	180	160	65	110	165	125	165	123	43	19	40	4	32	21.5	6	
	AD3/P	230	240		80	110	175	130	175	159	54	24	50	5	40	27	8	1)
RX..77	AD2/P	195	180	200	65	130	165	140	200	116	43	19	40	4	32	21.5	6	
	AD3/P	230	240		80	135	175	145	175	151	54	24	50	5	40	27	8	
	AD4/P	345	291		118	145	210	160	210	224	83	38	80	5	70	41	10	1), 2)
RX..87	AD2/P	195	180	250	65	160	200	170	200	111	43	19	40	4	32	21.5	6	
	AD3/P	230	240		90	165	230	175	230	156	64	28	60	5	50	31	8	
	AD4/P	345	291		118	170	210	195	280	219	83	38	80	5	70	41	10	
	AD5/P	430	355		153	175	250	200	250	292	113	42	110	10	70	45	12	1), 2)
RX..97	AD3/P	230	240	300	90	185	230	205	320	151	64	28	60	5	50	31	8	
	AD4/P	345	291		118	195	280	220	280	214	83	38	80	5	70	41	10	
	AD5/P	430	355		153	195	250	225	325	287	113	42	110	10	70	45	12	
RX..107	AD3/P	230	240	350	90	210	320	225	320	145	64	28	60	5	50	31	8	
	AD4/P	345	291		118	220	280	270	360	208	83	38	80	5	70	41	10	
	AD5/P	430	355		153	220	325	275	325	281	113	42	110	10	70	45	12	
	AD6/P	495	457		163	245	310	250	310	321	114	48	110	10	80	51.5	14	

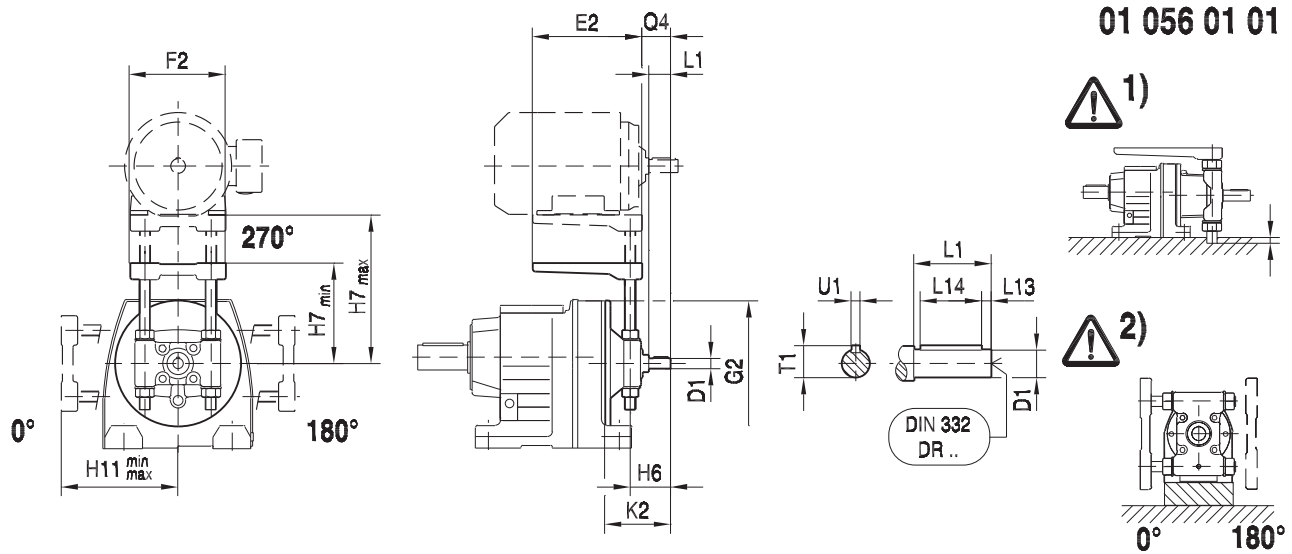

01 056 01 01

		E2	F2	G2	H6	H7 min	H7 max	H11 min	H11 max	K2	Q4	D1	L1	L13	L14	T1	U1	Δ_{131}
R..27	AD2/P	195	180	120	65	100	165	120	165	130	43	19	40	4	32	21.5	6	1), 2)
R..37	AD2/P	195	180	120	65	110	165	120	165	130	43	19	40	4	32	21.5	6	1), 2)
R..47	AD2/P	195	180	160	65	125	165	135	165	123	43	19	40	4	32	21.5	6	
	AD3/P	230	240		80	130	175	140	175	159	54	24	50	5	40	27	8	1), 2)
R..57	AD2/P	195	180	160	65	125	165	145	200	123	43	19	40	4	32	21.5	6	
	AD3/P	230	240		80	130	175	155	230	159	54	24	50	5	40	27	8	1), 2)
R..67	AD2/P	195	180	160	65	125	165	155	200	123	43	19	40	4	32	21.5	6	
	AD3/P	230	240		80	130	175	160	230	159	54	24	50	5	40	27	8	1), 2)
R..77	AD2/P	195	180	200	65	135	200	165	200	116	43	19	40	4	32	21.5	6	1)
	AD3/P	230	240		80	145	175	170	230	151	54	24	50	5	40	27	8	
	AD4/P	345	291		118	150	210	175	210	224	83	38	80	5	70	41	10	1), 2)
R..87	AD2/P	195	180	250	65	155	200	195	260	111	43	19	40	4	32	21.5	6	
	AD3/P	230	240		90	165	230	185	230	156	64	28	60	5	50	31	8	
	AD4/P	345	291		118	165	210	205	280	219	83	38	80	5	70	41	10	
	AD5/P	430	355		153	210	250	215	250	292	113	42	110	10	70	45	12	1), 2)
R..97	AD3/P	230	240	300	90	180	230	235	320	151	64	28	60	5	50	31	8	
	AD4/P	345	291		118	190	280	240	280	214	83	38	80	5	70	41	10	
	AD5/P	430	355		153	190	250	245	325	287	113	42	110	10	70	45	12	
R..107	AD3/P	230	240	350	90	230	320	230	320	145	64	28	60	5	50	31	8	
	AD4/P	345	291		118	230	280	265	360	208	83	38	80	5	70	41	10	
	AD5/P	430	355		153	225	325	270	325	281	113	42	110	10	70	45	12	1)
	AD6/P	495	457		163	245	310	250	310	321	114	48	110	10	80	51.5	14	
R..137	AD4/P	345	291	400	118	245	280	280	360	201	83	38	80	5	70	41	10	
	AD5/P	430	355		153	245	325	285	325	274	113	42	110	10	70	45	12	1)
	AD6/P	495	457		163	270	335	275	335	314	114	48	110	10	80	51.5	14	
R..147	AD4/P	345	291	450	118	270	360	315	360	193	83	38	80	5	70	41	10	
	AD5/P	430	355		153	275	325	330	405	266	113	42	110	10	70	45	12	
	AD6/P	495	457		163	295	360	310	360	306	114	48	110	10	80	51.5	14	
	AD7/P	650	570		170	300	365	300	365	300	112	55	110	10	90	59	16	3)
R..167	AD5/P	430	355	550	153	345	405	385	495	258	113	42	110	10	70	45	12	
	AD6/P	495	457		163	375	475	375	475	298	114	48	110	10	80	51.5	14	
	AD7/P	650	570		170	375	475	380	475	292	112	55	110	10	90	59	16	

8.9 R.. AR.. [dimensions]

R.. AR..

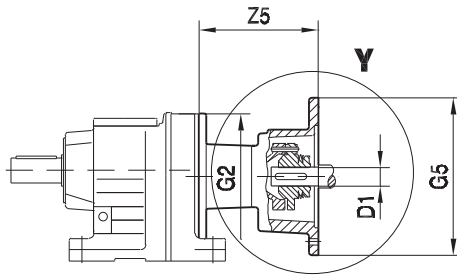
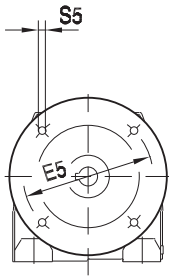

01 052 02 01

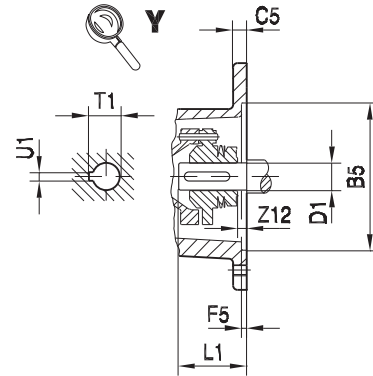

R.. AR../W

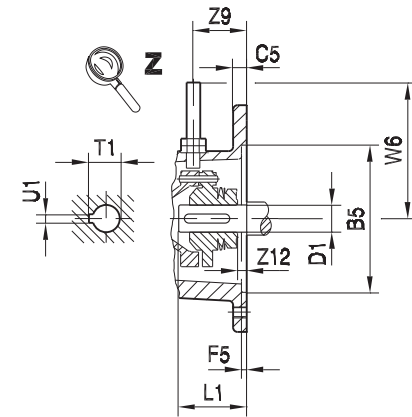
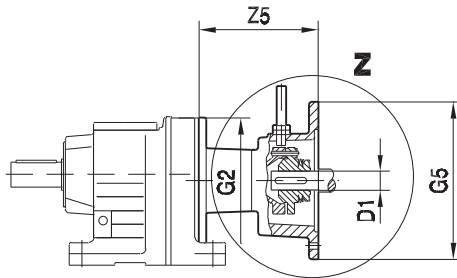
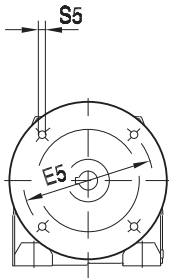

		B5	C5	E5	F5	G2	G5	S5	W6	Z5	Z9	Z12	D1	L1	T1	U1		
R..27 R..37	AR71	110	10	130	3.5	120	160	M8	120	104	37	0	14	30	16.3	5		
	AR80	130	12	165	4.5		200	M10		140.5			19	40	21.8	6		
	AR90						24	50		27.3			8					
R..47 R..57 R..67	AR71	110	10	130	3.5	160	160	M8	120	97.5	37	0	14	30	16.3	5		
	AR80	130	12	165	4.5		200	M10		134			19	40	21.8	6		
	AR90						24	50		27.3			8					
	AR100	180	15	215	5		250	M12		174.5			52	5.5	28	60	31.3	8
	AR112						28	60		31.3			8					
R..77	AR71	110	10	130	3.5	200	160	M8	120	91.5	37	0	14	30	16.3	5		
	AR80	130	12	165	4.5		200	M10		127			19	40	21.8	6		
	AR90						24	50		27.3			8					
	AR100	180	15	215	5		250	M12		166.5			52	5.5	28	60	31.3	8
	AR112						28	60		31.3			8					
	AR132S/M	230	16	265	5		300	M12		145			234	72	5	38	80	41.3
AR132ML	230	16	265	5	300	M12	145	234	72	5	38	80	41.3	10				
R..87	AR80	130	12	165	4.5	250	200	M10	120	122	37	0	19	40	21.8	6		
	AR90						24	50		27.3			8					
	AR100	180	15	215	5		250	M12	130	161.5	52	5.5	28	60	31.3	8		
	AR112						28	60		31.3			8					
	AR132S/M	230	16	265	5		300	M12	145	229	72	5	38	80	41.3	10		
	AR132ML						38	80		41.3			10					
	AR160	250	18	300	6		350	M16	165	306.5	105	35	42	110	45.3	12		
AR180	48					110	51.8	14										

R.. AR..

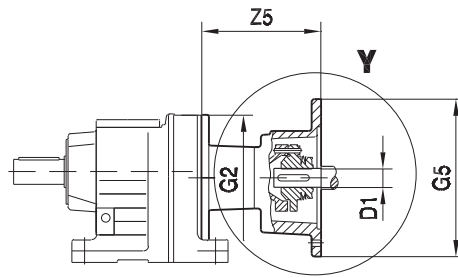
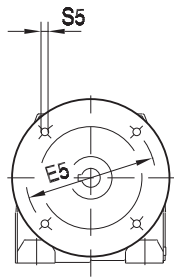

01 053 02 01

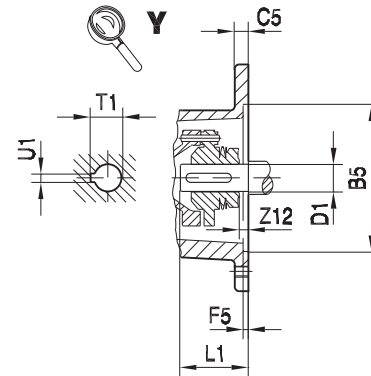

R.. AR../W

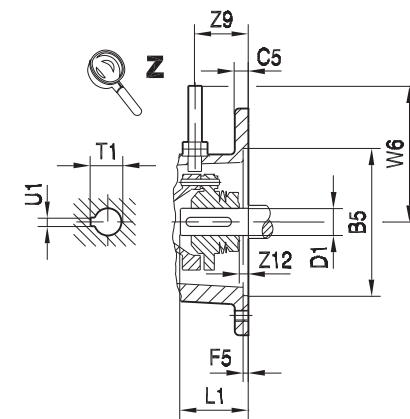
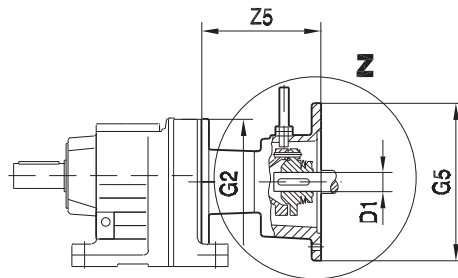
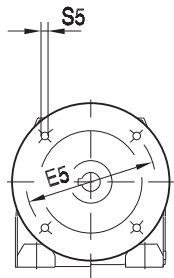

8

		B5	C5	E5	F5	G2	G5	S5	W6	Z5	Z9	Z12	D1	L1	T1	U1
R..97	AR100	180	15	215	5	300	250	M12	130	156.5	52	5.5	28	60	31.3	8
	AR112															
	AR132S/M	230	16	265	5		300	M12	145	224	72	5	38	80	41.3	10
	AR132ML															
	AR160															
AR180	250	18	300	6	350	M16	165	301.5	105	35	42	110	45.3	12		
		48	110	51.8	14											
R..107	AR100	180	15	215	5	350	250	M12	130	150.5	52	5.5	28	60	31.3	8
	AR112															
	AR132S/M	230	16	265	5		300	M12	145	218	72	5	38	80	41.3	10
	AR132ML															
	AR160															
AR180	250	18	300	6	350	M16	165	295.5	105	35	42	110	45.3	12		
		48	110	51.8	14											
R..137	AR132S/M	230	16	265	5	400	300	M12	145	211	72	5	38	80	41.3	10
	AR132ML															
	AR160	250	18	300	6		350	M16	165	288.5	105	35	42	110	45.3	12
	AR180												48	110	51.8	14
R..147	AR132S/M	230	16	265	5	450	300	M12	145	203	72	5	38	80	41.3	10
	AR132ML															
	AR160	250	18	300	6		350	M16	165	280.5	105	35	42	110	45.3	12
	AR180												48	110	51.8	14
R..167	AR160	250	18	300	6	550	350	M16	165	272.5	105	35	42	110	45.3	12
	AR180												48	110	51.8	14

8.10 Output shaft sizes

8.10.1 Solid shafts - Inch

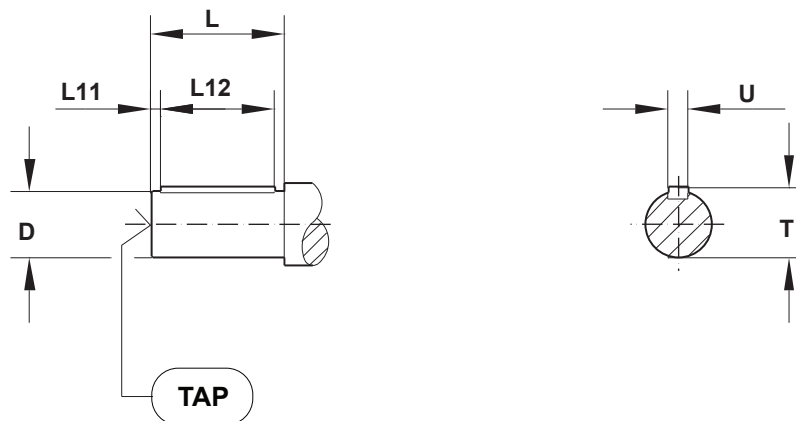

Model	All dimensions in inches							
	D	T	U	L ¹⁾	L11	L12	TAP	Change ²⁾
R..17	0.75	0.83	3/16	1.57	0.25	1-1/16	1/4 - 20 x 0.63	0
R..27	1	1.11	1/4	1.97	0.26	1-5/16	3/8 - 16 x 0.87	0
R..37	1	1.11	1/4	1.97	0.26	1-5/16	3/8 - 16 x 0.87	0
R..47	1.25	1.36	1/4	2.36	0.26	1-11/16	1/2 - 13 x 1.12	0
R..57	1.25	1.36	1/4	2.36	0.28	1-11/16	1/2 - 13 x 1.12	-0.4
	1.375	1.51	5/16	2.76	0.43	1-13/16	1/2 - 13 x 1.12	0
R..67	1.375	1.51	5/16	2.76	0.43	1-13/16	1/2 - 13 x 1.12	0
R..77	1.625	1.79	3/8	3.15	0.38	2-1/4	5/8 - 11 x 1.38	0
R..87	2.125	2.35	1/2	3.94	0.64	2-5/8	3/4 - 10 x 1.61	0
R..97	2.375	2.65	5/8	4.72	0.51	3-5/8	3/4 - 10 x 1.61	0
R..107	2.875	3.2	3/4	5.51	0.67	4-1/8	3/4 - 10 x 1.61	0
R..137	3.625	4.01	7/8	6.69	0.63	5-3/8	1 - 8 x 2.13	0
R..147	4.375	4.82	1	8.27	1.09	6	1 - 8 x 2.13	0
R..167	4.75	5.29	1-1/4	8.27	0.82	6-9/16	1 - 8 x 2.13	0
RX..57	0.75	0.83	3/16	1.57	0.23	1-1/16	1/4 - 20 x 0.63	0
RX..67	1	1.11	1/4	1.97	0.26	1-5/16	3/8 - 16 x 0.87	0
RX..77	1.25	1.36	1/4	2.36	0.26	1-11/16	1/2 - 13 x 1.12	0
	1.625	1.79	3/8	3.15	0.38	2-1/4	5/8 - 11 x 1.38	+0.79
RX..87	1.625	1.79	3/8	3.15	0.38	2-1/4	5/8 - 11 x 1.38	0
	1.75	1.92	3/8	3.54	0.38	2-3/4	5/8 - 11 x 1.38	+0.39
RX..97	2.125	2.35	1/2	3.94	0.64	2-5/8	3/4 - 10 x 1.61	0
RX..107	2.375	2.65	5/8	4.72	0.51	3-5/8	3/4 - 10 x 1.61	0

1) Longer shafts to match obsolete gear unit designs (ie: RF60/RF62/RF63) are available for flanged units.

2) The change in length, L, when compared to the standard shaft that is shown in dimension pages.

8.10.2 Solid shafts - Metric

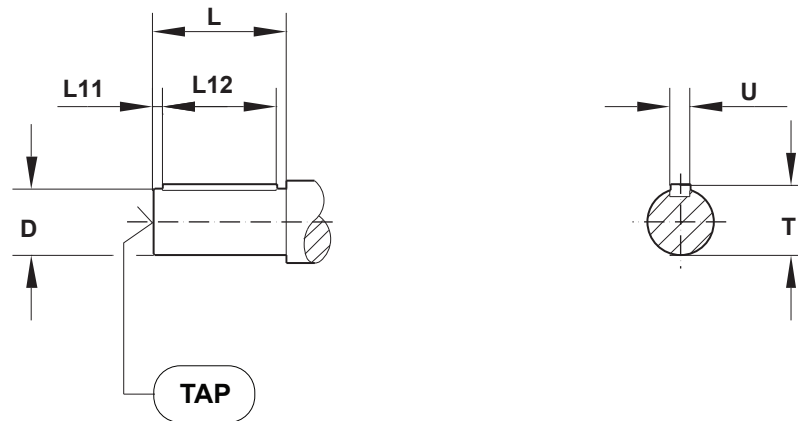

Model	All dimensions in mm						
	D	T	U	L ¹⁾	L11	L12	TAP
R..17	20	22.5	6	40	4	32	M6 x 16
R..27	25	28	8	50	3.5	40	M10 x 22
R..37	25	28	8	50	3.5	50	M10 x 22
R..47	30	33	8	60	3.5	50	M10 x 22
R..57	30	33	8	60	7	50	M10 x 22
	35	38	10	70	7	56	M12 x 28
R..67	35	38	10	70	7	56	M12 x 28
R..77	40	43	12	80	5	70	M16 x 36
R..87	50	53.5	14	100	10	80	M16 x 36
R..97	60	64	18	120	5	110	M20 x 42
R..107	70	74.5	20	140	7.5	125	M20 x 42
R..137	90	95	25	170	5	160	M24 x 50
R..147	110	116	28	210	15	180	M24 x 50
R..167	120	127	32	210	5	200	M24 x 50
RX..57	20	22.5	6	40	3.5	32	M6 x 16
RX..67	25	28	8	50	3.5	40	M10 x 22
RX..77	30	33	8	60	3.5	50	M10 x 22
	40	43	12	80	5	70	M16 x 36
RX..87	40	43	12	80	5	70	M16 x 36
	45	48.5	14	90	5	80	M16 x 36
RX..97	50	53.5	14	100	10	80	M16 x 36
RX..107	60	64	18	120	5	110	M20 x 42

1) Longer shafts to match obsolete gear unit designs (ie: RF60/RF62/RF63) are available for flanged units.

8

R / RX - Helical Output shaft sizes

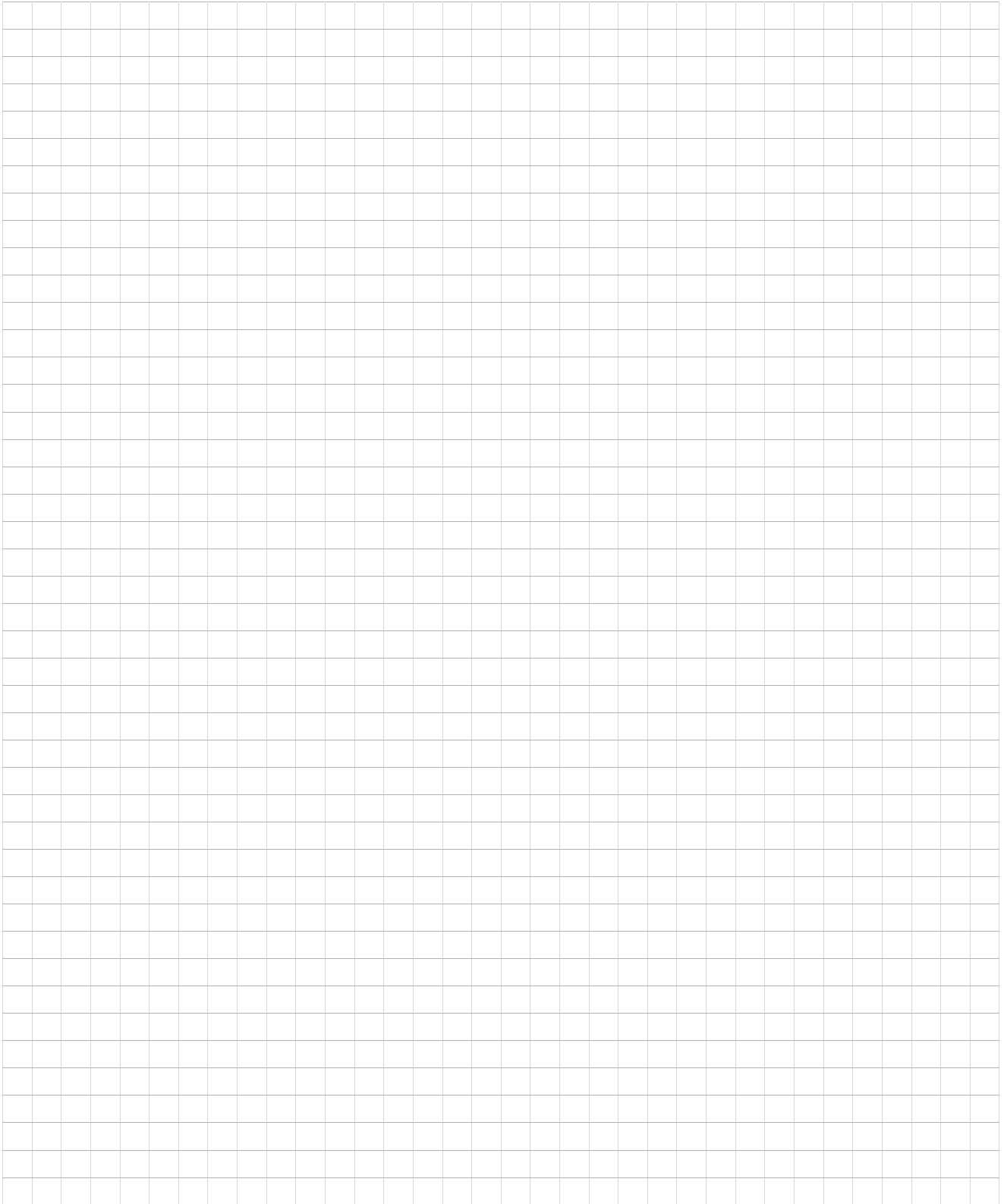

9 F - theSnuggler® Helical

9.1 F.. AM

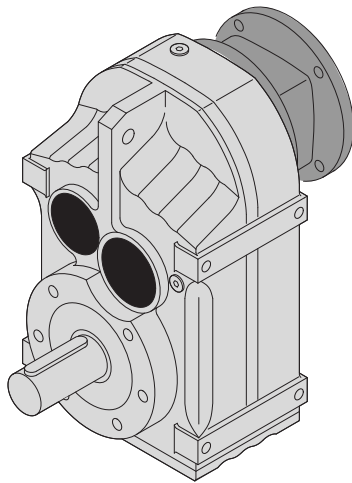

F.. AM..

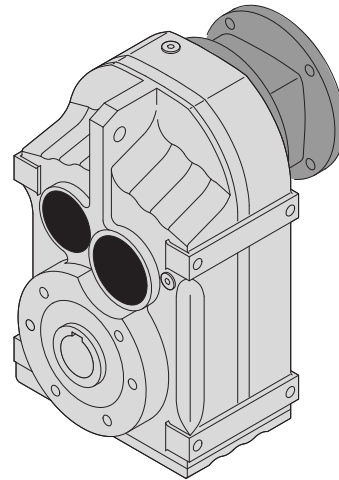

FA..B AM..
FV..B AM..

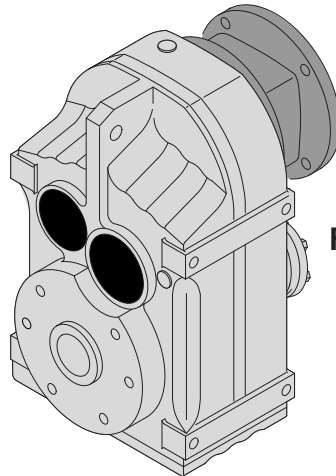

FH..B AM..

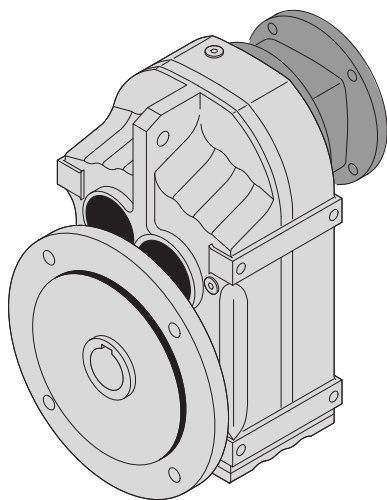

FAF.. AM..
FVF.. AM ..

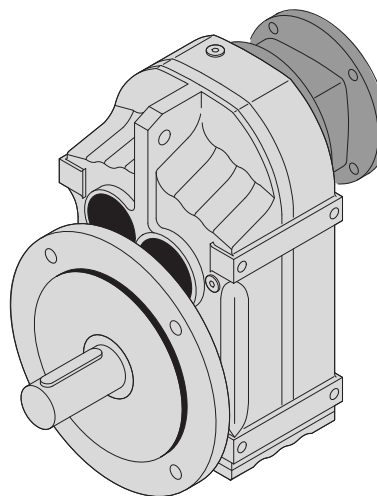

FF.. AM..

50397AXX

9 F - theSnuggler® Helical
F.. AM

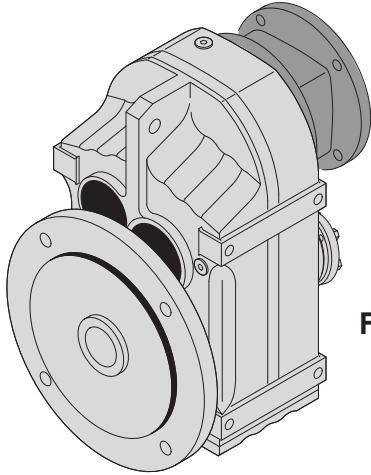

FHF .. AM..

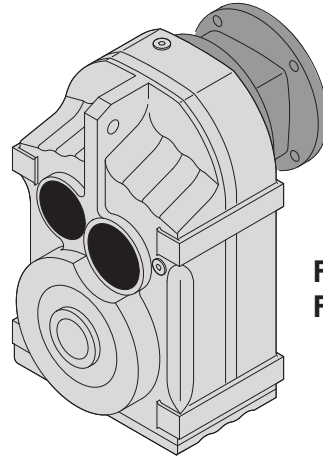

FA.. AM..
FV.. AM..

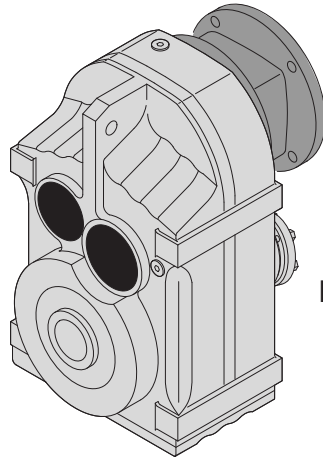

FH.. AM..

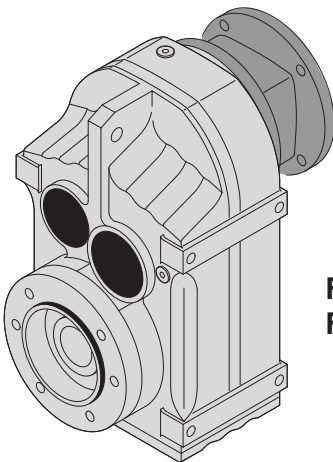

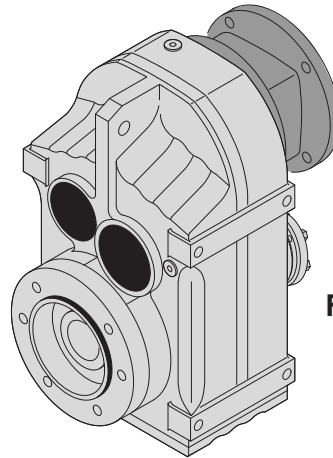

FAZ.. AM..
FVZ.. AM..



FHZ.. AM..

50398AXX

9.1.1 F27

F27, n _e = 1700 rpm						1150 lb-in		
Stages	i [ratio]	n _a [rpm]	T _{a max} [lb-in]	F _{Ra} [lb]	Φ (/R) [']	AM		
						56	143	145
F27  2	4.16	409	765	280	-			
	4.93	345	840	285	-			
	5.27	323	880	290	-			
	6.17	276	960	295	-			
	6.91	246	1000	305	-			
	8.13	209	1080	315	-			
	9.40	181	1150	330	-			
	9.88	172	1150	370	-			
	10.55	161	1150	385	-			
	12.35	138	1150	420	-			
	13.84	123	1150	445	-			
	16.28	104	1150	485	-			
	18.84	90	1150	520	-			
	20.15	84	1150	540	-			
	23.25	73	1150	575	-			
	27.18	63	1150	620	-			
29.56	58	1150	645	-				
F27  3	33.83	50	1150	690	-			
	38.33	44	1150	730	-			
	40.89	42	1150	750	-			
	46.78	36	1150	795	-			
	50.19	34	1150	820	-			
	56.62	30	1150	870	-			
	63.86	27	1150	910	-			
	72.37	23	1150	960	-			
	77.21	22	1150	990	-			
	88.32	19	1150	1010	-			
	94.76	18	1150	1010	-			
	109.90	15	1150	1010	-			
129.09	13	1150	1010	-				
140.74	12	1150	1010	-				

9



Weight [lbs]		Stages	56	AM 143	145
F27	NEMA	2	20	24	24
		3	20	25	25
			71	80	90
	IEC	2	19	24	24
		3	20	25	25

FA27: -1 lb / FAF27: +1 lb / FF27: +2 lbs

9 F - theSnuggler® Helical

F.. AM



9.1.2 F37

F37, n _e = 1700 rpm						1770 lb-in		
Stages	i [ratio]	n _a [rpm]	T _{a max} [lb-in]	F _{Ra} [lb]	Φ (°/R) [']	AM		
						56	143	145
F37  2	3.77	451	920	400	12			
	4.22	403	970	415	11			
	4.90	347	1060	425	11			
	5.21	326	1100	430	10			
	6.05	281	1190	445	10			
	6.74	252	1230	460	10			
	7.44	228	1280	475	10			
	8.01	212	1500	475	7			
	8.97	190	1540	500	7			
	10.42	163	1630	520	7			
	11.08	153	1680	530	7			
	12.87	132	1770	555	7			
	14.33	119	1770	590	6			
	15.81	108	1770	625	6			
	17.03	100	1770	645	6			
	19.27	88	1770	690	6			
	20.57	83	1770	715	6			
23.63	72	1770	765	6				
F37  3	23.88	71	1770	770	8			
	28.09	61	1770	830	8			
	31.69	54	1770	880	8			
	35.91	47	1770	930	8			
	38.31	44	1770	960	8			
	43.83	39	1770	960	8			
	47.02	36	1770	960	8			
	51.70	33	1770	960	7			
	54.54	31	1770	960	8			
	58.32	29	1770	960	7			
	66.09	26	1770	960	7			
	70.50	24	1770	960	7			
	80.65	21	1770	960	7			
	86.53	20	1770	960	7			
	100.36	17	1770	960	7			
117.88	14	1770	960	7				
128.51	13	1770	960	7				

Weight [lbs]		Stages	56	AM 143	145
F37	NEMA	2	33	38	38
		3	34	38	38
			71	80	90
	IEC	2	33	38	38
		3	33	38	38

FA37: -1 lb / FAF37: +2 lbs / FF37: +4 lbs

9.1.3 F47

F47, n _e = 1700 rpm						3530 lb-in		
Stages	i [ratio]	n _a [rpm]	T _{a max} [lb-in]	F _{Ra} [lb]	Φ (°/R) [']	56	AM 143	145
F47  2	4.99	341	2830	450	9			
	5.76	295	3000	465	9			
	6.34	268	3090	485	8			
	7.44	228	3360	490	8			
	7.88	216	3360	515	8			
	8.96	190	2910	650	8			
	10.97	155	3530	685	6			
	12.66	134	3530	750	6			
	13.93	122	3530	795	6			
	16.36	104	3530	870	6			
	17.33	98	3530	900	6			
	19.70	86	3530	970	6			
	21.82	78	3530	1020	6			
	25.72	66	3530	1110	6			
29.32	58	3530	1190	6				
30.86	55	3530	1220	6				
F47  3	28.88	59	3530	1180	7			
	34.29	50	3530	1290	7			
	36.61	46	3530	1330	7			
	42.86	40	3530	1330	7			
	48.00	35	3530	1330	7			
	56.49	30	3530	1330	7			
	65.36	26	3530	1330	7			
	68.09	25	3530	1330	6			
	79.72	21	3530	1330	6			
	89.29	19	3530	1330	6			
	105.09	16	3530	1330	6			
	121.57	14	3530	1330	6			
	130.07	13	3530	1330	6			
	150.06	11	3530	1330	6			
175.38	9.7	3530	1330	6				
190.76	8.9	3530	1330	6				



Weight [lbs]		Stages	56	AM 143	145
F47	NEMA	2	43	48	48
		3	45	50	50
			71	80	90
	IEC	2	43	48	48
		3	44	50	50

FA47: -2 lb / FAF47: +4 lbs / FF47: +7 lbs

9 F - theSnuggler® Helical

F.. AM

9.1.4 F57

F57, n _e = 1700 rpm						5310 lb-in					
Stages	i [ratio]	n _a [rpm]	T _{a max} [lb-in]	F _{Ra} [lb]	Φ (i/R) [']	AM					
						56	143	145	182	184	213/215
F57  2	5.18	328	3670	690	9						
	5.98	284	3710	745	9						
	6.58	258	3710	790	8						
	7.73	220	3710	870	8						
	8.19	208	3710	900	8						
	9.31	183	3710	960	8						
	10.64	160	5310	860	6						
	12.29	138	5310	940	6						
	13.52	126	5310	1000	6						
	15.88	107	5310	1100	6						
	16.81	101	5310	1130	6						
	19.11	89	5310	1220	6						
	21.17	80	5310	1290	6						
	24.96	68	5080	1440	6						
	28.45	60	4730	1590	6						
	29.94	57	4820	1620	6						
34.24	50	4420	1780	6							
40.13	42	2560	2200	6							
F57  3	30.15	56	5220	1560	7						
	35.79	47	5310	1690	7						
	38.21	44	5310	1740	7						
	44.73	38	5310	1880	7						
	50.10	34	5310	1980	7						
	58.97	29	5310	2070	7						
	68.22	25	5310	2070	6						
	72.98	23	5310	2070	6						
	83.46	20	5310	2070	6						
	93.47	18	5310	2070	6						
	110.01	15	5310	2070	6						
	127.27	13	5310	2070	6						
	136.16	12	5310	2070	6						
	157.09	11	5310	2070	6						
183.60	9.3	5310	2070	6							
199.70	8.5	5310	2070	6							

Weight [lbs]		Stages	AM					
			56	143	145	182	184	213/215
F57	NEMA	2	59	64	64	72	72	84
		3	61	65	65	73	73	86
		71	80	90	100	112	132S/M	
	IEC	2	59	64	64	74	74	89
		3	60	65	65	75	75	91

FA57: -1 lb / FAF57: +11 lbs / FF57: +14 lbs

9.1.5 F57R37

F57R37, n _e = 1700 rpm							5310 lb-in		
i [ratio]	n _a [rpm]	T _{a max} [lb-in]	F _{Ra} ¹⁾ [lb]	Stages		φ (/R) [']	AM		
				Lg	Sm		56	143	145
134	13	5310	2070	2	2	-			
152	11	5310	2070	2	2	-			
155	11	5310	2070	3	2	-			
170	10	5310	2070	2	2	-			
181	9.4	5310	2070	3	2	-			
200	8.5	5310	2070	2	2	-			
201	8.5	5310	2070	3	2	-			
226	7.5	5310	2070	2	2	-			
255	6.7	5310	2070	3	2	-			
262	6.5	5310	2070	2	2	-			
298	5.7	5310	2070	2	2	-			
330	5.2	5310	2070	2	2	-			
338	5.0	5310	2070	3	2	-			
382	4.5	5310	2070	2	2	-			
386	4.4	5310	2070	3	2	-			
426	4.0	5310	2070	2	2	-			
452	3.8	5310	2070	3	2	-			
483	3.5	5310	2070	2	3	-			
506	3.4	5310	2070	3	2	-			
549	3.1	5310	2070	2	3	-			
558	3.0	5310	2070	3	2	-			
646	2.6	5310	2070	3	2	-			
658	2.6	5310	2070	2	3	-			
738	2.3	5310	2070	3	2	-			
749	2.3	5310	2070	2	3	-			
851	2.0	5310	2070	3	2	-			
856	2.0	5310	2070	2	3	-			
949	1.8	5310	2070	2	3	-			
967	1.8	5310	2070	3	2	-			
1066	1.6	5310	2070	2	3	-			
1106	1.5	5310	2070	3	2	-			
1238	1.4	5310	2070	3	3	-			
1243	1.4	5310	2070	2	3	-			
1422	1.2	5310	2070	2	3	-			
1439	1.2	5310	2070	3	3	-			
1617	1.1	5310	2070	2	3	-			
1623	1.0	5310	2070	3	3	-			
1791	0.95	5310	2070	2	3	-			
1840	0.92	5310	2070	3	3	-			
2012	0.84	5310	2070	2	3	-			
2131	0.80	5310	2070	3	3	-			
2266	0.75	5310	2070	2	3	-			
2409	0.71	5310	2070	3	3	-			
2576	0.66	5310	2070	2	3	-			
2737	0.62	5310	2070	3	3	-			
2854	0.60	5310	2070	2	3	-			
3161	0.54	5310	2070	3	3	-			
3564	0.48	5310	2070	3	3	-			
4060	0.42	5310	2070	3	3	-			
4654	0.37	5310	2070	3	3	-			
5289	0.32	5310	2070	3	3	-			

9 F - theSnuggler® Helical



F.. AM

F57R37, $n_e = 1700$ rpm							5310 lb-in		
i [ratio]	n_a [rpm]	T_a max [lb-in]	$F_{Ra}^{1)}$ [lb]	Stages		ϕ (/R) [']	AM		
				Lg	Sm		56	143	145
6030	0.28	5310	2070	3	3	-			
6913	0.25	5310	2070	3	3	-			
7908	0.21	5310	2070	3	3	-			
8787	0.19	5310	2070	3	3	-			
9986	0.17	5310	2070	3	3	-			
11252	0.15	5310	2070	3	3	-			
12602	0.13	5310	2070	3	3	-			
13604	0.12	5310	2070	3	3	-			
14832	0.11	5310	2070	3	3	-			

Weight [lbs]		Stages		AM			
		Large	Small	56	143	145	
F57R37	NEMA	2	2	83	87	87	
		2	3	83	88	88	
		3	2	84	88	88	
		3	3	84	89	89	
					71	80	90
	IEC	2	2	82	87	87	
		2	3	82	88	88	
		3	2	83	88	88	
		3	3	84	89	89	

FA57: -1 lb / FAF57: +11 lbs / FF57: +14 lbs

9.1.6 F67

F67, n _e = 1700 rpm						7250 lb-in					
Stages	i [ratio]	n _a [rpm]	T _{a max} [lb-in]	F _{Ra} [lb]	Φ (°/R) [']	AM					
						56	143	145	182	184	213/215
F67  2	3.97	428	4420	1740	10						
	4.66	365	4950	1780	9						
	5.25	324	5220	1830	9						
	5.95	286	5390	1910	9						
	6.78	251	5480	2000	9						
	7.53	226	5390	2100	8						
	8.60	198	5040	2270	8						
	9.08	187	4680	2370	8						
	9.66	176	7260	2240	6						
	11.31	150	7260	2320	6						
	12.76	133	7260	2320	6						
	14.46	118	7260	2320	6						
	16.48	103	7260	2320	6						
	18.29	93	7260	2320	6						
	20.90	81	7260	2320	5						
	22.05	77	7260	2320	5						
	25.13	68	7260	2320	5						
	27.41	62	7260	2320	5						
32.08	53	7260	2320	5							
36.30	47	7260	2320	5							
F67  3	34.01	50	7260	2470	6						
	39.26	43	7260	2390	6						
	43.20	39	7260	2320	6						
	50.74	34	7260	2320	6						
	53.73	32	7260	2320	6						
	61.07	28	7260	2320	6						
	67.65	25	7260	2320	6						
	79.76	21	7260	2320	6						
	90.59	19	7260	2320	6						
	95.94	18	7260	2320	6						
	109.04	16	7260	2320	6						
	120.79	14	7260	2320	6						
	142.40	12	7260	2320	6						
	162.31	10	7260	2320	6						
	170.85	10.0	7260	2320	6						
195.39	8.7	7260	2320	6							
228.99	7.4	7260	2320	6							

Weight [lbs]		Stages	AM					
			56	143	145	182	184	213/215
F67	NEMA	2	73	77	77	85	85	97
		3	75	79	79	87	88	100
			71	80	90	100	112	132S/M
	IEC	2	72	77	77	87	87	103
		3	74	79	79	90	90	105
	FA67: -6 lbs / FAF67: +8 lbs / FF67: +13 lbs							

9 F - theSnuggler® Helical

F.. AM

9.1.7 F67R37

F67R37, n _e = 1700 rpm							7260 lb-in		
i [ratio]	n _a [rpm]	T _{a max} [lb-in]	F _{Ra} ¹⁾ [lb]	Stages		Φ (/R) [']	AM		
				Lg	Sm		56	143	145
175	9.7	7260	2320	3	2	-			
176	9.7	7260	2320	2	2	-			
200	8.5	7260	2320	2	2	-			
205	8.3	7260	2320	3	2	-			
231	7.4	7260	2320	3	2	-			
238	7.1	7260	2320	2	2	-			
257	6.6	7260	2320	3	2	-			
261	6.5	7260	2320	2	2	-			
297	5.7	7260	2320	2	2	-			
305	5.6	7260	2320	3	2	-			
333	5.1	7260	2320	2	2	-			
338	5.0	7260	2320	3	2	-			
384	4.4	7260	2320	3	2	-			
392	4.3	7260	2320	2	2	-			
437	3.9	7260	2320	3	2	-			
454	3.7	7260	2320	2	2	-			
500	3.4	7260	2320	2	2	-			
509	3.3	7260	2320	3	2	-			
539	3.2	7260	2320	2	3	-			
572	3.0	7260	2320	3	2	-			
634	2.7	7260	2320	2	3	-			
641	2.7	7260	2320	3	2	-			
722	2.4	7260	2320	2	3	-			
755	2.3	7260	2320	3	2	-			
858	2.0	7260	2320	3	2	-			
864	2.0	7260	2320	2	3	-			
970	1.8	7260	2320	3	2	-			
984	1.7	7260	2320	2	3	-			
1102	1.5	7260	2320	3	2	-			
1126	1.5	7260	2320	2	3	-			
1256	1.4	7260	2320	2	3	-			
1271	1.3	7260	2320	3	2	-			
1429	1.2	7260	2320	3	2	-			
1437	1.2	7260	2320	2	3	-			
1631	1.0	7260	2320	2	3	-			
1635	1.0	7260	2320	3	2	-			
1859	0.91	7260	2320	2	3	-			
1884	0.90	7260	2320	3	2	-			
2106	0.81	7260	2320	3	2	-			
2126	0.80	7260	2320	2	3	-			
2372	0.72	7260	2320	2	3	-			
2439	0.70	7260	2320	3	3	-			
2714	0.63	7260	2320	2	3	-			
2756	0.62	7260	2320	3	3	-			
2912	0.58	7260	2320	2	3	-			
3133	0.54	7260	2320	3	3	-			
3377	0.50	7260	2320	2	3	-			
3574	0.48	7260	2320	3	3	-			
4091	0.42	7260	2320	3	3	-			
4690	0.36	7260	2320	3	3	-			
5341	0.32	7260	2320	3	3	-			

F67R37, $n_e = 1700$ rpm 7260 lb-in

i [ratio]	n_a [rpm]	$T_{a \max}$ [lb-in]	$F_{Ra}^{1)}$ [lb]	Stages		ϕ (/R) [']	56	AM	
				Lg	Sm			143	145
6080	0.28	7260	2320	3	3	-			
7096	0.24	7260	2320	3	3	-			
7940	0.21	7260	2320	3	3	-			
8933	0.19	7260	2320	3	3	-			
10220	0.17	7260	2320	3	3	-			
11480	0.15	7260	2320	3	3	-			
12926	0.13	7260	2320	3	3	-			
14992	0.11	7260	2320	3	3	-			
17610	0.10	7260	2320	3	3	-			
19199	0.09	7260	2320	3	3	-			



Weight [lbs]		Stages		56	AM	
		Large	Small		143	145
F67R37	NEMA	2	2	96	100	100
		2	3	96	101	101
		3	2	98	103	103
		3	3	99	103	103
				71	80	90
	IEC	2	2	95	100	100
		2	3	95	101	101
		3	2	97	103	103
		3	3	98	103	103

FA67: -6 lbs / FAF67: +8 lbs / FF67: +13 lbs

9 F - theSnuggler® Helical

F.. AM

9.1.8 F77

F77, n _e = 1700 rpm						13280 lb-in					
Stages	i [ratio]	n _a [rpm]	T _a max [lb-in]	F _{Ra} [lb]	Φ (f/R) [']	AM					
						56	143	145	182	184	213/215
F77  2	4.28	397	8930	2100	8						
	5.16	329	9550	2210	8						
	5.76	295	9550	2320	8						
	6.64	256	9550	2470	8						
	7.39	230	9550	2590	7						
	8.26	206	9550	2720	7						
	9.30	183	9550	2860	7						
	10.93	156	13280	2950	6						
	12.20	139	13280	3090	5						
	14.06	121	13280	3280	5						
	15.64	109	13280	3420	5						
	17.49	97	13280	3530	5						
	19.70	86	13280	3530	5						
	21.43	79	13280	3530	5						
	25.50	67	13280	3530	5						
	28.75	59	12600	3640	5						
	31.51	54	12200	3700	5						
	36.58	46	9820	4010	5						
F77  3	25.54	67	12800	3610	6						
	29.91	57	13280	3530	6						
	33.74	50	13280	3530	6						
	38.23	44	13280	3530	6						
	43.58	39	13280	3530	6						
	48.37	35	13280	3530	6						
	55.27	31	13280	3530	6						
	58.32	29	13280	3530	6						
	66.46	26	13280	3530	6						
	72.50	23	13280	3530	6						
	75.02	23	13280	3530	6						
	85.52	20	13280	3530	6						
	94.93	18	13280	3530	5						
	108.46	16	13280	3530	5						
	114.45	15	13280	3530	5						
	130.42	13	13280	3530	5						
	142.27	12	13280	3530	5						
	166.47	10	13280	3530	5						
	188.40	9.0	13280	3530	5						
	198.31	8.6	13280	3530	5						
225.79	7.5	13280	3530	5							
262.93	6.5	13280	3530	5							
281.71	6.0	13280	3530	5							

Weight [lbs]		Stages	AM					
			56	143	145	182	184	213/215
F77	NEMA	2	125	129	129	136	136	149
		3	127	132	132	139	139	152
			71	80	90	100	112	132S/M
	IEC	2	124	129	129	138	138	154
		3	127	132	132	141	141	157

FA77: -9 lbs / FAF77: +6 lbs / FF77: +23 lbs

9.1.9 F77R37

F77R37, n _e = 1700 rpm							13280 lb-in		
i [ratio]	n _a [rpm]	T _{a max} [lb-in]	F _{Ra} ¹⁾ [lb]	Stages		φ (°R) [']	56	AM	
				Lg	Sm			143	145
199	8.5	13280	3540	3	2	-			
221	7.7	13280	3540	3	2	-			
247	6.9	13280	3540	3	2	-			
280	6.1	13280	3540	3	2	-			
292	5.8	9820	4010	2	2	-			
323	5.3	13280	3540	3	2	-			
346	4.9	9820	4010	2	2	-			
367	4.6	13280	3540	3	2	-			
370	4.6	9820	4010	2	2	-			
413	4.1	13280	3540	3	2	-			
433	3.9	9820	4010	2	2	-			
480	3.5	13280	3540	3	2	-			
485	3.5	9820	4010	2	2	-			
538	3.2	13280	3540	3	2	-			
571	3.0	9820	4010	2	2	-			
615	2.8	13280	3540	3	2	-			
660	2.6	9820	4010	2	2	-			
706	2.4	9820	4010	2	2	-			
710	2.4	13280	3540	3	2	-			
810	2.1	13280	3540	3	2	-			
815	2.1	9820	4010	2	2	-			
893	1.9	9820	4010	2	3	-			
910	1.9	13280	3540	3	2	-			
1051	1.6	9820	4010	2	3	-			
1053	1.6	13280	3540	3	2	-			
1185	1.4	9820	4010	2	3	-			
1200	1.4	13280	3540	3	2	-			
1343	1.3	9820	4010	2	3	-			
1354	1.3	13280	3540	3	2	-			
1433	1.2	9820	4010	2	3	-			
1544	1.1	13280	3540	3	2	-			
1639	1.0	9820	4010	2	3	-			
1728	0.98	13280	3540	3	2	-			
1759	0.97	9820	4010	2	3	-			
2029	0.84	13280	3540	3	3	-			
2039	0.83	9820	4010	2	3	-			
2238	0.76	9820	4010	2	3	-			
2284	0.74	13280	3540	3	3	-			
2536	0.67	9820	4010	2	3	-			
2613	0.65	13280	3540	3	3	-			
2705	0.63	9820	4010	2	3	-			
2978	0.57	13280	3540	3	3	-			
3095	0.55	9820	4010	2	3	-			
3320	0.51	9820	4010	2	3	-			
3381	0.50	13280	3540	3	3	-			
3832	0.44	13280	3540	3	3	-			
3851	0.44	9820	4010	2	3	-			
4435	0.38	13280	3540	3	3	-			
4523	0.38	9820	4010	2	3	-			
4931	0.34	9820	4010	2	3	-			
5026	0.34	13280	3540	3	3	-			

9 F - theSnuggler® Helical

F.. AM

F77R37, n _e = 1700 rpm							13280 lb-in		
i [ratio]	n _a [rpm]	T _{a max} [lb-in]	F _{Ra} ¹⁾ [lb]	Stages		φ (/R) [']	56	AM	
				Lg	Sm			143	145
5808	0.29	13280	3540	3	3	-			
6580	0.26	13280	3540	3	3	-			
7520	0.23	13280	3540	3	3	-			
8464	0.20	13280	3540	3	3	-			
9683	0.18	13280	3540	3	3	-			
11035	0.15	13280	3540	3	3	-			
12049	0.14	13280	3540	3	3	-			
13731	0.12	13280	3540	3	3	-			
14978	0.11	13280	3540	3	3	-			
16128	0.11	13280	3540	3	3	-			
17593	0.10	13280	3540	3	3	-			
19180	0.09	13280	3540	3	3	-			

Weight [lbs]		Stages		56	AM		
		Large	Small		143	145	
F77R37	NEMA	2	2	146	151	151	
		2	3	147	151	152	
		3	2	149	154	154	
		3	3	150	154	155	
					71	80	90
	IEC	2	2	146	151	151	
		2	3	146	151	152	
		3	2	149	154	154	
		3	3	149	154	155	

FA77: -9 lbs / FAF77: +6 lbs / FF77: +23 lbs

9.1.10 F87

F87, n _e = 1700 rpm						26600 lb-in						
Stages	i [ratio]	n _a [rpm]	T _{a max} [lb-in]	F _{Ra} [lb]	φ (i/R) [']	AM						
						143	145	182	184	213/215	254/256	284/286
F87  2	4.12	413	12900	1170	7							
	4.92	346	13500	1260	7							
	5.63	302	13500	1390	7							
	6.65	256	13500	1550	7							
	7.35	231	13500	1650	7							
	8.29	205	13500	1780	7							
	9.58	177	25400	910	7							
	11.46	148	26600	1010	7							
	13.12	130	26600	1180	7							
	15.48	110	26600	1390	7							
	17.12	99	26600	1530	7							
	19.31	88	26600	1700	7							
	21.32	80	26600	1840	7							
	23.68	72	26600	2000	7							
	26.50	64	26600	2180	7							
	28.78	59	21600	2790	7							
	33.92	50	23000	2930	7							
29.20	58	22200	2760	8								
35.19	48	23000	2990	8								
39.30	43	24000	3090	8								
45.28	38	24900	3270	8								
50.36	34	26000	3370	7								
56.75	30	26600	3560	7								
68.40	25	26600	3960	7								
76.39	22	26600	4200	7								
88.01	19	26600	4450	7								
97.89	17	26600	4450	7								
109.49	16	26600	4450	7								
123.29	14	26600	4450	7								
134.16	13	26600	4450	7								
159.61	11	26600	4450	7								
179.97	9.4	26600	4450	7								
197.20	8.6	26600	4450	7								
228.93	7.4	26600	4450	7								
255.37	6.7	26600	4450	7								
270.68	6.3	26600	4450	7								

Weight [lbs]		Stages	AM						
			143	145	182	184	213/215	254/256	284/286
F87	NEMA	2	215	216	225	225	238	268	272
		3	222	222	231	231	245	274	279
		80	90	100	112	132S/M	160	180	
	IEC	2	215	216	227	227	243	279	279
		3	222	222	233	233	249	285	285
	FA87: -13 lbs / FAF87: +15 lbs / FF87: +34 lbs								

9 F - theSnuggler® Helical

F.. AM

9.1.11 F87R57

F87R57, $n_e = 1700$ rpm							26600 lb-in					
i [ratio]	n_a [rpm]	$T_{a\ max}$ [lb-in]	$F_{Ra}^{1)}$ [lb]	Stages		Φ (/R) [']	AM					
				Lg	Sm		56	143	145	182	184	213/215
211	8.1	26600	4450	2	2	-						
240	7.1	26600	4450	2	2	-						
249	6.8	26600	4450	3	2	-						
281	6.0	26600	4450	2	2	-						
300	5.7	26600	4450	3	2	-						
315	5.4	26600	4450	2	2	-						
345	4.9	26600	4450	3	2	-						
350	4.9	26600	4450	2	2	-						
398	4.3	26600	4450	2	2	-						
452	3.8	26600	4450	3	2	-						
468	3.6	26600	4450	2	2	-						
515	3.3	26600	4450	3	2	-						
519	3.3	26600	4450	2	2	-						
592	2.9	26600	4450	2	2	-						
609	2.8	26600	4450	3	2	-						
662	2.6	26600	4450	2	2	-						
674	2.5	26600	4450	3	2	-						
748	2.3	26600	4450	2	3	-						
780	2.2	26600	4450	3	2	-						
883	1.9	26600	4450	2	3	-						
887	1.9	26600	4450	3	2	-						
988	1.7	26600	4450	2	3	-						
1010	1.7	26600	4450	3	2	-						
1142	1.5	26600	4450	2	3	-						
1148	1.5	26600	4450	3	2	-						
1278	1.3	26600	4450	2	3	-						
1300	1.3	26600	4450	3	2	-						
1476	1.2	26600	4450	2	3	-						
1493	1.1	26600	4450	3	2	-						
1709	0.99	26600	4450	3	2	-						
1717	0.99	26600	4450	2	3	-						
1913	0.89	26600	4450	2	3	-						
1930	0.88	26600	4450	3	2	-						
2134	0.80	26600	4450	2	3	-						
2199	0.77	26600	4450	3	2	-						
2524	0.67	26600	4450	2	3	-						
2576	0.66	26600	4450	3	2	-						
2857	0.60	26600	4450	2	3	-						
2881	0.59	26600	4450	3	2	-						
3196	0.53	26600	4450	2	3	-						
3244	0.52	26600	4450	3	2	-						
3503	0.49	26600	4450	2	3	-						
3721	0.46	26600	4450	3	3	-						
3919	0.43	26600	4450	2	3	-						
4245	0.40	26600	4450	3	3	-						
4562	0.37	26600	4450	2	3	-						
4952	0.34	26600	4450	2	3	-						
4954	0.34	26600	4450	3	3	-						
5510	0.31	26600	4450	3	3	-						
6273	0.27	26600	4450	3	3	-						
7100	0.24	26600	4450	3	3	-						

F87R57, n_e = 1700 rpm 26600 lb-in

i [ratio]	n _a [rpm]	T _{a max} [lb-in]	F _{Ra} ¹⁾ [lb]	Stages		ϕ (/R) [']	AM					
				Lg	Sm		56	143	145	182	184	213/215
8142	0.21	26600	4450	3	3	-						
9381	0.18	26600	4450	3	3	-						
10433	0.16	26600	4450	3	3	-						
12205	0.14	26600	4450	3	3	-						
14099	0.12	26600	4450	3	3	-						
15877	0.11	26600	4450	3	3	-						
18238	0.09	26600	4450	3	3	-						
20462	0.08	26600	4450	3	3	-						
23042	0.07	26600	4450	3	3	-						



Weight [lbs]		Stages		AM						
		Large	Small	56	143	145	182	184	213/215	
F87R57	NEMA	2	2	262	267	267	275	275	287	
		2	3	264	269	269	277	277	289	
		3	2	269	273	273	281	281	294	
		3	3	271	275	275	283	283	296	
					71	80	90	100	112	132S/M
	IEC	2	2	262	267	267	277	277	293	
		2	3	264	269	269	279	279	295	
		3	2	268	273	273	283	283	299	
		3	3	270	275	275	285	285	301	

FA87: -13 lbs / FAF87: +15 lbs / FF87: +34 lbs

9 F - theSnuggler® Helical

F.. AM

9.1.12 F97

F97, n _e = 1700 rpm						38100 lb-in						
Stages	i [ratio]	n _a [rpm]	T _{a max} [lb-in]	F _{Ra} [lb]	φ (/R) [']	AM						
						182	184	213/215	254/256	284/286	324/326	364/365
F97  2	3.87	439	15900	2000	9							
	4.57	372	18100	1980	9							
	5.23	325	19000	2070	9							
	6.17	276	19900	2200	9							
	7.07	240	20800	2300	9							
	8.22	207	20800	2530	8							
	9.06	188	20800	2680	9							
	11.16	152	36200	1910	6							
	12.77	133	38100	1990	6							
	15.06	113	38100	2300	6							
	17.25	99	38100	2560	6							
	20.07	85	38100	2870	6							
	22.11	77	38100	3070	6							
	24.92	68	38100	3340	6							
	27.44	62	38100	3550	6							
	30.39	56	38100	3800	6							
	33.91	50	38100	4060	6							
36.64	46	27100	5230	6								
43.28	39	27100	5660	6								
F97  3	32.50	52	38100	3960	6							
	38.86	44	38100	4410	6							
	44.49	38	38100	4770	6							
	52.49	32	38100	5230	6							
	58.06	29	38100	5520	6							
	65.47	26	38100	5890	6							
	72.29	24	38100	6200	6							
	75.63	22	38100	6350	6							
	80.31	21	38100	6540	6							
	86.59	20	38100	6720	6							
	89.85	19	38100	6720	6							
	97.58	17	38100	6720	6							
	102.16	17	38100	6720	6							
	112.99	15	38100	6720	6							
	127.42	13	38100	6720	6							
	140.71	12	38100	6720	6							
	156.30	11	38100	6720	6							
174.87	9.7	38100	6720	6								
189.92	9.0	38100	6720	6								
223.88	7.6	38100	6720	6								
253.41	6.7	38100	6720	6								
276.77	6.1	38100	6720	6								

Weight [lbs]		Stages	AM						
			182	184	213/215	254/256	284/286	324/326	364/365
F97	NEMA	2	365	365	376	409	414	452	451
		3	378	378	389	422	427	465	464
			100	112	132S/M	160	180	200	225
	IEC	2	367	367	380	420	420	456	467
3		380	380	393	433	433	469	480	

FA97: -17 lbs / FAF97: +31 lbs / FF97: +72 lbs

9.1.13 F97R57

F97R57, n _e = 1700 rpm							38100 lb-in					
i [ratio]	n _a [rpm]	T _{a max} [lb-in]	F _{Ra} ¹⁾ [lb]	Stages		Φ (/R) [']	AM					
				Lg	Sm		56	143	145	182	184	213/215
195	8.7	38100	6720	3	2	-						
208	8.2	38100	6720	3	2	-						
242	7.0	38100	6720	2	2	-						
245	6.9	38100	6720	3	2	-						
275	6.2	38100	6720	2	2	-						
285	6.0	38100	6720	3	2	-						
317	5.4	38100	6720	2	2	-						
361	4.7	38100	6720	2	2	-						
363	4.7	38100	6720	3	2	-						
403	4.2	38100	6720	2	2	-						
406	4.2	38100	6720	3	2	-						
467	3.6	38100	6720	3	2	-						
473	3.6	38100	6720	2	2	-						
510	3.3	38100	6720	2	2	-						
529	3.2	38100	6720	3	2	-						
569	3.0	38100	6720	2	2	-						
605	2.8	38100	6720	3	2	-						
667	2.5	38100	6720	2	2	-						
690	2.5	38100	6720	3	2	-						
760	2.2	38100	6720	2	2	-						
784	2.2	38100	6720	3	2	-						
892	1.9	38100	6720	2	2	-						
898	1.9	38100	6720	3	2	-						
1022	1.7	38100	6720	3	2	-						
1023	1.7	38100	6720	2	3	-						
1171	1.5	38100	6720	3	2	-						
1189	1.4	38100	6720	2	3	-						
1316	1.3	38100	6720	2	3	-						
1327	1.3	38100	6720	3	2	-						
1468	1.2	38100	6720	2	3	-						
1527	1.1	38100	6720	3	2	-						
1722	0.99	38100	6720	3	2	-						
1741	0.98	38100	6720	2	3	-						
1970	0.86	38100	6720	3	2	-						
1971	0.86	38100	6720	2	3	-						
2199	0.77	38100	6720	2	3	-						
2245	0.76	38100	6720	3	2	-						
2448	0.69	38100	6720	2	3	-						
2553	0.67	38100	6720	3	2	-						
2907	0.58	38100	6720	3	2	-						
3009	0.56	38100	6720	2	3	-						
3352	0.51	38100	6720	3	2	-						
3357	0.51	38100	6720	2	3	-						
3906	0.44	38100	6720	3	2	-						
3914	0.43	38100	6720	2	3	-						
4333	0.39	38100	6720	3	3	-						
4367	0.39	38100	6720	2	3	-						
4961	0.34	38100	6720	3	3	-						
5016	0.34	38100	6720	2	3	-						
5615	0.30	38100	6720	3	3	-						
5680	0.30	38100	6720	2	3	-						

9 F - theSnuggler® Helical



F.. AM

F97R57, n _e = 1700 rpm							38100 lb-in					
i [ratio]	n _a [rpm]	T _a max [lb-in]	F _{Ra} ¹⁾ [lb]	Stages		Φ (/R) [']	AM					
				Lg	Sm		56	143	145	182	184	213/215
6338	0.27	38100	6720	2	3	-						
6469	0.26	38100	6720	3	3	-						
7328	0.23	38100	6720	3	3	-						
8318	0.20	38100	6720	3	3	-						
9576	0.18	38100	6720	3	3	-						
10838	0.16	38100	6720	3	3	-						
12324	0.14	38100	6720	3	3	-						
14022	0.12	38100	6720	3	3	-						
15472	0.11	38100	6720	3	3	-						
18119	0.09	38100	6720	3	3	-						
20813	0.08	38100	6720	3	3	-						
23814	0.07	38100	6720	3	3	-						
26911	0.06	38100	6720	3	3	-						
29211	0.06	38100	6720	3	3	-						

Weight [lbs]		Stages		AM					
		Large	Small	56	143	145	182	184	213/215
F97R57	NEMA	2	2	404	408	408	416	416	429
		2	3	406	410	410	418	418	431
		3	2	417	421	421	429	429	442
		3	3	419	423	423	431	431	
				71	80	90	100	112	132S/M
	IEC	2	2	403	408	408	418	418	434
		2	3	405	410	410	420	420	436
		3	2	416	421	421	431	431	447
		3	3	418	423	423	433	433	

FA97: -17 lbs / FAF97: +31 lbs / FF97: +72 lbs

9.1.14 F107

F107, n _e = 1700 rpm						69400 lb-in						
Stages	i [ratio]	n _a [rpm]	T _{a max} [lb-in]	F _{Ra} [lb]	Φ (/R) [']	AM						
						182	184	213/215	254/256	284/286	324/326	364/365
F107  2	5.03	338	40700	3140	7							
	6.22	273	40700	3730	7							
	7.40	230	40700	4220	7							
	8.37	203	42400	4350	7							
	9.69	175	43400	4660	7							
	9.96	171	57500	4180	5							
	12.33	138	61900	4390	5							
	14.67	116	67900	4300	5							
	16.58	103	69400	4600	5							
	19.20	89	69400	5170	5							
	21.76	78	69400	5670	5							
	25.14	68	69400	6260	5							
	27.57	62	69400	6640	5							
33.79	50	65400	7880	5								
F107  3	31.80	53	67900	7390	6							
	37.61	45	67900	8110	6							
	43.03	40	67900	8640	6							
	50.73	34	67900	9300	6							
	58.12	29	67900	9880	6							
	67.62	25	67900	10600	6							
	74.52	23	67900	11000	6							
	83.99	20	67900	11200	6							
	88.49	19	67900	11200	5							
	92.47	18	67900	11200	6							
	101.38	17	67900	11200	5							
	117.94	14	67900	11200	5							
	129.97	13	67900	11200	5							
	146.49	12	67900	11200	5							
	161.28	11	67900	11200	5							
	178.64	9.5	67900	11200	5							
199.31	8.5	67900	11200	5								
215.37	7.9	67900	11200	5								
254.40	6.7	67900	11200	5								

Weight [lbs]		Stages	AM						
			182	184	213/215	254/256	284/286	324/326	364/365
F107	NEMA	2	542	542	546	582	587	625	625
		3	564	564	568	604	609	647	647
			100	112	132S/M	160	180	200	225
	IEC	2	544	545	550	593	593	629	640
3		566	566	572	615	615	651	662	

FA107: -37 lbs / FAF107: +10 lbs / FF107: +60 lbs

9 F - theSnuggler® Helical

F.. AM

9.1.15 F107R77

F107R77, $n_e = 1700$ rpm							69400 lb-in					
i [ratio]	n_a [rpm]	$T_{a \max}$ [lb-in]	$F_{Ra}^{(1)}$ [lb]	Stages		ϕ (/R) [']	AM					
				Lg	Sm		56	143	145	182	184	213/215
190	8.9	67970	11200	3	2	-						
225	7.6	67970	11200	3	2	-						
255	6.7	67970	11200	3	2	-						
266	6.4	69400	11100	2	2	-						
291	5.8	67970	11200	3	2	-						
300	5.7	69400	11100	2	2	-						
333	5.1	67970	11200	3	2	-						
340	5.0	69400	11100	2	2	-						
370	4.6	67970	11200	3	2	-						
387	4.4	69400	11100	2	2	-						
430	4.0	69400	11100	2	2	-						
436	3.9	67970	11200	3	2	-						
489	3.5	67970	11200	3	2	-						
491	3.5	69400	11100	2	2	-						
518	3.3	69400	11100	2	2	-						
560	3.0	67970	11200	3	2	-						
591	2.9	69400	11100	2	2	-						
640	2.7	67970	11200	3	2	-						
644	2.6	69400	11100	2	2	-						
696	2.4	69400	11100	2	3	-						
736	2.3	67970	11200	3	2	-						
800	2.1	69400	11100	2	3	-						
834	2.0	67970	11200	3	2	-						
923	1.8	69400	11100	2	3	-						
950	1.8	67970	11200	3	2	-						
1015	1.7	69400	11100	2	3	-						
1087	1.6	67970	11200	3	2	-						
1193	1.4	69400	11100	2	3	-						
1243	1.4	67970	11200	3	2	-						
1263	1.3	69400	11100	2	3	-						
1401	1.2	67970	11200	3	2	-						
1436	1.2	69400	11100	2	3	-						
1590	1.1	69400	11100	2	3	-						
1597	1.1	67970	11200	3	2	-						
1813	0.94	69400	11100	2	3	-						
1826	0.93	67970	11200	3	2	-						
2068	0.82	67970	11200	3	2	-						
2129	0.80	69400	11100	2	3	-						
2255	0.75	69400	11100	2	3	-						
2369	0.72	67970	11200	3	2	-						
2563	0.66	69400	11100	2	3	-						
2756	0.62	67970	11200	3	2	-						
2839	0.60	69400	11100	2	3	-						
3037	0.56	67970	11200	3	2	-						
3347	0.51	69400	11100	2	3	-						
3521	0.48	67970	11200	3	3	-						
3815	0.45	69400	11100	2	3	-						
3948	0.43	67970	11200	3	3	-						
4016	0.42	69400	11100	2	3	-						
4567	0.37	67970	11200	3	3	-						
4593	0.37	69400	11100	2	3	-						

F107R77, n_e = 1700 rpm 69400 lb-in

i [ratio]	n _a [rpm]	T _{a max} [lb-in]	F _{Ra} ¹⁾ [lb]	Stages		φ (fR) [']	AM					
				Lg	Sm		56	143	145	182	184	213/215
5223	0.33	67970	11200	3	3	-						
5383	0.32	69400	11100	2	3	-						
5954	0.29	67970	11200	3	3	-						
6767	0.25	67970	11200	3	3	-						
7674	0.22	67970	11200	3	3	-						
8548	0.20	67970	11200	3	3	-						
10039	0.17	67970	11200	3	3	-						
11348	0.15	67970	11200	3	3	-						
14767	0.12	67970	11200	3	3	-						
16888	0.10	67970	11200	3	3	-						
18933	0.09	67970	11200	3	3	-						
21652	0.08	67970	11200	3	3	-						
25375	0.07	67970	11200	3	3	-						

Weight [lbs]		Stages		AM						
		Large	Small	56	143	145	182	184	213/215	
F107R77	NEMA	2	2	613	617	618	625	625	638	
		2	3	616	620	620	627	627	641	
		3	2	635	639	639	647	647	660	
		3	3	638	642	642	649	649	662	
					71	80	90	100	112	132S/M
	IEC	2	2	613	617	618	627	627	643	
		2	3	615	620	620	630	630	645	
		3	2	634	639	639	649	649	664	
3		3	637	642	642	651	651	667		



FA107: -37 lbs / FAF107: +10 lbs / FF107: +60 lbs

9 F - theSnuggler® Helical

F.. AM

9.1.16 F127

F127, n_e = 1700 rpm 106200 lb-in

Stages	i [ratio]	n _a [rpm]	T _{a max} [lb-in]	F _{Ra} [lb]	φ (/R) [']	AM				
						213/215	254/256	284/286	324/326	364/365
F127  2	4.68	363	53000	6060	7					
	5.52	308	53000	6540	7					
	6.80	250	61900	6610	7					
	7.88	216	53000	7650	6					
	8.86	192	61900	7490	6					
	10.19	167	84000	6060	5					
	12.54	136	88400	6550	5					
	14.55	117	97300	6340	5					
	16.36	104	97300	6930	5					
	18.87	90	97300	7680	5					
	21.38	80	106200	7440	5					
	24.57	69	75200	11000	5					
26.86	63	75200	11500	5						
F127  3	25.30	67	106200	8400	5					
	31.33	54	106200	9660	5					
	37.28	46	106200	10700	5					
	42.15	40	106200	11500	5					
	48.80	35	106200	12500	5					
	55.31	31	106200	13300	5					
	63.91	27	106200	14300	5					
	70.07	24	106200	14900	5					
	75.41	23	106200	15400	5					
	87.31	19	106200	16400	5					
	98.95	17	106200	17200	5					
	114.34	15	106200	18300	5					
	125.37	14	106200	19000	5					
	153.67	11	106200	20200	5					
170.83	10.0	106200	20200	5						

Weight [lbs]		Stages	AM				
			213/215	254/256	284/286	324/326	364/365
F127	NEMA	2	923	946	951	985	984
		3	950	973	978	1011	1011
			132S/M	160/180	200	225	250/280
	IEC	2	928	957	989	1000	1070
		3	954	984	1016	1026	1097

FA127: -80 lbs / FAF127: +2 lbs / FF127: +98 lbs

9.1.17 F127R77

F127R77, n _e = 1700 rpm							106200 lb-in					
i [ratio]	n _a [rpm]	T _{a max} [lb-in]	F _{Ra} ¹⁾ [lb]	Stages		φ (/R) [']	AM					
				Lg	Sm		56	143	145	182	184	213/215
376	4.5	106200	20230	3	2	-						
428	4.0	106200	20230	3	2	-						
495	3.4	106200	20230	3	2	-						
549	3.1	106200	20230	3	2	-						
648	2.6	106200	20230	3	2	-						
727	2.3	106200	20230	3	2	-						
820	2.1	106200	20230	3	2	-						
930	1.8	106200	20230	3	2	-						
1077	1.6	106200	20230	3	2	-						
1220	1.4	106200	20230	3	2	-						
1390	1.2	106200	20230	3	2	-						
1606	1.1	106200	20230	3	2	-						
1784	0.95	106200	20230	3	2	-						
2038	0.83	106200	20230	3	2	-						
2357	0.72	106200	20230	3	2	-						
2672	0.64	106200	20230	3	2	-						
3031	0.56	106200	20230	3	3	-						
3454	0.49	106200	20230	3	3	-						
3926	0.43	106200	20230	3	3	-						
4533	0.38	106200	20230	3	3	-						
5153	0.33	106200	20230	3	3	-						
5925	0.29	106200	20230	3	3	-						
6715	0.25	106200	20230	3	3	-						
7643	0.22	106200	20230	3	3	-						
8831	0.19	106200	20230	3	3	-						
10191	0.17	106200	20230	3	3	-						
11656	0.15	106200	20230	3	3	-						
12912	0.13	106200	20230	3	3	-						
14722	0.12	106200	20230	3	3	-						
16656	0.10	106200	20230	3	3	-						
19048	0.09	106200	20230	3	3	-						
22323	0.08	106200	20230	3	3	-						
24478	0.07	106200	20230	3	3	-						

Weight [lbs]		Stages		AM					
		Large	Small	56	143	145	182	184	213/215
F127R77	NEMA	3	2	1012	1016	1016	1024	1024	1037
		3	3	1014	1019	1019	1026	1026	1039
			71	80	90	100	112	132S/M	
	IEC	3	2	1011	1016	1016	1026	1026	1041
3		3	1014	1019	1019	1028	1028	1044	

FA127: -80 lbs / FAF127: +2 lbs / FF127: +98 lbs



9.1.18 F127R87

F127R87, n_e = 1700 rpm							106200 lb-in						
i [ratio]	n _a [rpm]	T _{a max} [lb-in]	F _{Ra} ¹⁾ [lb]	Stages		φ (/R) [']	AM						
				Lg	Sm		143	145	182	184	213/215	254/256	284/286
166	10	106200	20230	3	2	-							
198	8.6	106200	20230	3	2	-							
223	7.6	106200	20230	3	2	-							
259	6.6	106200	20230	3	2	-							
293	5.8	106200	20230	3	2	-							
312	5.4	106200	20230	3	2	-							
374	4.5	106200	20230	3	2	-							
418	4.1	106200	20230	3	2	-							
483	3.5	106200	20230	3	2	-							

Weight [lbs]		Stages		143	145	182	AM			
		Large	Small				184	213/215	254/256	284/286
F127R87	NEMA	3	2	1061	1061	1070	1070	1084	1113	1118
				80	90	100	112	132S/M	160	180
	IEC	3	2	1061	1061	1072	1072	1088	1124	1124

FA127: -80 lbs / FAF127: +2 lbs / FF127: +98 lbs

9.1.19 F157

F157, n _e = 1700 rpm						159300 lb-in			
Stages	i [ratio]	n _a [rpm]	T _{a max} [lb-in]	F _{Ra} [lb]	Φ (°/R) [']	AM			
						254/256	284/286	324/326	364/365
F157  2	11.92	143	141500	8270	5				
	13.96	122	150400	8570	5				
	16.85	101	159300	9060	5				
	19.77	86	150400	10400	4				
	22.16	77	159300	10500	4				
	25.43	67	132700	12700	4				
	28.60	59	150400	12500	4				
	35.75	48	97300	16500	4				
	43.94	39	88400	18400	4				
	53.55	32	70700	20600	4				
F157  3	27.60	62	159300	11800	5				
	32.55	52	159300	12800	5				
	40.06	42	159300	14100	5				
	46.48	37	159300	15200	5				
	52.24	33	159300	16000	5				
	60.25	28	159300	17000	5				
	68.28	25	159300	18000	5				
	78.46	22	159300	19100	5				
	85.80	20	159300	19800	5				
	96.53	18	159300	20800	5				
	108.49	16	159300	21900	5				
	125.14	14	159300	22500	5				
	141.80	12	159300	22500	5				
	162.96	10	159300	22500	5				
	178.20	9.5	159300	22500	5				
217.62	7.8	159300	22500	5					
267.43	6.4	159300	22500	5					

Weight [lbs]		Stages	AM			
			254/256	284/286	324/326	364/365
F157	NEMA	2	1490	1495	1540	1540
		3	1503	1508	1553	1553
			160/180	200	225	250/280
	IEC	2	1502	1544	1555	1610
		3	1515	1558	1568	1623

FA157: -46 lbs / FAF157: +84 lbs / FF157: +236 lbs

9.1.20 F157R97

F157R97, n_e = 1700 rpm							159300 lb-in						
i [ratio]	n _a [rpm]	T _a max [lb-in]	F _{Ra} ¹⁾ [lb]	Stages		φ (/R) [']	AM						
				Lg	Sm		182	184	213/215	254/256	284/286	324/326	364/365
197	8.6	159300	22540	3	2	-							
202	8.4	159300	22540	3	2	-							
232	7.3	159300	22540	3	2	-							
273	6.2	159300	22540	3	2	-							
302	5.6	159300	22540	3	2	-							
353	4.8	159300	22540	3	2	-							
446	3.8	159300	22540	3	2	-							
503	3.4	159300	22540	3	2	-							
576	3.0	159300	22540	3	2	-							
680	2.5	159300	22540	3	2	-							
764	2.2	159300	22540	3	2	-							
845	2.0	159300	22540	3	2	-							
953	1.8	159300	22540	3	2	-							
1169	1.5	159300	22540	3	2	-							
1308	1.3	159300	22540	3	2	-							
1441	1.2	159300	22540	3	3	-							
1674	1.0	159300	22540	3	2	-							
1944	0.87	159300	22540	3	2	-							
2185	0.78	159300	22540	3	2	-							
2427	0.70	159300	22540	3	2	-							
2780	0.61	159300	22540	3	3	-							
3210	0.53	159300	22540	3	3	-							
3607	0.47	159300	22540	3	3	-							
4130	0.41	159300	22540	3	3	-							
4831	0.35	159300	22540	3	3	-							
5404	0.31	159300	22540	3	3	-							
6295	0.27	159300	22540	3	3	-							
7075	0.24	159300	22540	3	3	-							
8026	0.21	159300	22540	3	3	-							
9021	0.19	159300	22540	3	3	-							
10033	0.17	159300	22540	3	3	-							
12235	0.14	159300	22540	3	3	-							
13751	0.12	159300	22540	3	3	-							
16358	0.10	159300	22540	3	3	-							
17984	0.09	159300	22540	3	3	-							
20212	0.08	159300	22540	3	3	-							
23464	0.07	159300	22540	3	3	-							

Weight [lbs]		Stages		AM						
		Large	Small	182	184	213/215	254/256	284/286	324/326	364/365
F157R97	NEMA	3	2	1731	1731	1743	1776	1781	1818	1818
		3	3	1738	1738	1750	1783	1787	1825	1825
	IEC			100	112	132S/M	160	180	200	225
		3	2	1734	1734	1747	1787	1787	1823	1834
		3	3	1741	1741	1754	1794	1794	1830	1840

FA157: -46 lbs / FAF157: +84 lbs / FF157: +236 lbs

9.2 F.. AD

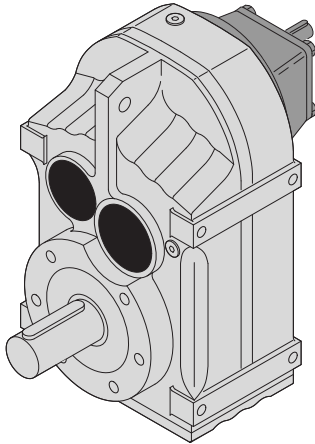

F.. AD..

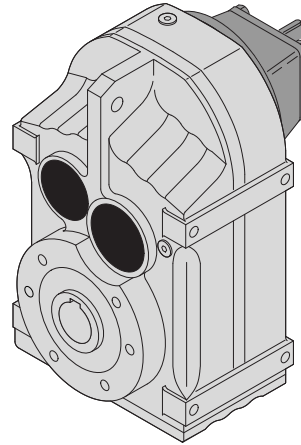

FA..B AD..
FV..B AD..

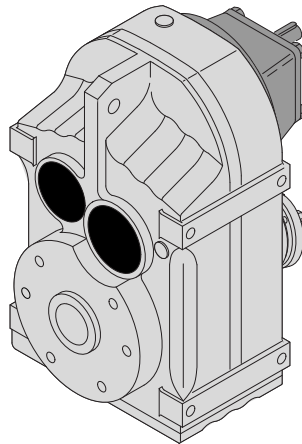

FH..B AD..

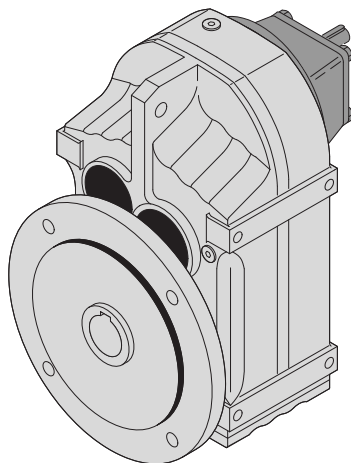

FAF.. AD..
FVF.. AD..

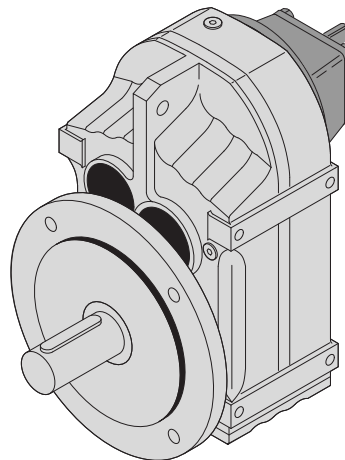

FF.. AD..

50401AXX

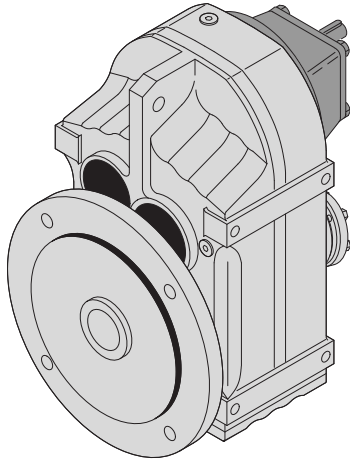

FHF .. AD ..

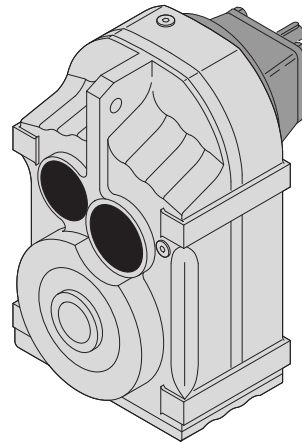

**FA.. AD..
FV.. AD..**

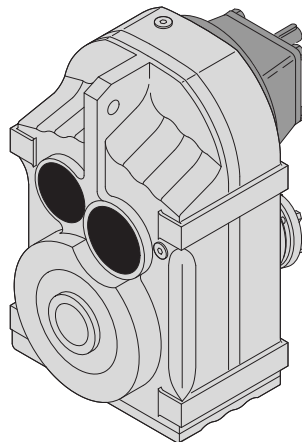

FH.. AD..

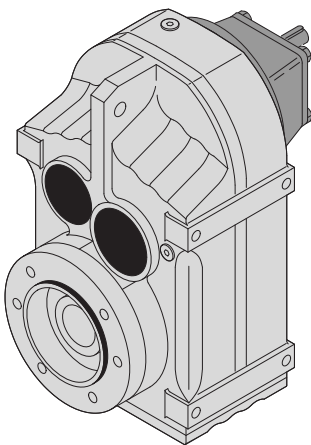

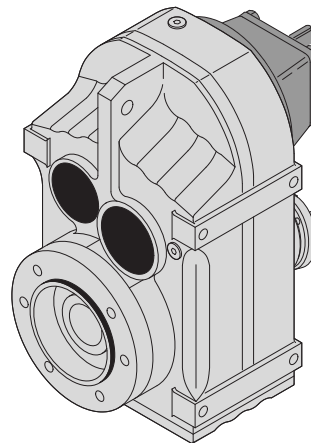

**FAZ.. AD..
FVZ.. AD..**



FHZ.. AD..

50402AXX



9.2.1 F27

F27 AD.. , n _e = 1700 rpm										1150 lb-in	
i [ratio]	n _a [rpm]	T _a max [lb-in]	P _e [HP]	F _{RA} ¹⁾ [lb]	F _{Re} [lb]	Stages		φ _(/R) [']			
						Lg	Sm				
33.83	50	1150	0.96	690	100	3	-	-	-		
38.33	44	1150	0.85	730	110	3	-	-	-		
40.89	42	1150	0.79	750	110	3	-	-	-		
46.78	36	1150	0.69	800	110	3	-	-	-		
50.19	34	1150	0.65	820	120	3	-	-	-		
56.62	30	1150	0.57	870	150	3	-	-	-		
63.86	27	1150	0.51	910	150	3	-	-	-		
72.37	23	1150	0.45	960	160	3	-	-	-		
77.21	22	1150	0.42	990	160	3	-	-	-		
88.32	19	1150	0.37	1010	160	3	-	-	-		
94.76	18	1150	0.34	1010	160	3	-	-	-		
109.90	15	1150	0.30	1010	160	3	-	-	-		
129.09	13	1150	0.25	1010	160	3	-	-	-		
140.74	12	1150	0.23	1010	160	3	-	-	-		
4.16	409	770	5.1	280	260	2	-	-	-		
4.93	345	850	4.8	290	260	2	-	-	-		
5.27	323	890	4.7	290	260	2	-	-	-		
6.17	276	960	4.3	300	250	2	-	-	-		
6.91	246	1010	4.1	310	250	2	-	-	-		
8.13	209	1090	3.7	320	250	2	-	-	-		
9.40	181	1150	3.4	330	250	2	-	-	-		
9.88	172	1150	3.2	370	310	2	-	-	-		
10.55	161	1150	3.0	380	310	2	-	-	-		
12.35	138	1150	2.6	420	310	2	-	-	-		
13.84	123	1150	2.3	440	320	2	-	-	-		
16.28	104	1150	2.0	480	320	2	-	-	-		
18.84	90	1150	1.7	520	330	2	-	-	-		
20.15	84	1150	1.6	540	200	2	-	-	-		
23.25	73	1150	1.4	580	210	2	-	-	-		
27.18	63	1150	1.2	620	220	2	-	-	-		
29.56	58	1150	1.1	650	220	2	-	-	-		
33.83	50	1150	0.96	690	360	3	-	-	-		
38.33	44	1150	0.85	730	370	3	-	-	-		
40.89	42	1150	0.79	750	370	3	-	-	-		
46.78	36	1150	0.69	800	370	3	-	-	-		
50.19	34	1150	0.65	820	370	3	-	-	-		
56.62	30	1150	0.57	870	380	3	-	-	-		
63.86	27	1150	0.51	910	380	3	-	-	-		
72.37	23	1150	0.45	960	380	3	-	-	-		
77.21	22	1150	0.42	990	380	3	-	-	-		
88.32	19	1150	0.37	1010	390	3	-	-	-		
94.76	18	1150	0.34	1010	390	3	-	-	-		
109.90	15	1150	0.30	1010	390	3	-	-	-		
129.09	13	1150	0.25	1010	390	3	-	-	-		
140.74	12	1150	0.23	1010	390	3	-	-	-		
Weight [lbs]	Stages		AD1		AD2						
	Large	Small									
FA27	2	-	17		19						
	3	-	18		20						
FA27: -1 lb / FAF27: +1 lb / FF27: +2 lbs											

9 F - theSnuggler® Helical

F.. AD



9.2.2 F37

F37 AD.. , $n_e = 1700$ rpm										1770 lb-in		
i [ratio]	n_a [rpm]	$T_{a \max}$ [lb-in]	P_e [HP]	$F_{Ra}^{(1)}$ [lb]	F_{Re} [lb]	Stages		ϕ (/R) [']			F37	AD1
						Lg	Sm					
51.70	33	1770	0.97	970	110	3	-	7	-			
54.54	31	1770	0.92	970	60	3	-	8	-			
58.32	29	1770	0.86	970	110	3	-	7	-			
66.09	26	1770	0.76	970	120	3	-	7	-			
70.50	24	1770	0.71	970	120	3	-	7	-			
80.65	21	1770	0.62	970	120	3	-	7	-			
86.53	20	1770	0.58	970	130	3	-	7	-			
100.36	17	1770	0.50	970	130	3	-	7	-			
117.88	14	1770	0.42	970	130	3	-	7	-			
128.51	13	1770	0.39	970	130	3	-	7	-			
3.77	451	930	6.9	400	220	2	-	12	-			
4.22	403	970	6.4	410	230	2	-	11	-			
4.90	347	1060	6.0	430	220	2	-	11	-			
5.21	326	1110	5.9	430	220	2	-	10	-			
6.05	281	1190	5.5	440	210	2	-	10	-			
6.74	252	1240	5.1	460	210	2	-	10	-			
7.44	228	1070	4.0	520	240	2	-	10	-			
8.01	212	1500	5.2	480	270	2	-	7	-			
8.97	190	1550	4.8	500	270	2	-	7	-			
10.42	163	1640	4.4	520	270	2	-	7	-			
11.08	153	1680	4.2	530	270	2	-	7	-			
12.87	132	1770	3.8	560	270	2	-	7	-			
14.33	119	1770	3.4	590	280	2	-	7	-			
15.81	108	1770	3.1	620	280	2	-	6	-			
17.03	100	1770	2.9	650	280	2	-	6	-			
19.27	88	1770	2.6	690	290	2	-	6	-			
20.57	83	1770	2.4	710	290	2	-	6	-			
23.63	72	1770	2.1	770	290	2	-	6	-			
23.88	71	1770	2.1	770	340	3	-	8	-			
28.09	61	1770	1.8	830	340	3	-	8	-			
31.69	54	1770	1.6	880	280	3	-	8	-			
35.91	47	1770	1.4	940	290	3	-	8	-			
38.31	44	1770	1.3	960	290	3	-	8	-			
43.83	39	1770	1.1	970	300	3	-	8	-			
47.02	36	1770	1.1	970	300	3	-	8	-			
51.70	33	1770	0.97	970	370	3	-	7	-			
54.54	31	1770	0.92	970	310	3	-	8	-			
58.32	29	1770	0.86	970	370	3	-	7	-			
66.09	26	1770	0.76	970	370	3	-	7	-			
70.50	24	1770	0.71	970	370	3	-	7	-			
80.65	21	1770	0.62	970	370	3	-	7	-			
86.53	20	1770	0.58	970	370	3	-	7	-			
100.36	17	1770	0.50	970	380	3	-	7	-			
117.88	14	1770	0.42	970	380	3	-	7	-			
128.51	13	1770	0.39	970	380	3	-	7	-			

Weight [lbs]	Stages		AD1	AD2
	Large	Small		
F37	2	-	30	33
	3	-	31	34

FA37: -1 lb / FAF37: +2 lbs / FF37: +4 lbs

9.2.3 F47

F47 AD.. , $n_e = 1700$ rpm										3540 lb-in		
i [ratio]	n_a [rpm]	$T_{a \max}$ [lb-in]	P_e [HP]	$F_{Ra}^{1)}$ [lb]	F_{Re} [lb]	Stages		ϕ (/R) [']				
						Lg	Sm					
68.09	25	3540	1.5	1330	80	3	-	6	-			
79.72	21	3540	1.3	1330	80	3	-	6	-			
89.29	19	3540	1.1	1330	90	3	-	6	-			
105.09	16	3540	0.95	1330	90	3	-	6	-			
121.57	14	3540	0.82	1330	100	3	-	6	-		F47	AD1
130.07	13	3540	0.77	1330	100	3	-	6	-			
150.06	11	3540	0.67	1330	100	3	-	6	-			
175.38	9.7	3540	0.57	1330	110	3	-	6	-			
190.76	8.9	3540	0.52	1330	110	3	-	6	-			
4.99	341	1530	8.5	700	200	2	-	9	-			
5.76	295	1690	8.2	720	190	2	-	9	-			
6.34	268	1770	7.8	740	190	2	-	8	-			
7.44	228	1990	7.4	760	180	2	-	8	-			
7.88	216	2040	7.2	770	180	2	-	8	-			
8.96	190	2210	6.9	790	170	2	-	8	-			
10.97	155	3360	8.5	720	200	2	-	6	-			
12.66	134	3540	7.8	750	200	2	-	6	-			
13.93	122	3540	7.1	790	210	2	-	6	-			
16.36	104	3540	6.0	870	220	2	-	6	-			
17.33	98	3540	5.7	900	230	2	-	6	-			
19.70	86	3540	5.0	970	230	2	-	6	-			
21.82	78	3540	4.5	1020	240	2	-	6	-			
25.72	66	3540	3.8	1110	240	2	-	6	-			
28.88	59	3540	3.5	1180	310	3	-	7	-			
29.32	58	3540	3.4	1190	250	2	-	6	-		F47	AD2
30.86	55	3540	3.2	1220	250	2	-	6	-			
34.29	50	3540	2.9	1290	320	3	-	7	-			
36.61	46	3540	2.7	1330	320	3	-	7	-			
42.86	40	3540	2.3	1330	330	3	-	7	-			
48.00	35	3540	2.1	1330	330	3	-	7	-			
56.49	30	3540	1.8	1330	330	3	-	7	-			
65.36	26	3540	1.5	1330	230	3	-	7	-			
68.09	25	3540	1.5	1330	330	3	-	6	-			
79.72	21	3540	1.3	1330	340	3	-	6	-			
89.29	19	3540	1.1	1330	340	3	-	6	-			
105.09	16	3540	0.95	1330	350	3	-	6	-			
121.57	14	3540	0.82	1330	360	3	-	6	-			
130.07	13	3540	0.77	1330	360	3	-	6	-			
150.06	11	3540	0.67	1330	360	3	-	6	-			
175.38	9.7	3540	0.57	1330	370	3	-	6	-			
190.76	8.9	3540	0.52	1330	370	3	-	6	-			



Weight [lbs]	Stages		AD1	AD2
	Large	Small		
F47	2	-	41	44
	3	-	42	45

FA47: -2 lb / FAF47: +4 lbs / FF47: +7 lbs

9 F - theSnuggler® Helical

F.. AD

9.2.4 F57

F57 AD.. , $n_e = 1700$ rpm										5310 lb-in		
i [ratio]	n_a [rpm]	$T_{a\ max}$ [lb-in]	P_e [HP]	$F_{Ra}^{1)}$ [lb]	F_{Re} [lb]	Stages		ϕ (/R) [']				
						Lg	Sm					
24.96	68	5090	5.7	1440	160	2	-	6	-			
28.45	60	3630	3.5	1760	240	2	-	6	-			
29.94	57	3670	3.4	1790	240	2	-	6	-			
30.15	56	5220	4.9	1560	270	3	-	7	-			
34.24	50	3890	3.2	1860	230	2	-	6	-			
35.79	47	5310	4.2	1690	280	3	-	7	-			
38.21	44	5310	3.9	1740	280	3	-	7	-			
40.13	42	2350	1.6	2230	100	2	-	6	-			
44.73	38	5310	3.4	1880	290	3	-	7	-			
50.10	34	5310	3.0	1980	290	3	-	7	-			
58.97	29	5310	2.5	2070	300	3	-	7	-		F57	AD2
68.22	25	5310	2.2	2070	300	3	-	6	-			
72.98	23	5310	2.1	2070	300	3	-	6	-			
83.46	20	5310	1.8	2070	340	3	-	6	-			
93.47	18	5310	1.6	2070	270	3	-	6	-			
110.01	15	5310	1.4	2070	280	3	-	6	-			
127.27	13	5310	1.2	2070	290	3	-	6	-			
136.16	12	5310	1.1	2070	290	3	-	6	-			
157.09	11	5310	0.95	2070	300	3	-	6	-			
183.60	9.3	5310	0.82	2070	300	3	-	6	-			
199.70	8.5	5310	0.75	2070	310	3	-	6	-			
5.18	328	2700	14.5	850	270	2	-	9	-			
5.98	284	2960	13.8	870	250	2	-	9	-			
6.58	258	3140	13.3	890	240	2	-	8	-			
7.73	220	3450	12.4	910	210	2	-	8	-			
8.19	208	3540	12.0	930	210	2	-	8	-			
9.31	183	2740	8.2	1130	330	2	-	8	-			
10.64	160	5310	13.9	860	280	2	-	6	-			
12.29	138	5310	12.0	940	300	2	-	6	-			
13.52	126	5310	10.9	1000	310	2	-	6	-			
15.88	107	5310	9.3	1100	330	2	-	6	-			
16.81	101	5310	8.8	1130	340	2	-	6	-			
19.11	89	5310	7.7	1220	350	2	-	6	-		F57	AD3
21.17	80	5310	7.0	1290	360	2	-	6	-			
24.96	68	5090	5.7	1440	380	2	-	6	-			
30.15	56	5220	4.9	1560	480	3	-	7	-			
35.79	47	5310	4.2	1690	490	3	-	7	-			
38.21	44	5310	3.9	1740	500	3	-	7	-			
44.73	38	5310	3.4	1880	500	3	-	7	-			
50.10	34	5310	3.0	1980	510	3	-	7	-			
58.97	29	5310	2.5	2070	510	3	-	7	-			
83.46	20	5310	1.8	2070	550	3	-	6	-			
93.47	18	5310	1.6	2070	560	3	-	6	-			
110.01	15	5310	1.4	2070	560	3	-	6	-			
Weight [lbs]	Stages		AD2		AD3							
	Large	Small										
F57	2	-	59		66							
	3	-	60		67							

FA57: -1 lb / FAF57: +11 lbs / FF57: +14 lbs

9.2.5 F57R37

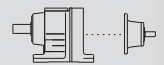
F57R37 AD.. , n _e = 1700 rpm										5310 lb-in		
i [ratio]	n _a [rpm]	T _a max [lb-in]	P _e [HP]	F _{Ra} ¹⁾ [lb]	F _{Re} [lb]	Stages		φ _(/R) [']				
						Lg	Sm					
134	13	5310	1.1	2070	110	2	2	-	-			
152	11	5310	1.0	2070	130	2	2	-	-			
155	11	5310	1.0	2070	120	3	2	-	-			
170	10	5310	0.90	2070	120	2	2	-	-			
181	9.4	5310	0.85	2070	130	3	2	-	-			
200	8.5	5310	0.76	2070	140	2	2	-	-			
201	8.5	5310	0.77	2070	140	3	2	-	-			
226	7.5	5310	0.67	2070	140	2	2	-	-			
255	6.7	5310	0.61	2070	150	3	2	-	-			
262	6.5	5310	0.58	2070	130	2	2	-	-			
298	5.7	5310	0.51	2070	140	2	2	-	-			
330	5.2	5310	0.46	2070	150	2	2	-	-			
338	5.0	5310	0.46	2070	160	3	2	-	-			
382	4.5	5310	0.40	2070	150	2	2	-	-			
386	4.4	5310	0.40	2070	160	3	2	-	-			
426	4.0	5310	0.36	2070	150	2	2	-	-			
452	3.8	5310	0.34	2070	160	3	2	-	-			
483	3.5	5310	0.32	2070	160	2	3	-	-			
506	3.4	5310	0.31	2070	160	3	2	-	-			
549	3.1	5310	0.28	2070	160	2	3	-	-			
558	3.0	5310	0.28	2070	160	3	2	-	-			
646	2.6	5310	0.24	2070	160	3	2	-	-			
658	2.6	5310	0.23	2070	160	2	3	-	-			
738	2.3	5310	0.21	2070	160	3	2	-	-			
749	2.3	5310	0.21	2070	170	2	3	-	-			
851	2.0	5310	0.18	2070	160	3	2	-	-			
856	2.0	5310	0.18	2070	170	2	3	-	-			
949	1.8	5310	0.16	2070	170	2	3	-	-			
967	1.8	5310	0.16	2070	170	3	2	-	-			
1066	1.6	5310	0.14	2070	170	2	3	-	-		F57R37	AD1
1106	1.5	5310	0.14	2070	170	3	2	-	-			
1238	1.4	5310	0.13	2070	170	3	3	-	-			
1243	1.4	5310	0.12	2070	170	2	3	-	-			
1422	1.2	5310	0.11	2070	170	2	3	-	-			
1439	1.2	5310	0.11	2070	170	3	3	-	-			
1617	1.1	5310	0.10	2070	170	2	3	-	-			
1623	1.0	5310	0.10	2070	170	3	3	-	-			
1791	0.95	5310	0.09	2070	170	2	3	-	-			
1840	0.92	5310	0.09	2070	170	3	3	-	-			
2012	0.84	5310	0.08	2070	170	2	3	-	-			
2131	0.80	5310	0.07	2070	170	3	3	-	-			
2266	0.75	5310	0.07	2070	170	2	3	-	-			
2409	0.71	5310	0.07	2070	170	3	3	-	-			
2576	0.66	5310	0.06	2070	170	2	3	-	-			
2737	0.62	5310	0.06	2070	170	3	3	-	-			
2854	0.60	5310	0.05	2070	170	2	3	-	-			
3161	0.54	5310	0.05	2070	170	3	3	-	-			
3564	0.48	5310	0.04	2070	170	3	3	-	-			
4060	0.42	5310	0.04	2070	170	3	3	-	-			
4654	0.37	5310	0.03	2070	170	3	3	-	-			
5289	0.32	5310	0.03	2070	170	3	3	-	-			
6030	0.28	5310	0.03	2070	170	3	3	-	-			
6913	0.25	5310	0.02	2070	170	3	3	-	-			
7908	0.21	5310	0.02	2070	170	3	3	-	-			
8787	0.19	5310	0.02	2070	170	3	3	-	-			
9986	0.17	5310	0.02	2070	170	3	3	-	-			
11252	0.15	5310	0.01	2070	170	3	3	-	-			
12602	0.13	5310	0.01	2070	170	3	3	-	-			
13604	0.12	5310	0.01	2070	170	3	3	-	-			
14832	0.11	5310	0.01	2070	170	3	3	-	-			

9 F - theSnuggler® Helical

F.. AD

F57R37 AD.. , $n_e = 1700$ rpm

5310 lb-in

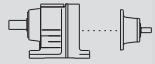

i [ratio]	n_a [rpm]	T_a max [lb-in]	P_e [HP]	$F_{Ra}^{1)}$ [lb]	F_{Re} [lb]	Stages		ϕ (°/R) [']		
						Lg	Sm			
134	13	5310	1.1	2070	370	2	2	-	-	
152	11	5310	1.0	2070	370	2	2	-	-	
155	11	5310	1.0	2070	370	3	2	-	-	
170	10	5310	0.90	2070	370	2	2	-	-	
181	9.4	5310	0.85	2070	380	3	2	-	-	
200	8.5	5310	0.76	2070	380	2	2	-	-	
201	8.5	5310	0.77	2070	380	3	2	-	-	
226	7.5	5310	0.67	2070	380	2	2	-	-	
255	6.7	5310	0.61	2070	380	3	2	-	-	
262	6.5	5310	0.58	2070	380	2	2	-	-	
298	5.7	5310	0.51	2070	380	2	2	-	-	
330	5.2	5310	0.46	2070	380	2	2	-	-	
338	5.0	5310	0.46	2070	390	3	2	-	-	
382	4.5	5310	0.40	2070	380	2	2	-	-	
386	4.4	5310	0.40	2070	390	3	2	-	-	
426	4.0	5310	0.36	2070	380	2	2	-	-	
452	3.8	5310	0.34	2070	390	3	2	-	-	
483	3.5	5310	0.32	2070	390	2	3	-	-	
506	3.4	5310	0.31	2070	390	3	2	-	-	
549	3.1	5310	0.28	2070	390	2	3	-	-	
558	3.0	5310	0.28	2070	390	3	2	-	-	
646	2.6	5310	0.24	2070	390	3	2	-	-	
658	2.6	5310	0.23	2070	390	2	3	-	-	
738	2.3	5310	0.21	2070	390	3	2	-	-	
749	2.3	5310	0.21	2070	390	2	3	-	-	
851	2.0	5310	0.18	2070	390	3	2	-	-	
856	2.0	5310	0.18	2070	390	2	3	-	-	
949	1.8	5310	0.16	2070	390	2	3	-	-	
967	1.8	5310	0.16	2070	390	3	2	-	-	
1066	1.6	5310	0.14	2070	390	2	3	-	-	F57R37
1106	1.5	5310	0.14	2070	400	3	2	-	-	AD2
1238	1.4	5310	0.13	2070	400	3	3	-	-	
1243	1.4	5310	0.12	2070	400	2	3	-	-	
1422	1.2	5310	0.11	2070	400	2	3	-	-	
1439	1.2	5310	0.11	2070	400	3	3	-	-	
1617	1.1	5310	0.10	2070	400	2	3	-	-	
1623	1.0	5310	0.10	2070	400	3	3	-	-	
1791	0.95	5310	0.09	2070	400	2	3	-	-	
1840	0.92	5310	0.09	2070	400	3	3	-	-	
2012	0.84	5310	0.08	2070	400	2	3	-	-	
2131	0.80	5310	0.07	2070	400	3	3	-	-	
2266	0.75	5310	0.07	2070	400	2	3	-	-	
2409	0.71	5310	0.07	2070	400	3	3	-	-	
2576	0.66	5310	0.06	2070	400	2	3	-	-	
2737	0.62	5310	0.06	2070	400	3	3	-	-	
2854	0.60	5310	0.05	2070	400	2	3	-	-	
3161	0.54	5310	0.05	2070	400	3	3	-	-	
3564	0.48	5310	0.04	2070	400	3	3	-	-	
4060	0.42	5310	0.04	2070	400	3	3	-	-	
4654	0.37	5310	0.03	2070	400	3	3	-	-	
5289	0.32	5310	0.03	2070	400	3	3	-	-	
6030	0.28	5310	0.03	2070	400	3	3	-	-	
6913	0.25	5310	0.02	2070	400	3	3	-	-	
7908	0.21	5310	0.02	2070	400	3	3	-	-	
8787	0.19	5310	0.02	2070	400	3	3	-	-	
9986	0.17	5310	0.02	2070	400	3	3	-	-	
11252	0.15	5310	0.01	2070	400	3	3	-	-	
12602	0.13	5310	0.01	2070	400	3	3	-	-	
13604	0.12	5310	0.01	2070	400	3	3	-	-	
14832	0.11	5310	0.01	2070	400	3	3	-	-	

Weight [lbs]	Stages		AD1	AD2
	Large	Small		
F57R37	2	2	80	83
	2	3	81	83
	3	2	82	84
	3	3	82	85
FA57: -1 lb / FAF57: +11 lbs / FF57: +14 lbs				

9 F - theSnuggler® Helical

F.. AD



9.2.6 F67

F67 AD.. , n _e = 1700 rpm										7260 lb-in	
i [ratio]	n _a [rpm]	T _{a max} [lb-in]	P _e [HP]	F _{Ra} ¹⁾ [lb]	F _{Re} [lb]	Stages		φ (°/R) [']			
						Lg	Sm			F67	AD2
32.08	53	6810	5.9	2410	140	2	-	5	-		
34.01	50	6550	5.4	2470	270	3	-	6	-		
36.30	47	5220	4.0	2690	220	2	-	5	-		
39.26	43	6900	5.0	2400	280	3	-	6	-		
43.20	39	7260	4.7	2320	270	3	-	6	-		
50.74	34	7260	4.0	2320	280	3	-	6	-		
53.73	32	7260	3.8	2320	290	3	-	6	-		
61.07	28	7260	3.4	2320	290	3	-	6	-		
67.65	25	7260	3.0	2320	290	3	-	6	-		
79.76	21	7260	2.6	2320	300	3	-	6	-	F67	AD2
90.59	19	7260	2.3	2320	330	3	-	6	-		
95.94	18	7260	2.1	2320	340	3	-	6	-		
109.04	16	7260	1.9	2320	340	3	-	6	-		
120.79	14	7260	1.7	2320	340	3	-	6	-		
142.40	12	7260	1.4	2320	260	3	-	6	-		
162.31	10	7260	1.3	2320	270	3	-	6	-		
170.85	10	7260	1.2	2320	270	3	-	6	-		
195.39	8.7	7260	1.0	2320	280	3	-	6	-		
228.99	7.4	7260	0.89	2320	280	3	-	6	-		
3.97	428	2430	17.0	2030	290	2	-	10	M1-6		
4.66	365	2700	16.1	2110	290	2	-	9	M2		
5.25	324	2920	15.5	2170	280	2	-	9	-		
5.95	286	3140	14.7	2240	270	2	-	9	-		
6.78	251	3410	14.0	2310	250	2	-	9	-		
7.53	226	3630	13.4	2360	230	2	-	8	-		
8.60	198	3890	12.6	2440	210	2	-	8	-		
9.08	187	3980	12.2	2480	200	2	-	8	-		
9.66	176	5930	17.1	2400	290	2	-	6	M1-6		
11.31	150	6590	16.2	2460	280	2	-	6	M2		
12.76	133	7080	15.4	2360	280	2	-	6	-		
14.46	118	7260	14.0	2320	290	2	-	6	-		
16.48	103	7260	12.2	2320	300	2	-	6	-		
18.29	93	7260	11.0	2320	320	2	-	6	-		
20.90	81	7260	9.7	2320	330	2	-	5	-		
22.05	77	7260	9.2	2320	330	2	-	5	-	F67	AD3
25.13	68	7260	8.0	2320	340	2	-	5	-		
27.41	62	7260	7.4	2320	350	2	-	5	-		
32.08	53	7260	6.3	2320	360	2	-	5	-		
34.01	50	6550	5.4	2470	490	3	-	6	-		
39.26	43	6900	5.0	2400	490	3	-	6	-		
43.20	39	7260	4.7	2320	490	3	-	6	-		
50.74	34	7260	4.0	2320	500	3	-	6	-		
53.73	32	7260	3.8	2320	500	3	-	6	-		
61.07	28	7260	3.4	2320	500	3	-	6	-		
67.65	25	7260	3.0	2320	510	3	-	6	-		
79.76	21	7260	2.6	2320	510	3	-	6	-		
90.59	19	7260	2.3	2320	550	3	-	6	-		
95.94	18	7260	2.1	2320	550	3	-	6	-		
109.04	16	7260	1.9	2320	550	3	-	6	-		
120.79	14	7260	1.7	2320	550	3	-	6	-		
142.40	12	7260	1.4	2320	560	3	-	6	-		

Weight [lbs]	Stages		AD2	AD3
	Large	Small		
F67	2	-	72	79
	3	-	75	82

FA67: -6 lb / FAF67: +8 lbs / FF67: +13 lbs

9.2.7 F67R37

F67R37 AD.. , n _e = 1700 rpm										7260 lb-in	
i [ratio]	n _a [rpm]	T _a max [lb-in]	P _e [HP]	F _{Ra} ¹⁾ [lb]	F _{Re} [lb]	Stages		φ (/R) [']			
						Lg	Sm				
175	9.7	7260	1.2	2320	100	3	2	-	-		
176	9.7	7260	1.2	2320	110	2	2	-	-		
200	8.5	7260	1.0	2320	120	2	2	-	-		
205	8.3	7260	1.0	2320	110	3	2	-	-		
231	7.4	7260	0.91	2320	130	3	2	-	-		
238	7.1	7260	0.87	2320	130	2	2	-	-		
257	6.6	7260	0.82	2320	120	3	2	-	-		
261	6.5	7260	0.80	2320	120	2	2	-	-		
297	5.7	7260	0.70	2320	140	2	2	-	-		
305	5.6	7260	0.69	2320	130	3	2	-	-		
333	5.1	7260	0.62	2320	140	2	2	-	-		
338	5.0	7260	0.62	2320	130	3	2	-	-		
384	4.4	7260	0.55	2320	150	3	2	-	-		
392	4.3	7260	0.53	2320	140	2	2	-	-		
437	3.9	7260	0.48	2320	160	3	2	-	-		
454	3.7	7260	0.46	2320	140	2	2	-	-		
500	3.4	7260	0.42	2320	150	2	2	-	-		
509	3.3	7260	0.41	2320	160	3	2	-	-		
539	3.2	7260	0.39	2320	160	2	3	-	-		
572	3.0	7260	0.37	2320	160	3	2	-	-		
634	2.7	7260	0.33	2320	160	2	3	-	-		
641	2.7	7260	0.33	2320	160	3	2	-	-		
722	2.4	7260	0.29	2320	160	2	3	-	-		
755	2.3	7260	0.28	2320	160	3	2	-	-		
858	2.0	7260	0.25	2320	170	3	2	-	-		
864	2.0	7260	0.24	2320	160	2	3	-	-		
970	1.8	7260	0.22	2320	170	3	2	-	-		
984	1.7	7260	0.21	2320	160	2	3	-	-		
1102	1.5	7260	0.19	2320	170	3	2	-	-		
1126	1.5	7260	0.19	2320	170	2	3	-	-		
1256	1.4	7260	0.17	2320	170	2	3	-	-	F67R37	AD1
1271	1.3	7260	0.17	2320	170	3	2	-	-		
1429	1.2	7260	0.15	2320	170	3	2	-	-		
1437	1.2	7260	0.15	2320	170	2	3	-	-		
1631	1.0	7260	0.13	2320	170	2	3	-	-		
1635	1.0	7260	0.13	2320	170	3	2	-	-		
1859	0.91	7260	0.11	2320	170	2	3	-	-		
1884	0.90	7260	0.11	2320	170	3	2	-	-		
2106	0.81	7260	0.10	2320	170	3	2	-	-		
2126	0.80	7260	0.10	2320	170	2	3	-	-		
2372	0.72	7260	0.09	2320	170	2	3	-	-		
2439	0.70	7260	0.09	2320	170	3	3	-	-		
2714	0.63	7260	0.08	2320	170	2	3	-	-		
2756	0.62	7260	0.08	2320	170	3	3	-	-		
2912	0.58	7260	0.07	2320	170	2	3	-	-		
3133	0.54	7260	0.07	2320	170	3	3	-	-		
3377	0.50	7260	0.06	2320	170	2	3	-	-		
3574	0.48	7260	0.06	2320	170	3	3	-	-		
4091	0.42	7260	0.05	2320	170	3	3	-	-		
4690	0.36	7260	0.05	2320	170	3	3	-	-		
5341	0.32	7260	0.04	2320	170	3	3	-	-		
6080	0.28	7260	0.04	2320	170	3	3	-	-		
7096	0.24	7260	0.03	2320	170	3	3	-	-		
7940	0.21	7260	0.03	2320	170	3	3	-	-		
8933	0.19	7260	0.02	2320	170	3	3	-	-		
10220	0.17	7260	0.02	2320	170	3	3	-	-		
11480	0.15	7260	0.02	2320	170	3	3	-	-		
12926	0.13	7260	0.02	2320	170	3	3	-	-		
14992	0.11	7260	0.01	2320	170	3	3	-	-		
17610	0.10	7260	0.01	2320	170	3	3	-	-		
19199	0.09	7260	0.01	2320	170	3	3	-	-		

9 F - theSnuggler® Helical

F.. AD

F67R37 AD.. , n_e = 1700 rpm

7260 lb-in

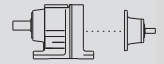

i [ratio]	n _a [rpm]	T _a max [lb-in]	P _e [HP]	F _{Ra} ¹⁾ [lb]	F _{Re} [lb]	Stages		φ _(/R) [']		
						Lg	Sm			
176	9.7	7260	1.2	2320	370	2	2	-	-	
200	8.5	7260	1.0	2320	370	2	2	-	-	
205	8.3	7260	1.0	2320	370	3	2	-	-	
231	7.4	7260	0.91	2320	380	3	2	-	-	
238	7.1	7260	0.87	2320	370	2	2	-	-	
257	6.6	7260	0.82	2320	370	3	2	-	-	
261	6.5	7260	0.80	2320	370	2	2	-	-	
297	5.7	7260	0.70	2320	380	2	2	-	-	
305	5.6	7260	0.69	2320	380	3	2	-	-	
333	5.1	7260	0.62	2320	380	2	2	-	-	
338	5.0	7260	0.62	2320	380	3	2	-	-	
384	4.4	7260	0.55	2320	380	3	2	-	-	
392	4.3	7260	0.53	2320	380	2	2	-	-	
437	3.9	7260	0.48	2320	390	3	2	-	-	
454	3.7	7260	0.46	2320	380	2	2	-	-	
500	3.4	7260	0.42	2320	380	2	2	-	-	
509	3.3	7260	0.41	2320	390	3	2	-	-	
539	3.2	7260	0.39	2320	390	2	3	-	-	
572	3.0	7260	0.37	2320	390	3	2	-	-	
634	2.7	7260	0.33	2320	390	2	3	-	-	
641	2.7	7260	0.33	2320	390	3	2	-	-	
722	2.4	7260	0.29	2320	390	2	3	-	-	
755	2.3	7260	0.28	2320	390	3	2	-	-	
858	2.0	7260	0.25	2320	390	3	2	-	-	
864	2.0	7260	0.24	2320	390	2	3	-	-	
970	1.8	7260	0.22	2320	390	3	2	-	-	
984	1.7	7260	0.21	2320	390	2	3	-	-	
1102	1.5	7260	0.19	2320	400	3	2	-	-	
1126	1.5	7260	0.19	2320	390	2	3	-	-	
1256	1.4	7260	0.17	2320	390	2	3	-	-	
1271	1.3	7260	0.17	2320	400	3	2	-	-	
1429	1.2	7260	0.15	2320	400	3	2	-	-	
1437	1.2	7260	0.15	2320	390	2	3	-	-	
1631	1.0	7260	0.13	2320	400	2	3	-	-	
1635	1.0	7260	0.13	2320	400	3	2	-	-	
1859	0.91	7260	0.11	2320	400	2	3	-	-	
1884	0.90	7260	0.11	2320	400	3	2	-	-	
2106	0.81	7260	0.10	2320	400	3	2	-	-	
2126	0.80	7260	0.10	2320	400	2	3	-	-	
2372	0.72	7260	0.09	2320	400	2	3	-	-	
2439	0.70	7260	0.09	2320	400	3	3	-	-	
2714	0.63	7260	0.08	2320	400	2	3	-	-	
2756	0.62	7260	0.08	2320	400	3	3	-	-	
2912	0.58	7260	0.07	2320	400	2	3	-	-	
3133	0.54	7260	0.07	2320	400	3	3	-	-	
3377	0.50	7260	0.06	2320	400	2	3	-	-	
3574	0.48	7260	0.06	2320	400	3	3	-	-	
4091	0.42	7260	0.05	2320	400	3	3	-	-	
4690	0.36	7260	0.05	2320	400	3	3	-	-	
5341	0.32	7260	0.04	2320	400	3	3	-	-	
6080	0.28	7260	0.04	2320	400	3	3	-	-	
7096	0.24	7260	0.03	2320	400	3	3	-	-	
7940	0.21	7260	0.03	2320	400	3	3	-	-	
8933	0.19	7260	0.02	2320	400	3	3	-	-	
10220	0.17	7260	0.02	2320	400	3	3	-	-	
11480	0.15	7260	0.02	2320	400	3	3	-	-	
12926	0.13	7260	0.02	2320	400	3	3	-	-	
14992	0.11	7260	0.01	2320	400	3	3	-	-	
17610	0.10	7260	0.01	2320	400	3	3	-	-	
19199	0.09	7260	0.01	2320	400	3	3	-	-	

F67R37



AD2

Weight [lbs]	Stages		AD1	AD2
	Large	Small		
F67R37	2	2	93	96
	2	3	94	96
	3	2	96	98
	3	3	96	99
FA67: -6 lb / FAF67: +8 lbs / FF67: +13 lbs				

9.2.8 F77

F77 AD.. , n _e = 1700 rpm										13280 lb-in		
i [ratio]	n _a [rpm]	T _{a max} [lb-in]	P _e [HP]	F _{Ra} ¹⁾ [lb]	F _{Re} [lb]	Stages		φ (/R) [']			F77	AD2
						Lg	Sm					
48.37	35	13280	7.7	3540	200	3	-	6	-			
55.27	31	13280	6.8	3540	210	3	-	6	-			
58.32	29	13280	6.4	3540	210	3	-	6	-			
66.46	26	13280	5.6	3540	220	3	-	6	-			
72.50	23	13280	5.2	3540	220	3	-	6	-			
75.02	23	13280	5.0	3540	290	3	-	6	-			
85.52	20	13280	4.4	3540	290	3	-	6	-			
94.93	18	13280	3.9	3540	300	3	-	5	-			
108.46	16	13280	3.5	3540	300	3	-	5	-			
114.45	15	13280	3.3	3540	310	3	-	5	-			
130.42	13	13280	2.9	3540	310	3	-	5	-			
142.27	12	13280	2.6	3540	310	3	-	5	-			
166.47	10	13280	2.3	3540	310	3	-	5	-			
188.40	9	13280	2.0	3540	320	3	-	5	-			
198.31	8.6	13280	1.9	3540	320	3	-	5	-			
225.79	7.5	13280	1.7	3540	320	3	-	5	-			
262.93	6.5	13280	1.4	3540	160	3	-	5	-			
281.71	6.0	13280	1.3	3540	160	3	-	5	-			
4.28	397	2880	18.7	2820	320	2	-	8	M2			
5.16	329	3270	17.6	2960	310	2	-	8	-			
5.76	295	3540	17.1	3040	300	2	-	8	-			
6.64	256	3850	16.1	3150	290	2	-	8	-			
7.39	230	4120	15.5	3240	280	2	-	7	-			
8.26	206	4380	14.7	3330	270	2	-	7	-			
9.30	183	4690	14.0	3430	250	2	-	7	-			
10.93	156	6990	17.8	3540	300	2	-	6	-			
12.20	139	7520	17.1	3630	290	2	-	5	-			
14.06	121	8140	16.1	3760	290	2	-	5	-			
15.64	109	8760	15.6	3850	280	2	-	5	-			
17.49	97	9290	14.8	3960	270	2	-	5	-			
19.70	86	9910	14.0	4000	250	2	-	5	-			
21.43	79	10440	13.5	3940	230	2	-	5	-			
25.50	67	11150	12.2	3850	210	2	-	5	-			
25.54	67	12830	14.2	3610	370	3	-	6	-			
28.75	59	10620	10.3	3920	260	2	-	5	-			
29.91	57	13280	12.5	3540	380	3	-	6	-			
31.51	54	9820	8.7	4010	310	2	-	5	-			
33.74	50	13280	11.1	3540	390	3	-	6	-			
36.58	46	9820	7.5	4010	310	2	-	5	-			
38.23	44	13280	9.8	3540	400	3	-	6	-			
43.58	39	13280	8.6	3540	410	3	-	6	-			
48.37	35	13280	7.7	3540	420	3	-	6	-			
55.27	31	13280	6.8	3540	430	3	-	6	-			
58.32	29	13280	6.4	3540	430	3	-	6	-			
66.46	26	13280	5.6	3540	440	3	-	6	-			
72.50	23	13280	5.2	3540	440	3	-	6	-			
75.02	23	13280	5.0	3540	500	3	-	6	-			
85.52	20	13280	4.4	3540	510	3	-	6	-			
94.93	18	13280	3.9	3540	510	3	-	5	-			
108.46	16	13280	3.5	3540	520	3	-	5	-			
114.45	15	13280	3.3	3540	520	3	-	5	-			
130.42	13	13280	2.9	3540	520	3	-	5	-			
142.27	12	13280	2.6	3540	520	3	-	5	-			
166.47	10	13280	2.3	3540	530	3	-	5	-			



F77 AD.. , n_e = 1700 rpm **13280 lb-in**

i [ratio]	n _a [rpm]	T _{a max} [lb-in]	P _e [HP]	F _{Ra} ¹⁾ [lb]	F _{Re} [lb]	Stages		φ _(/R) [']		
						Lg	Sm			
4.28	397	6990	45	2330	230	2	-	8	M1-6	F77 AD4
5.16	329	8320	45	2360	110	2	-	8	M1-6	
5.76	295	9380	45	2340	0	2	-	8	M1-6	
6.64	256	9560	40	2470	40	2	-	8	M1-6	
7.39	230	9560	36	2590	80	2	-	7	M1-6	
8.26	206	9560	32	2720	130	2	-	7	M1-6	
9.30	183	9560	29	2860	170	2	-	7	M1-6	
10.93	156	13280	34	2950	460	2	-	6	M1-6	
12.20	139	13280	30	3090	510	2	-	5	M1-6	
14.06	121	13280	26	3280	540	2	-	5	M1-6	
15.64	109	13280	24	3430	550	2	-	5	M2	
17.49	97	13280	21	3540	570	2	-	5	-	
19.70	86	13280	18.7	3540	580	2	-	5	-	
21.43	79	13280	17.2	3540	600	2	-	5	-	
25.50	67	13280	14.5	3540	610	2	-	5	-	
25.54	67	12830	14.2	3610	780	3	-	6	M2	
29.91	57	13280	12.5	3540	780	3	-	6	-	
33.74	50	13280	11.1	3540	790	3	-	6	-	
38.23	44	13280	9.8	3540	800	3	-	6	-	
43.58	39	13280	8.6	3540	810	3	-	6	-	
48.37	35	13280	7.7	3540	820	3	-	6	-	
55.27	31	13280	6.8	3540	830	3	-	6	-	
58.32	29	13280	6.4	3540	830	3	-	6	-	
75.02	23	13280	5.0	3540	890	3	-	6	-	
85.52	20	13280	4.4	3540	900	3	-	6	-	
94.93	18	13280	3.9	3540	900	3	-	5	-	
108.46	16	13280	3.5	3540	910	3	-	5	-	
114.45	15	13280	3.3	3540	910	3	-	5	-	

Weight [lbs]	Stages		AD2	AD3	AD4
	Large	Small			
F77	2	-	124	132	145
	3	-	127	135	148

FA77: -9 lb / FAF77: +6 lbs / FF77: +23 lbs



9.2.9 F77R37

F77R37 AD.. , n _e = 1700 rpm										13280 lb-in		
i [ratio]	n _a [rpm]	T _{a max} [lb-in]	P _e [HP]	F _{Ra} ¹⁾ [lb]	F _{Re} [lb]	Stages		φ _(/R) [']				
						Lg	Sm					
292	5.8	9820	0.96	4010	130	2	2	-	-			
323	5.3	12390	1.1	3680	70	3	2	-	-			
346	4.9	9820	0.81	4010	130	2	2	-	-			
367	4.6	13280	1.1	3540	100	3	2	-	-			
413	4.1	13280	0.94	3540	120	3	2	-	-			
433	3.9	9820	0.65	4010	140	2	2	-	-			
480	3.5	13280	0.80	3540	120	3	2	-	-			
538	3.2	13280	0.72	3540	130	3	2	-	-			
571	3.0	9820	0.49	4010	150	2	2	-	-			
615	2.8	13280	0.63	3540	140	3	2	-	-			
660	2.6	9820	0.43	4010	150	2	2	-	-			
710	2.4	13280	0.54	3540	160	3	2	-	-			
810	2.1	13280	0.48	3540	160	3	2	-	-			
893	1.9	9820	0.32	4010	160	2	3	-	-			
910	1.9	13280	0.42	3540	150	3	2	-	-			
1053	1.6	13280	0.37	3540	160	3	2	-	-			
1200	1.4	13280	0.32	3540	160	3	2	-	-			
1354	1.3	13280	0.29	3540	160	3	2	-	-			
1433	1.2	9820	0.20	4010	170	2	3	-	-			
1544	1.1	13280	0.25	3540	160	3	2	-	-			
1639	1.0	9820	0.17	4010	170	2	3	-	-			
1728	0.98	13280	0.22	3540	170	3	2	-	-			
1759	0.97	9820	0.16	4010	170	2	3	-	-			
2029	0.84	13280	0.19	3540	170	3	3	-	-			
2238	0.76	9820	0.13	4010	170	2	3	-	-			
2284	0.74	13280	0.17	3540	170	3	3	-	-			
2536	0.67	9820	0.11	4010	170	2	3	-	-			
2613	0.65	13280	0.15	3540	170	3	3	-	-			
2705	0.63	9820	0.11	4010	170	2	3	-	-			
2978	0.57	13280	0.13	3540	170	3	3	-	-			
3095	0.55	9820	0.09	4010	170	2	3	-	-			
3320	0.51	9820	0.09	4010	170	2	3	-	-			
3381	0.50	13280	0.12	3540	170	3	3	-	-			
3832	0.44	13280	0.10	3540	170	3	3	-	-			
4435	0.38	13280	0.09	3540	170	3	3	-	-			
4523	0.38	9820	0.06	4010	170	2	3	-	-			
4931	0.34	9820	0.06	4010	170	2	3	-	-			
5026	0.34	13280	0.08	3540	170	3	3	-	-			
5808	0.29	13280	0.07	3540	170	3	3	-	-			
6580	0.26	13280	0.06	3540	170	3	3	-	-			
7520	0.23	13280	0.05	3540	170	3	3	-	-			
8464	0.20	13280	0.05	3540	170	3	3	-	-			
9683	0.18	13280	0.04	3540	170	3	3	-	-			
11035	0.15	13280	0.04	3540	170	3	3	-	-			
12049	0.14	13280	0.03	3540	170	3	3	-	-			
13731	0.12	13280	0.03	3540	170	3	3	-	-			
14978	0.11	13280	0.03	3540	170	3	3	-	-			
16128	0.11	13280	0.02	3540	170	3	3	-	-			
17593	0.10	13280	0.02	3540	170	3	3	-	-			
19180	0.09	13280	0.02	3540	170	3	3	-	-			
199	8.5	13280	1.9	3540	350	3	2	-	-			
221	7.7	13280	1.7	3540	340	3	2	-	-			
247	6.9	13280	1.6	3540	270	3	2	-	-			
280	6.1	13280	1.4	3540	310	3	2	-	-			
292	5.8	9820	0.96	4010	370	2	2	-	-			
323	5.3	13280	1.2	3540	300	3	2	-	-			
346	4.9	9820	0.81	4010	380	2	2	-	-			
367	4.6	13280	1.1	3540	360	3	2	-	-			

F77R37 AD1

F77R37 AD2

F77R37 AD.. , n_e = 1700 rpm **13280 lb-in**

i [ratio]	n _a [rpm]	T _a max [lb-in]	P _e [HP]	F _{Ra} ¹⁾ [lb]	F _{Re} [lb]	Stages		φ ^(/R) [']		
						Lg	Sm			
413	4.1	13280	0.94	3540	370	3	2	-	-	
433	3.9	9820	0.65	4010	380	2	2	-	-	
480	3.5	13280	0.80	3540	370	3	2	-	-	
538	3.2	13280	0.72	3540	370	3	2	-	-	
571	3.0	9820	0.49	4010	380	2	2	-	-	
615	2.8	13280	0.63	3540	380	3	2	-	-	
660	2.6	9820	0.43	4010	380	2	2	-	-	
710	2.4	13280	0.54	3540	380	3	2	-	-	
810	2.1	13280	0.48	3540	390	3	2	-	-	
815	2.1	9820	0.35	4010	380	2	2	-	-	
893	1.9	9820	0.32	4010	390	2	3	-	-	
910	1.9	13280	0.42	3540	380	3	2	-	-	
1053	1.6	13280	0.37	3540	380	3	2	-	-	
1200	1.4	13280	0.32	3540	390	3	2	-	-	
1354	1.3	13280	0.29	3540	390	3	2	-	-	
1433	1.2	9820	0.20	4010	390	2	3	-	-	
1544	1.1	13280	0.25	3540	390	3	2	-	-	
1639	1.0	9820	0.17	4010	390	2	3	-	-	
1728	0.98	13280	0.22	3540	390	3	2	-	-	
1759	0.97	9820	0.16	4010	390	2	3	-	-	
2029	0.84	13280	0.19	3540	390	3	3	-	-	
2238	0.76	9820	0.13	4010	400	2	3	-	-	
2284	0.74	13280	0.17	3540	390	3	3	-	-	
2536	0.67	9820	0.11	4010	400	2	3	-	-	F77R37
2613	0.65	13280	0.15	3540	390	3	3	-	-	AD2
2705	0.63	9820	0.11	4010	400	2	3	-	-	
2978	0.57	13280	0.13	3540	400	3	3	-	-	
3095	0.55	9820	0.09	4010	400	2	3	-	-	
3320	0.51	9820	0.09	4010	400	2	3	-	-	
3381	0.50	13280	0.12	3540	400	3	3	-	-	
3832	0.44	13280	0.10	3540	400	3	3	-	-	
4435	0.38	13280	0.09	3540	400	3	3	-	-	
4523	0.38	9820	0.06	4010	400	2	3	-	-	
4931	0.34	9820	0.06	4010	400	2	3	-	-	
5026	0.34	13280	0.08	3540	400	3	3	-	-	
5808	0.29	13280	0.07	3540	400	3	3	-	-	
6580	0.26	13280	0.06	3540	400	3	3	-	-	
7520	0.23	13280	0.05	3540	400	3	3	-	-	
8464	0.20	13280	0.05	3540	400	3	3	-	-	
9683	0.18	13280	0.04	3540	400	3	3	-	-	
11035	0.15	13280	0.04	3540	400	3	3	-	-	
12049	0.14	13280	0.03	3540	400	3	3	-	-	
13731	0.12	13280	0.03	3540	400	3	3	-	-	
14978	0.11	13280	0.03	3540	400	3	3	-	-	
16128	0.11	13280	0.02	3540	400	3	3	-	-	
17593	0.10	13280	0.02	3540	400	3	3	-	-	
19180	0.09	13280	0.02	3540	400	3	3	-	-	



Weight [lbs]	Stages		AD1	AD2
	Large	Small		
F77R37	2	2	144	147
	2	3	145	147
	3	2	147	150
	3	3	148	150

FA77: -9 lb / FAF77: +6 lbs / FF77: +23 lbs



9 F - theSnuggler® Helical

F.. AD

9.2.10 F87

F87 AD.. , $n_e = 1700$ rpm										26550 lb-in	
i [ratio]	n_a [rpm]	$T_{a \max}$ [lb-in]	P_e [HP]	$F_{Ra}^{1)}$ [lb]	F_{Re} [lb]	Stages		ϕ (°/R) [']			
						Lg	Sm				
76.39	22	26550	9.8	4200	220	3	-	7	-		
88.01	19	26550	8.5	4450	230	3	-	7	-		
97.89	17	26550	7.7	4450	240	3	-	7	-		
109.49	16	26550	6.8	4450	250	3	-	7	-		
123.29	14	26550	6.1	4450	250	3	-	7	-		
134.16	13	26550	5.6	4450	260	3	-	7	-		
159.61	11	26550	4.7	4450	260	3	-	7	-		
179.97	9.4	26550	4.2	4450	270	3	-	7	-		
197.20	8.6	26550	3.8	4450	270	3	-	7	-		
228.93	7.4	26550	3.3	4450	270	3	-	7	-		
255.37	6.7	26550	2.9	4450	280	3	-	7	-		
270.68	6.3	26550	2.8	4450	280	3	-	7	-		
39.30	43	24070	17.3	3090	300	3	-	8	-		
45.28	38	24960	15.6	3270	310	3	-	8	-		
50.36	34	26020	14.6	3370	310	3	-	7	-		
56.75	30	26550	13.2	3560	400	3	-	7	-		
68.40	25	26550	11.0	3960	410	3	-	7	-		
76.39	22	26550	9.8	4200	420	3	-	7	-		
88.01	19	26550	8.5	4450	430	3	-	7	-		
97.89	17	26550	7.7	4450	440	3	-	7	-		
109.49	16	26550	6.8	4450	440	3	-	7	-		
123.29	14	26550	6.1	4450	450	3	-	7	-		
134.16	13	26550	5.6	4450	450	3	-	7	-		
159.61	11	26550	4.7	4450	460	3	-	7	-		
179.97	9.4	26550	4.2	4450	460	3	-	7	-		
197.20	8.6	26550	3.8	4450	460	3	-	7	-		
228.93	7.4	26550	3.3	4450	470	3	-	7	-		
23.68	72	23280	27	2320	340	2	-	7	-		
26.50	64	24340	26	2400	310	2	-	7	-		
28.78	59	21150	20	2840	510	2	-	7	-		
29.20	58	22210	21	2760	710	3	-	8	M2,5-6		
33.92	50	22660	18.6	2970	460	2	-	7	-		
35.19	48	23100	18.5	2990	730	3	-	8	-		
39.30	43	24070	17.3	3090	730	3	-	8	-		
45.28	38	24960	15.6	3270	730	3	-	8	-		
50.36	34	26020	14.6	3370	730	3	-	7	-		
56.75	30	26550	13.2	3560	820	3	-	7	-		
68.40	25	26550	11.0	3960	830	3	-	7	-		
76.39	22	26550	9.8	4200	840	3	-	7	-		
88.01	19	26550	8.5	4450	850	3	-	7	-		
97.89	17	26550	7.7	4450	850	3	-	7	-		
109.49	16	26550	6.8	4450	860	3	-	7	-		
123.29	14	26550	6.1	4450	860	3	-	7	-		
134.16	13	26550	5.6	4450	870	3	-	7	-		
159.61	11	26550	4.7	4450	870	3	-	7	-		

F87 AD.. , n_e = 1700 rpm **26550 lb-in**

i [ratio]	n _a [rpm]	T _{a max} [lb-in]	P _e [HP]	F _{Ra} ¹⁾ [lb]	F _{Re} [lb]	Stages		φ _(/R) [']		
						Lg	Sm			
4.12	413	11150	75	1360	840	2	-	7	M1-6	F87 AD5
4.92	346	13360	75	1280	650	2	-	7	M1-6	
5.63	302	13540	67	1390	700	2	-	7	M1-6	
6.65	256	13540	57	1550	820	2	-	7	M1-6	
7.35	231	13540	51	1650	870	2	-	7	M1-6	
8.29	205	13540	45	1780	890	2	-	7	M1-6	
9.58	177	25490	74	910	850	2	-	7	M1-6	
11.46	148	26550	64	1010	880	2	-	7	M1-6	
13.12	130	26550	56	1180	920	2	-	7	M1-6	
15.48	110	26550	48	1390	970	2	-	7	M1-6	
17.12	99	26550	43	1530	990	2	-	7	M1-6	
19.31	88	26550	38	1700	1010	2	-	7	M1-6	
21.32	80	26550	35	1840	1030	2	-	7	-	
23.68	72	26550	31	2000	1040	2	-	7	-	
26.50	64	26550	28	2180	1060	2	-	7	-	
29.20	58	22210	21	2760	1380	3	-	8	M2,5-6	
35.19	48	23100	18.5	2990	1400	3	-	8	-	
39.30	43	24070	17.3	3090	1400	3	-	8	-	
45.28	38	24960	15.6	3270	1400	3	-	8	-	
50.36	34	26020	14.6	3370	1400	3	-	7	-	
56.75	30	26550	13.2	3560	1490	3	-	7	-	
68.40	25	26550	11.0	3960	1500	3	-	7	-	
76.39	22	26550	9.8	4200	1510	3	-	7	-	
88.01	19	26550	8.5	4450	1510	3	-	7	-	
97.89	17	26550	7.7	4450	1520	3	-	7	-	
109.49	16	26550	6.8	4450	1520	3	-	7	-	
123.29	14	26550	6.1	4450	1530	3	-	7	-	



Weight [lbs]	Stages		AD2	AD3	AD3	AD4
	Large	Small				
F87	2	-	211	220	234	267
	3	-	218	227	240	273

FA87: -13 lb / FAF87: +15 lbs / FF87: +34 lbs

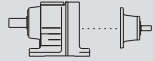
9.2.11 F87R57

F87R57 AD.. , n _e = 1700 rpm										26550 lb-in		
i [ratio]	n _a [rpm]	T _a max [lb-in]	P _e [HP]	F _{Ra} ¹⁾ [lb]	F _{Re} [lb]	Stages		φ _(/R) [']			F87R57	AD2
						Lg	Sm					
193	8.8	26550	3.9	4450	270	2	2	-	-			
211	8.1	26550	3.6	4450	290	2	2	-	-			
240	7.1	26550	3.2	4450	300	2	2	-	-			
249	6.8	26550	3.1	4450	340	3	2	-	-			
281	6.0	26550	2.7	4450	330	2	2	-	-			
300	5.7	26550	2.6	4450	350	3	2	-	-			
315	5.4	26550	2.4	4450	330	2	2	-	-			
345	4.9	26550	2.2	4450	350	3	2	-	-			
350	4.9	26550	2.2	4450	340	2	2	-	-			
398	4.3	26550	1.9	4450	340	2	2	-	-			
452	3.8	26550	1.7	4450	350	3	2	-	-			
468	3.6	26550	1.6	4450	240	2	2	-	-			
515	3.3	26550	1.5	4450	330	3	2	-	-			
519	3.3	26550	1.5	4450	270	2	2	-	-			
592	2.9	26550	1.3	4450	280	2	2	-	-			
609	2.8	26550	1.3	4450	350	3	2	-	-			
662	2.6	26550	1.1	4450	300	2	2	-	-			
674	2.5	26550	1.1	4450	370	3	2	-	-			
748	2.3	26550	1.0	4450	370	2	3	-	-			
780	2.2	26550	0.99	4450	370	3	2	-	-			
883	1.9	26550	0.87	4450	370	2	3	-	-			
887	1.9	26550	0.87	4450	370	3	2	-	-			
988	1.7	26550	0.78	4450	380	2	3	-	-			
1010	1.7	26550	0.76	4450	380	3	2	-	-			
1142	1.5	26550	0.68	4450	380	2	3	-	-			
1148	1.5	26550	0.67	4450	380	3	2	-	-			
1278	1.3	26550	0.60	4450	380	2	3	-	-			
1300	1.3	26550	0.59	4450	380	3	2	-	-			
1476	1.2	26550	0.52	4450	380	2	3	-	-			
1493	1.1	26550	0.52	4450	380	3	2	-	-			
1709	1.0	26550	0.45	4450	380	3	2	-	-			
1717	1.0	26550	0.45	4450	390	2	3	-	-			
1913	1.0	26550	0.40	4450	390	2	3	-	-			
1930	0.88	26550	0.40	4450	390	3	2	-	-			
2134	0.80	26550	0.36	4450	390	2	3	-	-			
2199	0.77	26550	0.35	4450	390	3	2	-	-			
2524	0.67	26550	0.31	4450	390	2	3	-	-			
2576	0.66	26550	0.30	4450	390	3	2	-	-			
2857	0.60	26550	0.27	4450	390	2	3	-	-			
2881	0.59	26550	0.27	4450	390	3	2	-	-			
3196	0.53	26550	0.24	4450	390	2	3	-	-			
3244	0.52	26550	0.24	4450	390	3	2	-	-			
3503	0.49	26550	0.22	4450	390	2	3	-	-			
3721	0.46	26550	0.21	4450	400	3	3	-	-			
3919	0.43	26550	0.20	4450	390	2	3	-	-			
4245	0.40	26550	0.18	4450	390	3	3	-	-			
4562	0.37	26550	0.17	4450	390	2	3	-	-			
4952	0.34	26550	0.16	4450	390	2	3	-	-			
4954	0.34	26550	0.16	4450	390	3	3	-	-			
5510	0.31	26550	0.14	4450	400	3	3	-	-			
6273	0.27	26550	0.12	4450	400	3	3	-	-			
7100	0.24	26550	0.11	4450	400	3	3	-	-			
8142	0.21	26550	0.10	4450	400	3	3	-	-			
9381	0.18	26550	0.08	4450	400	3	3	-	-			
10433	0.16	26550	0.08	4450	400	3	3	-	-			
12205	0.14	26550	0.06	4450	400	3	3	-	-			
14099	0.12	26550	0.06	4450	400	3	3	-	-			
15877	0.11	26550	0.05	4450	400	3	3	-	-			



F87R57 AD.. , n_e = 1700 rpm 26550 lb-in

i [ratio]	n _a [rpm]	T _a max [lb-in]	P _e [HP]	F _{Ra} ¹⁾ [lb]	F _{Re} [lb]	Stages		φ _(/R) [']			
						Lg	Sm				
18238	0.09	26550	0.04	4450	400	3	3	-	-	F87R57	
20462	0.08	26550	0.04	4450	400	3	3	-	-		AD2
23042	0.07	26550	0.03	4450	400	3	3	-	-		
193	8.8	26550	3.9	4450	490	2	2	-	-	F87R57	
211	8.1	26550	3.6	4450	510	2	2	-	-		AD3
240	7.1	26550	3.2	4450	510	2	2	-	-		
249	6.8	26550	3.1	4450	550	3	2	-	-		
281	6.0	26550	2.7	4450	540	2	2	-	-		
300	5.7	26550	2.6	4450	560	3	2	-	-		
315	5.4	26550	2.4	4450	540	2	2	-	-		
345	4.9	26550	2.2	4450	560	3	2	-	-		
350	4.9	26550	2.2	4450	550	2	2	-	-		
398	4.3	26550	1.9	4450	550	2	2	-	-		
452	3.8	26550	1.7	4450	560	3	2	-	-		
468	3.6	26550	1.6	4450	550	2	2	-	-		
515	3.3	26550	1.5	4450	570	3	2	-	-		
519	3.3	26550	1.5	4450	560	2	2	-	-		
609	2.8	26550	1.3	4450	580	3	2	-	-		
674	2.5	26550	1.1	4450	580	3	2	-	-		
748	2.3	26550	1.0	4450	580	2	3	-	-		
780	2.2	26550	0.99	4450	580	3	2	-	-		
883	1.9	26550	0.87	4450	590	2	3	-	-		F87R57
887	1.9	26550	0.87	4450	580	3	2	-	-		AD3
988	1.7	26550	0.78	4450	590	2	3	-	-		
1010	1.7	26550	0.76	4450	590	3	2	-	-		
1142	1.5	26550	0.68	4450	590	2	3	-	-		
1148	1.5	26550	0.67	4450	590	3	2	-	-		
1278	1.3	26550	0.60	4450	590	2	3	-	-		
1300	1.3	26550	0.59	4450	600	3	2	-	-		
1717	0.99	26550	0.45	4450	600	2	3	-	-		
1913	0.89	26550	0.40	4450	600	2	3	-	-		
1930	0.88	26550	0.40	4450	600	3	2	-	-		
2134	0.80	26550	0.36	4450	600	2	3	-	-		
2524	0.67	26550	0.31	4450	600	2	3	-	-		
3721	0.46	26550	0.21	4450	610	3	3	-	-		
4245	0.40	26550	0.18	4450	610	3	3	-	-		
5510	0.31	26550	0.14	4450	610	3	3	-	-		
6273	0.27	26550	0.12	4450	610	3	3	-	-		
8142	0.21	26550	0.10	4450	610	3	3	-	-		
9381	0.18	26550	0.08	4450	610	3	3	-	-		
10433	0.16	26550	0.08	4450	610	3	3	-	-		



Weight [lbs]	Stages		AD2	AD3
	Large	Small		
F87R57	2	2	262	269
	2	3	265	271
	3	2	269	276
	3	3	271	278

FA87: -13 lb / FAF87: +15 lbs / FF87: +34 lbs

9.2.12 F97

F97 AD.. , $n_e = 1700$ rpm										38100 lb-in		
i [ratio]	n_a [rpm]	$T_{a \max}$ [lb-in]	P_e [HP]	$F_{Ra}^{(1)}$ [lb]	F_{Re} [lb]	Stages		ϕ (/R) [']				
						Lg	Sm					
72.29	24	38100	14.9	6200	280	3	-	6	-			
75.63	22	38100	14.2	6350	380	3	-	6	-			
80.31	21	38100	13.4	6540	290	3	-	6	-			
86.59	20	38100	12.4	6720	390	3	-	6	-			
89.85	19	38100	12.0	6720	290	3	-	6	-			
97.58	17	38100	11.0	6720	300	3	-	6	-			
102.16	17	38100	10.5	6720	410	3	-	6	-			
112.99	15	38100	9.5	6720	410	3	-	6	-			
127.42	13	38100	8.4	6720	420	3	-	6	-			
140.71	12	38100	7.6	6720	430	3	-	6	-			
156.30	11	38100	6.9	6720	430	3	-	6	-			
174.87	9.7	38100	6.1	6720	440	3	-	6	-			
189.92	9.0	38100	5.7	6720	440	3	-	6	-			
223.88	7.6	38100	4.8	6720	440	3	-	6	-			
253.41	6.7	38100	4.2	6720	450	3	-	6	-			
276.77	6.1	38100	3.9	6720	450	3	-	6	-			
32.50	52	38100	33	3960	610	3	-	6	M1-6			
33.91	50	31330	26	4660	320	2	-	6	-			
36.64	46	27170	21	5230	500	2	-	6	-			
38.86	44	38100	28	4410	640	3	-	6	M2,5-6			
43.28	39	27170	17.5	5660	530	2	-	6	-			
44.49	38	38100	24	4770	660	3	-	6	-			
52.49	32	38100	20	5230	680	3	-	6	-			
58.06	29	38100	18.5	5530	690	3	-	6	-			
65.47	26	38100	16.4	5890	700	3	-	6	-			
72.29	24	38100	14.9	6200	710	3	-	6	-			
75.63	22	38100	14.2	6350	810	3	-	6	-			
80.31	21	38100	13.4	6540	720	3	-	6	-			
86.59	20	38100	12.4	6720	820	3	-	6	-			
89.85	19	38100	12.0	6720	720	3	-	6	-			
97.58	17	38100	11.0	6720	730	3	-	6	-			
102.16	17	38100	10.5	6720	830	3	-	6	-			
112.99	15	38100	9.5	6720	830	3	-	6	-			
127.42	13	38100	8.4	6720	840	3	-	6	-			
140.71	12	38100	7.6	6720	840	3	-	6	-			
156.30	11	38100	6.9	6720	850	3	-	6	-			
174.87	9.7	38100	6.1	6720	850	3	-	6	-			
189.92	9.0	38100	5.7	6720	860	3	-	6	-			
223.88	7.6	38100	4.8	6720	860	3	-	6	-			
3.87	439	10440	75	2560	970	2	-	9	M1-6			
4.57	372	12390	75	2570	890	2	-	9	M1-6			
5.23	325	14160	75	2560	840	2	-	9	M1-6			
6.17	276	16730	75	2530	650	2	-	9	M1-6			
7.07	240	17790	70	2610	610	2	-	9	M1-6			
8.22	207	19030	64	2720	570	2	-	9	M1-6			
9.06	188	19820	61	2790	540	2	-	9	M1-6			
11.16	152	30270	75	2450	890	2	-	6	M1-6			
12.77	133	34690	76	2290	830	2	-	6	M1-6			
15.06	113	38100	70	2300	780	2	-	6	M1-6			
17.25	99	38100	61	2560	850	2	-	6	M1-6			
20.07	85	38100	53	2870	890	2	-	6	M1-6			
22.11	77	38100	48	3070	920	2	-	6	M2			
24.92	68	38100	42	3340	940	2	-	6	-			
27.44	62	38100	39	3560	960	2	-	6	-			
30.39	56	38100	35	3800	980	2	-	6	-			



F97 AD.. , n_e = 1700 rpm 38100 lb-in

i [ratio]	n _a [rpm]	T _{a max} [lb-in]	P _e [HP]	F _{Ra} ¹⁾ [lb]	F _{Re} [lb]	Stages		φ (°/R) [']		
						Lg	Sm			
32.50	52	38100	33	3960	1290	3	-	6	M1-6	F97 AD5
33.91	50	38100	31	4060	1000	2	-	6	-	
38.86	44	38100	28	4410	1320	3	-	6	M2,5-6	
44.49	38	38100	24	4770	1330	3	-	6	-	
52.49	32	38100	20	5230	1350	3	-	6	-	
58.06	29	38100	18.5	5530	1360	3	-	6	-	
65.47	26	38100	16.4	5890	1370	3	-	6	-	
72.29	24	38100	14.9	6200	1380	3	-	6	-	
75.63	22	38100	14.2	6350	1480	3	-	6	-	
80.31	21	38100	13.4	6540	1390	3	-	6	-	
86.59	20	38100	12.4	6720	1490	3	-	6	-	
89.85	19	38100	12.0	6720	1390	3	-	6	-	
102.16	17	38100	10.5	6720	1500	3	-	6	-	
112.99	15	38100	9.5	6720	1500	3	-	6	-	
127.42	13	38100	8.4	6720	1510	3	-	6	-	
140.71	12	38100	7.6	6720	1510	3	-	6	-	
156.30	11	38100	6.9	6720	1510	3	-	6	-	
174.87	9.7	38100	6.1	6720	1520	3	-	6	-	
3.87	439	12660	91	2330	1450	2	-	9	M1-6	F97 AD6
4.57	372	14960	91	2310	1370	2	-	9	M1-6	
5.23	325	17080	91	2270	1310	2	-	9	M1-6	
6.17	276	19910	90	2200	1130	2	-	9	M1-6	
7.07	240	20890	82	2300	1110	2	-	9	M1-6	
8.22	207	20890	71	2530	1220	2	-	9	M1-6	
9.06	188	20890	64	2680	1280	2	-	9	M1-6	
11.16	152	36290	90	1910	1380	2	-	6	M1-6	
12.77	133	38100	83	1990	1390	2	-	6	M1-6	
15.06	113	38100	70	2300	1440	2	-	6	M1-6	
17.25	99	38100	61	2560	1480	2	-	6	M1-6	
20.07	85	38100	53	2870	1520	2	-	6	M1-6	
22.11	77	38100	48	3070	1540	2	-	6	M2	
24.92	68	38100	42	3340	1560	2	-	6	-	
27.44	62	38100	39	3560	1570	2	-	6	-	
32.50	52	38100	33	3960	1890	3	-	6	M1-6	
38.86	44	38100	28	4410	1910	3	-	6	M2,5-6	
44.49	38	38100	24	4770	1930	3	-	6	-	
52.49	32	38100	20	5230	1950	3	-	6	-	
58.06	29	38100	18.5	5530	1960	3	-	6	-	
65.47	26	38100	16.4	5890	1970	3	-	6	-	
72.29	24	38100	14.9	6200	1970	3	-	6	-	
75.63	22	38100	14.2	6350	2060	3	-	6	-	
86.59	20	38100	12.4	6720	2070	3	-	6	-	
102.16	17	38100	10.5	6720	2080	3	-	6	-	
112.99	15	38100	9.5	6720	2090	3	-	6	-	
127.42	13	38100	8.4	6720	2090	3	-	6	-	
140.71	12	38100	7.6	6720	2090	3	-	6	-	

Weight [lbs]	Stages		AD3	AD4	AD5	AD6
	Large	Small				
F97	2	-	360	371	408	438
	3	-	373	385	421	451

FA97: -17 lb / FAF97: +31 lbs / FF97: +72 lbs



9.2.13 F97R57

F97R57 AD.. , n _e = 1700 rpm										38100 lb-in		
i [ratio]	n _a [rpm]	T _a max [lb-in]	P _e [HP]	F _{Ra} ¹⁾ [lb]	F _{Re} [lb]	Stages		φ _(/R) [']				
						Lg	Sm					
195	8.7	38100	5.7	6720	280	3	2	-	-			
208	8.2	38100	5.3	6720	260	3	2	-	-			
242	7.0	38100	4.5	6720	270	2	2	-	-			
275	6.2	38100	4.0	6720	270	2	2	-	-			
285	6.0	38100	3.9	6720	300	3	2	-	-			
317	5.4	38100	3.4	6720	320	2	2	-	-			
361	4.7	38100	3.0	6720	320	2	2	-	-			
403	4.2	38100	2.7	6720	330	2	2	-	-			
406	4.2	38100	2.7	6720	340	3	2	-	-			
467	3.6	38100	2.4	6720	340	3	2	-	-			
473	3.6	38100	2.3	6720	340	2	2	-	-			
510	3.3	38100	2.1	6720	330	2	2	-	-			
529	3.2	38100	2.1	6720	350	3	2	-	-			
569	3.0	38100	1.9	6720	340	2	2	-	-			
605	2.8	38100	1.8	6720	350	3	2	-	-			
667	2.5	38100	1.6	6720	340	2	2	-	-			
690	2.5	38100	1.6	6720	330	3	2	-	-			
760	2.2	38100	1.4	6720	250	2	2	-	-			
784	2.2	38100	1.4	6720	310	3	2	-	-			
892	1.9	38100	1.2	6720	280	2	2	-	-			
898	1.9	38100	1.2	6720	370	3	2	-	-			
1022	1.7	38100	1.1	6720	300	3	2	-	-			
1023	1.7	38100	1.1	6720	370	2	3	-	-			
1171	1.5	38100	0.95	6720	330	3	2	-	-			
1189	1.4	38100	0.93	6720	370	2	3	-	-			
1316	1.3	38100	0.84	6720	370	2	3	-	-			
1327	1.3	38100	0.83	6720	380	3	2	-	-			
1468	1.2	38100	0.75	6720	380	2	3	-	-			
1527	1.1	38100	0.73	6720	370	3	2	-	-			
1722	0.99	38100	0.64	6720	370	3	2	-	-			
1741	0.98	38100	0.64	6720	380	2	3	-	-			
1970	0.86	38100	0.56	6720	380	3	2	-	-			
1971	0.86	38100	0.56	6720	380	2	3	-	-			
2199	0.77	38100	0.50	6720	380	2	3	-	-			
2245	0.76	38100	0.49	6720	380	3	2	-	-			
2448	0.69	38100	0.45	6720	390	2	3	-	-			
2553	0.67	38100	0.43	6720	380	3	2	-	-			
2907	0.58	38100	0.38	6720	390	3	2	-	-			
3009	0.56	38100	0.37	6720	390	2	3	-	-			
3352	0.51	38100	0.33	6720	390	3	2	-	-			
3357	0.51	38100	0.33	6720	390	2	3	-	-			
3906	0.44	38100	0.28	6720	390	3	2	-	-			
3914	0.43	38100	0.28	6720	390	2	3	-	-			
4333	0.39	38100	0.26	6720	390	3	3	-	-			
4367	0.39	38100	0.25	6720	390	2	3	-	-			
4961	0.34	38100	0.23	6720	390	3	3	-	-			
5016	0.34	38100	0.22	6720	390	2	3	-	-			
5615	0.30	38100	0.20	6720	390	3	3	-	-			
5680	0.30	38100	0.19	6720	390	2	3	-	-			
6338	0.27	38100	0.17	6720	390	2	3	-	-			
6469	0.26	38100	0.17	6720	400	3	3	-	-			
7328	0.23	38100	0.15	6720	390	3	3	-	-			
8318	0.20	38100	0.14	6720	400	3	3	-	-			
9576	0.18	38100	0.12	6720	400	3	3	-	-			
10838	0.16	38100	0.10	6720	400	3	3	-	-			
12324	0.14	38100	0.09	6720	400	3	3	-	-			
14022	0.12	38100	0.08	6720	400	3	3	-	-			

F97R57

AD2



F97R57 AD.. , n_e = 1700 rpm 38100 lb-in

i [ratio]	n _a [rpm]	T _{a max} [lb-in]	P _e [HP]	F _{Ra} ¹⁾ [lb]	F _{Re} [lb]	Stages		φ ^(/R) [']		
						Lg	Sm			
15472	0.11	38100	0.07	6720	400	3	3	-	-	F97R57 AD2
18119	0.09	38100	0.06	6720	400	3	3	-	-	
20813	0.08	38100	0.05	6720	400	3	3	-	-	
23814	0.07	38100	0.05	6720	400	3	3	-	-	
26911	0.06	38100	0.04	6720	400	3	3	-	-	
29211	0.06	38100	0.04	6720	400	3	3	-	-	
195	8.7	38100	5.7	6720	500	3	2	-	-	F97R57 AD3
208	8.2	38100	5.3	6720	480	3	2	-	-	
242	7.0	38100	4.5	6720	480	2	2	-	-	
275	6.2	38100	4.0	6720	490	2	2	-	-	
285	6.0	38100	3.9	6720	510	3	2	-	-	
317	5.4	38100	3.4	6720	540	2	2	-	-	
361	4.7	38100	3.0	6720	540	2	2	-	-	
403	4.2	38100	2.7	6720	540	2	2	-	-	
406	4.2	38100	2.7	6720	550	3	2	-	-	
467	3.6	38100	2.4	6720	560	3	2	-	-	
473	3.6	38100	2.3	6720	550	2	2	-	-	
510	3.3	38100	2.1	6720	540	2	2	-	-	
529	3.2	38100	2.1	6720	560	3	2	-	-	
569	3.0	38100	1.9	6720	550	2	2	-	-	
605	2.8	38100	1.8	6720	560	3	2	-	-	
667	2.5	38100	1.6	6720	550	2	2	-	-	
690	2.5	38100	1.6	6720	570	3	2	-	-	
784	2.2	38100	1.4	6720	570	3	2	-	-	
898	1.9	38100	1.2	6720	580	3	2	-	-	
1023	1.7	38100	1.1	6720	580	2	3	-	-	
1189	1.4	38100	0.93	6720	590	2	3	-	-	
1316	1.3	38100	0.84	6720	590	2	3	-	-	
1327	1.3	38100	0.83	6720	590	3	2	-	-	
1468	1.2	38100	0.75	6720	590	2	3	-	-	
1741	0.98	38100	0.64	6720	590	2	3	-	-	
1970	0.86	38100	0.56	6720	590	3	2	-	-	
2448	0.69	38100	0.45	6720	600	2	3	-	-	
2907	0.58	38100	0.38	6720	600	3	2	-	-	
4333	0.39	38100	0.26	6720	600	3	3	-	-	
4961	0.34	38100	0.23	6720	600	3	3	-	-	
6469	0.26	38100	0.17	6720	610	3	3	-	-	
9576	0.18	38100	0.12	6720	610	3	3	-	-	
14022	0.12	38100	0.08	6720	610	3	3	-	-	



Weight [lbs]	Stages		AD2	AD3
	Large	Small		
F97R57	2	2	404	411
	2	3	406	413
	3	2	417	424
	3	3	419	426

FA97: -17 lb / FAF97: +31 lbs / FF97: +72 lbs

9.2.14 F107

F107 AD.. , n _e = 1700 rpm										69400 lb-in	
i [ratio]	n _a [rpm]	T _{a max} [lb-in]	P _e [HP]	F _{Ra} ¹⁾ [lb]	F _{Re} [lb]	Stages		φ (/R) [']			
						Lg	Sm				
117.94	14	67970	16.3	11200	320	3	-	5	-		
129.97	13	67970	14.8	11200	330	3	-	5	-		
146.49	12	67970	13.1	11200	340	3	-	5	-		
161.28	11	67970	11.9	11200	350	3	-	5	-		
178.64	9.5	67970	10.7	11200	360	3	-	5	-		
199.31	8.5	67970	9.6	11200	370	3	-	5	-		
215.37	7.9	67970	8.9	11200	370	3	-	5	-		
254.40	6.7	67970	7.5	11200	380	3	-	5	-		
50.73	34	67970	38	9310	530	3	-	6	M2-6		
58.12	29	67970	33	9890	550	3	-	6	M2,5-6		
67.62	25	67970	28	10560	580	3	-	6	-		
74.52	23	67970	26	11010	590	3	-	6	-		
83.99	20	67970	23	11200	600	3	-	6	-		
88.49	19	67970	22	11200	720	3	-	5	M2		
92.47	18	67970	21	11200	610	3	-	6	-		
101.38	17	67970	18.9	11200	740	3	-	5	-		
117.94	14	67970	16.3	11200	750	3	-	5	-		
129.97	13	67970	14.8	11200	760	3	-	5	-		
146.49	12	67970	13.1	11200	770	3	-	5	-		
161.28	11	67970	11.9	11200	770	3	-	5	-		
178.64	9.5	67970	10.7	11200	780	3	-	5	-		
199.31	8.5	67970	9.6	11200	790	3	-	5	-		
215.37	7.9	67970	8.9	11200	790	3	-	5	-		
254.40	6.7	67970	7.5	11200	800	3	-	5	-		
31.80	53	67970	60	7400	1110	3	-	6	M1-6		
33.79	50	64520	53	7950	490	2	-	5	-		
37.61	45	67970	51	8110	1150	3	-	6	M1-6		
43.03	40	67970	45	8640	1180	3	-	6	M1-6		
50.73	34	67970	38	9310	1210	3	-	6	M2-6		
58.12	29	67970	33	9890	1230	3	-	6	M2,5-6		
67.62	25	67970	28	10560	1250	3	-	6	-		
74.52	23	67970	26	11010	1260	3	-	6	-		
83.99	20	67970	23	11200	1280	3	-	6	-		
88.49	19	67970	22	11200	1400	3	-	5	M2		
92.47	18	67970	21	11200	1290	3	-	6	-		
101.38	17	67970	18.9	11200	1410	3	-	5	-		
117.94	14	67970	16.3	11200	1420	3	-	5	-		
129.97	13	67970	14.8	11200	1430	3	-	5	-		
146.49	12	67970	13.1	11200	1430	3	-	5	-		
161.28	11	67970	11.9	11200	1440	3	-	5	-		
178.64	9.5	67970	10.7	11200	1450	3	-	5	-		
199.31	8.5	67970	9.6	11200	1450	3	-	5	-		



F107 AD.. , n_e = 1700 rpm 69400 lb-in

i [ratio]	n _a [rpm]	T _{a max} [lb-in]	P _e [HP]	F _{Ra} ¹⁾ [lb]	F _{Re} [lb]	Stages		φ (°/R) [']		
						Lg	Sm			
5.03	338	17880	99	5610	1470	2	-	7	M1-6	F107 AD6
6.22	273	20270	91	5890	1460	2	-	7	M1-6	
7.40	230	24160	91	6000	1370	2	-	7	M1-6	
8.37	203	27350	91	6050	1310	2	-	7	M1-6	
9.69	175	31680	91	6060	1090	2	-	7	M1-6	
9.96	171	35400	99	6140	1470	2	-	5	M1-6	
12.33	138	40180	91	6380	1460	2	-	5	M1-6	
14.67	116	47880	91	6340	1370	2	-	5	M1-6	
16.58	103	54160	91	6260	1310	2	-	5	M1-6	
19.20	89	62750	91	5910	1090	2	-	5	M1-6	
21.76	78	69400	89	5670	920	2	-	5	M1-6	
25.14	68	69400	77	6260	1020	2	-	5	M1-6	
27.57	62	69400	70	6640	1070	2	-	5	M1-6	
31.80	53	67970	60	7400	1720	3	-	6	M1-6	
33.79	50	65490	54	7880	1300	2	-	5	-	
37.61	45	67970	51	8110	1760	3	-	6	M1-6	
43.03	40	67970	45	8640	1780	3	-	6	M1-6	
50.73	34	67970	38	9310	1810	3	-	6	M2-6	
58.12	29	67970	33	9890	1830	3	-	6	M2,5-6	
67.62	25	67970	28	10560	1850	3	-	6	-	
74.52	23	67970	26	11010	1860	3	-	6	-	
83.99	20	67970	23	11200	1870	3	-	6	-	
88.49	19	67970	22	11200	1990	3	-	5	M2	
92.47	18	67970	21	11200	1880	3	-	6	-	
101.38	17	67970	18.9	11200	2000	3	-	5	-	
117.94	14	67970	16.3	11200	2010	3	-	5	-	
129.97	13	67970	14.8	11200	2020	3	-	5	-	
146.49	12	67970	13.1	11200	2020	3	-	5	-	
161.28	11	67970	11.9	11200	2030	3	-	5	-	



Weight [lbs]	Stages		AD3	AD4	AD5	AD6
	Large	Small				
F107	2	-	538	552	581	612
	3	-	560	574	603	633

FA107: -37 lb / FAF107: +10 lbs / FF107: +60 lbs

9.2.15 F107R57

F107R57 AD.. , n_e = 1700 rpm										69400 lb-in		
i [ratio]	n_a [rpm]	T_a max [lb-in]	P_e [HP]	F_{Ra}¹⁾ [lb]	F_{Re} [lb]	Stages		φ_(/R) [']				
						Lg	Sm					
190	8.9	60530	9.3	11690	210	3	2	-	-			
225	7.6	67970	8.8	11200	220	3	2	-	-			
255	6.7	67970	7.8	11200	230	3	2	-	-			
266	6.4	69400	7.5	11100	250	2	2	-	-			
291	5.8	67970	6.8	11200	240	3	2	-	-			
300	5.7	69400	6.6	11100	260	2	2	-	-			
333	5.1	67970	5.9	11200	260	3	2	-	-			
340	5	69400	5.8	11100	270	2	2	-	-			
370	4.6	67970	5.3	11200	260	3	2	-	-			
387	4.4	69400	5.1	11100	280	2	2	-	-			
430	4	69400	4.6	11100	280	2	2	-	-			
436	3.9	67970	4.5	11200	280	3	2	-	-			
491	3.5	69400	4.0	11100	290	2	2	-	-			
518	3.3	69400	3.8	11100	290	2	2	-	-			
560	3	67970	3.5	11200	330	3	2	-	-			
591	2.9	69400	3.4	11100	290	2	2	-	-			
640	2.7	67970	3.1	11200	320	3	2	-	-			
644	2.6	69400	3.1	11100	300	2	2	-	-			
696	2.4	69400	2.9	11100	340	2	3	-	-			
736	2.3	67970	2.7	11200	340	3	2	-	-			
800	2.1	69400	2.5	11100	350	2	3	-	-			
834	2	67970	2.4	11200	350	3	2	-	-			
923	1.8	69400	2.2	11100	350	2	3	-	-			
950	1.8	67970	2.1	11200	350	3	2	-	-			
1015	1.7	69400	2.0	11100	350	2	3	-	-			
1087	1.6	67970	1.8	11200	340	3	2	-	-			
1193	1.4	69400	1.7	11100	360	2	3	-	-			
1243	1.4	67970	1.6	11200	360	3	2	-	-			
1263	1.3	69400	1.6	11100	310	2	3	-	-			
1401	1.2	67970	1.4	11200	330	3	2	-	-			
1436	1.2	69400	1.4	11100	320	2	3	-	-			
1590	1.1	69400	1.3	11100	320	2	3	-	-			
1597	1.1	67970	1.2	11200	340	3	2	-	-			
1813	0.94	69400	1.1	11100	370	2	3	-	-			
1826	0.93	67970	1.1	11200	370	3	2	-	-			
2068	0.82	67970	0.96	11200	360	3	2	-	-			
2129	0.8	69400	0.95	11100	380	2	3	-	-			
2255	0.75	69400	0.90	11100	380	2	3	-	-			
2369	0.72	67970	0.83	11200	370	3	2	-	-			
2563	0.66	69400	0.79	11100	380	2	3	-	-			
2756	0.62	67970	0.72	11200	380	3	2	-	-			
2839	0.6	69400	0.71	11100	380	2	3	-	-			
3037	0.56	67970	0.65	11200	380	3	2	-	-			
3347	0.51	69400	0.60	11100	380	2	3	-	-			
3521	0.48	67970	0.57	11200	380	3	3	-	-			
3815	0.45	69400	0.53	11100	380	2	3	-	-			
3948	0.43	67970	0.51	11200	390	3	3	-	-			
4016	0.42	69400	0.50	11100	380	2	3	-	-			
4567	0.37	67970	0.44	11200	380	3	3	-	-			
4593	0.37	69400	0.44	11100	380	2	3	-	-			
5223	0.33	67970	0.38	11200	390	3	3	-	-			
5383	0.32	69400	0.37	11100	380	2	3	-	-			
5954	0.29	67970	0.34	11200	390	3	3	-	-			
6767	0.25	67970	0.30	11200	390	3	3	-	-			
7674	0.22	67970	0.26	11200	390	3	3	-	-			
8548	0.2	67970	0.23	11200	390	3	3	-	-			
10039	0.17	67970	0.20	11200	400	3	3	-	-			
11348	0.15	67970	0.18	11200	390	3	3	-	-			
14767	0.12	67970	0.14	11200	390	3	3	-	-			

F107R77 AD2



F107R57 AD.. , n _e = 1700 rpm										69400 lb-in	
i [ratio]	n _a [rpm]	T _a max [lb-in]	P _e [HP]	F _{Ra} ¹⁾ [lb]	F _{Re} [lb]	Stages		φ ^(/R) [']			
						Lg	Sm				
16888	0.1	67970	0.12	11200	390	3	3	-	-		
18933	0.09	67970	0.11	11200	400	3	3	-	-		
21652	0.08	67970	0.09	11200	400	3	3	-	-		F107R77 AD2
25375	0.07	67970	0.08	11200	400	3	3	-	-		
190	8.9	67970	10.4	11200	410	3	2	-	-		
225	7.6	67970	8.8	11200	440	3	2	-	-		
255	6.7	67970	7.8	11200	450	3	2	-	-		
266	6.4	69400	7.5	11100	470	2	2	-	-		
291	5.8	67970	6.8	11200	450	3	2	-	-		
300	5.7	69400	6.6	11100	480	2	2	-	-		
333	5.1	67970	5.9	11200	470	3	2	-	-		
340	5	69400	5.8	11100	490	2	2	-	-		
370	4.6	67970	5.3	11200	480	3	2	-	-		
387	4.4	69400	5.1	11100	490	2	2	-	-		
430	4	69400	4.6	11100	500	2	2	-	-		
436	3.9	67970	4.5	11200	500	3	2	-	-		
491	3.5	69400	4.0	11100	500	2	2	-	-		
518	3.3	69400	3.8	11100	500	2	2	-	-		
560	3	67970	3.5	11200	550	3	2	-	-		
591	2.9	69400	3.4	11100	510	2	2	-	-		
640	2.7	67970	3.1	11200	540	3	2	-	-		
644	2.6	69400	3.1	11100	510	2	2	-	-		
696	2.4	69400	2.9	11100	560	2	3	-	-		
736	2.3	67970	2.7	11200	560	3	2	-	-		
800	2.1	69400	2.5	11100	560	2	3	-	-		
834	2	67970	2.4	11200	560	3	2	-	-		
923	1.8	69400	2.2	11100	560	2	3	-	-		
950	1.8	67970	2.1	11200	560	3	2	-	-		
1015	1.7	69400	2.0	11100	560	2	3	-	-		
1087	1.6	67970	1.8	11200	560	3	2	-	-		
1193	1.4	69400	1.7	11100	570	2	3	-	-		F107R77 AD3
1243	1.4	67970	1.6	11200	580	3	2	-	-		
1263	1.3	69400	1.6	11100	570	2	3	-	-		
1401	1.2	67970	1.4	11200	570	3	2	-	-		
1436	1.2	69400	1.4	11100	570	2	3	-	-		
1590	1.1	69400	1.3	11100	570	2	3	-	-		
1597	1.1	67970	1.2	11200	570	3	2	-	-		
1813	0.94	69400	1.1	11100	590	2	3	-	-		
1826	0.93	67970	1.1	11200	590	3	2	-	-		
2068	0.82	67970	0.96	11200	580	3	2	-	-		
2129	0.8	69400	0.95	11100	590	2	3	-	-		
2255	0.75	69400	0.90	11100	590	2	3	-	-		
2369	0.72	67970	0.83	11200	580	3	2	-	-		
2563	0.66	69400	0.79	11100	590	2	3	-	-		
2756	0.62	67970	0.72	11200	590	3	2	-	-		
2839	0.6	69400	0.71	11100	590	2	3	-	-		
3037	0.56	67970	0.65	11200	590	3	2	-	-		
3347	0.51	69400	0.60	11100	590	2	3	-	-		
3521	0.48	67970	0.57	11200	600	3	3	-	-		
3948	0.43	67970	0.51	11200	600	3	3	-	-		
4567	0.37	67970	0.44	11200	600	3	3	-	-		
5223	0.33	67970	0.38	11200	600	3	3	-	-		
5954	0.29	67970	0.34	11200	600	3	3	-	-		
6767	0.25	67970	0.30	11200	600	3	3	-	-		
7674	0.22	67970	0.26	11200	600	3	3	-	-		
8548	0.2	67970	0.23	11200	610	3	3	-	-		
10039	0.17	67970	0.20	11200	610	3	3	-	-		

9 F - theSnuggler® Helical

F.. AD

F107R57 AD.. , $n_e = 1700$ rpm



69400 lb-in

i [ratio]	n_a [rpm]	T_a max [lb-in]	P_e [HP]	$F_{Ra}^{1)}$ [lb]	F_{Re} [lb]	Stages		ϕ (°/R) [']		
						Lg	Sm			
190	8.9	67970	10.4	11200	810	3	2	-	-	
225	7.6	67970	8.8	11200	830	3	2	-	-	
255	6.7	67970	7.8	11200	840	3	2	-	-	
266	6.4	69400	7.5	11100	870	2	2	-	-	
291	5.8	67970	6.8	11200	850	3	2	-	-	
300	5.7	69400	6.6	11100	870	2	2	-	-	
333	5.1	67970	5.9	11200	870	3	2	-	-	
340	5	69400	5.8	11100	880	2	2	-	-	
370	4.6	67970	5.3	11200	870	3	2	-	-	
387	4.4	69400	5.1	11100	880	2	2	-	-	
430	4	69400	4.6	11100	890	2	2	-	-	
436	3.9	67970	4.5	11200	890	3	2	-	-	
491	3.5	69400	4.0	11100	890	2	2	-	-	
518	3.3	69400	3.8	11100	890	2	2	-	-	
560	3	67970	3.5	11200	930	3	2	-	-	
640	2.7	67970	3.1	11200	920	3	2	-	-	
696	2.4	69400	2.9	11100	940	2	3	-	-	
736	2.3	67970	2.7	11200	940	3	2	-	-	
800	2.1	69400	2.5	11100	940	2	3	-	-	F107R77
834	2	67970	2.4	11200	940	3	2	-	-	AD4
923	1.8	69400	2.2	11100	940	2	3	-	-	
950	1.8	67970	2.1	11200	940	3	2	-	-	
1015	1.7	69400	2.0	11100	950	2	3	-	-	
1193	1.4	69400	1.7	11100	950	2	3	-	-	
1243	1.4	67970	1.6	11200	950	3	2	-	-	
1263	1.3	69400	1.6	11100	950	2	3	-	-	
1401	1.2	67970	1.4	11200	950	3	2	-	-	
1813	0.94	69400	1.1	11100	960	2	3	-	-	
1826	0.93	67970	1.1	11200	960	3	2	-	-	
2129	0.8	69400	0.95	11100	970	2	3	-	-	
2255	0.75	69400	0.90	11100	970	2	3	-	-	
3948	0.43	67970	0.51	11200	980	3	3	-	-	
5223	0.33	67970	0.38	11200	980	3	3	-	-	
5954	0.29	67970	0.34	11200	980	3	3	-	-	
8548	0.2	67970	0.23	11200	980	3	3	-	-	
10039	0.17	67970	0.20	11200	980	3	3	-	-	

Weight [lbs]	Stages		AD2	AD3	AD4
	Large	Small			
F107R77	2	2	613	621	634
	2	3	616	623	636
	3	2	635	642	656
	3	3	637	645	658

FA107: -37 lb / FAF107: +10 lbs / FF107: +60 lbs

9.2.16 F127



F127 AD.. , n _e = 1700 rpm										106200 lb-in	
i [ratio]	n _a [rpm]	T _a max [lb-in]	P _e [HP]	F _{Ra} ¹⁾ [lb]	F _{Re} [lb]	Stages		φ (/R) [']			
						Lg	Sm				
75.41	23	106200	40	15410	530	3	-	5	M2,5-6	F127	AD4
87.31	19	106200	34	16390	560	3	-	5	M2		
98.95	17	106200	30	17250	580	3	-	5	-		
114.34	15	106200	26	18300	600	3	-	5	-		
125.37	14	106200	24	18990	610	3	-	5	-		
153.67	11	106200	19.5	20230	640	3	-	5	-		
170.83	10	106200	17.5	20230	640	3	-	5	-		
42.15	40	106200	71	11500	880	3	-	5	M1-6	F127	AD5
48.80	35	106200	61	12460	920	3	-	5	M1-6		
55.31	31	106200	54	13300	950	3	-	5	M2-3,5-6		
63.91	27	106200	47	14310	980	3	-	5	-		
70.07	24	106200	43	14940	1000	3	-	5	-		
75.41	23	106200	40	15410	1220	3	-	5	M2,5-6		
87.31	19	106200	34	16390	1240	3	-	5	M2		
98.95	17	106200	30	17250	1250	3	-	5	-		
114.34	15	106200	26	18300	1270	3	-	5	-		
125.37	14	106200	24	18990	1280	3	-	5	-		
153.67	11	106200	19.5	20230	1310	3	-	5	-		
170.83	10	106200	17.5	20230	1320	3	-	5	-		
37.28	46	106200	80	10720	1470	3	-	5	M1-6		
42.15	40	106200	71	11500	1510	3	-	5	M1-6		
48.80	35	106200	61	12460	1540	3	-	5	M1-6		
55.31	31	106200	54	13300	1570	3	-	5	M2-3,5-6		
63.91	27	106200	47	14310	1600	3	-	5	-		
70.07	24	106200	43	14940	1610	3	-	5	-		
75.41	23	106200	40	15410	1820	3	-	5	M2,5-6		
87.31	19	106200	34	16390	1840	3	-	5	M2		
98.95	17	106200	30	17250	1860	3	-	5	-		
114.34	15	106200	26	18300	1870	3	-	5	-		
125.37	14	106200	24	18990	1880	3	-	5	-		
153.67	11	106200	19.5	20230	1900	3	-	5	-		
14.55	117	74070	142	8650	1800	2	-	5	M1-6	F127	AD7
16.36	104	83280	142	8340	1290	2	-	5	M1-6		
18.87	90	92930	137	8130	820	2	-	5	M1-6		
21.38	80	96470	125	8440	770	2	-	5	M1-6		
24.57	69	75230	85	11050	2480	2	-	5	M2-3,5-6		
25.30	67	106200	118	8400	3480	3	-	5	M1-6		
26.86	63	75230	78	11470	2570	2	-	5	-		
31.33	54	106200	96	9660	3560	3	-	5	M1-6		
37.28	46	106200	80	10720	3610	3	-	5	M1-6		
42.15	40	106200	71	11500	3650	3	-	5	M1-6		
48.80	35	106200	61	12460	3680	3	-	5	M1-6		
55.31	31	106200	54	13300	3700	3	-	5	M2-3,5-6		
63.91	27	106200	47	14310	3720	3	-	5	-		
70.07	24	106200	43	14940	3740	3	-	5	-		
75.41	23	106200	40	15410	3910	3	-	5	M2,5-6		
87.31	19	106200	34	16390	3930	3	-	5	M2		
98.95	17	106200	30	17250	3940	3	-	5	-		
114.34	15	106200	26	18300	3960	3	-	5	-		
125.37	14	106200	24	18990	3970	3	-	5	-		

9 F - theSnuggler® Helical

F.. AD

F127 AD.. , $n_e = 1700$ rpm



106200 lb-in

i [ratio]	n_a [rpm]	T_a max [lb-in]	P_e [HP]	$F_{Ra}^{1)}$ [lb]	F_{Re} [lb]	Stages		ϕ (/R) [']		
						Lg	Sm			
4.68	363	36730	218	7100	5110	2	-	7	M1-6	F127 AD8
5.52	308	43370	218	7160	4990	2	-	7	M1-6	
6.80	250	53370	218	7160	4830	2	-	7	M1-6	
7.88	216	53100	187	7660	4910	2	-	6	M1-6	
8.86	192	61950	194	7490	4730	2	-	6	M1-6	
10.19	167	80000	218	6480	5000	2	-	5	M1-6	
12.54	136	88500	196	6550	4990	2	-	5	M1-6	
14.55	117	97350	186	6340	4920	2	-	5	M1-6	
16.36	104	97350	165	6940	4980	2	-	5	M1-6	
18.87	90	95580	141	7860	5070	2	-	5	M1-6	
21.38	80	106200	138	7440	4970	2	-	5	M1-6	
25.30	67	106200	118	8400	5600	3	-	5	M1-6	
31.33	54	106200	96	9660	5680	3	-	5	M1-6	
37.28	46	106200	80	10720	5730	3	-	5	M1-6	
42.15	40	106200	71	11500	5760	3	-	5	M1-6	
48.80	35	106200	61	12460	5790	3	-	5	M1-6	
55.31	31	106200	54	13300	5810	3	-	5	M2-3,5-6	
75.41	23	106200	40	15410	6040	3	-	5	M2,5-6	
87.31	19	106200	34	16390	6060	3	-	5	M2	
98.95	17	106200	30	17250	6070	3	-	5	-	

Weight [lbs]	Stages		AD4	AD5	AD6	AD7	AD8
	Large	Small					
F127	2	-	919	945	971	970	1019
	3	-	946	972	998	997	1045

FA127: -80 lb / FAF127: +2 lbs / FF127: +98 lbs

9.2.17 F127R77



F127R77 AD.. , n _e = 1700 rpm										106200 lb-in		
i [ratio]	n _a [rpm]	T _{a max} [lb-in]	P _e [HP]	F _{RA} ¹⁾ [lb]	F _{Re} [lb]	Stages		φ (/R) [']				
						Lg	Sm					
376	4.5	106200	8.2	20230	220	3	2	-	-			
428	4	106200	7.2	20230	230	3	2	-	-			
495	3.4	106200	6.2	20230	250	3	2	-	-			
549	3.1	106200	5.6	20230	260	3	2	-	-			
648	2.6	106200	4.8	20230	280	3	2	-	-			
727	2.3	106200	4.2	20230	320	3	2	-	-			
820	2.1	106200	3.8	20230	320	3	2	-	-			
930	1.8	106200	3.3	20230	330	3	2	-	-			
1077	1.6	106200	2.9	20230	330	3	2	-	-			
1220	1.4	106200	2.5	20230	340	3	2	-	-			
1390	1.2	106200	2.2	20230	350	3	2	-	-			
1606	1.1	106200	1.9	20230	350	3	2	-	-			
1784	0.95	106200	1.7	20230	360	3	2	-	-			
2038	0.83	106200	1.5	20230	330	3	2	-	-			
2357	0.72	106200	1.3	20230	340	3	2	-	-			
2672	0.64	106200	1.2	20230	340	3	2	-	-			
3031	0.56	106200	1.0	20230	370	3	3	-	-		F127R77	AD2
3454	0.49	106200	0.91	20230	380	3	3	-	-			
3926	0.43	106200	0.80	20230	380	3	3	-	-			
4533	0.38	106200	0.69	20230	380	3	3	-	-			
5153	0.33	106200	0.61	20230	380	3	3	-	-			
5925	0.29	106200	0.53	20230	380	3	3	-	-			
6715	0.25	106200	0.47	20230	380	3	3	-	-			
7643	0.22	106200	0.41	20230	390	3	3	-	-			
8831	0.19	106200	0.36	20230	390	3	3	-	-			
10191	0.17	106200	0.31	20230	390	3	3	-	-			
11656	0.15	106200	0.27	20230	390	3	3	-	-			
12912	0.13	106200	0.24	20230	390	3	3	-	-			
14722	0.12	106200	0.21	20230	390	3	3	-	-			
16656	0.1	106200	0.19	20230	390	3	3	-	-			
19048	0.09	106200	0.16	20230	390	3	3	-	-			
22323	0.08	106200	0.14	20230	390	3	3	-	-			
24478	0.07	106200	0.13	20230	390	3	3	-	-			
376	4.5	106200	8.2	20230	440	3	2	-	-			
428	4	106200	7.2	20230	440	3	2	-	-			
495	3.4	106200	6.2	20230	470	3	2	-	-			
549	3.1	106200	5.6	20230	470	3	2	-	-			
648	2.6	106200	4.8	20230	490	3	2	-	-			
727	2.3	106200	4.2	20230	530	3	2	-	-			
820	2.1	106200	3.8	20230	540	3	2	-	-			
930	1.8	106200	3.3	20230	540	3	2	-	-			
1077	1.6	106200	2.9	20230	540	3	2	-	-			
1220	1.4	106200	2.5	20230	560	3	2	-	-			
1390	1.2	106200	2.2	20230	560	3	2	-	-			
1606	1.1	106200	1.9	20230	570	3	2	-	-		F127R77	AD3
1784	0.95	106200	1.7	20230	570	3	2	-	-			
2038	0.83	106200	1.5	20230	570	3	2	-	-			
2357	0.72	106200	1.3	20230	580	3	2	-	-			
2672	0.64	106200	1.2	20230	570	3	2	-	-			
3031	0.56	106200	1.0	20230	590	3	3	-	-			
3454	0.49	106200	0.91	20230	590	3	3	-	-			
3926	0.43	106200	0.80	20230	590	3	3	-	-			
4533	0.38	106200	0.69	20230	590	3	3	-	-			
5153	0.33	106200	0.61	20230	590	3	3	-	-			
5925	0.29	106200	0.53	20230	590	3	3	-	-			
6715	0.25	106200	0.47	20230	600	3	3	-	-			

9 F - theSnuggler® Helical

F.. AD

F127R77 AD.. , $n_e = 1700$ rpm



106200 lb-in

i [ratio]	n_a [rpm]	T_a max [lb-in]	P_e [HP]	$F_{Ra}^{1)}$ [lb]	F_{Re} [lb]	Stages		ϕ (/R) [']		
						Lg	Sm			
7643	0.22	106200	0.41	20230	600	3	3	-	-	F127R77
8831	0.19	106200	0.36	20230	600	3	3	-	-	
10191	0.17	106200	0.31	20230	600	3	3	-	-	
11656	0.15	106200	0.27	20230	600	3	3	-	-	
12912	0.13	106200	0.24	20230	600	3	3	-	-	
376	4.5	106200	8.2	20230	830	3	2	-	-	F127R77
428	4	106200	7.2	20230	840	3	2	-	-	
495	3.4	106200	6.2	20230	860	3	2	-	-	
549	3.1	106200	5.6	20230	870	3	2	-	-	
648	2.6	106200	4.8	20230	890	3	2	-	-	
727	2.3	106200	4.2	20230	920	3	2	-	-	
820	2.1	106200	3.8	20230	920	3	2	-	-	
930	1.8	106200	3.3	20230	920	3	2	-	-	
1077	1.6	106200	2.9	20230	930	3	2	-	-	
1220	1.4	106200	2.5	20230	940	3	2	-	-	
1390	1.2	106200	2.2	20230	940	3	2	-	-	
1606	1.1	106200	1.9	20230	950	3	2	-	-	
1784	0.95	106200	1.7	20230	950	3	2	-	-	
2038	0.83	106200	1.5	20230	950	3	2	-	-	
2357	0.72	106200	1.3	20230	960	3	2	-	-	
3031	0.56	106200	1.0	20230	960	3	3	-	-	
3454	0.49	106200	0.91	20230	970	3	3	-	-	
4533	0.38	106200	0.69	20230	970	3	3	-	-	
7643	0.22	106200	0.41	20230	980	3	3	-	-	
8831	0.19	106200	0.36	20230	980	3	3	-	-	



Weight [lbs]	Stages		AD2	AD3	AD4
	Large	Small			
F127R77	3	2	1012	1019	1033
	3	3	1014	1022	1035

FA127: -80 lb / FAF127: +2 lbs / FF127: +98 lbs



9.2.18 F127R87

F127R87 AD.. , n _e = 1700 rpm										106200 lb-in		
i [ratio]	n _a [rpm]	T _{a max} [lb-in]	P _e [HP]	F _{Ra} ¹⁾ [lb]	F _{Re} [lb]	Stages		φ _(/R) [']				
						Lg	Sm					
293	5.8	106200	10.5	20230	240	3	2	-	-			
312	5.4	106200	9.9	20230	230	3	2	-	-			
374	4.5	106200	8.3	20230	260	3	2	-	-		F127R87	AD2
418	4.1	106200	7.4	20230	270	3	2	-	-			
483	3.5	106200	6.4	20230	300	3	2	-	-			
166	10	106200	18.6	20230	320	3	2	-	-			
198	8.6	106200	15.6	20230	360	3	2	-	-			
223	7.6	106200	13.9	20230	390	3	2	-	-			
259	6.6	106200	11.9	20230	420	3	2	-	-			
293	5.8	106200	10.5	20230	440	3	2	-	-		F127R87	AD3
312	5.4	106200	9.9	20230	430	3	2	-	-			
374	4.5	106200	8.3	20230	460	3	2	-	-			
418	4.1	106200	7.4	20230	460	3	2	-	-			
483	3.5	106200	6.4	20230	490	3	2	-	-			
166	10	106200	18.6	20230	750	3	2	-	-			
198	8.6	106200	15.6	20230	790	3	2	-	-			
223	7.6	106200	13.9	20230	810	3	2	-	-			
259	6.6	106200	11.9	20230	830	3	2	-	-			
293	5.8	106200	10.5	20230	850	3	2	-	-		F127R87	AD4
312	5.4	106200	9.9	20230	850	3	2	-	-			
374	4.5	106200	8.3	20230	870	3	2	-	-			
418	4.1	106200	7.4	20230	880	3	2	-	-			
483	3.5	106200	6.4	20230	900	3	2	-	-			
166	10	106200	18.6	20230	1420	3	2	-	-			
198	8.6	106200	15.6	20230	1460	3	2	-	-			
223	7.6	106200	13.9	20230	1480	3	2	-	-			
259	6.6	106200	11.9	20230	1500	3	2	-	-			
293	5.8	106200	10.5	20230	1520	3	2	-	-		F127R87	AD5
312	5.4	106200	9.9	20230	1510	3	2	-	-			
374	4.5	106200	8.3	20230	1540	3	2	-	-			
418	4.1	106200	7.4	20230	1540	3	2	-	-			
483	3.5	106200	6.4	20230	1570	3	2	-	-			
Weight [lbs]			Stages		AD2	AD3	AD4	AD5				
			Large	Small								
F127R87			3	2	1057	1066	1079	1112				
FA127: -80 lb / FAF127: +2 lbs / FF127: +98 lbs												

9.2.19 F157

F157 AD.. , n _e = 1700 rpm										159300 lb-in		
i [ratio]	n _a [rpm]	T _a max [lb-in]	P _e [HP]	F _{Ra} ¹⁾ [lb]	F _{Re} [lb]	Stages		φ (°/R) [']			F157	AD5
						Lg	Sm					
60.25	28	159300	75	17040	690	3	-	5	M2,5-6			
68.28	25	159300	66	18000	750	3	-	5	-			
78.46	22	159300	57	19110	810	3	-	5	-			
85.80	20	159300	52	19850	850	3	-	5	-			
96.53	18	159300	47	20860	1190	3	-	5	M2			
108.49	16	159300	41	21890	1210	3	-	5	-			
125.14	14	159300	36	22540	1230	3	-	5	-			
141.80	12	159300	32	22540	1240	3	-	5	-			
162.96	10	159300	28	22540	1260	3	-	5	-			
178.20	9.5	159300	25	22540	1270	3	-	5	-			
217.62	7.8	159300	21	22540	1290	3	-	5	-			
267.43	6.4	159300	16.8	22540	1310	3	-	5	-			
35.75	48	97350	76	16540	900	2	-	4	-			
43.94	39	88500	56	18360	1250	2	-	4	-			
52.24	33	159300	86	15990	1380	3	-	5	M1-6			
60.25	28	159300	75	17040	1410	3	-	5	M2,5-6			
68.28	25	159300	66	18000	1440	3	-	5	-			
78.46	22	159300	57	19110	1470	3	-	5	-			
85.80	20	159300	52	19850	1490	3	-	5	-			
96.53	18	159300	47	20860	1790	3	-	5	M2			
108.49	16	159300	41	21890	1810	3	-	5	-			
125.14	14	159300	36	22540	1830	3	-	5	-			
141.80	12	159300	32	22540	1850	3	-	5	-			
162.96	10	159300	28	22540	1860	3	-	5	-			
178.20	9.5	159300	25	22540	1870	3	-	5	-			
217.62	7.8	159300	21	22540	1890	3	-	5	-			
32.55	52	159300	138	12810	3090	3	-	5	M1-6			
35.75	48	97350	76	16540	2660	2	-	4	-			
40.06	42	159300	112	14150	3460	3	-	5	M1-6			
46.48	37	159300	97	15160	3500	3	-	5	M1-6			
52.24	33	159300	86	15990	3530	3	-	5	M1-6			
60.25	28	159300	75	17040	3570	3	-	5	M2,5-6			
68.28	25	159300	66	18000	3590	3	-	5	-			
78.46	22	159300	57	19110	3620	3	-	5	-			
85.80	20	159300	52	19850	3640	3	-	5	-			
96.53	18	159300	47	20860	3890	3	-	5	M2			
108.49	16	159300	41	21890	3910	3	-	5	-			
125.14	14	159300	36	22540	3920	3	-	5	-			
141.80	12	159300	32	22540	3940	3	-	5	-			
162.96	10	159300	28	22540	3950	3	-	5	-			
178.20	9.5	159300	25	22540	3960	3	-	5	-			



F157 AD.. , n_e = 1700 rpm 159300 lb-in

i [ratio]	n _a [rpm]	T _{a max} [lb-in]	P _e [HP]	F _{Ra} ¹⁾ [lb]	F _{Re} [lb]	Stages		φ (°/R) [']		
						Lg	Sm			
11.92	143	141600	330	8270	4430	2	-	5	M1-6	F157 AD8
13.96	122	150450	300	8570	4460	2	-	5	M1-6	
16.85	101	159300	263	9060	4490	2	-	5	M1-6	
19.77	86	150450	212	10350	4700	2	-	4	M1-6	
22.16	77	159300	200	10530	4670	2	-	4	M1-6	
25.43	67	132750	145	12660	5010	2	-	4	M1-6	
27.60	62	159300	163	11800	5420	3	-	5	M1-6	
28.60	59	150450	146	12460	4870	2	-	4	M1-6	
32.55	52	159300	138	12810	5490	3	-	5	M1-6	
40.06	42	159300	112	14150	5580	3	-	5	M1-6	
46.48	37	159300	97	15160	5610	3	-	5	M1-6	
52.24	33	159300	86	15990	5640	3	-	5	M1-6	
60.25	28	159300	75	17040	5680	3	-	5	M2,5-6	
68.28	25	159300	66	18000	5700	3	-	5	-	
96.53	18	159300	47	20860	6020	3	-	5	M2	
108.49	16	159300	41	21890	6030	3	-	5	-	



Weight [lbs]	Stages		AD5	AD6	AD7	AD8
	Large	Small				
F157	2	-	1489	1527	1513	1565
	3	-	1503	1540	1527	1578

FA157: -46 lb / FAF157: +84 lbs / FF157: +236 lbs

9.2.20 F157R97

F157R97 AD.. , n _e = 1700 rpm										159300 lb-in		
i [ratio]	n _a [rpm]	T _a max [lb-in]	P _e [HP]	F _{Ra} ¹⁾ [lb]	F _{Re} [lb]	Stages		φ (/R) [']				
						Lg	Sm					
273	6.2	159300	17.0	22540	310	3	2	-	-			
302	5.6	159300	15.3	22540	320	3	2	-	-			
353	4.8	159300	13.1	22540	410	3	2	-	-			
446	3.8	159300	10.4	22540	410	3	2	-	-			
503	3.4	159300	9.2	22540	460	3	2	-	-			
576	3.0	159300	8.0	22540	470	3	2	-	-			
680	2.5	159300	6.8	22540	480	3	2	-	-			
764	2.2	159300	6.1	22540	490	3	2	-	-			
845	2.0	159300	5.5	22540	490	3	2	-	-			
953	1.8	159300	4.9	22540	490	3	2	-	-			
1169	1.5	159300	4.0	22540	500	3	2	-	-			
1308	1.3	159300	3.5	22540	500	3	2	-	-			
1441	1.2	159300	3.3	22540	540	3	3	-	-			
1674	1.0	159300	2.8	22540	510	3	2	-	-			
1944	0.87	159300	2.4	22540	540	3	2	-	-			
2185	0.78	159300	2.1	22540	540	3	2	-	-			
2427	0.70	159300	1.9	22540	540	3	2	-	-			
2780	0.61	159300	1.7	22540	550	3	3	-	-		F157R97	AD3
3210	0.53	159300	1.5	22540	560	3	3	-	-			
3607	0.47	159300	1.3	22540	560	3	3	-	-			
4130	0.41	159300	1.1	22540	560	3	3	-	-			
4831	0.35	159300	0.97	22540	570	3	3	-	-			
5404	0.31	159300	0.87	22540	570	3	3	-	-			
6295	0.27	159300	0.75	22540	570	3	3	-	-			
7075	0.24	159300	0.66	22540	570	3	3	-	-			
8026	0.21	159300	0.59	22540	570	3	3	-	-			
9021	0.19	159300	0.52	22540	580	3	3	-	-			
10033	0.17	159300	0.47	22540	580	3	3	-	-			
12235	0.14	159300	0.38	22540	580	3	3	-	-			
13751	0.12	159300	0.34	22540	580	3	3	-	-			
16358	0.10	159300	0.29	22540	580	3	3	-	-			
17984	0.09	159300	0.26	22540	580	3	3	-	-			
20212	0.08	159300	0.23	22540	580	3	3	-	-			
23464	0.07	159300	0.20	22540	580	3	3	-	-			
197	8.6	159300	24	22540	680	3	2	-	-			
202	8.4	159300	23	22540	710	3	2	-	-			
232	7.3	159300	20	22540	730	3	2	-	-			
273	6.2	159300	17.0	22540	740	3	2	-	-			
302	5.6	159300	15.3	22540	750	3	2	-	-			
353	4.8	159300	13.1	22540	830	3	2	-	-			
446	3.8	159300	10.4	22540	830	3	2	-	-			
503	3.4	159300	9.2	22540	870	3	2	-	-			
576	3.0	159300	8.0	22540	880	3	2	-	-			
680	2.5	159300	6.8	22540	890	3	2	-	-			
764	2.2	159300	6.1	22540	900	3	2	-	-			
845	2.0	159300	5.5	22540	900	3	2	-	-			
953	1.8	159300	4.9	22540	900	3	2	-	-			
1169	1.5	159300	4.0	22540	910	3	2	-	-		F157R97	AD4
1308	1.3	159300	3.5	22540	910	3	2	-	-			
1441	1.2	159300	3.3	22540	940	3	3	-	-			
1674	1.0	159300	2.8	22540	920	3	2	-	-			
1944	0.87	159300	2.4	22540	940	3	2	-	-			
2185	0.78	159300	2.1	22540	950	3	2	-	-			
2427	0.70	159300	1.9	22540	950	3	2	-	-			
2780	0.61	159300	1.7	22540	950	3	3	-	-			
3210	0.53	159300	1.5	22540	960	3	3	-	-			
3607	0.47	159300	1.3	22540	970	3	3	-	-			
4130	0.41	159300	1.1	22540	970	3	3	-	-			
4831	0.35	159300	0.97	22540	970	3	3	-	-			
5404	0.31	159300	0.87	22540	970	3	3	-	-			

F157R97 AD.. , n_e = 1700 rpm 159300 lb-in

i [ratio]	n _a [rpm]	T _{a max} [lb-in]	P _e [HP]	F _{Ra} ¹⁾ [lb]	F _{Re} [lb]	Stages		φ (/R) [']		
						Lg	Sm			
6295	0.27	159300	0.75	22540	970	3	3	-	-	F157R97
7075	0.24	159300	0.66	22540	970	3	3	-	-	
8026	0.21	159300	0.59	22540	970	3	3	-	-	
9021	0.19	159300	0.52	22540	980	3	3	-	-	
10033	0.17	159300	0.47	22540	980	3	3	-	-	
12235	0.14	159300	0.38	22540	980	3	3	-	-	
13751	0.12	159300	0.34	22540	980	3	3	-	-	
16358	0.10	159300	0.29	22540	980	3	3	-	-	
197	8.6	159300	24	22540	1350	3	2	-	-	F157R97
202	8.4	159300	23	22540	1380	3	2	-	-	
232	7.3	159300	20	22540	1400	3	2	-	-	
273	6.2	159300	17.0	22540	1410	3	2	-	-	
302	5.6	159300	15.3	22540	1420	3	2	-	-	
353	4.8	159300	13.1	22540	1500	3	2	-	-	
446	3.8	159300	10.4	22540	1490	3	2	-	-	
503	3.4	159300	9.2	22540	1540	3	2	-	-	
576	3.0	159300	8.0	22540	1550	3	2	-	-	
680	2.5	159300	6.8	22540	1550	3	2	-	-	
764	2.2	159300	6.1	22540	1560	3	2	-	-	
845	2.0	159300	5.5	22540	1570	3	2	-	-	
953	1.8	159300	4.9	22540	1570	3	2	-	-	
1169	1.5	159300	4.0	22540	1570	3	2	-	-	
1308	1.3	159300	3.5	22540	1580	3	2	-	-	
1441	1.2	159300	3.3	22540	1610	3	3	-	-	
1944	0.87	159300	2.4	22540	1610	3	2	-	-	
2185	0.78	159300	2.1	22540	1610	3	2	-	-	
2427	0.70	159300	1.9	22540	1610	3	2	-	-	
2780	0.61	159300	1.7	22540	1620	3	3	-	-	
3210	0.53	159300	1.5	22540	1630	3	3	-	-	
3607	0.47	159300	1.3	22540	1630	3	3	-	-	
4130	0.41	159300	1.1	22540	1630	3	3	-	-	
4831	0.35	159300	0.97	22540	1630	3	3	-	-	
5404	0.31	159300	0.87	22540	1630	3	3	-	-	
8026	0.21	159300	0.59	22540	1640	3	3	-	-	
9021	0.19	159300	0.52	22540	1640	3	3	-	-	
10033	0.17	159300	0.47	22540	1640	3	3	-	-	
197	8.6	159300	24	22540	1950	3	2	-	-	F157R97
202	8.4	159300	23	22540	1980	3	2	-	-	
232	7.3	159300	20	22540	1990	3	2	-	-	
273	6.2	159300	17.0	22540	2000	3	2	-	-	
302	5.6	159300	15.3	22540	2010	3	2	-	-	
353	4.8	159300	13.1	22540	2080	3	2	-	-	
446	3.8	159300	10.4	22540	2080	3	2	-	-	
503	3.4	159300	9.2	22540	2120	3	2	-	-	
576	3.0	159300	8.0	22540	2130	3	2	-	-	
680	2.5	159300	6.8	22540	2130	3	2	-	-	
764	2.2	159300	6.1	22540	2140	3	2	-	-	
845	2.0	159300	5.5	22540	2150	3	2	-	-	
953	1.8	159300	4.9	22540	2150	3	2	-	-	
1441	1.2	159300	3.3	22540	2180	3	3	-	-	
1944	0.87	159300	2.4	22540	2180	3	2	-	-	
2185	0.78	159300	2.1	22540	2190	3	2	-	-	
3210	0.53	159300	1.5	22540	2200	3	3	-	-	
3607	0.47	159300	1.3	22540	2210	3	3	-	-	
4130	0.41	159300	1.1	22540	2210	3	3	-	-	
4831	0.35	159300	0.97	22540	2210	3	3	-	-	
8026	0.21	159300	0.59	22540	2210	3	3	-	-	
9021	0.19	159300	0.52	22540	2210	3	3	-	-	
10033	0.17	159300	0.47	22540	2220	3	3	-	-	

Weight [lbs]	Stages		AD3	AD4	AD5	AD6
	Large	Small				
F157R97	3	2	1727	1738	1775	1805
	3	3	1734	1745	1782	1812

FA157: -46 lb / FAF157: +84 lbs / FF157: +236 lbs

9 F - theSnuggler® Helical

F.. AM.. [NEMA dimensions]

FA27..

42 006 00 11

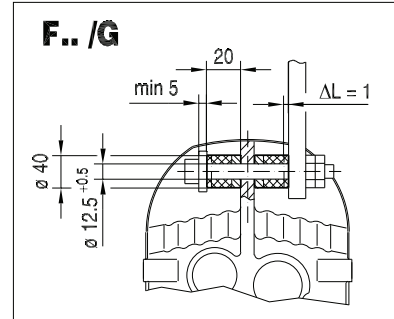
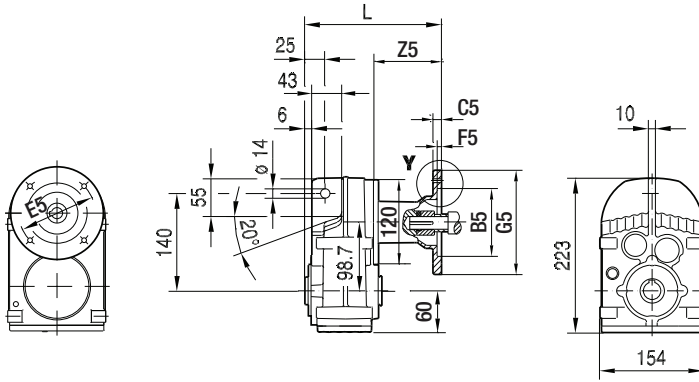

FA27..

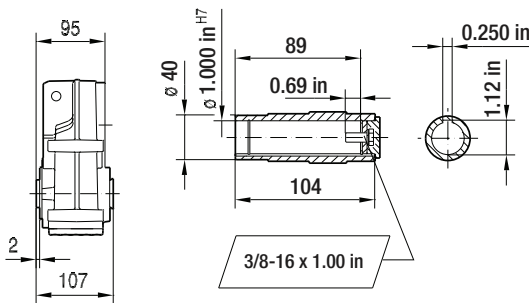

FV27..

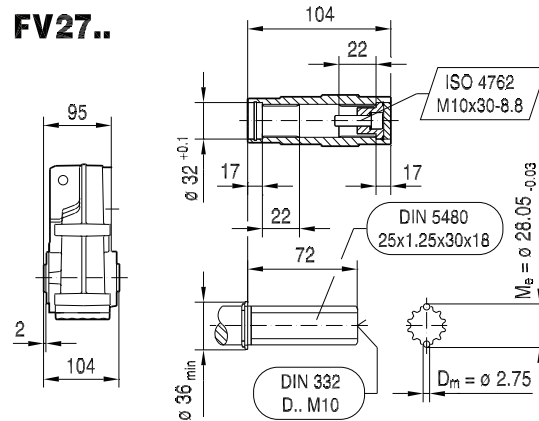

FH27..

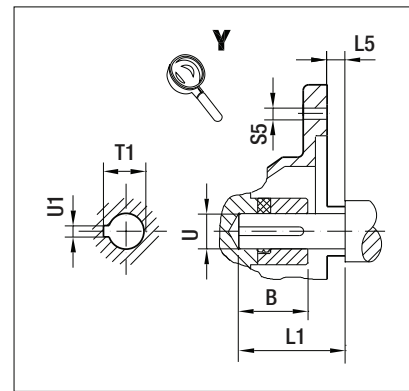
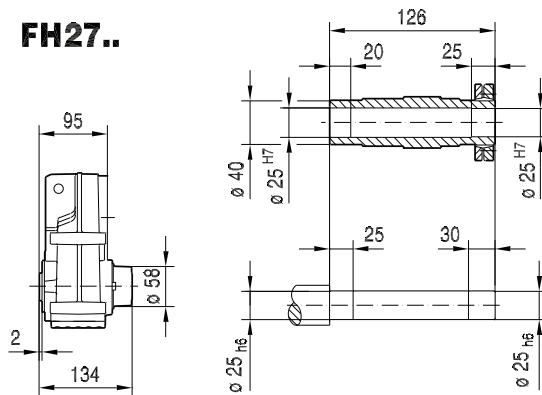

(→ 132)	B	B5	C5	E5	F5	G5	L	L1	L5	S5	T1	U	U1	Z5
AM56	1.23 in	4.50 in	11	5.875 in	4.5	170	189	1.88 in	-0.18 in	10.5	0.71 in	0.625 in	0.188 in	93.5
AM143	1.68 in	4.50 in	12	5.875 in	4.5	170	212	2.25 in	0.13 in	10.5	0.98 in	0.875 in	0.188 in	117
AM145	1.68 in	4.50 in	12	5.875 in	4.5	170	212	2.25 in	0.13 in	10.5	0.98 in	0.875 in	0.188 in	117

Dimensions in mm unless otherwise noted. For all available output shaft diameters, see page 411.

9 F - theSnuggler® Helical

F.. AM.. [NEMA dimensions]

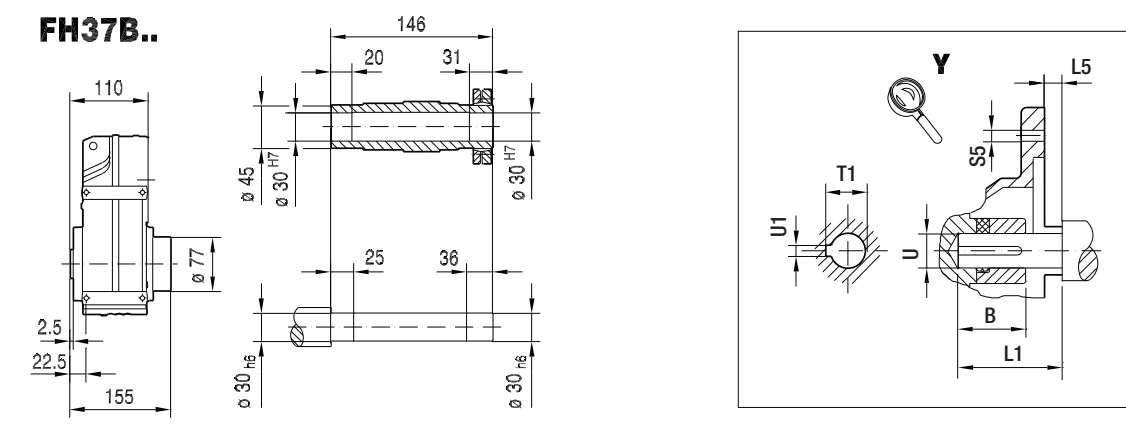
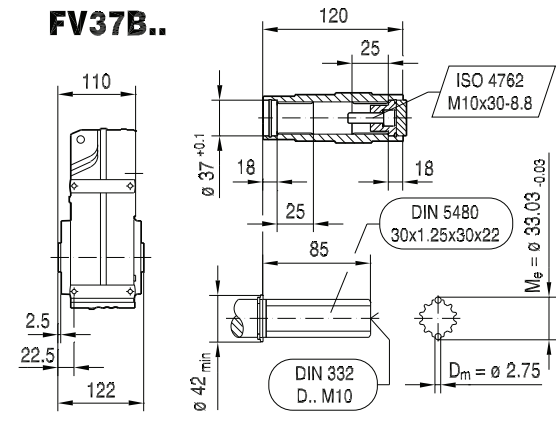
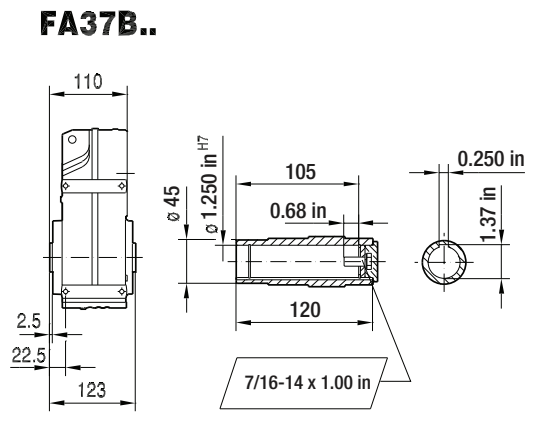
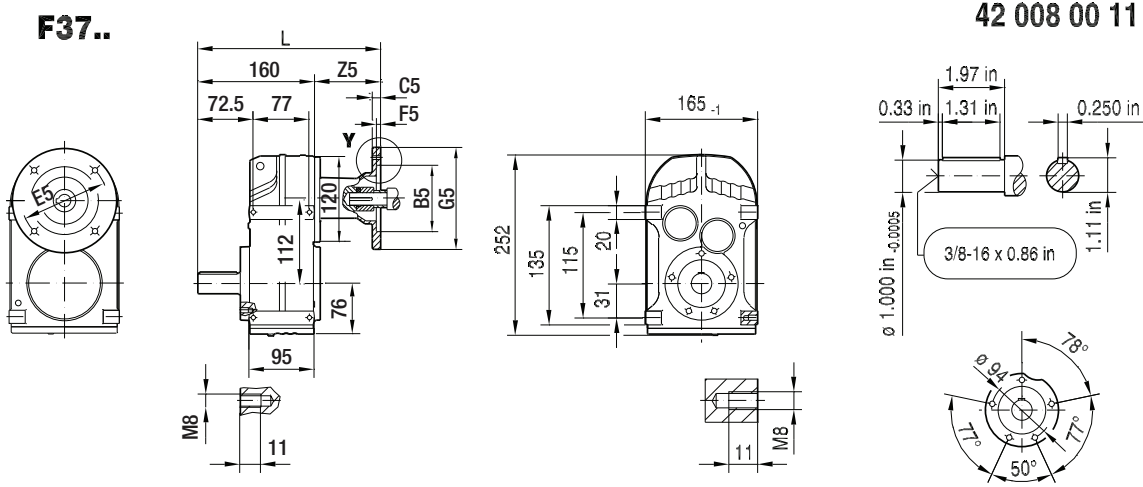

(→ 132)	B	B5	C5	E5	F5	G5	L	L1	L5	S5	T1	U	U1	Z5
AM56	1.23 in	4.50 in	11	5.875 in	4.5	170	254	1.88 in	-0.18 in	10.5	0.71 in	0.625 in	0.188 in	93.5
AM143	1.68 in	4.50 in	12	5.875 in	4.5	170	277	2.25 in	0.13 in	10.5	0.98 in	0.875 in	0.188 in	117
AM145	1.68 in	4.50 in	12	5.875 in	4.5	170	277	2.25 in	0.13 in	10.5	0.98 in	0.875 in	0.188 in	117

Dimensions in mm unless otherwise noted. For all available output shaft diameters, see page 409.

FF37..

42 009 00 11

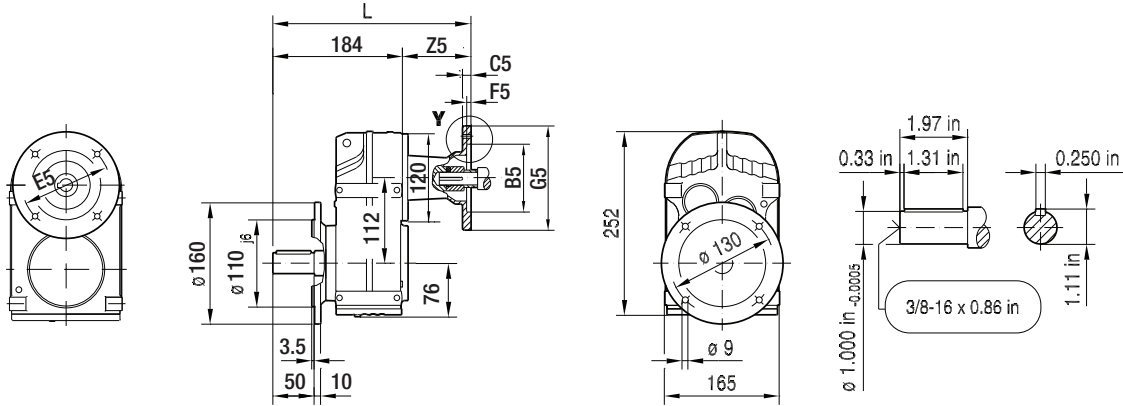

FAF37..

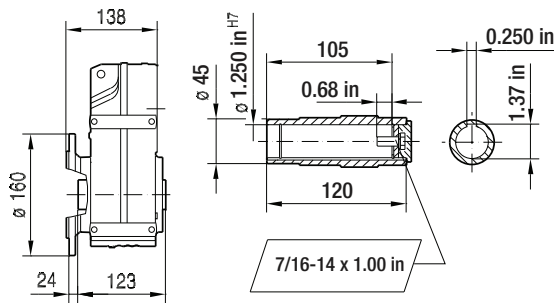

FVF37..

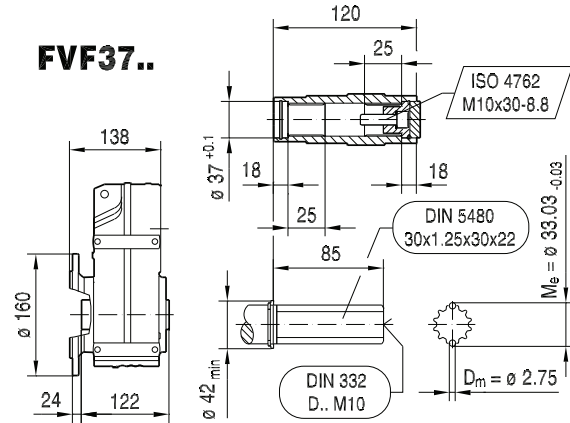

FHF37..

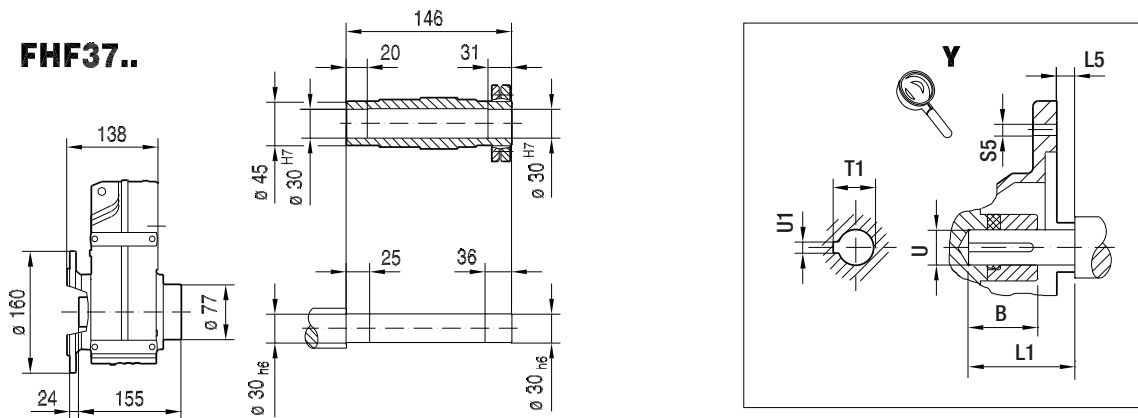

(→ 132)	B	B5	C5	E5	F5	G5	L	L1	L5	S5	T1	U	U1	Z5
AM56	1.23 in	4.50 in	11	5.875 in	4.5	170	278	1.88 in	-0.18 in	10.5	0.71 in	0.625 in	0.188 in	93.5
AM143	1.68 in	4.50 in	12	5.875 in	4.5	170	301	2.25 in	0.13 in	10.5	0.98 in	0.875 in	0.188 in	117
AM145	1.68 in	4.50 in	12	5.875 in	4.5	170	301	2.25 in	0.13 in	10.5	0.98 in	0.875 in	0.188 in	117

Dimensions in mm unless otherwise noted. For all available output shaft diameters, see page 409.

FAZ37..

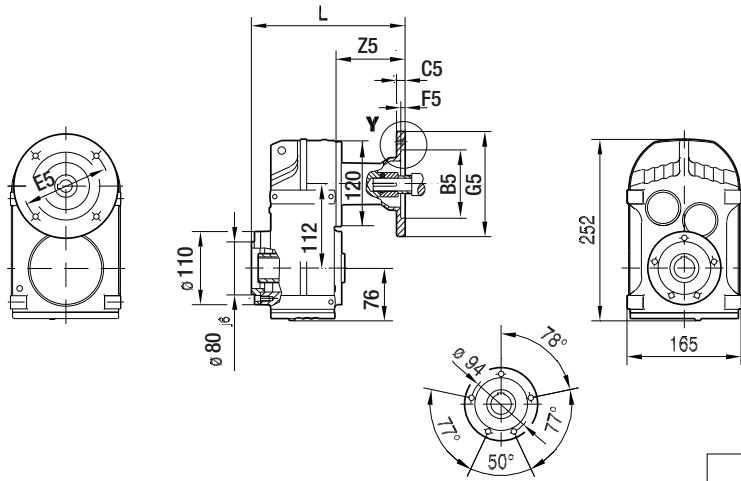

42 011 00 11

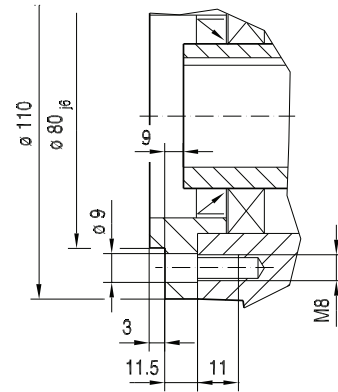

FAZ37..

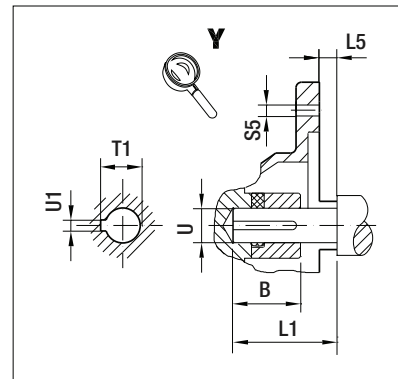
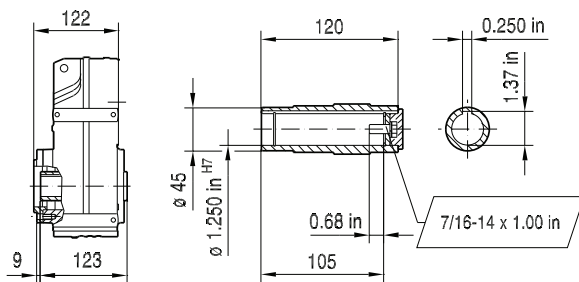

FHZ37..

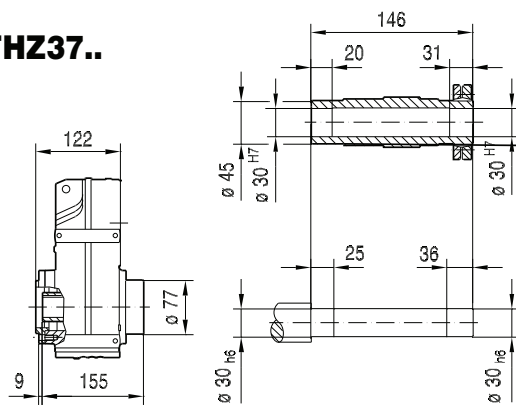

FVZ37..

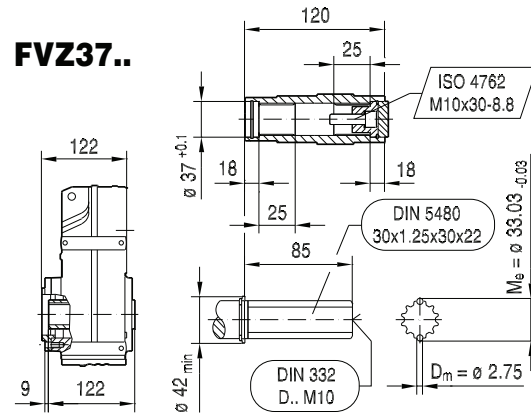

(→ 132)	B	B5	C5	E5	F5	G5	L	L1	L5	S5	T1	U	U1	Z5
AM56	1.23 in	4.50 in	11	5.875 in	4.5	170	216	1.88 in	-0.18 in	10.5	0.71 in	0.625 in	0.188 in	93.5
AM143	1.68 in	4.50 in	12	5.875 in	4.5	170	239	2.25 in	0.13 in	10.5	0.98 in	0.875 in	0.188 in	117
AM145	1.68 in	4.50 in	12	5.875 in	4.5	170	239	2.25 in	0.13 in	10.5	0.98 in	0.875 in	0.188 in	117

Dimensions in mm unless otherwise noted. For all available output shaft diameters, see page 411.

9 F - theSnuggler® Helical

F.. AM.. [NEMA dimensions]

FT37..

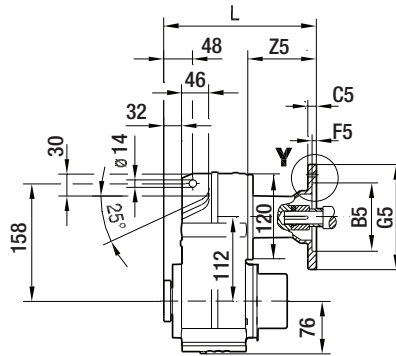
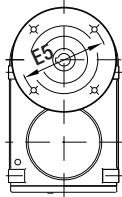

42 012 00 11

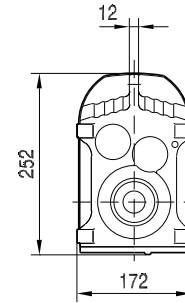

NON-Symmetrical FT37..

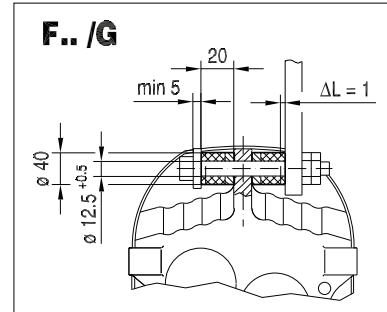
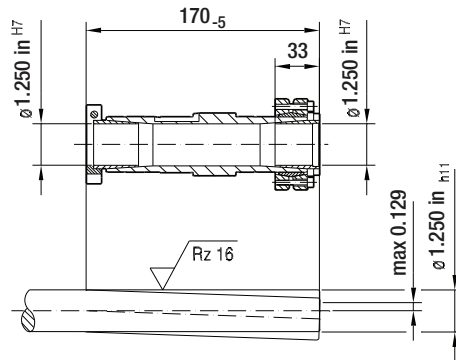
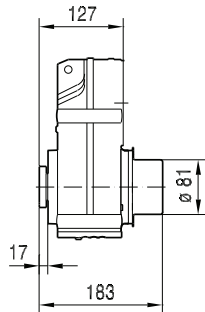

Symmetrical FT37..

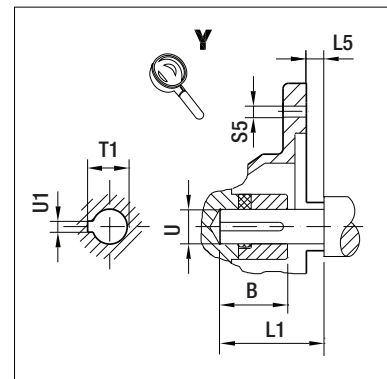
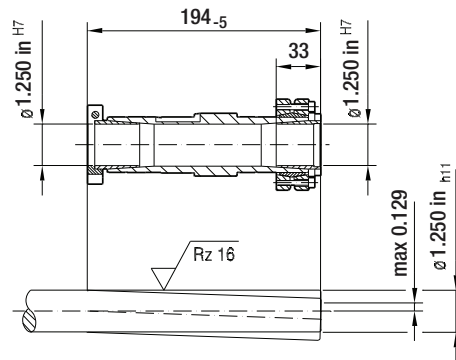
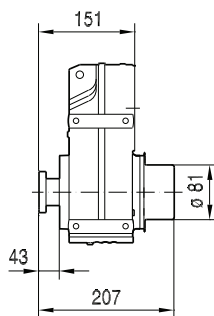

(→ 132)	B	B5	C5	E5	F5	G5	L	L1	L5	S5	T1	U	U1	Z5
AM56	1.23 in	4.50 in	11	5.875 in	4.5	170	221	1.88 in	-0.18 in	10.5	0.71 in	0.625 in	0.188 in	93.5
AM143	1.68 in	4.50 in	12	5.875 in	4.5	170	244	2.25 in	0.13 in	10.5	0.98 in	0.875 in	0.188 in	117
AM145	1.68 in	4.50 in	12	5.875 in	4.5	170	244	2.25 in	0.13 in	10.5	0.98 in	0.875 in	0.188 in	117

Dimensions in mm unless otherwise noted. For all available output shaft diameters, see page 413.

F47..

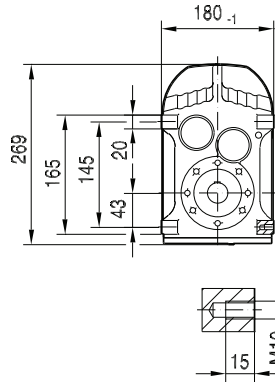
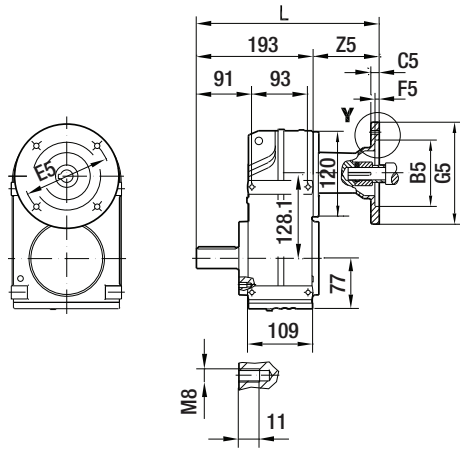

42 013 00 11

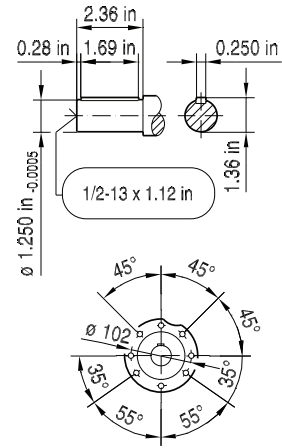

FA47B..

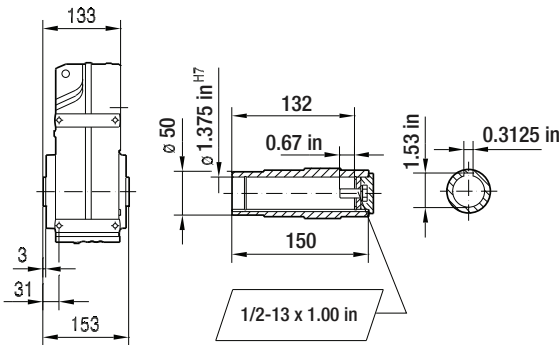

FV47B..

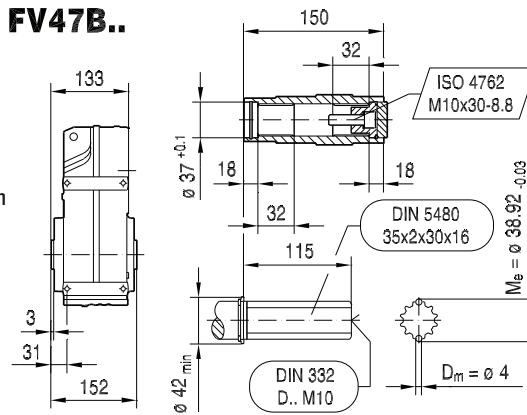

FH47B..

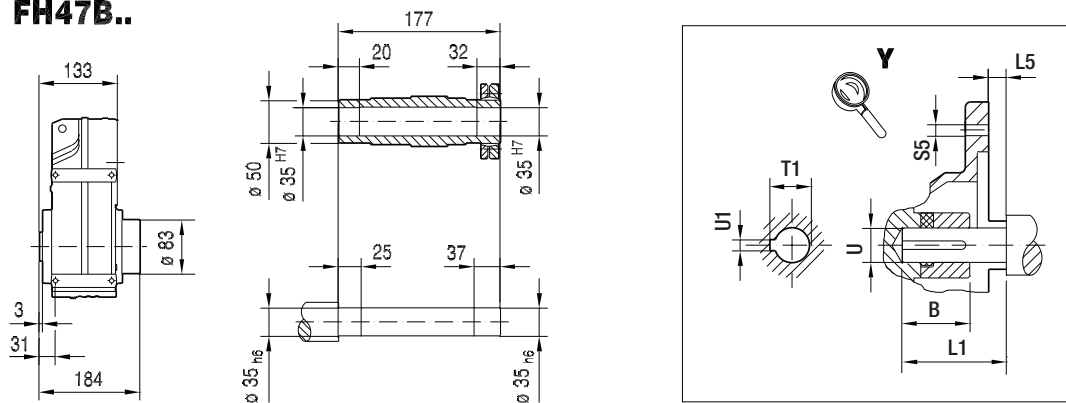

(→ 132)	B	B5	C5	E5	F5	G5	L	L1	L5	S5	T1	U	U1	Z5
AM56	1.23 in	4.50 in	11	5.875 in	4.5	170	287	1.88 in	-0.18 in	10.5	0.71 in	0.625 in	0.188 in	93.5
AM143	1.68 in	4.50 in	12	5.875 in	4.5	170	310	2.25 in	0.13 in	10.5	0.98 in	0.875 in	0.188 in	117
AM145	1.68 in	4.50 in	12	5.875 in	4.5	170	310	2.25 in	0.13 in	10.5	0.98 in	0.875 in	0.188 in	117

Note: Dimensions in mm unless otherwise noted. For all available output shaft diameters, see page 409. For dimensions of compound gear units (ex: F47R37) see page 401.

9 F - theSnuggler® Helical

F.. AM.. [NEMA dimensions]

FF47..

42 014 00 11

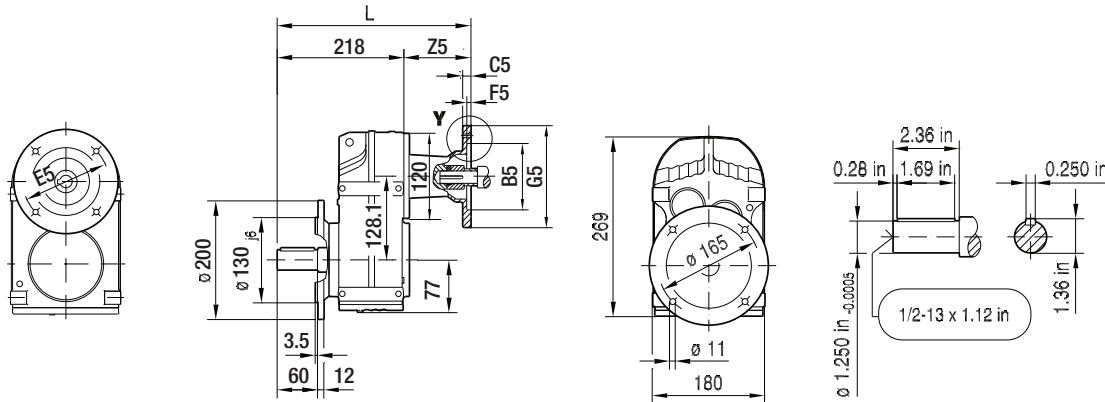

FAF47..

FVF47..

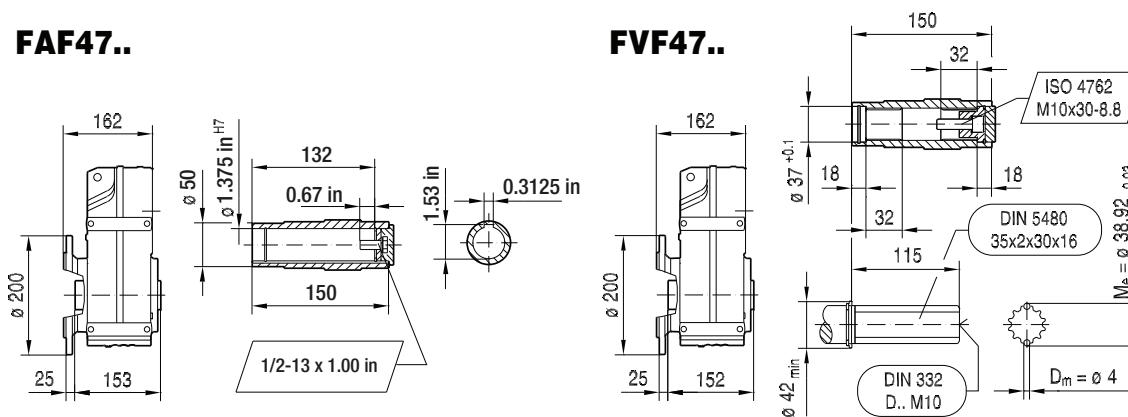

FHF47..

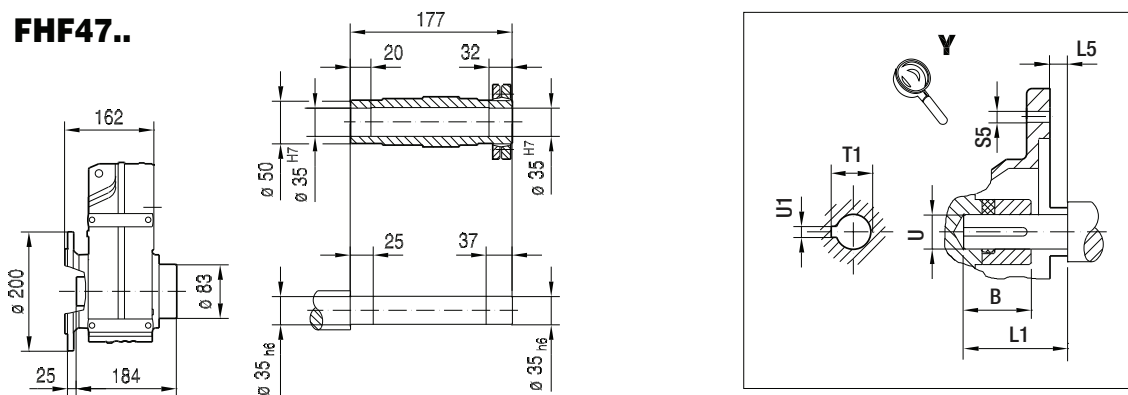

(→ 132)	B	B5	C5	E5	F5	G5	L	L1	L5	S5	T1	U	U1	Z5
AM56	1.23 in	4.50 in	11	5.875 in	4.5	170	312	1.88 in	-0.18 in	10.5	0.71 in	0.625 in	0.188 in	93.5
AM143	1.68 in	4.50 in	12	5.875 in	4.5	170	335	2.25 in	0.13 in	10.5	0.98 in	0.875 in	0.188 in	117
AM145	1.68 in	4.50 in	12	5.875 in	4.5	170	335	2.25 in	0.13 in	10.5	0.98 in	0.875 in	0.188 in	117

Note: Dimensions in mm unless otherwise noted. For all available output shaft diameters, see page 409. For dimensions of compound gear units (ex: FF47R37) see page 401.

FA47..

42 015 00 11

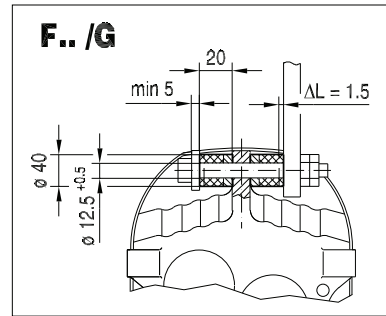
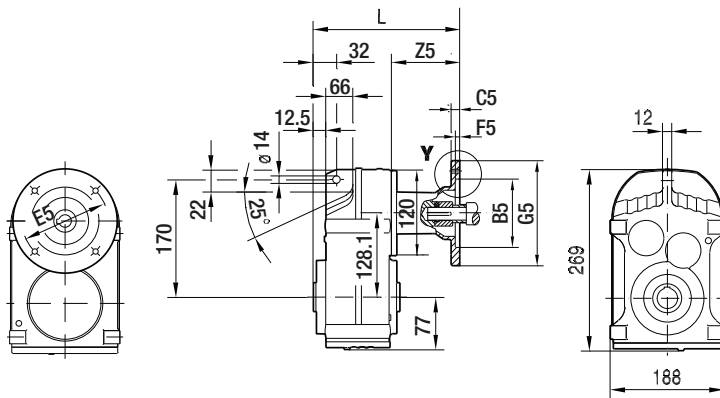

FA47..

FV47..

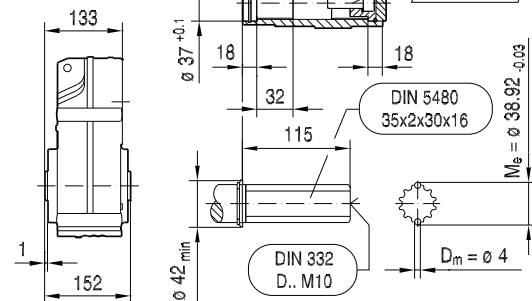
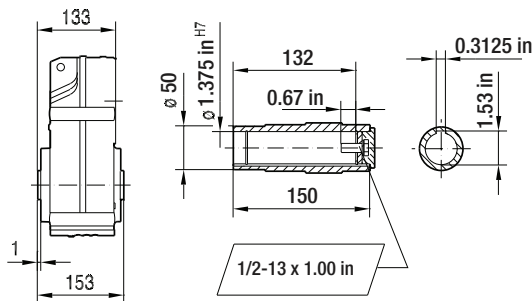

FH47..

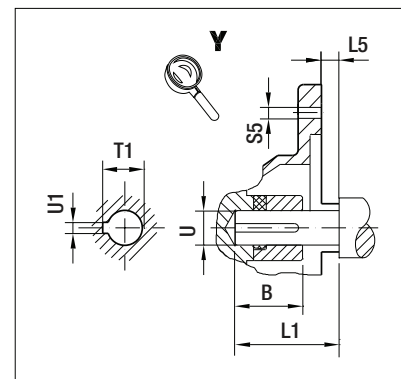

(→ 132)	B	B5	C5	E5	F5	G5	L	L1	L5	S5	T1	U	U1	Z5
AM56	1.23 in	4.50 in	11	5.875 in	4.5	170	227	1.88 in	-0.18 in	10.5	0.71 in	0.625 in	0.188 in	93.5
AM143	1.68 in	4.50 in	12	5.875 in	4.5	170	250	2.25 in	0.13 in	10.5	0.98 in	0.875 in	0.188 in	117
AM145	1.68 in	4.50 in	12	5.875 in	4.5	170	250	2.25 in	0.13 in	10.5	0.98 in	0.875 in	0.188 in	117

Note: Dimensions in mm unless otherwise noted. For all available output shaft diameters, see page 411. For dimensions of compound gear units (ex: FA47R37) see page 401.

9 F - theSnuggler® Helical

F.. AM.. [NEMA dimensions]

FAZ47..

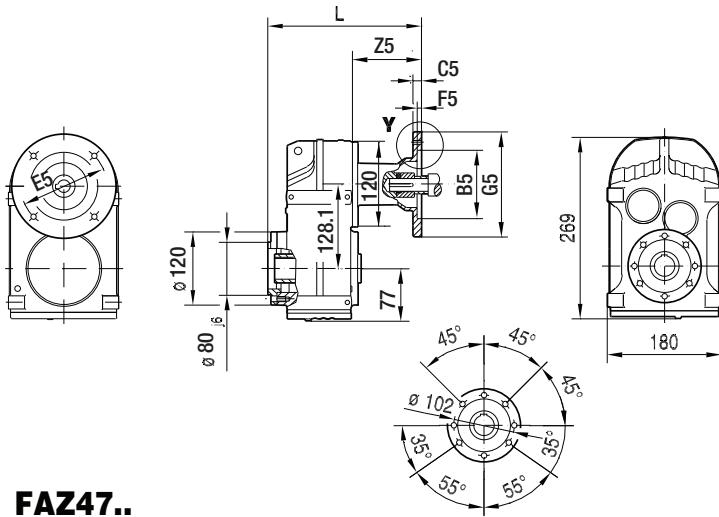

42 016 00 11

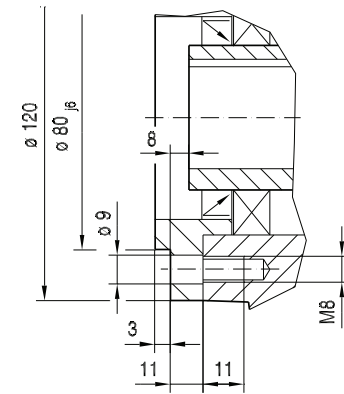

FAZ47..

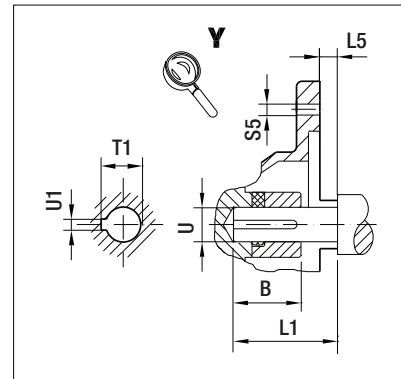
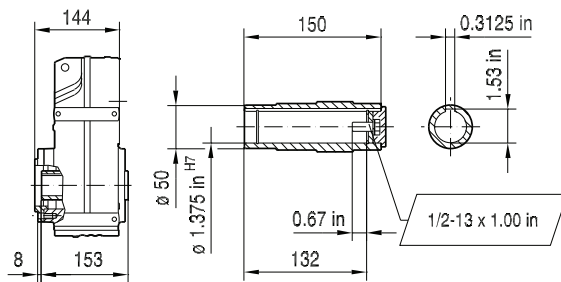

FHZ47..

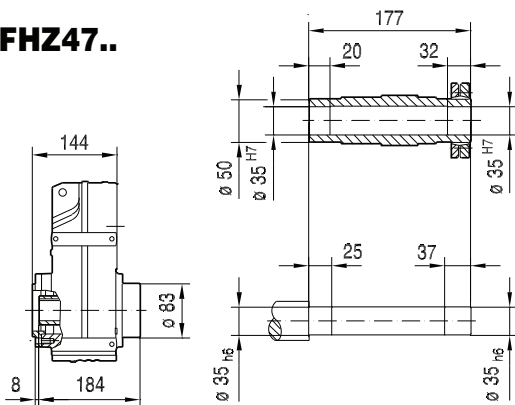

FVZ47..

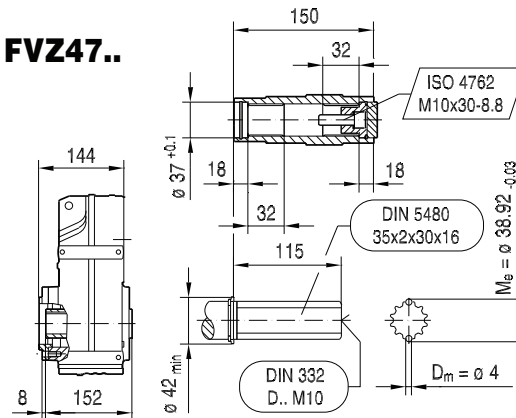

(→ 132)	B	B5	C5	E5	F5	G5	L	L1	L5	S5	T1	U	U1	Z5
AM56	1.23 in	4.50 in	11	5.875 in	4.5	170	238	1.88 in	-0.18 in	10.5	0.71 in	0.625 in	0.188 in	93.5
AM143	1.68 in	4.50 in	12	5.875 in	4.5	170	261	2.25 in	0.13 in	10.5	0.98 in	0.875 in	0.188 in	117
AM145	1.68 in	4.50 in	12	5.875 in	4.5	170	261	2.25 in	0.13 in	10.5	0.98 in	0.875 in	0.188 in	117

Note: Dimensions in mm unless otherwise noted. For all available output shaft diameters, see page 411. For dimensions of compound gear units (ex: FAZ47R37) see page 401.

FT47..

42 017 00 11

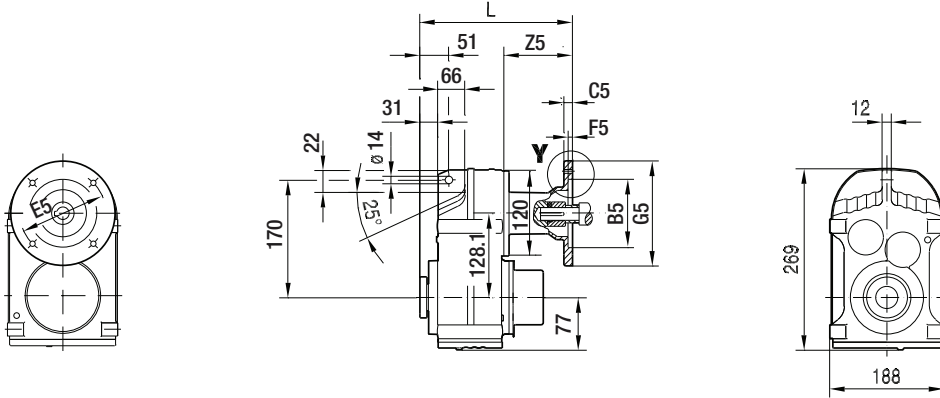

**NON-Symmetrical
FT47..**

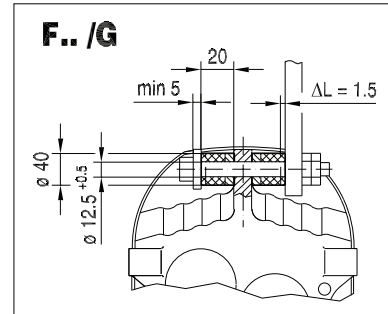
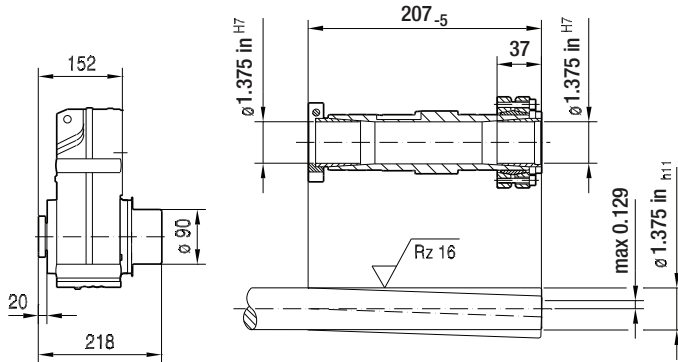

**Symmetrical
FT47..**

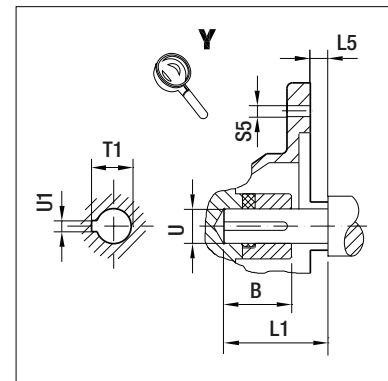
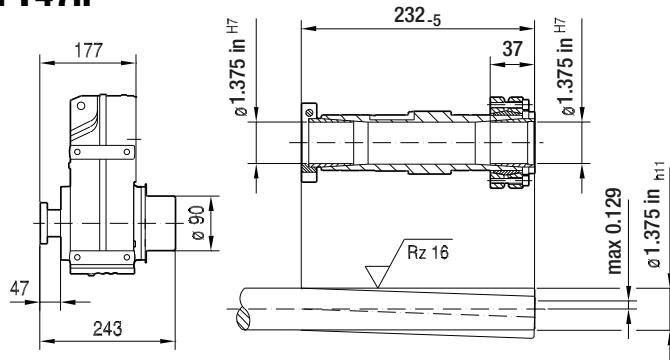

(→ 132)	B	B5	C5	E5	F5	G5	L	L1	L5	S5	T1	U	U1	Z5
AM56	1.23 in	4.50 in	11	5.875 in	4.5	170	246	1.88 in	-0.18 in	10.5	0.71 in	0.625 in	0.188 in	93.5
AM143	1.68 in	4.50 in	12	5.875 in	4.5	170	269	2.25 in	0.13 in	10.5	0.98 in	0.875 in	0.188 in	117
AM145	1.68 in	4.50 in	12	5.875 in	4.5	170	269	2.25 in	0.13 in	10.5	0.98 in	0.875 in	0.188 in	117

Note: Dimensions in mm unless otherwise noted. For all available output shaft diameters, see page 413. For dimensions of compound gear units (ex: FT47R37) see page 401.

9 F - theSnuggler® Helical

F.. AM.. [NEMA dimensions]

42 018 00 11

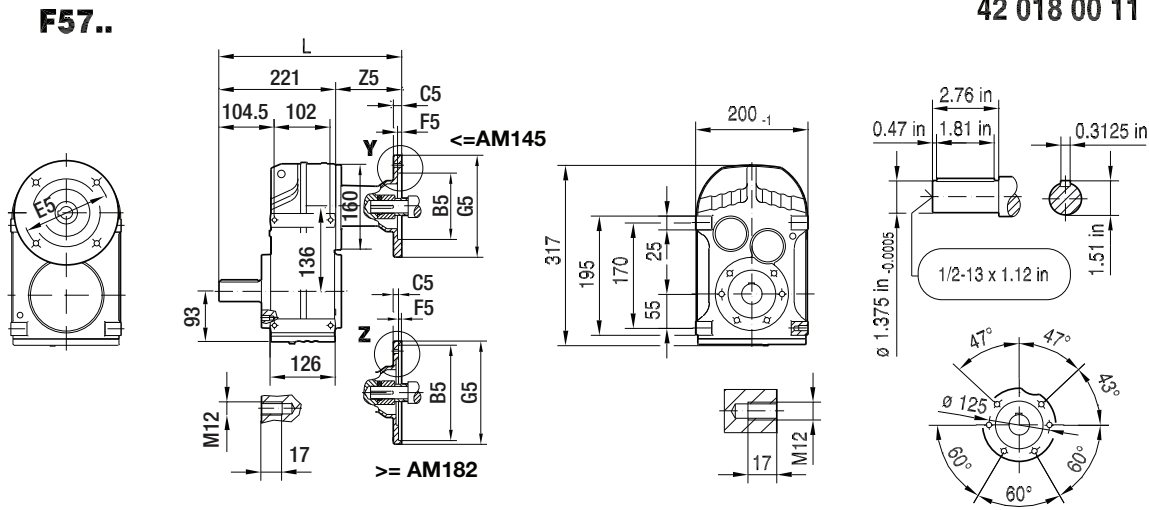

FA57B..

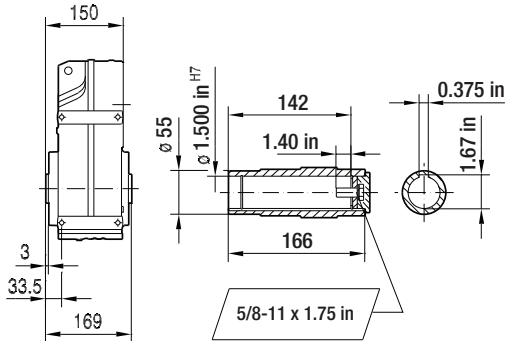

FV57B..

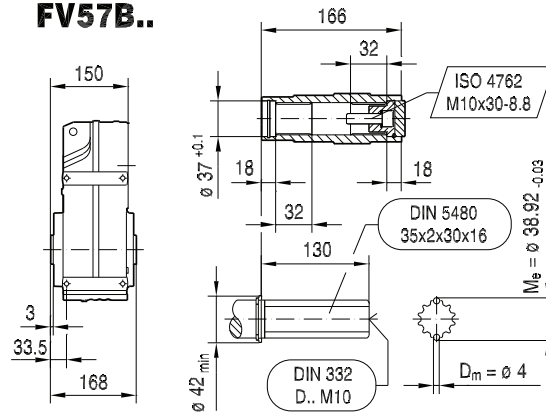

FH57B..

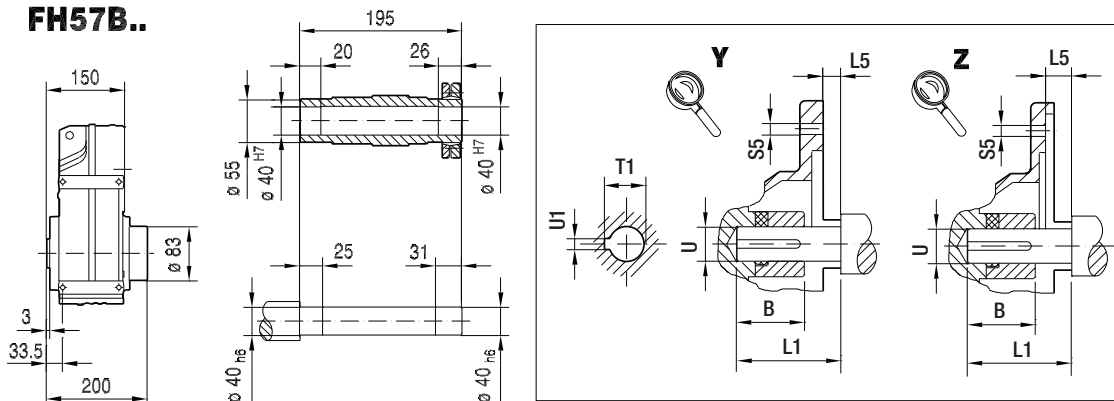

(→ 132)	B	B5	C5	E5	F5	G5	L	L1	L5	S5	T1	U	U1	Z5
AM56	1.23 in	4.50 in	11	5.875 in	4.5	170	308	1.88 in	-0.18 in	10.5	0.71 in	0.625 in	0.188 in	87
AM143	1.68 in	4.50 in	12	5.875 in	4.5	170	332	2.25 in	0.13 in	10.5	0.98 in	0.875 in	0.188 in	110.5
AM145	1.68 in	4.50 in	12	5.875 in	4.5	170	332	2.25 in	0.13 in	10.5	0.98 in	0.875 in	0.188 in	110.5
AM182	2.10 in	8.50 in	10	7.25 in	5	228	369	2.75 in	0.13 in	15	1.24 in	1.125 in	0.250 in	147.5
AM184	2.10 in	8.50 in	10	7.25 in	5	228	369	2.75 in	0.13 in	15	1.24 in	1.125 in	0.250 in	147.5
AM213/215	2.76 in	8.50 in	11	7.25 in	5	228	422	3.38 in	0.25 in	15	1.52 in	1.375 in	0.312 in	200.5

Note: Dimensions in mm unless otherwise noted. For all available output shaft diameters, see page 409. For dimensions of compound gear units (ex: F57R37) see page 401.

FF57..

42 019 00 11

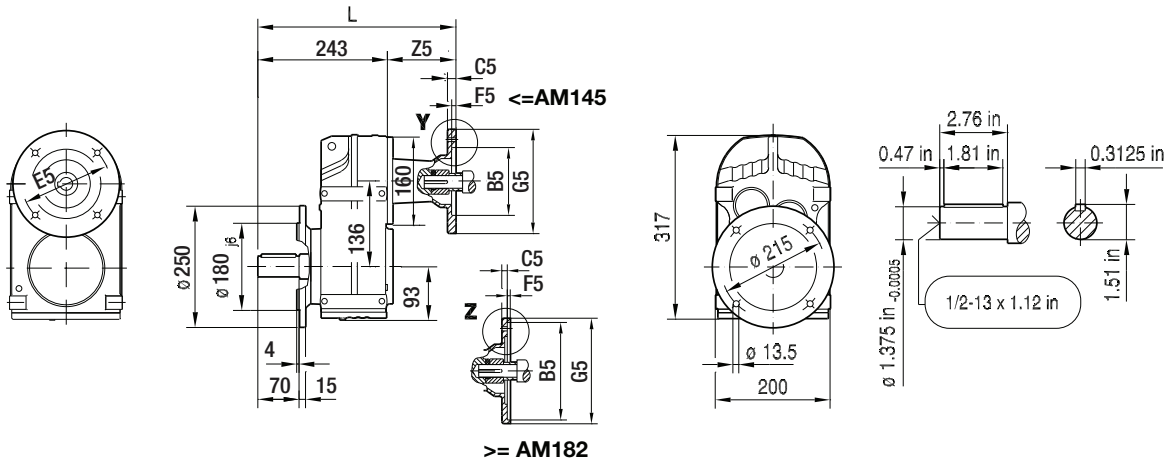

FAF57..

FVF57..

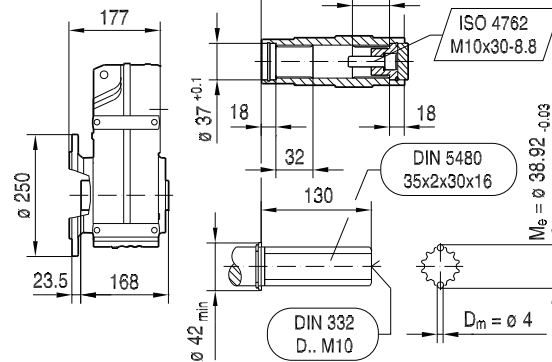
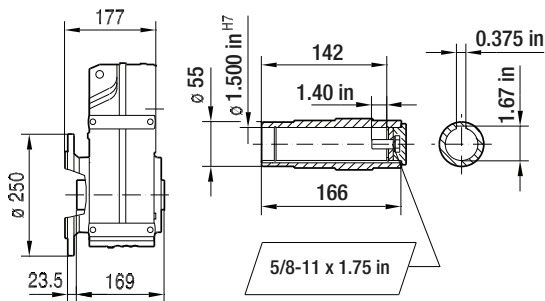

FHF57..

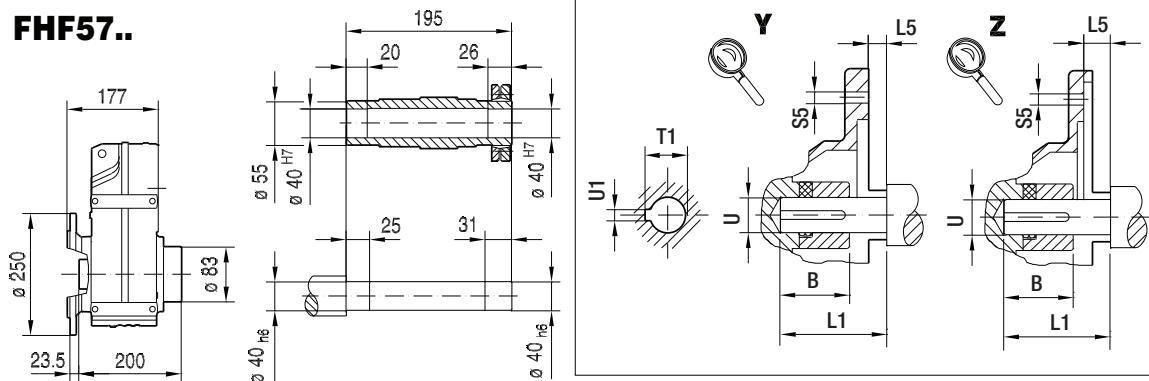

(→ 132)	B	B5	C5	E5	F5	G5	L	L1	L5	S5	T1	U	U1	Z5
AM56	1.23 in	4.50 in	11	5.875 in	4.5	170	330	1.88 in	-0.18 in	10.5	0.71 in	0.625 in	0.188 in	87
AM143	1.68 in	4.50 in	12	5.875 in	4.5	170	354	2.25 in	0.13 in	10.5	0.98 in	0.875 in	0.188 in	110.5
AM145	1.68 in	4.50 in	12	5.875 in	4.5	170	354	2.25 in	0.13 in	10.5	0.98 in	0.875 in	0.188 in	110.5
AM182	2.10 in	8.50 in	10	7.25 in	5	228	391	2.75 in	0.13 in	15	1.24 in	1.125 in	0.250 in	147.5
AM184	2.10 in	8.50 in	10	7.25 in	5	228	391	2.75 in	0.13 in	15	1.24 in	1.125 in	0.250 in	147.5
AM213/215	2.76 in	8.50 in	11	7.25 in	5	228	444	3.38 in	0.25 in	15	1.52 in	1.375 in	0.312 in	200.5

Note: Dimensions in mm unless otherwise noted. For all available output shaft diameters, see page 409. For dimensions of compound gear units (ex: FF57R37) see page 401.

9 F - theSnuggler® Helical

F.. AM.. [NEMA dimensions]

42 020 00 11

FA57..

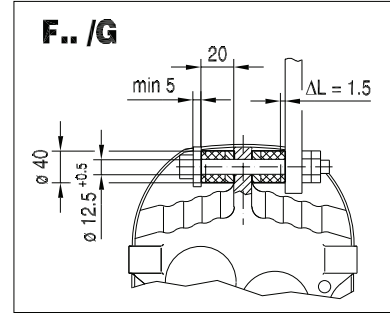
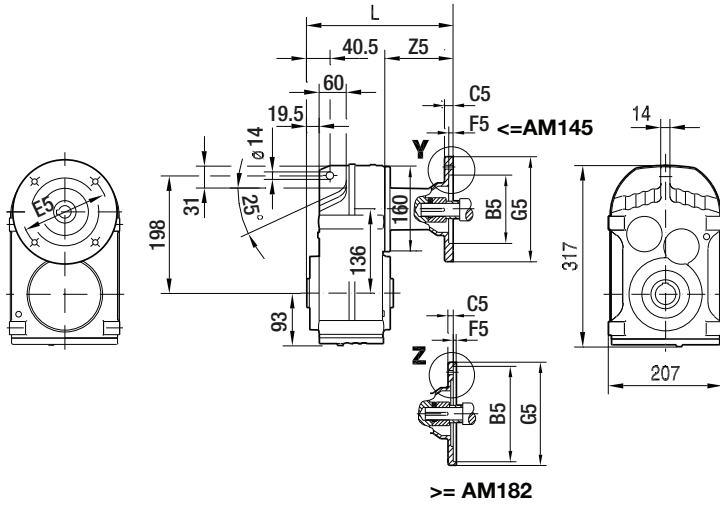

FA57..

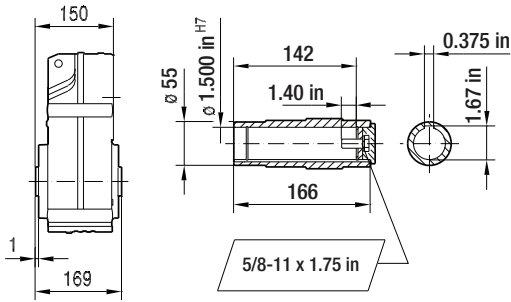

FV57..

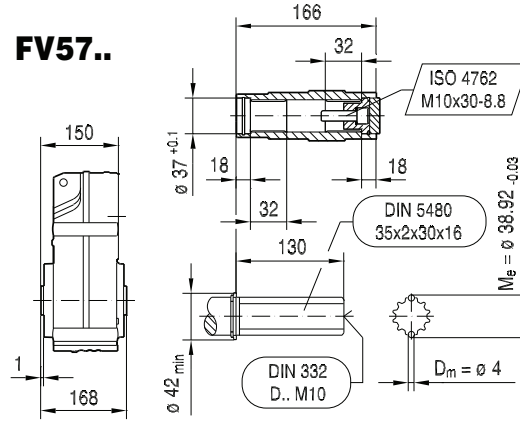

FH57..

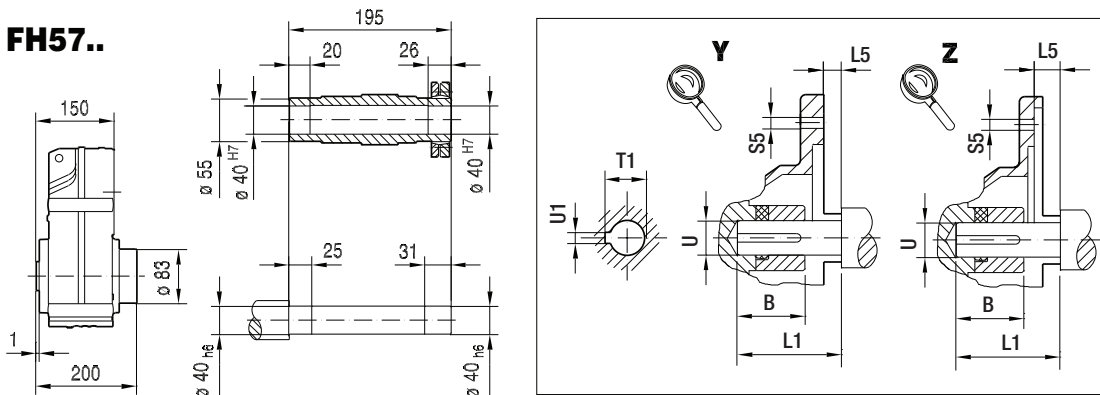

(→ 132)	B	B5	C5	E5	F5	G5	L	L1	L5	S5	T1	U	U1	Z5
AM56	1.23 in	4.50 in	11	5.875 in	4.5	170	237	1.88 in	-0.18 in	10.5	0.71 in	0.625 in	0.188 in	87
AM143	1.68 in	4.50 in	12	5.875 in	4.5	170	261	2.25 in	0.13 in	10.5	0.98 in	0.875 in	0.188 in	110.5
AM145	1.68 in	4.50 in	12	5.875 in	4.5	170	261	2.25 in	0.13 in	10.5	0.98 in	0.875 in	0.188 in	110.5
AM182	2.10 in	8.50 in	10	7.25 in	5	228	298	2.75 in	0.13 in	15	1.24 in	1.125 in	0.250 in	147.5
AM184	2.10 in	8.50 in	10	7.25 in	5	228	298	2.75 in	0.13 in	15	1.24 in	1.125 in	0.250 in	147.5
AM213/215	2.76 in	8.50 in	11	7.25 in	5	228	351	3.38 in	0.25 in	15	1.52 in	1.375 in	0.312 in	200.5

Note: Dimensions in mm unless otherwise noted. For all available output shaft diameters, see page 411. For dimensions of compound gear units (ex: FA57R37) see page 401.

FAZ57..

42 021 00 11

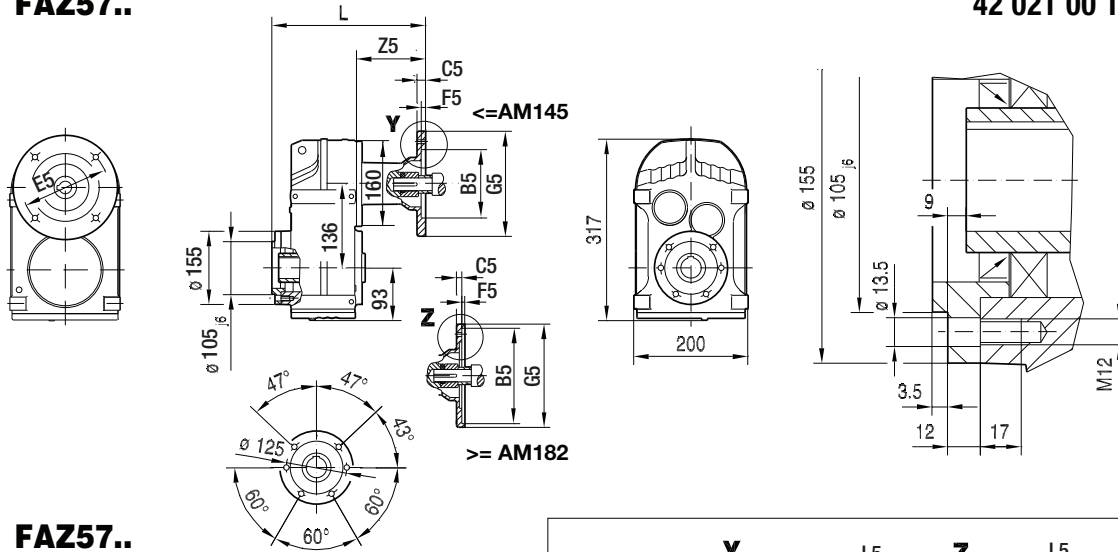

FAZ57..

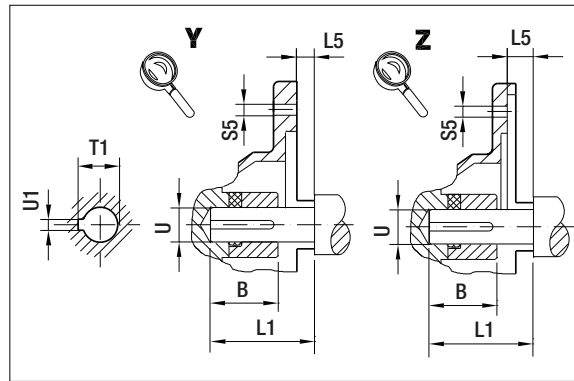
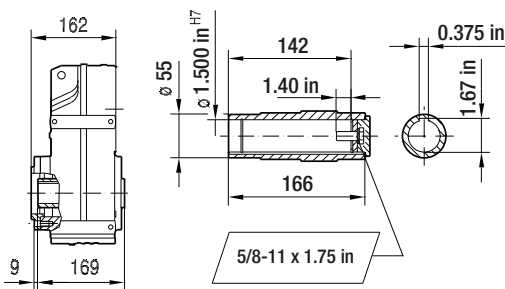

FHZ57..

FVZ57..

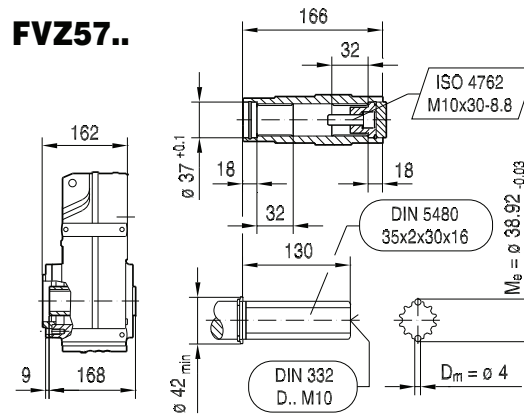
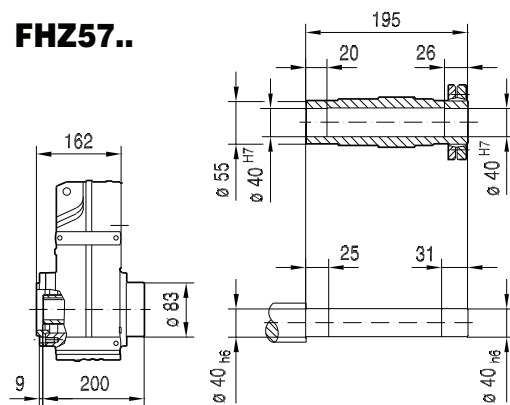

(→ 132)	B	B5	C5	E5	F5	G5	L	L1	L5	S5	T1	U	U1	Z5
AM56	1.23 in	4.50 in	11	5.875 in	4.5	170	249	1.88 in	-0.18 in	10.5	0.71 in	0.625 in	0.188 in	87
AM143	1.68 in	4.50 in	12	5.875 in	4.5	170	273	2.25 in	0.13 in	10.5	0.98 in	0.875 in	0.188 in	110.5
AM145	1.68 in	4.50 in	12	5.875 in	4.5	170	273	2.25 in	0.13 in	10.5	0.98 in	0.875 in	0.188 in	110.5
AM182	2.10 in	8.50 in	10	7.25 in	5	228	310	2.75 in	0.13 in	15	1.24 in	1.125 in	0.250 in	147.5
AM184	2.10 in	8.50 in	10	7.25 in	5	228	310	2.75 in	0.13 in	15	1.24 in	1.125 in	0.250 in	147.5
AM213/215	2.76 in	8.50 in	11	7.25 in	5	228	363	3.38 in	0.25 in	15	1.52 in	1.375 in	0.312 in	200.5

Note: Dimensions in mm unless otherwise noted. For all available output shaft diameters, see page 411. For dimensions of compound gear units (ex: FAZ57R37) see page 401.

9 F - theSnuggler® Helical

F.. AM.. [NEMA dimensions]

FT57..

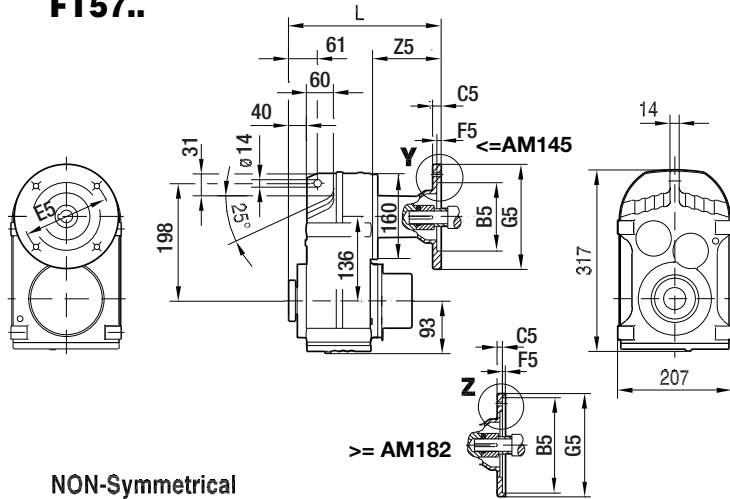

42 022 00 11

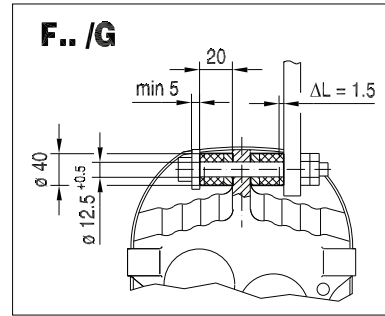

NON-Symmetrical FT57..

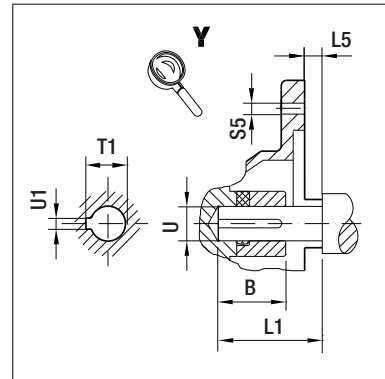
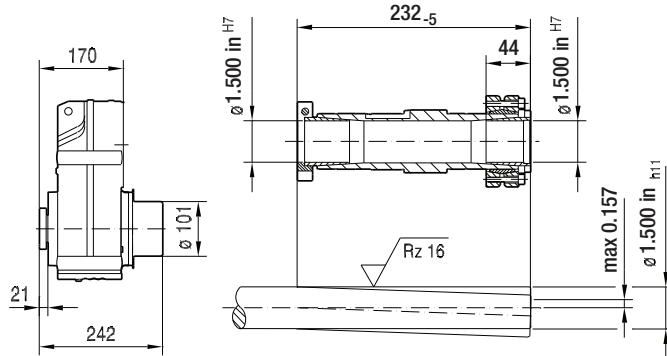

Symmetrical FT57..

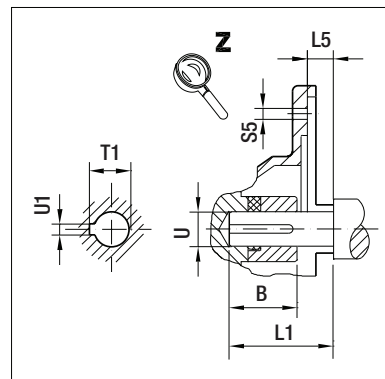
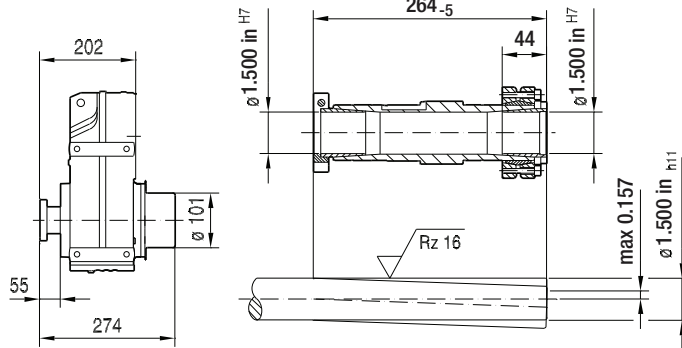

(→ 132)	B	B5	C5	E5	F5	G5	L	L1	L5	S5	T1	U	U1	Z5
AM56	1.23 in	4.50 in	11	5.875 in	4.5	170	257	1.88 in	-0.18 in	10.5	0.71 in	0.625 in	0.188 in	87
AM143	1.68 in	4.50 in	12	5.875 in	4.5	170	281	2.25 in	0.13 in	10.5	0.98 in	0.875 in	0.188 in	110.5
AM145	1.68 in	4.50 in	12	5.875 in	4.5	170	281	2.25 in	0.13 in	10.5	0.98 in	0.875 in	0.188 in	110.5
AM182	2.10 in	8.50 in	10	7.25 in	5	228	318	2.75 in	0.13 in	15	1.24 in	1.125 in	0.250 in	147.5
AM184	2.10 in	8.50 in	10	7.25 in	5	228	318	2.75 in	0.13 in	15	1.24 in	1.125 in	0.250 in	147.5
AM213/215	2.76 in	8.50 in	11	7.25 in	5	228	371	3.38 in	0.25 in	15	1.52 in	1.375 in	0.312 in	200.5

Note: Dimensions in mm unless otherwise noted. For all available output shaft diameters, see page 413. For dimensions of compound gear units (ex: FT57R37) see page 401.

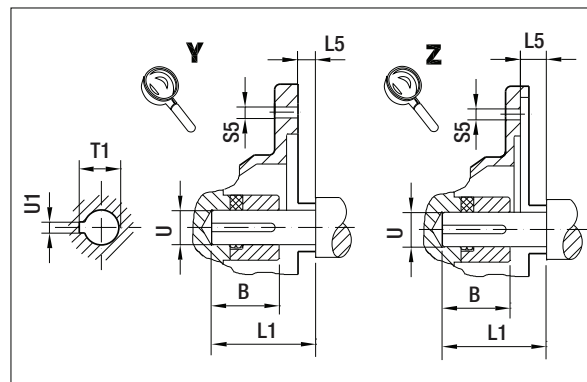
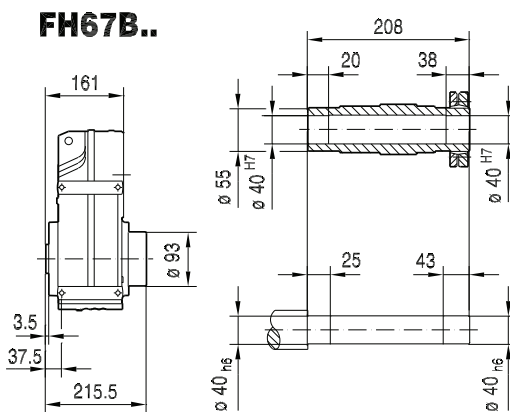
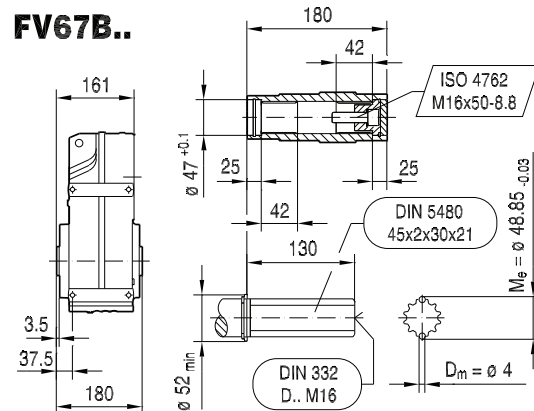
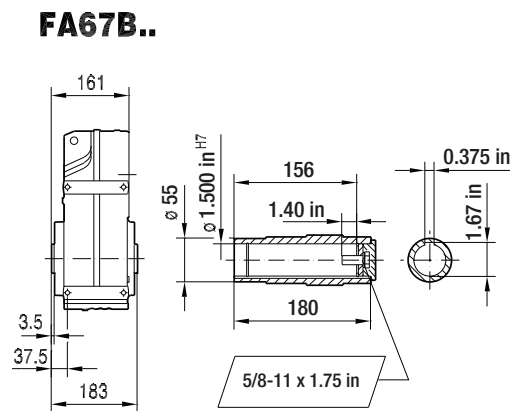
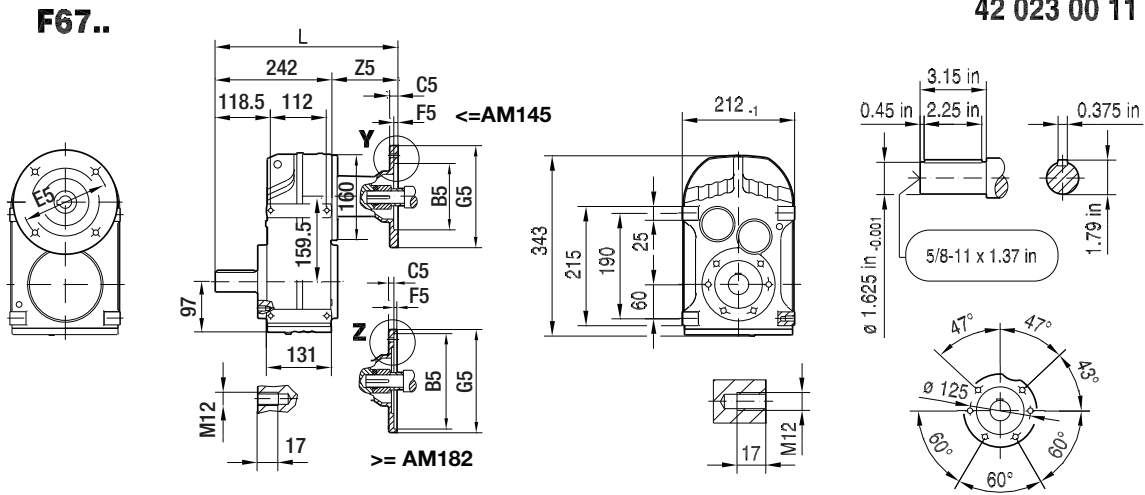

(→ 132)	B	B5	C5	E5	F5	G5	L	L1	L5	S5	T1	U	U1	Z5
AM56	1.23 in	4.50 in	11	5.875 in	4.5	170	329	1.88 in	-0.18 in	10.5	0.71 in	0.625 in	0.188 in	87
AM143	1.68 in	4.50 in	12	5.875 in	4.5	170	353	2.25 in	0.13 in	10.5	0.98 in	0.875 in	0.188 in	110.5
AM145	1.68 in	4.50 in	12	5.875 in	4.5	170	353	2.25 in	0.13 in	10.5	0.98 in	0.875 in	0.188 in	110.5
AM182	2.10 in	8.50 in	10	7.25 in	5	228	390	2.75 in	0.13 in	15	1.24 in	1.125 in	0.250 in	147.5
AM184	2.10 in	8.50 in	10	7.25 in	5	228	390	2.75 in	0.13 in	15	1.24 in	1.125 in	0.250 in	147.5
AM213/215	2.76 in	8.50 in	11	7.25 in	5	228	443	3.38 in	0.25 in	15	1.52 in	1.375 in	0.312 in	200.5

Note: Dimensions in mm unless otherwise noted. For all available output shaft diameters, see page 409. For dimensions of compound gear units (ex: F67R37) see page 401.

9 F - theSnuggler® Helical

F.. AM.. [NEMA dimensions]

FF67..

42 024 00 11

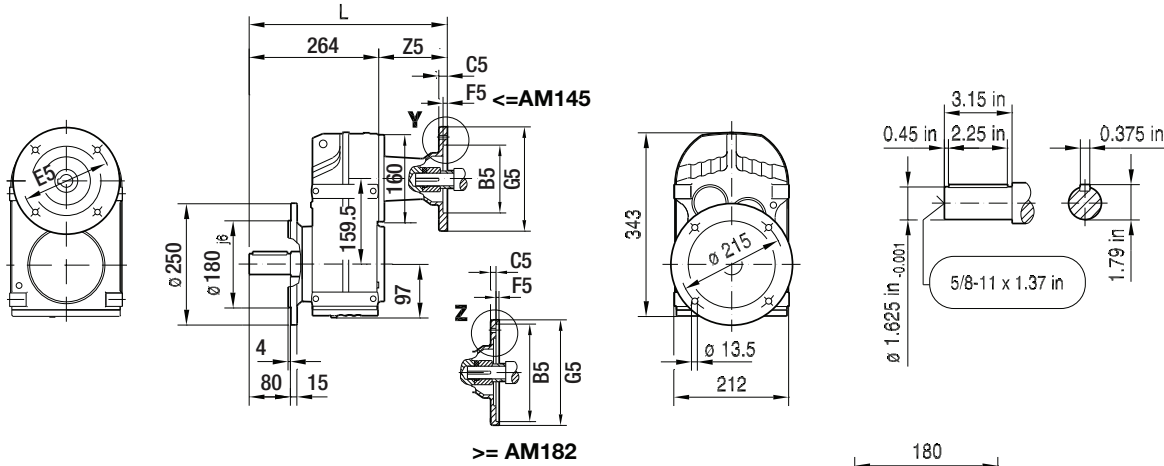

FAF67..

FVF67..

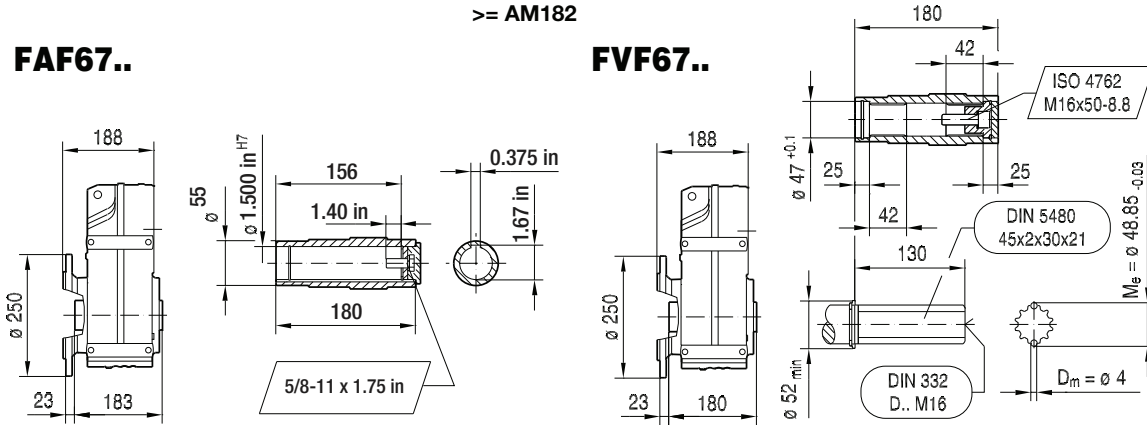

FHF67..

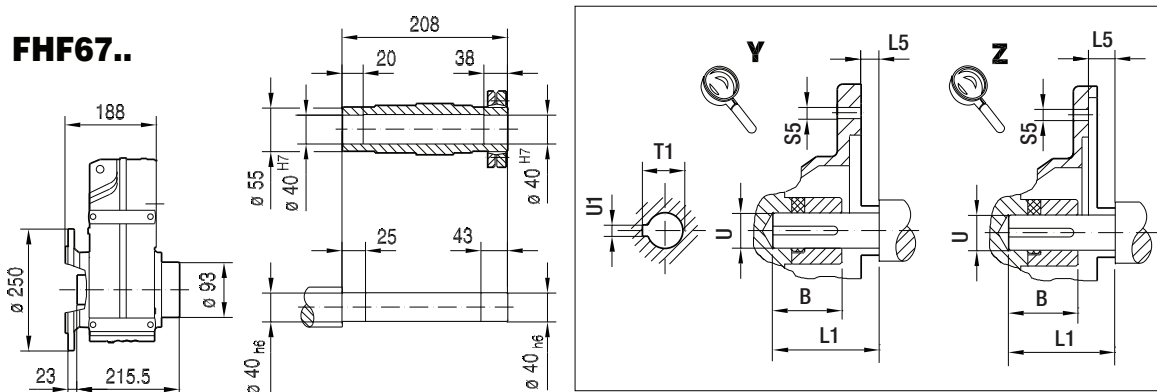

(→ 132)	B	B5	C5	E5	F5	G5	L	L1	L5	S5	T1	U	U1	Z5
AM56	1.23 in	4.50 in	11	5.875 in	4.5	170	351	1.88 in	-0.18 in	10.5	0.71 in	0.625 in	0.188 in	87
AM143	1.68 in	4.50 in	12	5.875 in	4.5	170	375	2.25 in	0.13 in	10.5	0.98 in	0.875 in	0.188 in	110.5
AM145	1.68 in	4.50 in	12	5.875 in	4.5	170	375	2.25 in	0.13 in	10.5	0.98 in	0.875 in	0.188 in	110.5
AM182	2.10 in	8.50 in	10	7.25 in	5	228	412	2.75 in	0.13 in	15	1.24 in	1.125 in	0.250 in	147.5
AM184	2.10 in	8.50 in	10	7.25 in	5	228	412	2.75 in	0.13 in	15	1.24 in	1.125 in	0.250 in	147.5
AM213/215	2.76 in	8.50 in	11	7.25 in	5	228	465	3.38 in	0.25 in	15	1.52 in	1.375 in	0.312 in	200.5

Note: Dimensions in mm unless otherwise noted. For all available output shaft diameters, see page 409. For dimensions of compound gear units (ex: FF67R37) see page 401.

FA67..

42 025 00 11

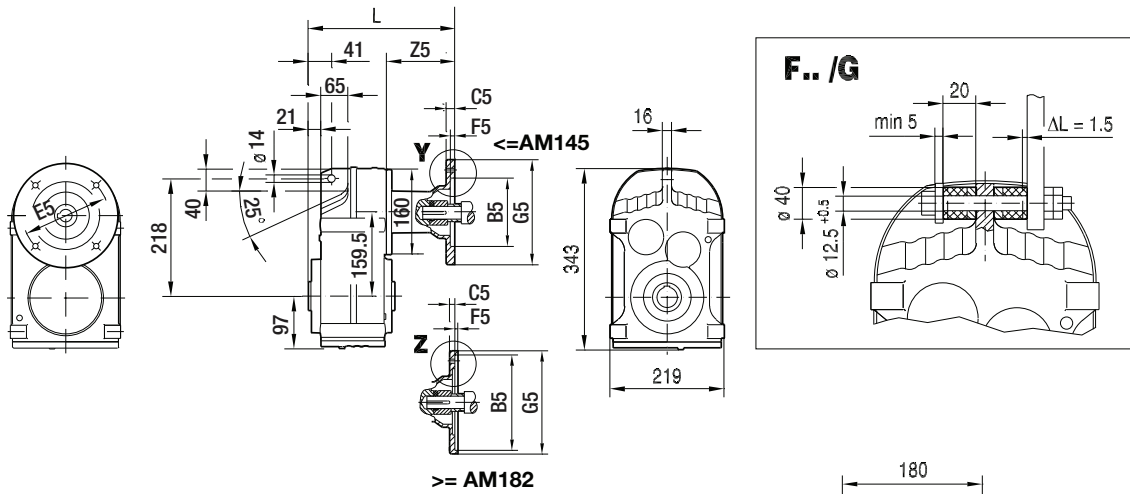

FA67..

FV67..

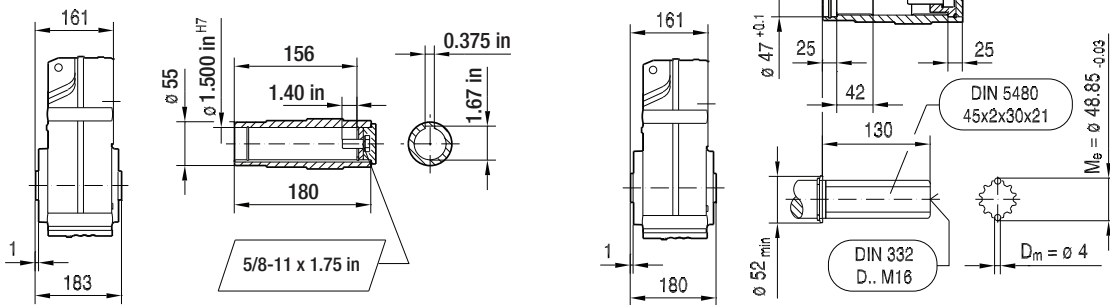

FH67..

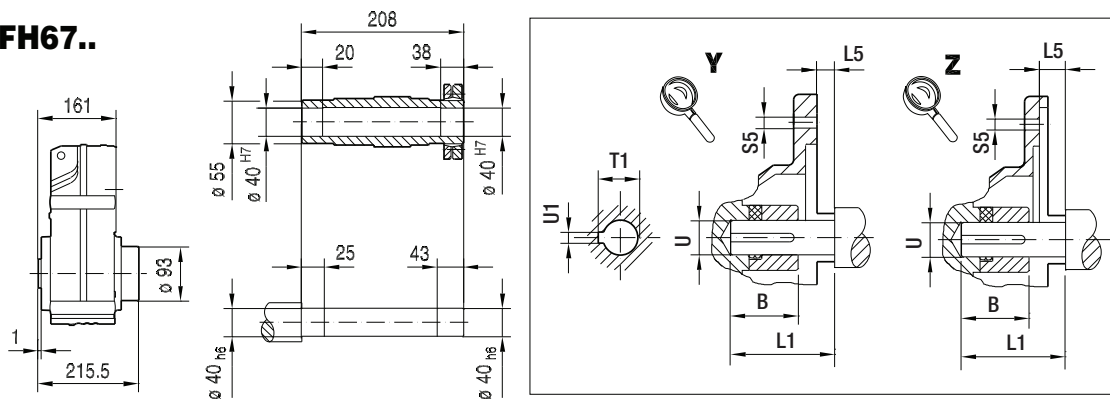

(→ 132)	B	B5	C5	E5	F5	G5	L	L1	L5	S5	T1	U	U1	Z5
AM56	1.23 in	4.50 in	11	5.875 in	4.5	170	248	1.88 in	-0.18 in	10.5	0.71 in	0.625 in	0.188 in	87
AM143	1.68 in	4.50 in	12	5.875 in	4.5	170	272	2.25 in	0.13 in	10.5	0.98 in	0.875 in	0.188 in	110.5
AM145	1.68 in	4.50 in	12	5.875 in	4.5	170	272	2.25 in	0.13 in	10.5	0.98 in	0.875 in	0.188 in	110.5
AM182	2.10 in	8.50 in	10	7.25 in	5	228	309	2.75 in	0.13 in	15	1.24 in	1.125 in	0.250 in	147.5
AM184	2.10 in	8.50 in	10	7.25 in	5	228	309	2.75 in	0.13 in	15	1.24 in	1.125 in	0.250 in	147.5
AM213/215	2.76 in	8.50 in	11	7.25 in	5	228	362	3.38 in	0.25 in	15	1.52 in	1.375 in	0.312 in	200.5

Note: Dimensions in mm unless otherwise noted. For all available output shaft diameters, see page 411. For dimensions of compound gear units (ex: FA67R37) see page 401.

9 F - theSnuggler® Helical

F.. AM.. [NEMA dimensions]

FAZ67..

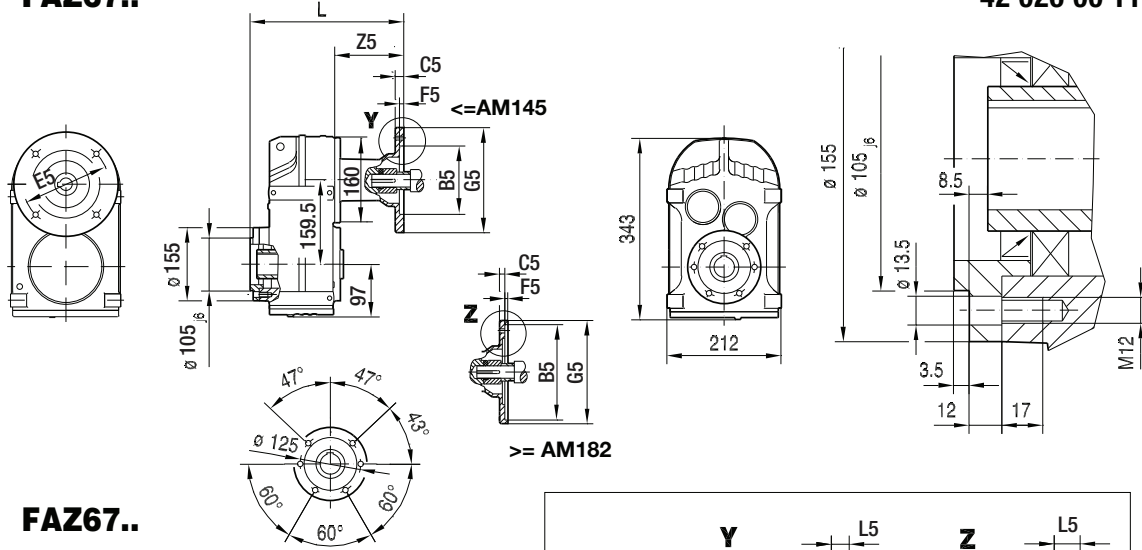

42 026 00 11

FAZ67..

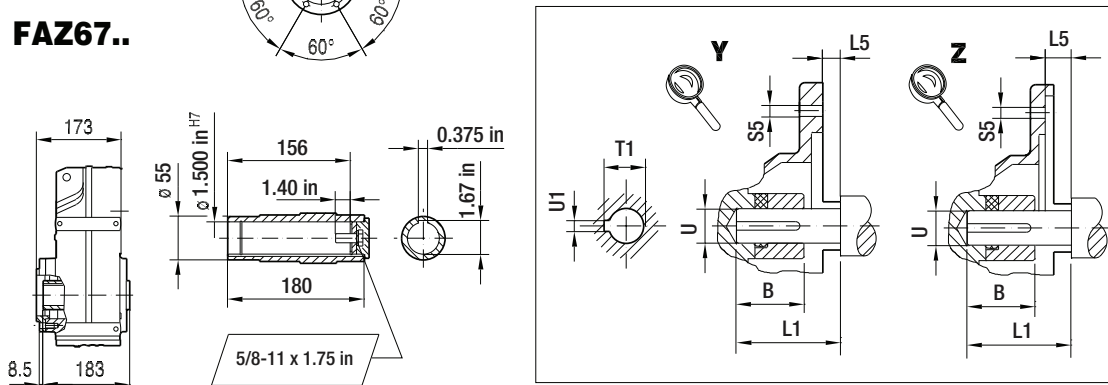

FHZ67..

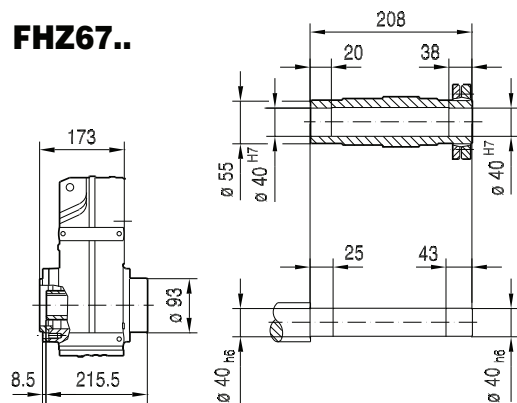

FVZ67..

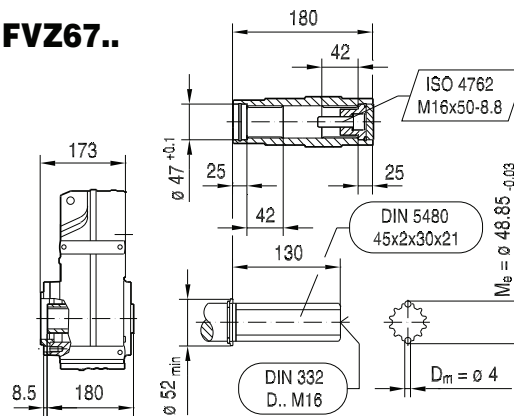

(→ 132)	B	B5	C5	E5	F5	G5	L	L1	L5	S5	T1	U	U1	Z5
AM56	1.23 in	4.50 in	11	5.875 in	4.5	170	260	1.88 in	-0.18 in	10.5	0.71 in	0.625 in	0.188 in	87
AM143	1.68 in	4.50 in	12	5.875 in	4.5	170	284	2.25 in	0.13 in	10.5	0.98 in	0.875 in	0.188 in	110.5
AM145	1.68 in	4.50 in	12	5.875 in	4.5	170	284	2.25 in	0.13 in	10.5	0.98 in	0.875 in	0.188 in	110.5
AM182	2.10 in	8.50 in	10	7.25 in	5	228	321	2.75 in	0.13 in	15	1.24 in	1.125 in	0.250 in	147.5
AM184	2.10 in	8.50 in	10	7.25 in	5	228	321	2.75 in	0.13 in	15	1.24 in	1.125 in	0.250 in	147.5
AM213/215	2.76 in	8.50 in	11	7.25 in	5	228	374	3.38 in	0.25 in	15	1.52 in	1.375 in	0.312 in	200.5

Note: Dimensions in mm unless otherwise noted. For all available output shaft diameters, see page 411. For dimensions of compound gear units (ex: FAZ67R37) see page 401.

FT67..

42 027 00 11

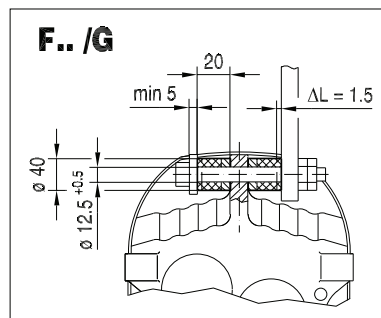
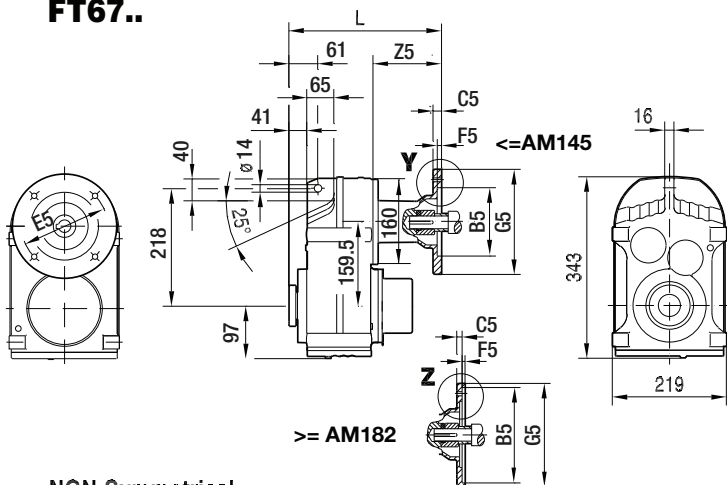

**NON-Symmetrical
FT67..**

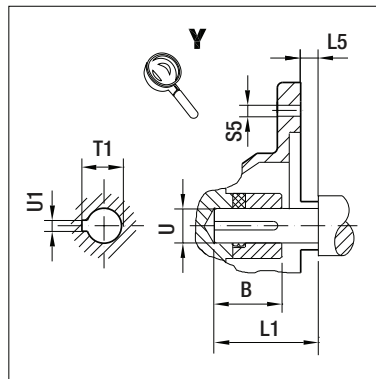
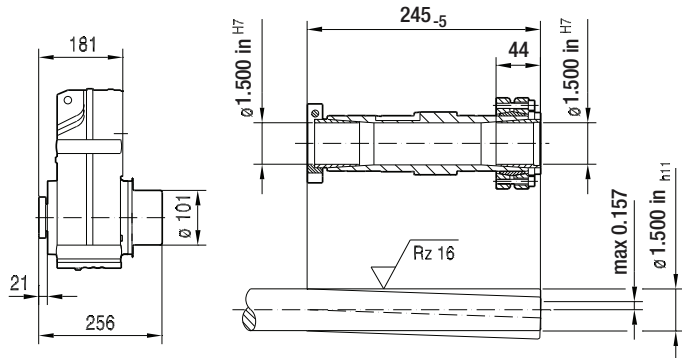

**Symmetrical
FT67..**

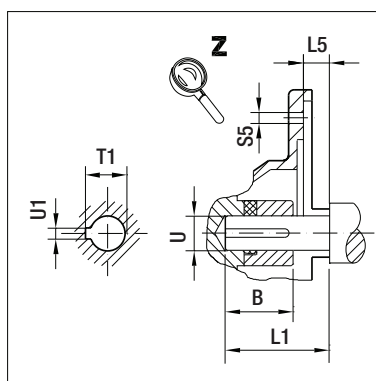
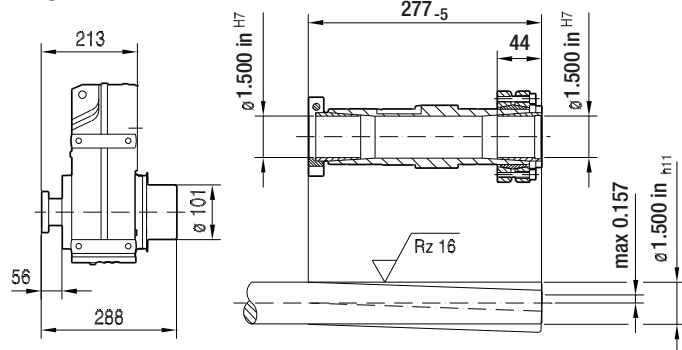

(→ 132)	B	B5	C5	E5	F5	G5	L	L1	L5	S5	T1	U	U1	Z5
AM56	1.23 in	4.50 in	11	5.875 in	4.5	170	268	1.88 in	-0.18 in	10.5	0.71 in	0.625 in	0.188 in	87
AM143	1.68 in	4.50 in	12	5.875 in	4.5	170	292	2.25 in	0.13 in	10.5	0.98 in	0.875 in	0.188 in	110.5
AM145	1.68 in	4.50 in	12	5.875 in	4.5	170	292	2.25 in	0.13 in	10.5	0.98 in	0.875 in	0.188 in	110.5
AM182	2.10 in	8.50 in	10	7.25 in	5	228	329	2.75 in	0.13 in	15	1.24 in	1.125 in	0.250 in	147.5
AM184	2.10 in	8.50 in	10	7.25 in	5	228	329	2.75 in	0.13 in	15	1.24 in	1.125 in	0.250 in	147.5
AM213/215	2.76 in	8.50 in	11	7.25 in	5	228	382	3.38 in	0.25 in	15	1.52 in	1.375 in	0.312 in	200.5

Note: Dimensions in mm unless otherwise noted. For all available output shaft diameters, see page 413. For dimensions of compound gear units (ex: FT67R37) see page 401.

9 F - theSnuggler® Helical

F.. AM.. [NEMA dimensions]

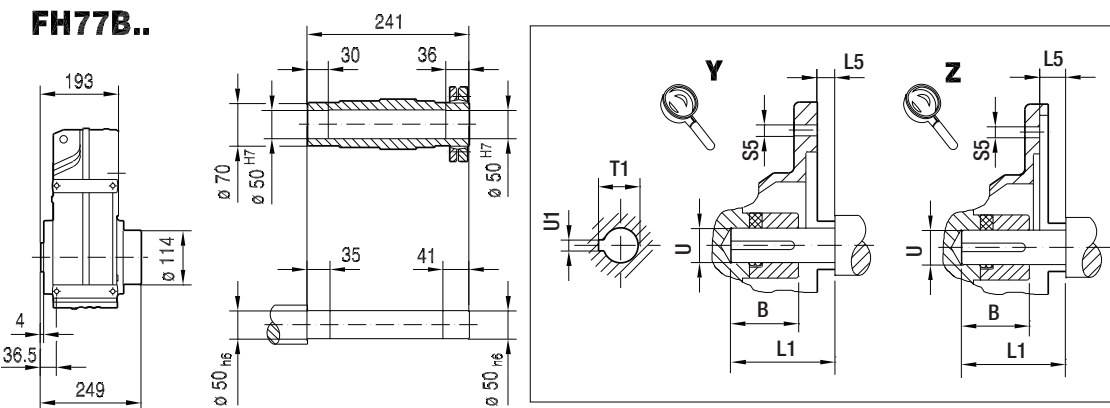
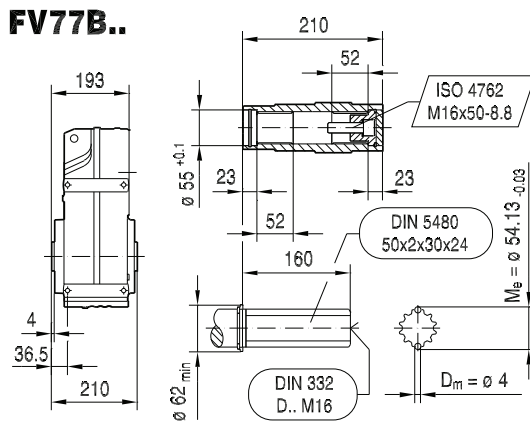
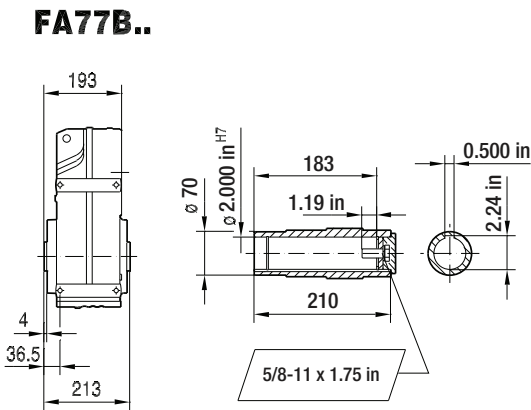
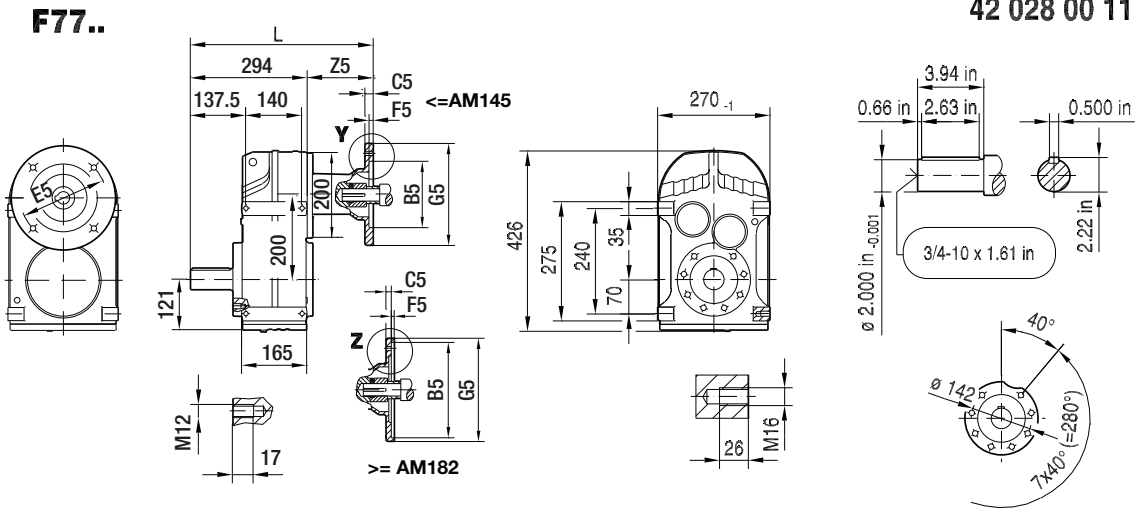

(→ 132)	B	B5	C5	E5	F5	G5	L	L1	L5	S5	T1	U	U1	Z5
AM56	1.23 in	4.50 in	11	5.875 in	4.5	170	375	1.88 in	-0.18 in	10.5	0.71 in	0.625 in	0.188 in	81
AM143	1.68 in	4.50 in	12	5.875 in	4.5	170	398	2.25 in	0.13 in	10.5	0.98 in	0.875 in	0.188 in	103.5
AM145	1.68 in	4.50 in	12	5.875 in	4.5	170	398	2.25 in	0.13 in	10.5	0.98 in	0.875 in	0.188 in	103.5
AM182	2.10 in	8.50 in	10	7.25 in	5	228	434	2.75 in	0.13 in	15	1.24 in	1.125 in	0.250 in	139.5
AM184	2.10 in	8.50 in	10	7.25 in	5	228	434	2.75 in	0.13 in	15	1.24 in	1.125 in	0.250 in	139.5
AM213/215	2.76 in	8.50 in	11	7.25 in	5	228	483	3.38 in	0.25 in	15	1.52 in	1.375 in	0.312 in	188.5

Note: Dimensions in mm unless otherwise noted. For all available output shaft diameters, see page 409. For dimensions of compound gear units (ex: FA77R37) see page 401.

FF77..

42 029 00 11

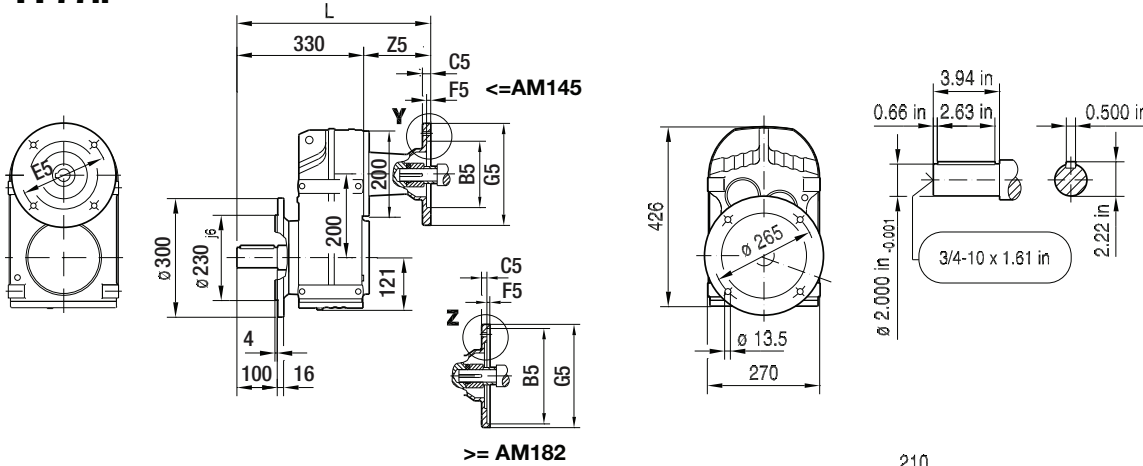

FAF77..

FVF77..

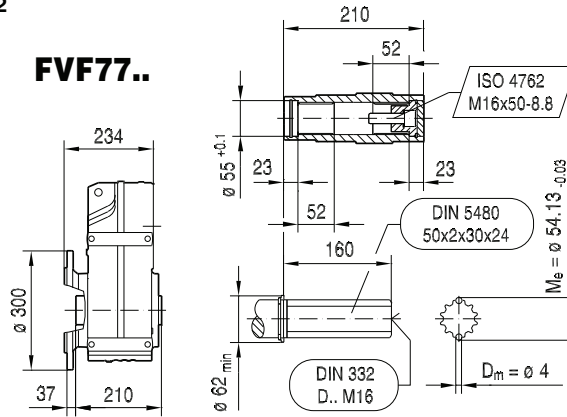
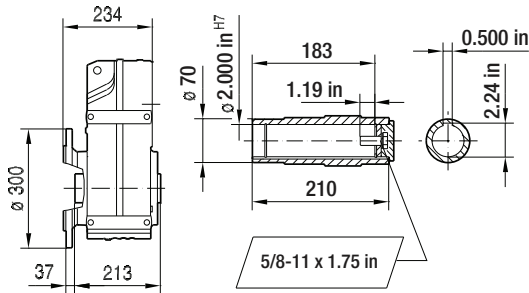

FHF77..

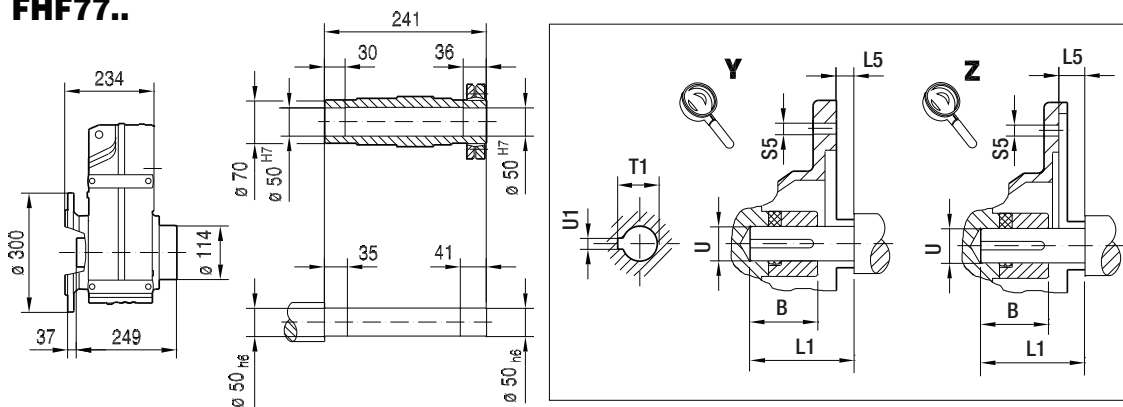

(→ 132)	B	B5	C5	E5	F5	G5	L	L1	L5	S5	T1	U	U1	Z5
AM56	1.23 in	4.50 in	11	5.875 in	4.5	170	411	1.88 in	-0.18 in	10.5	0.71 in	0.625 in	0.188 in	81
AM143	1.68 in	4.50 in	12	5.875 in	4.5	170	434	2.25 in	0.13 in	10.5	0.98 in	0.875 in	0.188 in	103.5
AM145	1.68 in	4.50 in	12	5.875 in	4.5	170	434	2.25 in	0.13 in	10.5	0.98 in	0.875 in	0.188 in	103.5
AM182	2.10 in	8.50 in	10	7.25 in	5	228	470	2.75 in	0.13 in	15	1.24 in	1.125 in	0.250 in	139.5
AM184	2.10 in	8.50 in	10	7.25 in	5	228	470	2.75 in	0.13 in	15	1.24 in	1.125 in	0.250 in	139.5
AM213/215	2.76 in	8.50 in	11	7.25 in	5	228	519	3.38 in	0.25 in	15	1.52 in	1.375 in	0.312 in	188.5

Note: Dimensions in mm unless otherwise noted. For all available output shaft diameters, see page 409. For dimensions of compound gear units (ex: FAF77R37) see page 401.

FAZ77..

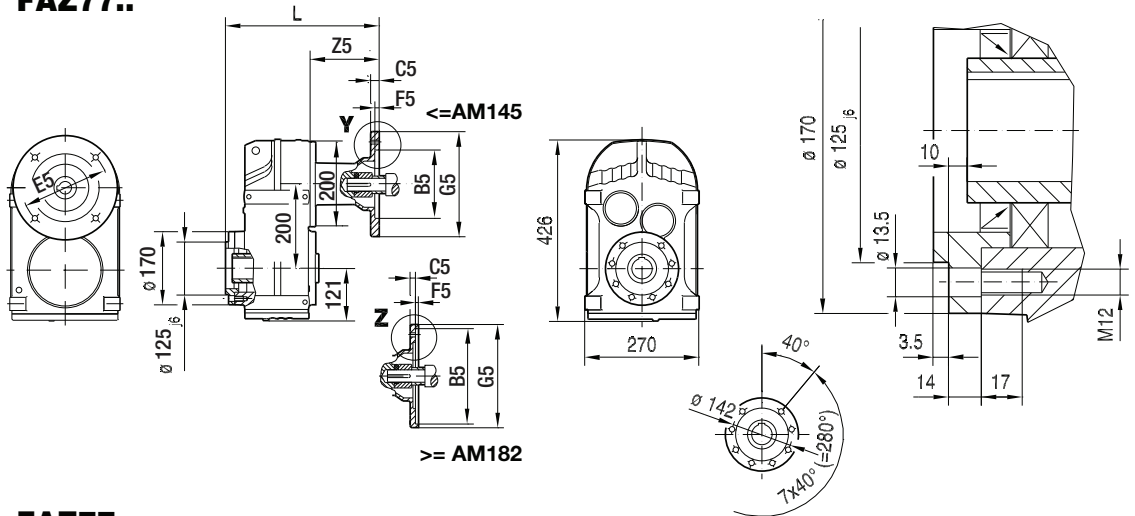

42 031 00 11

FAZ77..

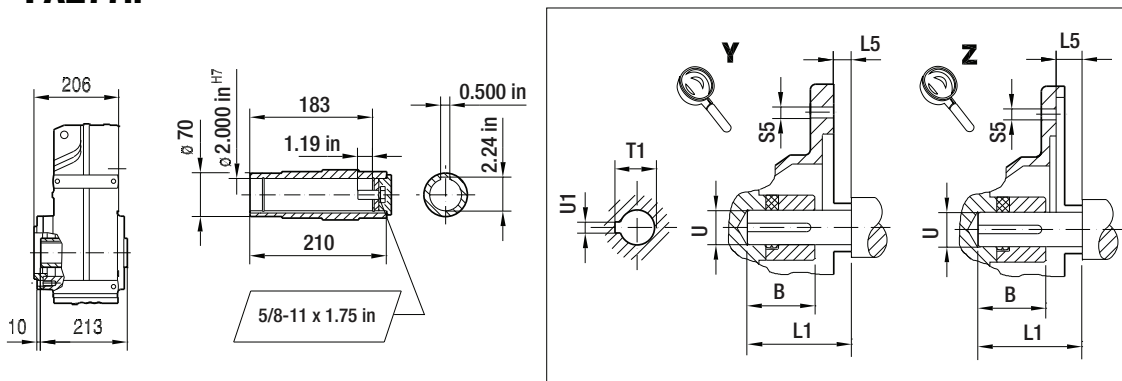

FHZ77..

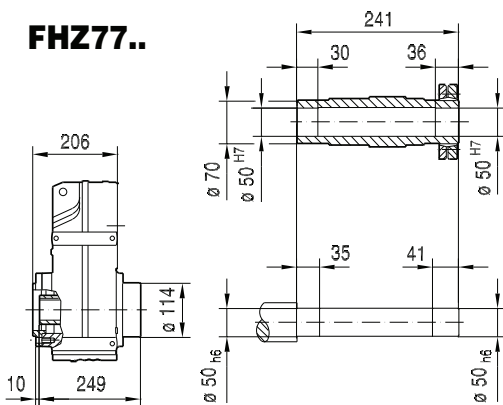

FVZ77..

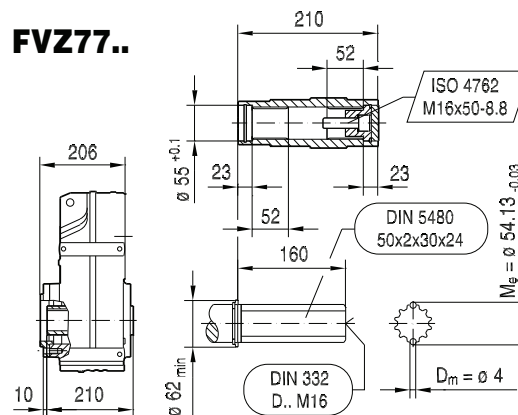

(→ 132)	B	B5	C5	E5	F5	G5	L	L1	L5	S5	T1	U	U1	Z5
AM56	1.23 in	4.50 in	11	5.875 in	4.5	170	287	1.88 in	-0.18 in	10.5	0.71 in	0.625 in	0.188 in	81
AM143	1.68 in	4.50 in	12	5.875 in	4.5	170	310	2.25 in	0.13 in	10.5	0.98 in	0.875 in	0.188 in	103.5
AM145	1.68 in	4.50 in	12	5.875 in	4.5	170	310	2.25 in	0.13 in	10.5	0.98 in	0.875 in	0.188 in	103.5
AM182	2.10 in	8.50 in	10	7.25 in	5	228	346	2.75 in	0.13 in	15	1.24 in	1.125 in	0.250 in	139.5
AM184	2.10 in	8.50 in	10	7.25 in	5	228	346	2.75 in	0.13 in	15	1.24 in	1.125 in	0.250 in	139.5
AM213/215	2.76 in	8.50 in	11	7.25 in	5	228	395	3.38 in	0.25 in	15	1.52 in	1.375 in	0.312 in	188.5

Note: Dimensions in mm unless otherwise noted. For all available output shaft diameters, see page 411. For dimensions of compound gear units (ex: FAZ77R37) see page 401.

9 F - theSnuggler® Helical

F.. AM.. [NEMA dimensions]

42 032 00 11

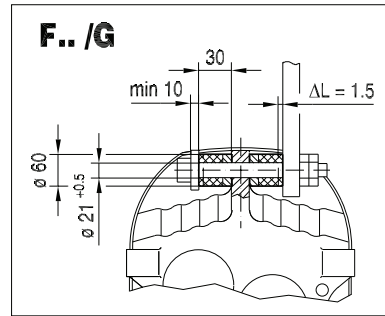
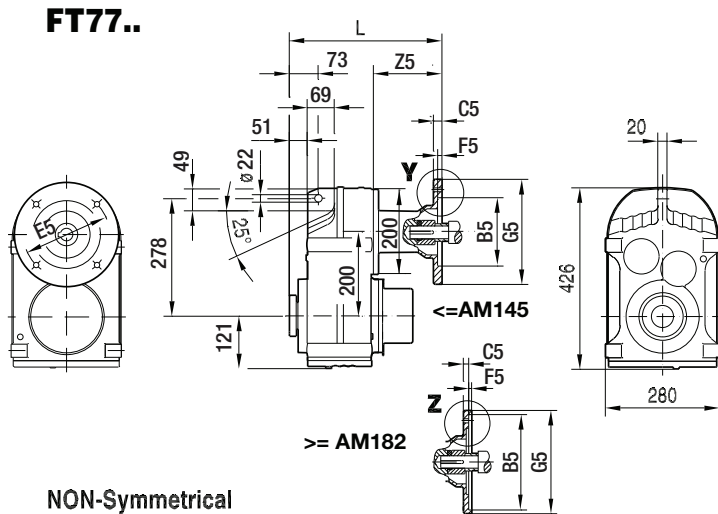

**NON-Symmetrical
FT77..**

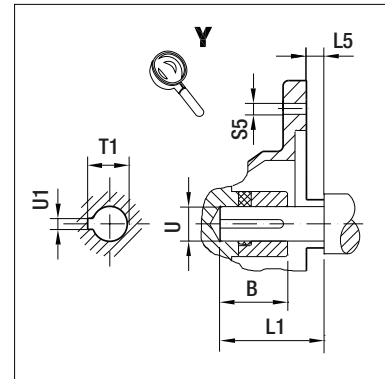
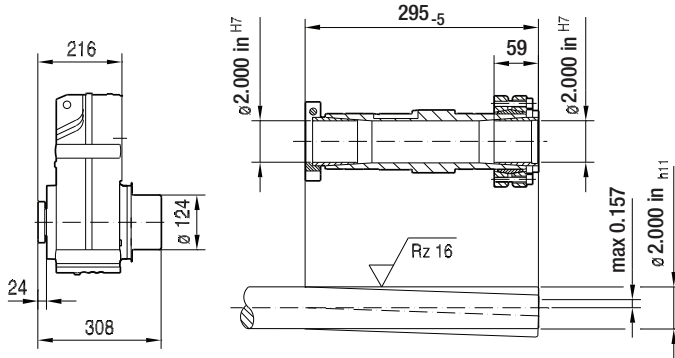

**Symmetrical
FT77..**

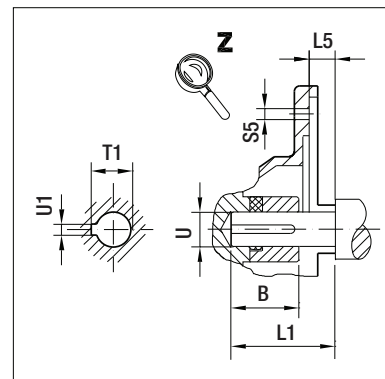
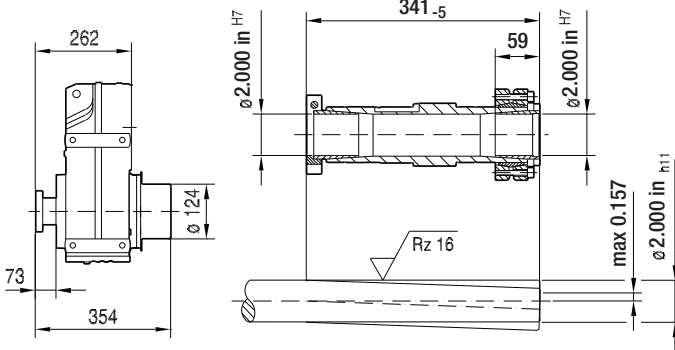

(→ 132)	B	B5	C5	E5	F5	G5	L	L1	L5	S5	T1	U	U1	Z5
AM56	1.23 in	4.50 in	11	5.875 in	4.5	170	297	1.88 in	-0.18 in	10.5	0.71 in	0.625 in	0.188 in	81
AM143	1.68 in	4.50 in	12	5.875 in	4.5	170	320	2.25 in	0.13 in	10.5	0.98 in	0.875 in	0.188 in	103.5
AM145	1.68 in	4.50 in	12	5.875 in	4.5	170	320	2.25 in	0.13 in	10.5	0.98 in	0.875 in	0.188 in	103.5
AM182	2.10 in	8.50 in	10	7.25 in	5	228	356	2.75 in	0.13 in	15	1.24 in	1.125 in	0.250 in	139.5
AM184	2.10 in	8.50 in	10	7.25 in	5	228	356	2.75 in	0.13 in	15	1.24 in	1.125 in	0.250 in	139.5
AM213/215	2.76 in	8.50 in	11	7.25 in	5	228	405	3.38 in	0.25 in	15	1.52 in	1.375 in	0.312 in	188.5

Note: Dimensions in mm unless otherwise noted. For all available output shaft diameters, see page 413. For dimensions of compound gear units (ex: FT77R37) see page 401.

F87..

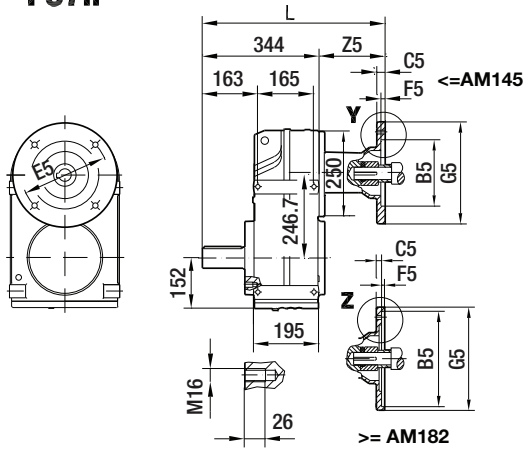

42 033 00 11

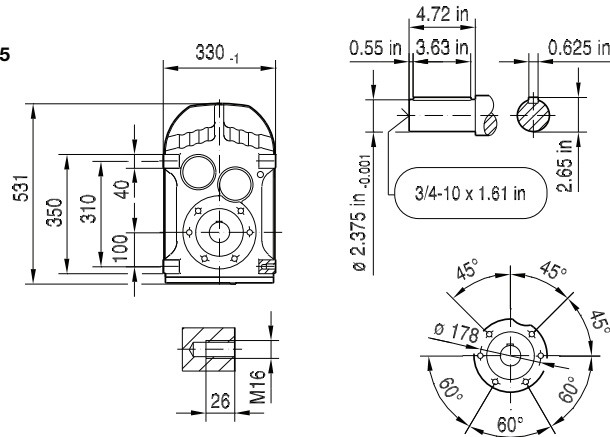

FA87B..

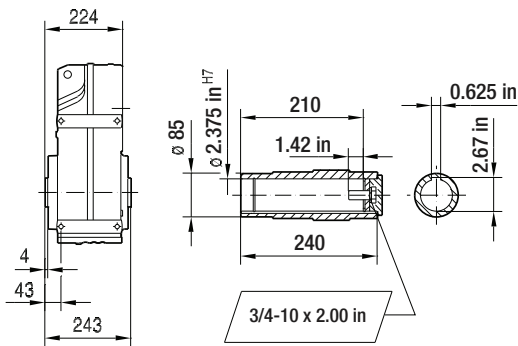

FV87B..

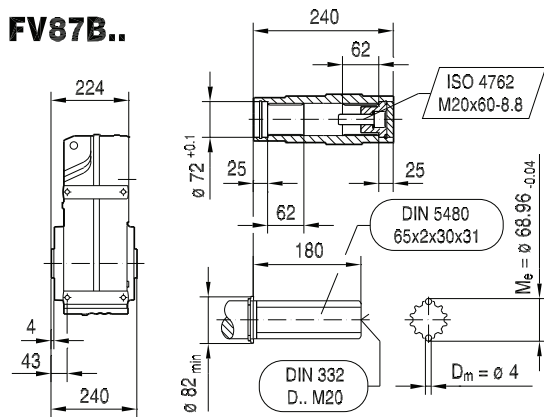

FH87B..

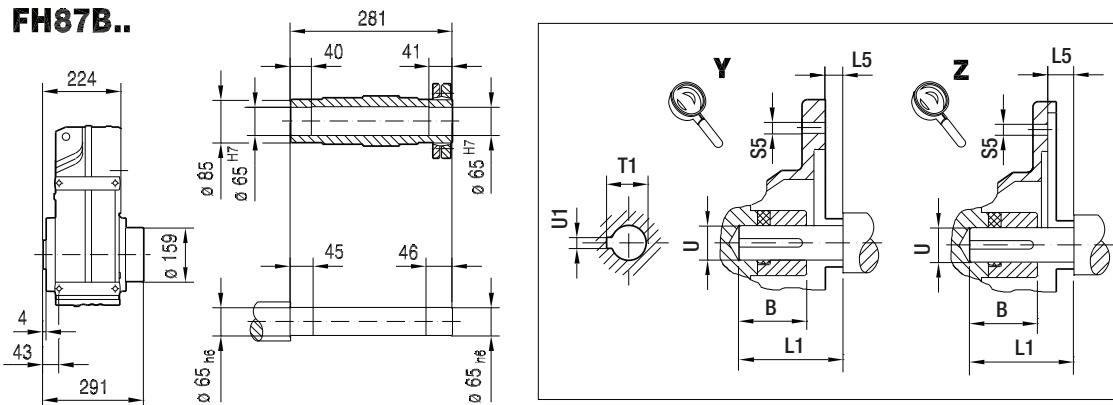

(→ 132)	B	B5	C5	E5	F5	G5	L	L1	L5	S5	T1	U	U1	Z5
AM143	1.68 in	4.50 in	12	5.875 in	4.5	170	443	2.25 in	0.13 in	10.5	0.98 in	0.875 in	0.188 in	98.5
AM145	1.68 in	4.50 in	12	5.875 in	4.5	170	443	2.25 in	0.13 in	10.5	0.98 in	0.875 in	0.188 in	98.5
AM182	2.10 in	8.50 in	10	7.25 in	5	228	479	2.75 in	0.13 in	15	1.24 in	1.125 in	0.250 in	134.5
AM184	2.10 in	8.50 in	10	7.25 in	5	228	479	2.75 in	0.13 in	15	1.24 in	1.125 in	0.250 in	134.5
AM213/215	2.76 in	8.50 in	11	7.25 in	5	228	528	3.38 in	0.25 in	15	1.52 in	1.375 in	0.312 in	183.5
AM254/256	3.65 in	8.50 in	14	7.25 in	5	228	578	4.00 in	0.25 in	15	1.80 in	1.625 in	0.375 in	234
AM284/286	4.00 in	10.50 in	15	9.00 in	5	286	585	4.62 in	0.25 in	15	2.10 in	1.875 in	0.500 in	241

Note: Dimensions in mm unless otherwise noted. For all available output shaft diameters, see page 409. For dimensions of compound gear units (ex: F87R57) see page 401.

9 F - theSnuggler® Helical

F.. AM.. [NEMA dimensions]

42 034 00 11

FF87..

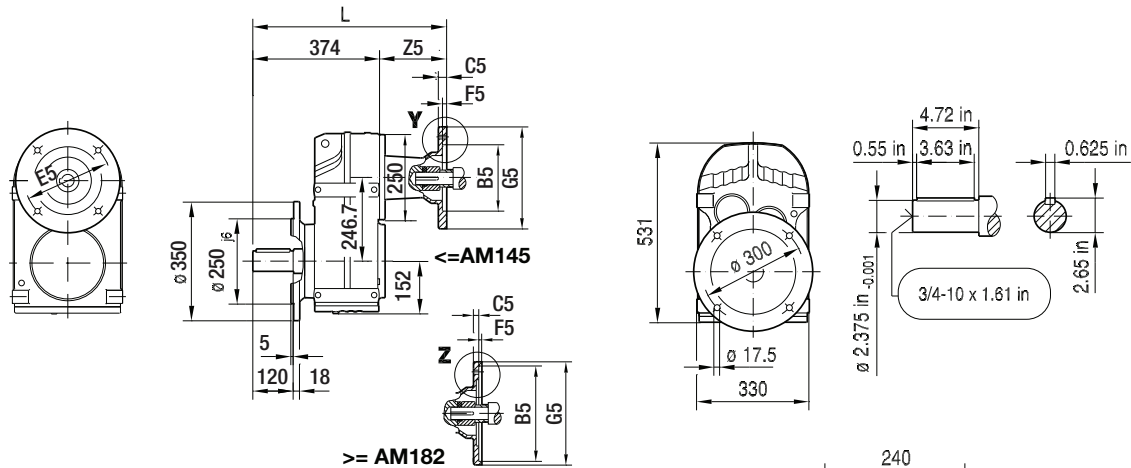

FAF87..

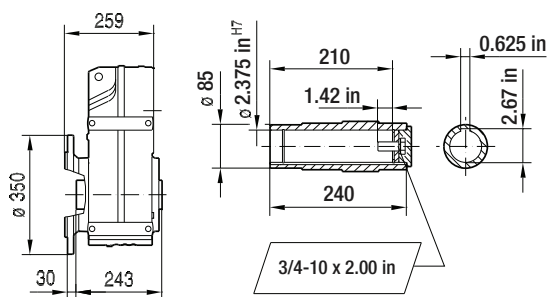

FVF87..

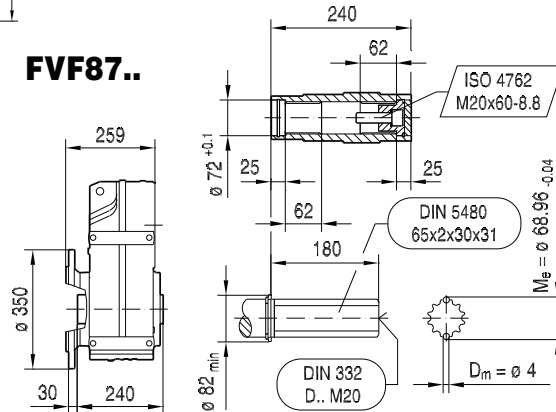

FHF87..

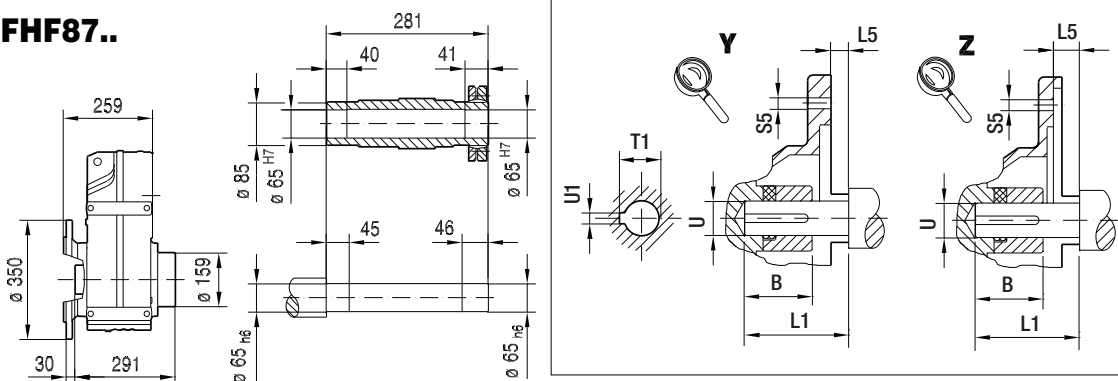

(→ 132)	B	B5	C5	E5	F5	G5	L	L1	L5	S5	T1	U	U1	Z5
AM143	1.68 in	4.50 in	12	5.875 in	4.5	170	473	2.25 in	0.13 in	10.5	0.98 in	0.875 in	0.188 in	98.5
AM145	1.68 in	4.50 in	12	5.875 in	4.5	170	473	2.25 in	0.13 in	10.5	0.98 in	0.875 in	0.188 in	98.5
AM182	2.10 in	8.50 in	10	7.25 in	5	228	509	2.75 in	0.13 in	15	1.24 in	1.125 in	0.250 in	134.5
AM184	2.10 in	8.50 in	10	7.25 in	5	228	509	2.75 in	0.13 in	15	1.24 in	1.125 in	0.250 in	134.5
AM213/215	2.76 in	8.50 in	11	7.25 in	5	228	558	3.38 in	0.25 in	15	1.52 in	1.375 in	0.312 in	183.5
AM254/256	3.65 in	8.50 in	14	7.25 in	5	228	608	4.00 in	0.25 in	15	1.80 in	1.625 in	0.375 in	234
AM284/286	4.00 in	10.50 in	15	9.00 in	5	286	615	4.62 in	0.25 in	15	2.10 in	1.875 in	0.500 in	241

Note: Dimensions in mm unless otherwise noted. For all available output shaft diameters, see page 409. For dimensions of compound gear units (ex: FF87R57) see page 401.

FA87..

42 035 00 11

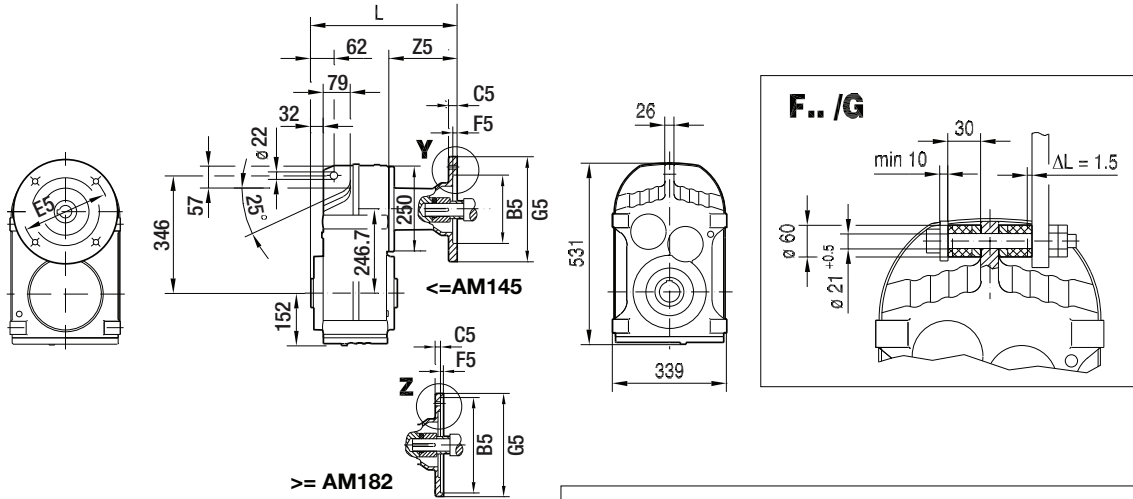

FA87..

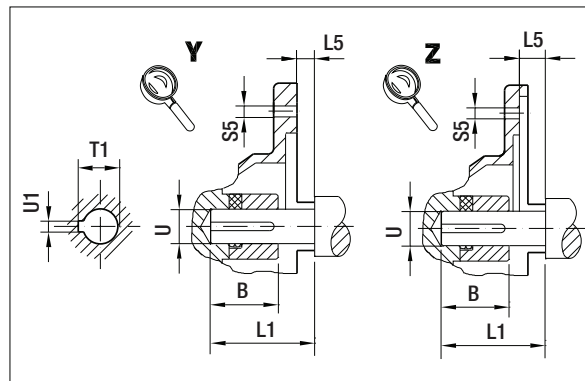
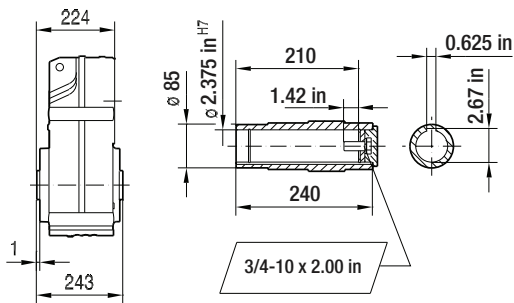

FH87..

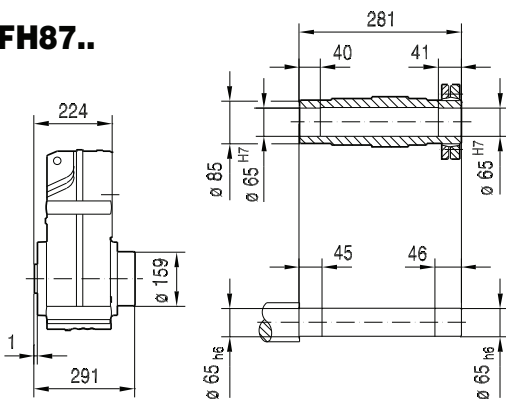

FV87..

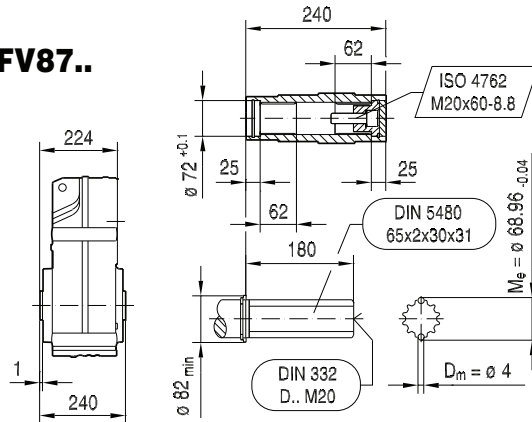

(→ 132)	B	B5	C5	E5	F5	G5	L	L1	L5	S5	T1	U	U1	Z5
AM143	1.68 in	4.50 in	12	5.875 in	4.5	170	443	2.25 in	0.13 in	10.5	0.98 in	0.875 in	0.188 in	98.5
AM145	1.68 in	4.50 in	12	5.875 in	4.5	170	443	2.25 in	0.13 in	10.5	0.98 in	0.875 in	0.188 in	98.5
AM182	2.10 in	8.50 in	10	7.25 in	5	228	479	2.75 in	0.13 in	15	1.24 in	1.125 in	0.250 in	134.5
AM184	2.10 in	8.50 in	10	7.25 in	5	228	479	2.75 in	0.13 in	15	1.24 in	1.125 in	0.250 in	134.5
AM213/215	2.76 in	8.50 in	11	7.25 in	5	228	528	3.38 in	0.25 in	15	1.52 in	1.375 in	0.312 in	183.5
AM254/256	3.65 in	8.50 in	14	7.25 in	5	228	578	4.00 in	0.25 in	15	1.80 in	1.625 in	0.375 in	234
AM284/286	4.00 in	10.50 in	15	9.00 in	5	286	585	4.62 in	0.25 in	15	2.10 in	1.875 in	0.500 in	241

Note: Dimensions in mm unless otherwise noted. For all available output shaft diameters, see page 411. For dimensions of compound gear units (ex: FA87R57) see page 401.

9 F - theSnuggler® Helical

F.. AM.. [NEMA dimensions]

FAZ87..

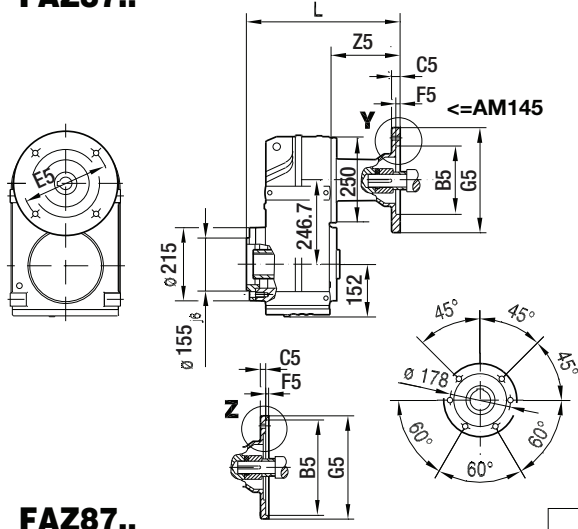

42 036 00 11

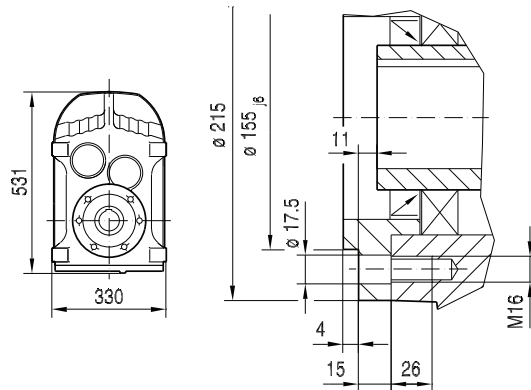

FAZ87..

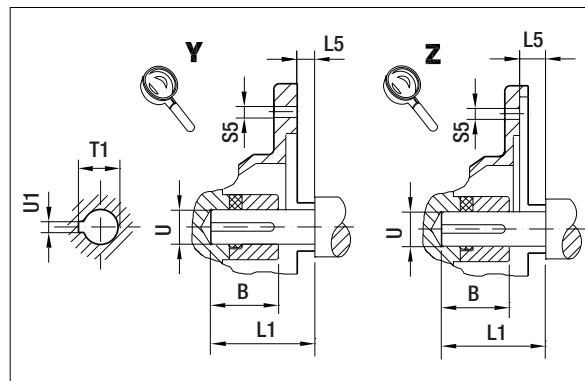
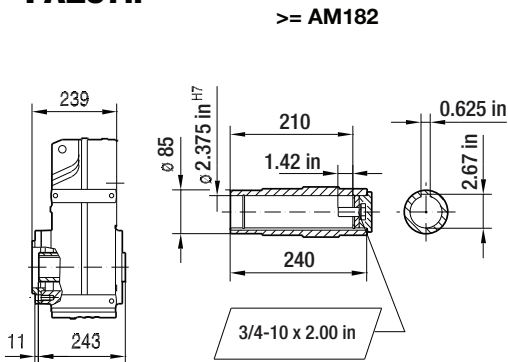

FHZ87..

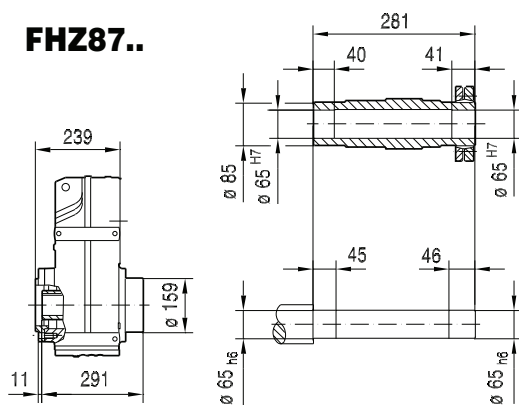

FVZ87..

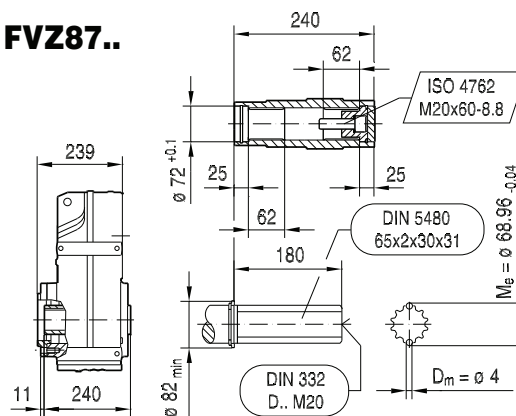

(→ 132)	B	B5	C5	E5	F5	G5	L	L1	L5	S5	T1	U	U1	Z5
AM143	1.68 in	4.50 in	12	5.875 in	4.5	170	338	2.25 in	0.13 in	10.5	0.98 in	0.875 in	0.188 in	98.5
AM145	1.68 in	4.50 in	12	5.875 in	4.5	170	338	2.25 in	0.13 in	10.5	0.98 in	0.875 in	0.188 in	98.5
AM182	2.10 in	8.50 in	10	7.25 in	5	228	374	2.75 in	0.13 in	15	1.24 in	1.125 in	0.250 in	134.5
AM184	2.10 in	8.50 in	10	7.25 in	5	228	374	2.75 in	0.13 in	15	1.24 in	1.125 in	0.250 in	134.5
AM213/215	2.76 in	8.50 in	11	7.25 in	5	228	423	3.38 in	0.25 in	15	1.52 in	1.375 in	0.312 in	183.5
AM254/256	3.65 in	8.50 in	14	7.25 in	5	228	473	4.00 in	0.25 in	15	1.80 in	1.625 in	0.375 in	234
AM284/286	4.00 in	10.50 in	15	9.00 in	5	286	480	4.62 in	0.25 in	15	2.10 in	1.875 in	0.500 in	241

Note: Dimensions in mm unless otherwise noted. For all available output shaft diameters, see page 411. For dimensions of compound gear units (ex: FAZ87R57) see page 401.

FT87..

42 037 00 11

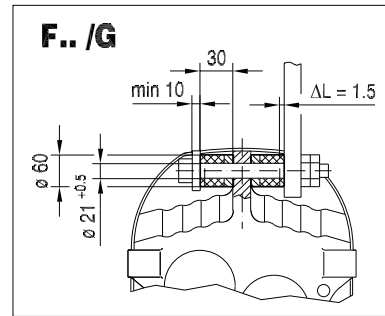
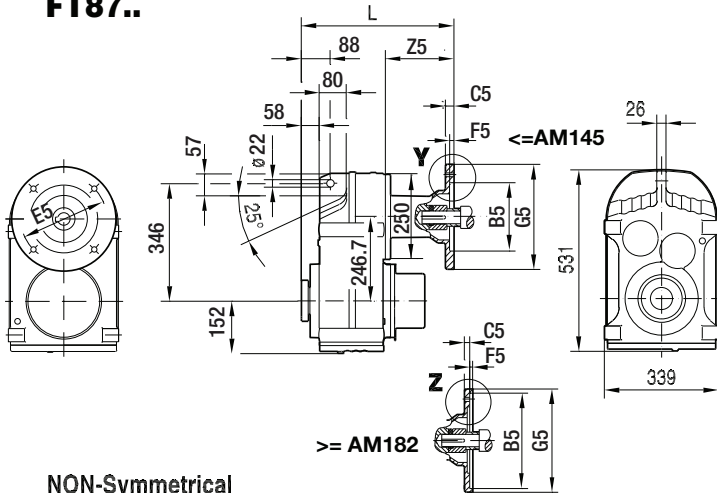

**NON-Symmetrical
FT87..**

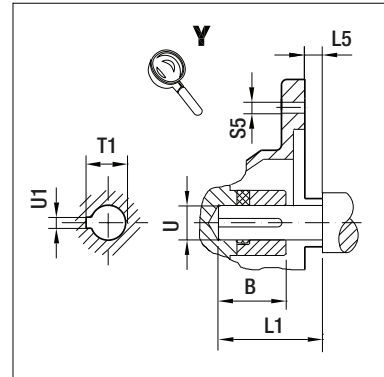
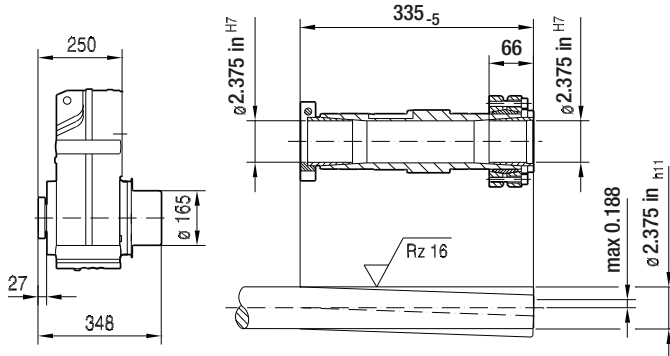

**Symmetrical
FT87..**

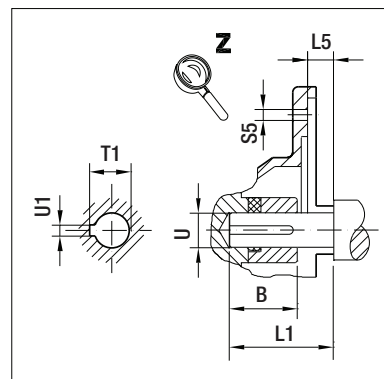
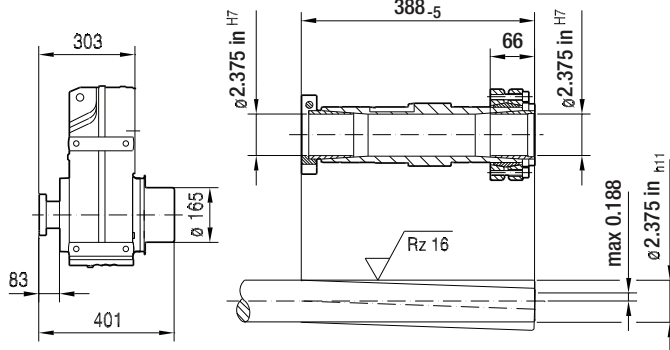

(→ 132)	B	B5	C5	E5	F5	G5	L	L1	L5	S5	T1	U	U1	Z5
AM143	1.68 in	4.50 in	12	5.875 in	4.5	170	443	2.25 in	0.13 in	10.5	0.98 in	0.875 in	0.188 in	98.5
AM145	1.68 in	4.50 in	12	5.875 in	4.5	170	443	2.25 in	0.13 in	10.5	0.98 in	0.875 in	0.188 in	98.5
AM182	2.10 in	8.50 in	10	7.25 in	5	228	479	2.75 in	0.13 in	15	1.24 in	1.125 in	0.250 in	134.5
AM184	2.10 in	8.50 in	10	7.25 in	5	228	479	2.75 in	0.13 in	15	1.24 in	1.125 in	0.250 in	134.5
AM213/215	2.76 in	8.50 in	11	7.25 in	5	228	528	3.38 in	0.25 in	15	1.52 in	1.375 in	0.312 in	183.5
AM254/256	3.65 in	8.50 in	14	7.25 in	5	228	578	4.00 in	0.25 in	15	1.80 in	1.625 in	0.375 in	234
AM284/286	4.00 in	10.50 in	15	9.00 in	5	286	585	4.62 in	0.25 in	15	2.10 in	1.875 in	0.500 in	241

Note: Dimensions in mm unless otherwise noted. For all available output shaft diameters, see page 413. For dimensions of compound gear units (ex: FT87R57) see page 401.

9 F - theSnuggler® Helical

F.. AM.. [NEMA dimensions]

F97..

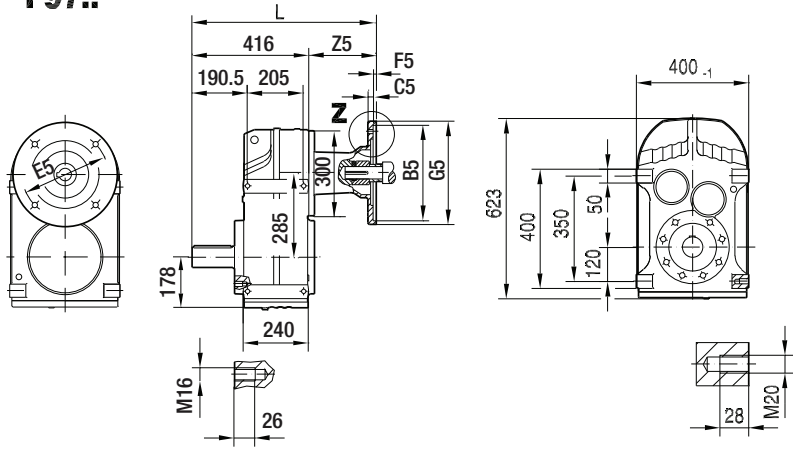

42 038 00 11

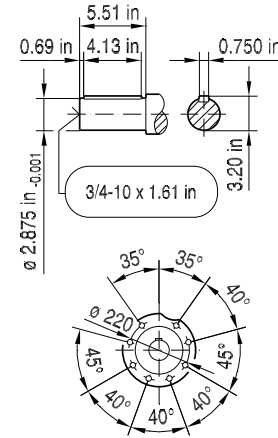

FA97B..

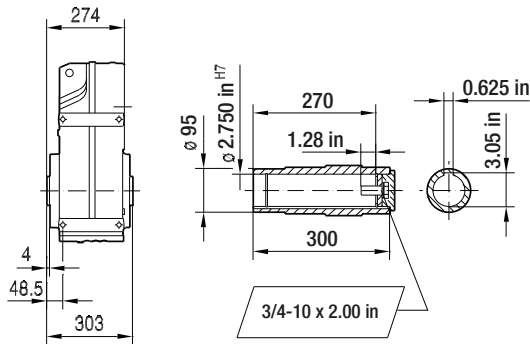

FV97B..

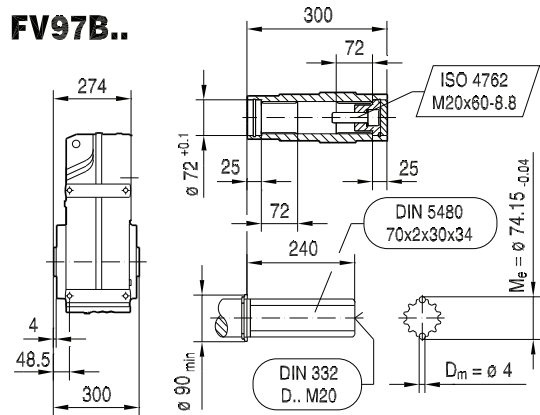

FH97B..

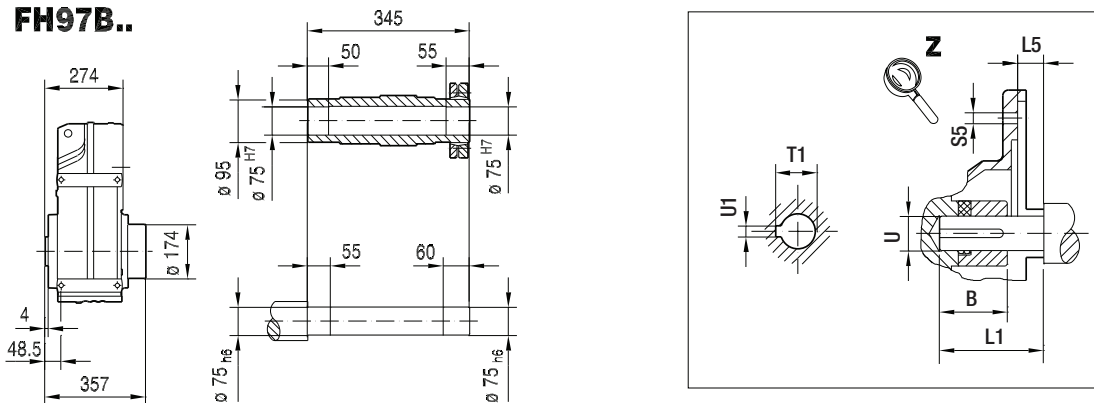

(→ 132)	B	B5	C5	E5	F5	G5	L	L1	L5	S5	T1	U	U1	Z5
AM182	2.10 in	8.50 in	10	7.25 in	5	228	546	2.75 in	0.13 in	15	1.24 in	1.125 in	0.250 in	129.5
AM184	2.10 in	8.50 in	10	7.25 in	5	228	546	2.75 in	0.13 in	15	1.24 in	1.125 in	0.250 in	129.5
AM213/215	2.76 in	8.50 in	11	7.25 in	5	228	595	3.38 in	0.25 in	15	1.52 in	1.375 in	0.312 in	178.5
AM254/256	3.65 in	8.50 in	12	7.25 in	5	228	645	4.00 in	0.25 in	15	1.80 in	1.625 in	0.375 in	229
AM284/286	4.00 in	10.50 in	15	9.00 in	5	286	652	4.62 in	0.25 in	15	2.10 in	1.875 in	0.500 in	236
AM324/326	3.88 in	12.50 in	17	11.0 in	5	356	712	5.25 in	0.25 in	17.5	2.36 in	2.125 in	0.500 in	296
AM364/365	4.51 in	12.50 in	17	11.0 in	5	356	712	5.88 in	0.25 in	17.5	2.66 in	2.375 in	0.625 in	296

Note: Dimensions in mm unless otherwise noted. For all available output shaft diameters, see page 409. For dimensions of compound gear units (ex: F97R57) see page 401.

FF97..

42 039 00 11

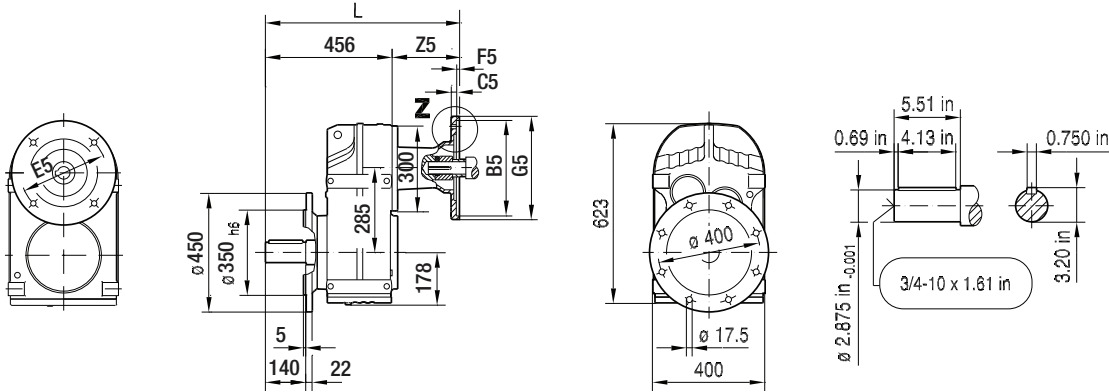

FAF97..

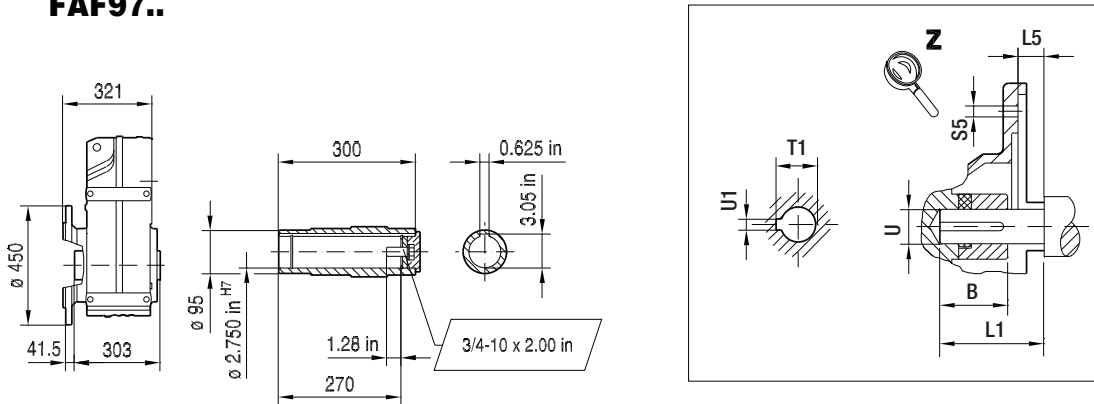

FHF97..

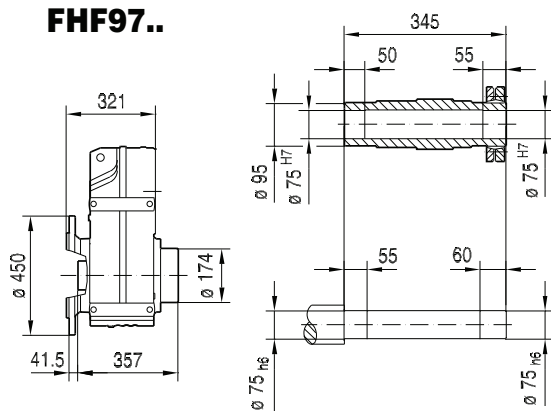

FVF97..

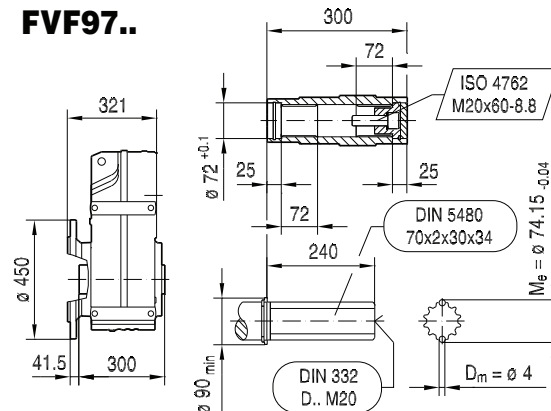

(→ 132)	B	B5	C5	E5	F5	G5	L	L1	L5	S5	T1	U	U1	Z5
AM182	2.10 in	8.50 in	10	7.25 in	5	228	586	2.75 in	0.13 in	15	1.24 in	1.125 in	0.250 in	129.5
AM184	2.10 in	8.50 in	10	7.25 in	5	228	586	2.75 in	0.13 in	15	1.24 in	1.125 in	0.250 in	129.5
AM213/215	2.76 in	8.50 in	11	7.25 in	5	228	635	3.38 in	0.25 in	15	1.52 in	1.375 in	0.312 in	178.5
AM254/256	3.65 in	8.50 in	12	7.25 in	5	228	685	4.00 in	0.25 in	15	1.80 in	1.625 in	0.375 in	229
AM284/286	4.00 in	10.50 in	15	9.00 in	5	286	692	4.62 in	0.25 in	15	2.10 in	1.875 in	0.500 in	236
AM324/326	3.88 in	12.50 in	17	11.0 in	5	356	752	5.25 in	0.25 in	17.5	2.36 in	2.125 in	0.500 in	296
AM364/365	4.51 in	12.50 in	17	11.0 in	5	356	752	5.88 in	0.25 in	17.5	2.66 in	2.375 in	0.625 in	296

Note: Dimensions in mm unless otherwise noted. For all available output shaft diameters, see page 409. For dimensions of compound gear units (ex: FAF97R57) see page 401.

9 F - theSnuggler® Helical

F.. AM.. [NEMA dimensions]

42 040 00 11

FA97..

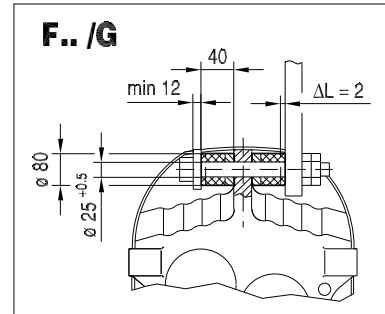
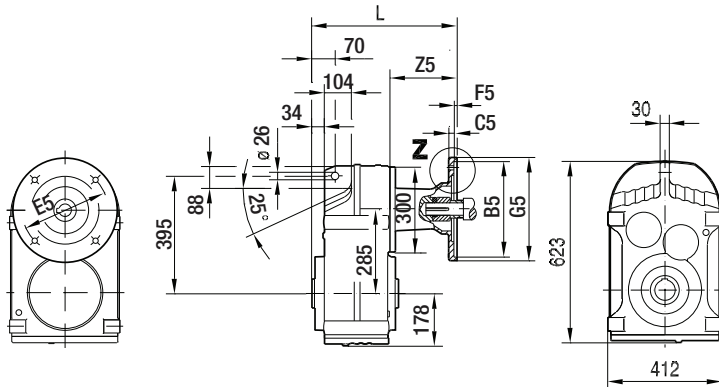

FA97..

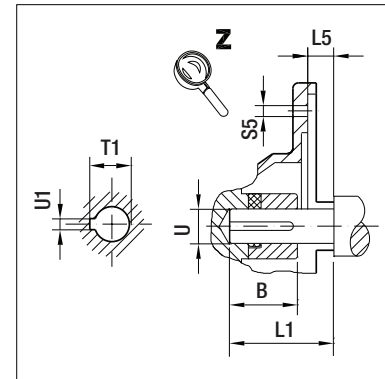
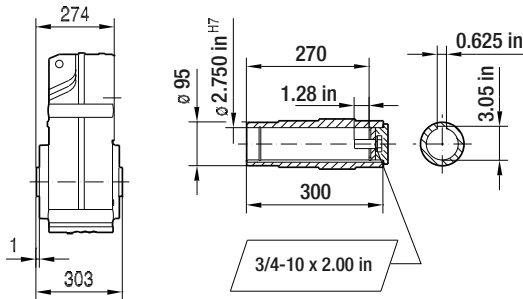

FH97..

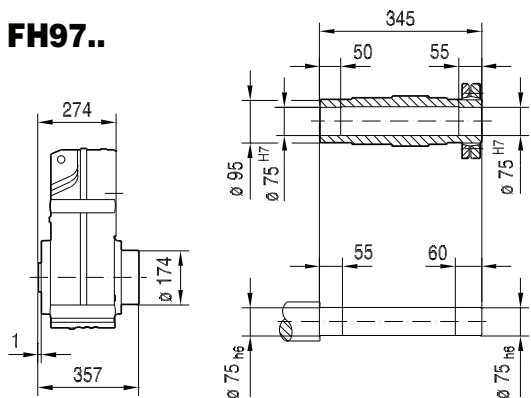

FV97..

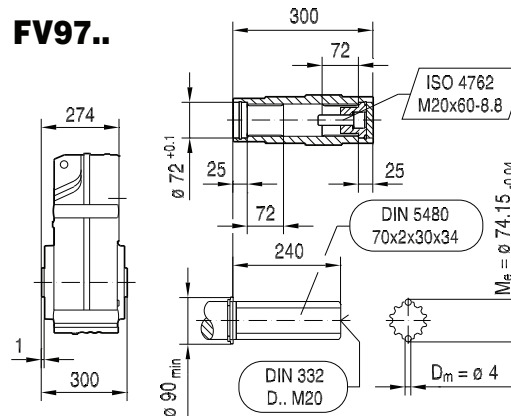

(→ 132)	B	B5	C5	E5	F5	G5	L	L1	L5	S5	T1	U	U1	Z5
AM182	2.10 in	8.50 in	10	7.25 in	5	228	404	2.75 in	0.13 in	15	1.24 in	1.125 in	0.250 in	129.5
AM184	2.10 in	8.50 in	10	7.25 in	5	228	404	2.75 in	0.13 in	15	1.24 in	1.125 in	0.250 in	129.5
AM213/215	2.76 in	8.50 in	11	7.25 in	5	228	453	3.38 in	0.25 in	15	1.52 in	1.375 in	0.312 in	178.5
AM254/256	3.65 in	8.50 in	12	7.25 in	5	228	503	4.00 in	0.25 in	15	1.80 in	1.625 in	0.375 in	229
AM284/286	4.00 in	10.50 in	15	9.00 in	5	286	510	4.62 in	0.25 in	15	2.10 in	1.875 in	0.500 in	236
AM324/326	3.88 in	12.50 in	17	11.0 in	5	356	570	5.25 in	0.25 in	17.5	2.36 in	2.125 in	0.500 in	296
AM364/365	4.51 in	12.50 in	17	11.0 in	5	356	570	5.88 in	0.25 in	17.5	2.66 in	2.375 in	0.625 in	296

Note: Dimensions in mm unless otherwise noted. For all available output shaft diameters, see page 411. For dimensions of compound gear units (ex: FA97R57) see page 401.

FAZ97..

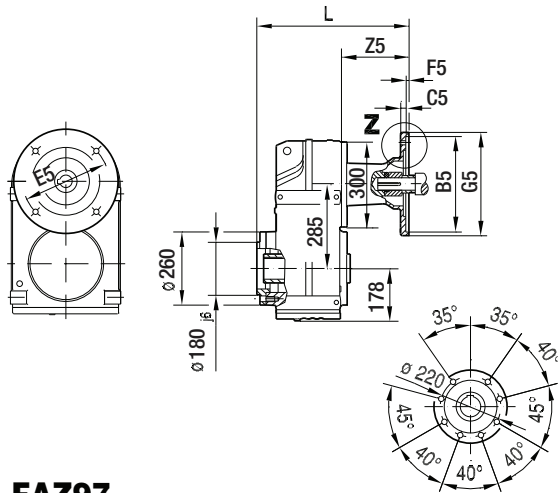

42 041 00 11

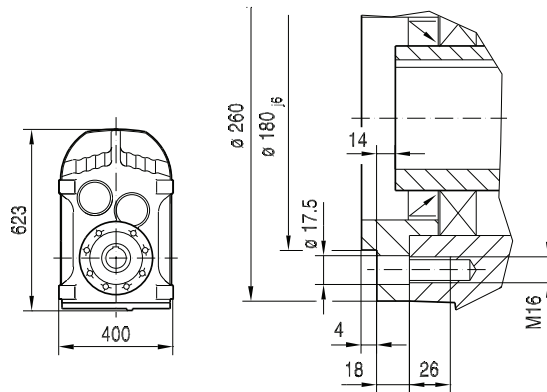

FAZ97..

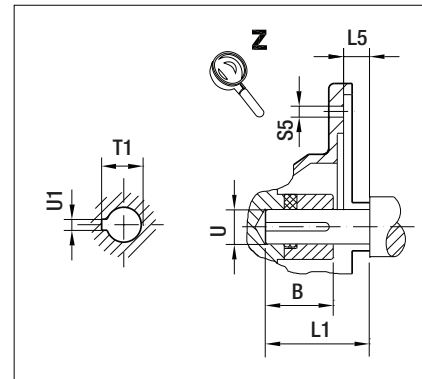
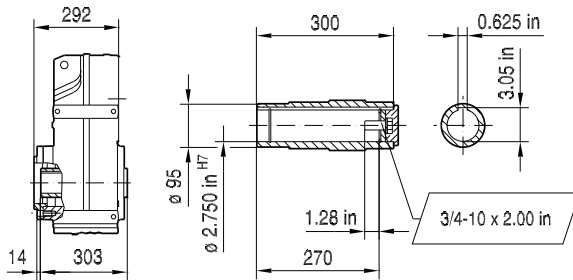

FHZ97..

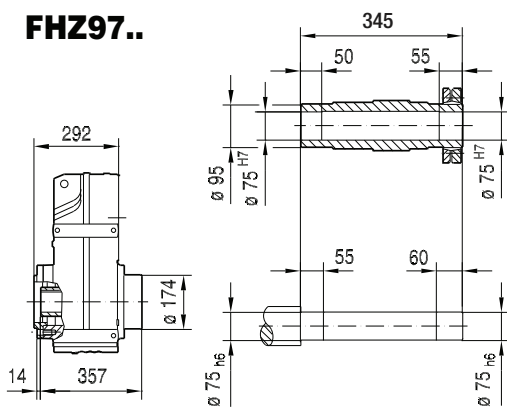

FVZ97..

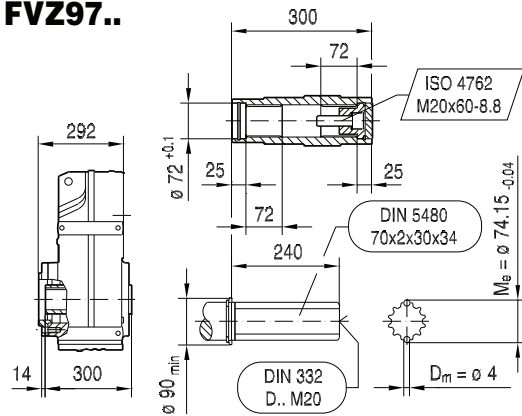

(→ 132)	B	B5	C5	E5	F5	G5	L	L1	L5	S5	T1	U	U1	Z5
AM182	2.10 in	8.50 in	10	7.25 in	5	228	422	2.75 in	0.13 in	15	1.24 in	1.125 in	0.250 in	129.5
AM184	2.10 in	8.50 in	10	7.25 in	5	228	422	2.75 in	0.13 in	15	1.24 in	1.125 in	0.250 in	129.5
AM213/215	2.76 in	8.50 in	11	7.25 in	5	228	471	3.38 in	0.25 in	15	1.52 in	1.375 in	0.312 in	178.5
AM254/256	3.65 in	8.50 in	12	7.25 in	5	228	521	4.00 in	0.25 in	15	1.80 in	1.625 in	0.375 in	229
AM284/286	4.00 in	10.50 in	15	9.00 in	5	286	528	4.62 in	0.25 in	15	2.10 in	1.875 in	0.500 in	236
AM324/326	3.88 in	12.50 in	17	11.0 in	5	356	588	5.25 in	0.25 in	17.5	2.36 in	2.125 in	0.500 in	296
AM364/365	4.51 in	12.50 in	17	11.0 in	5	356	588	5.88 in	0.25 in	17.5	2.66 in	2.375 in	0.625 in	296

Note: Dimensions in mm unless otherwise noted. For all available output shaft diameters, see page 411. For dimensions of compound gear units (ex: FAZ97R57) see page 401.

9 F - theSnuggler® Helical

F.. AM.. [NEMA dimensions]

FT97..

42 042 00 11

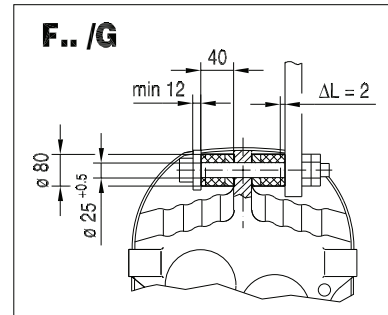
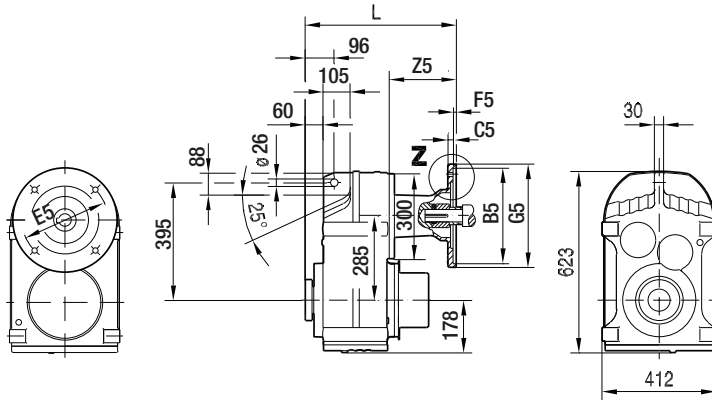

NON-Symmetrical FT97..

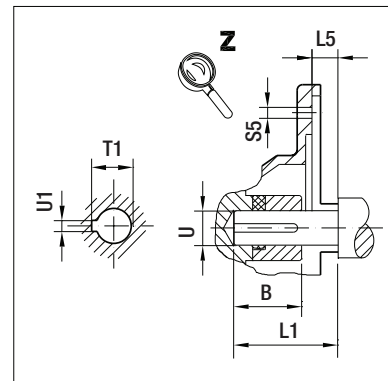
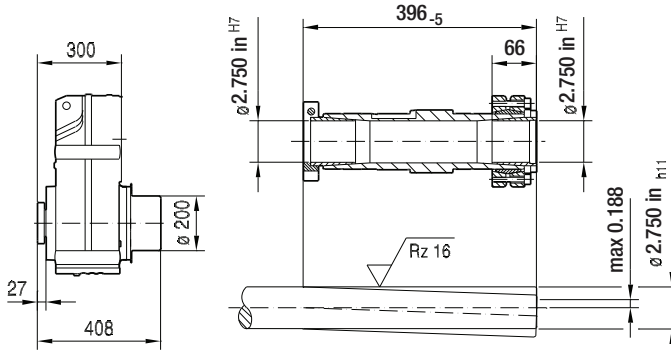

Symmetrical FT97..

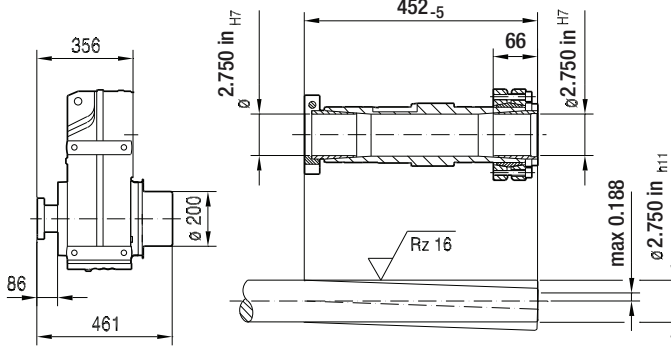

(→ 132)	B	B5	C5	E5	F5	G5	L	L1	L5	S5	T1	U	U1	Z5
AM182	2.10 in	8.50 in	10	7.25 in	5	228	430	2.75 in	0.13 in	15	1.24 in	1.125 in	0.250 in	129.5
AM184	2.10 in	8.50 in	10	7.25 in	5	228	430	2.75 in	0.13 in	15	1.24 in	1.125 in	0.250 in	129.5
AM213/215	2.76 in	8.50 in	11	7.25 in	5	228	479	3.38 in	0.25 in	15	1.52 in	1.375 in	0.312 in	178.5
AM254/256	3.65 in	8.50 in	12	7.25 in	5	228	529	4.00 in	0.25 in	15	1.80 in	1.625 in	0.375 in	229
AM284/286	4.00 in	10.50 in	15	9.00 in	5	286	536	4.62 in	0.25 in	15	2.10 in	1.875 in	0.500 in	236
AM324/326	3.88 in	12.50 in	17	11.0 in	5	356	596	5.25 in	0.25 in	17.5	2.36 in	2.125 in	0.500 in	296
AM364/365	4.51 in	12.50 in	17	11.0 in	5	356	596	5.88 in	0.25 in	17.5	2.66 in	2.375 in	0.625 in	296

Note: Dimensions in mm unless otherwise noted. For all available output shaft diameters, see page 413. For dimensions of compound gear units (ex: FT97R57) see page 401.

F107..

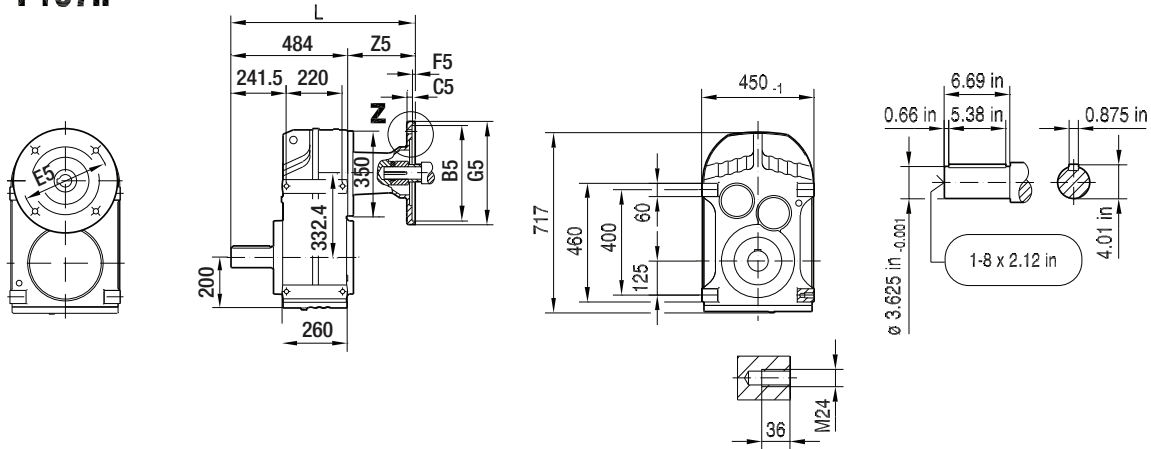

42 043 00 11

FA107B..

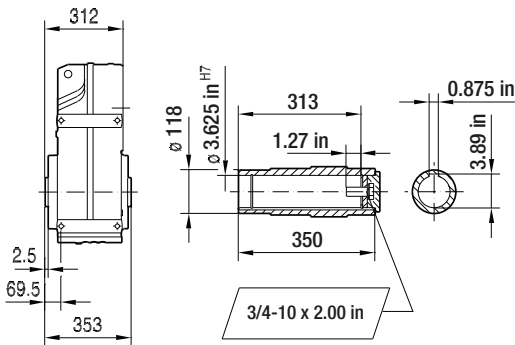

FV107B..

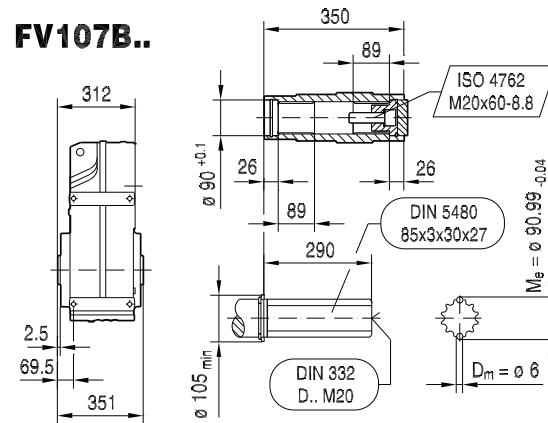

FH107B..

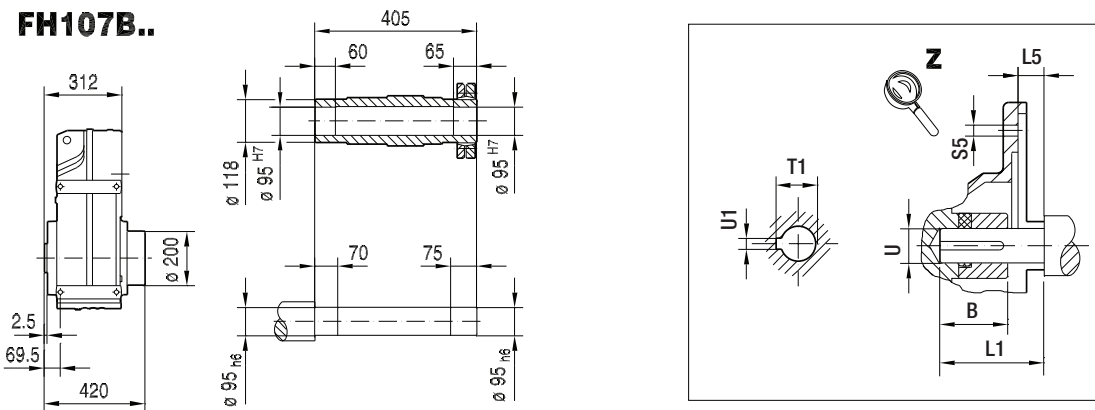

(→ 132)	B	B5	C5	E5	F5	G5	L	L1	L5	S5	T1	U	U1	Z5
AM182	2.10 in	8.50 in	10	7.25 in	5	228	608	2.75 in	0.13 in	15	1.24 in	1.125 in	0.250 in	123.5
AM184	2.10 in	8.50 in	10	7.25 in	5	228	608	2.75 in	0.13 in	15	1.24 in	1.125 in	0.250 in	123.5
AM213/215	2.76 in	8.50 in	11	7.25 in	5	228	657	3.38 in	0.25 in	15	1.52 in	1.375 in	0.312 in	172.5
AM254/256	3.65 in	8.50 in	12	7.25 in	5	228	707	4.00 in	0.25 in	15	1.80 in	1.625 in	0.375 in	223
AM284/286	4.00 in	10.50 in	15	9.00 in	5	286	714	4.62 in	0.25 in	15	2.10 in	1.875 in	0.500 in	230
AM324/326	3.88 in	12.50 in	17	11.0 in	5	356	774	5.25 in	0.25 in	17.5	2.36 in	2.125 in	0.500 in	290
AM364/365	4.51 in	12.50 in	17	11.0 in	5	356	774	5.88 in	0.25 in	17.5	2.66 in	2.375 in	0.625 in	290

Note: Dimensions in mm unless otherwise noted. For all available output shaft diameters, see page 409. For dimensions of compound gear units (ex: F107R77) see page 401.

9 F - theSnuggler® Helical

F.. AM.. [NEMA dimensions]

FF107..

42 044 00 11

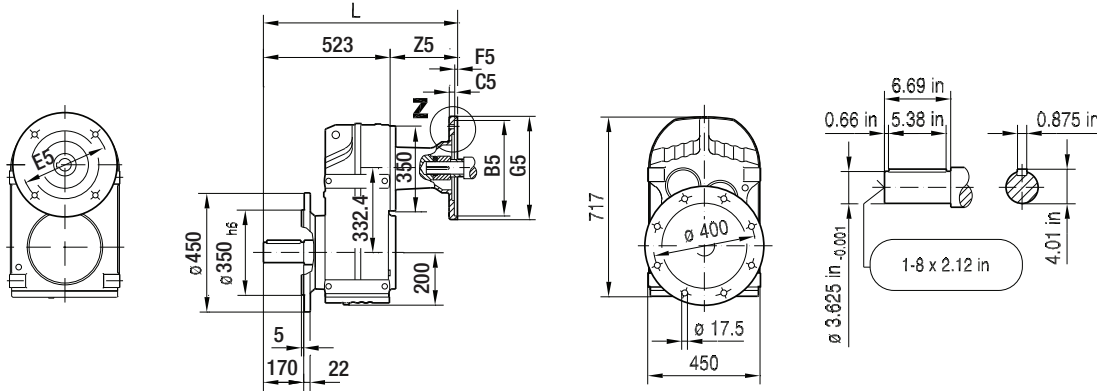

FAF107..

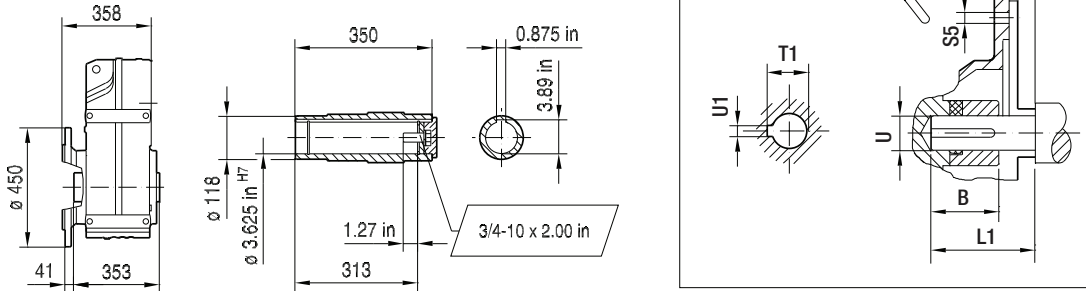

FHF107..

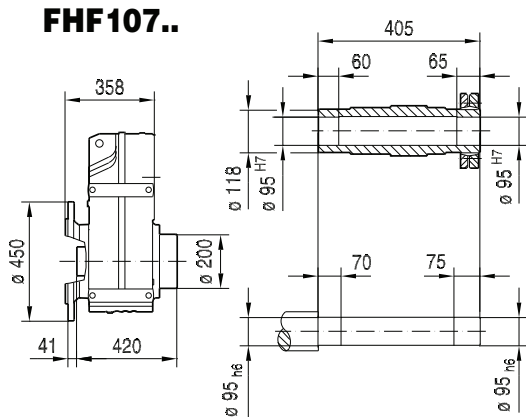

FVF107..

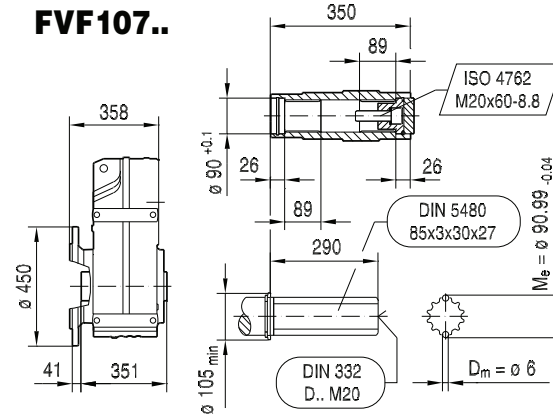

(→ 132)	B	B5	C5	E5	F5	G5	L	L1	L5	S5	T1	U	U1	Z5
AM182	2.10 in	8.50 in	10	7.25 in	5	228	647	2.75 in	0.13 in	15	1.24 in	1.125 in	0.250 in	123.5
AM184	2.10 in	8.50 in	10	7.25 in	5	228	647	2.75 in	0.13 in	15	1.24 in	1.125 in	0.250 in	123.5
AM213/215	2.76 in	8.50 in	11	7.25 in	5	228	696	3.38 in	0.25 in	15	1.52 in	1.375 in	0.312 in	172.5
AM254/256	3.65 in	8.50 in	12	7.25 in	5	228	746	4.00 in	0.25 in	15	1.80 in	1.625 in	0.375 in	223
AM284/286	4.00 in	10.50 in	15	9.00 in	5	286	753	4.62 in	0.25 in	15	2.10 in	1.875 in	0.500 in	230
AM324/326	3.88 in	12.50 in	17	11.0 in	5	356	813	5.25 in	0.25 in	17.5	2.36 in	2.125 in	0.500 in	290
AM364/365	4.51 in	12.50 in	17	11.0 in	5	356	813	5.88 in	0.25 in	17.5	2.66 in	2.375 in	0.625 in	290

Note: Dimensions in mm unless otherwise noted. For all available output shaft diameters, see page 409. For dimensions of compound gear units (ex: FF107R77) see page 401.

FA107..

42 045 00 11

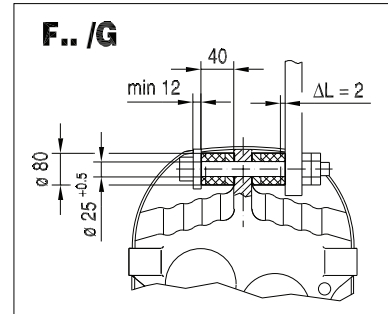
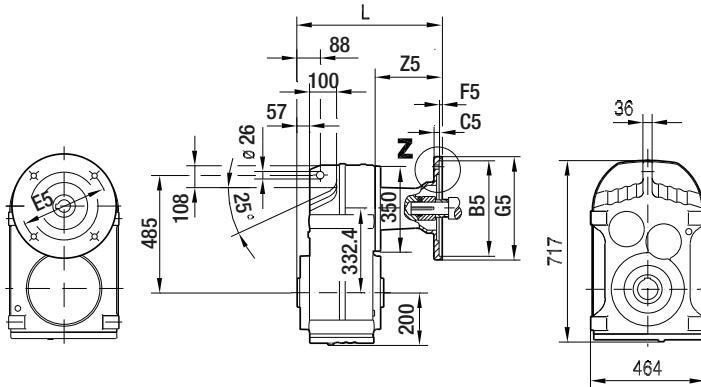

FA107..

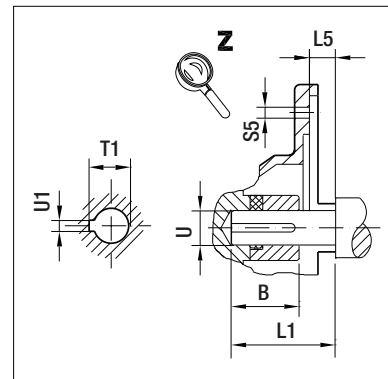
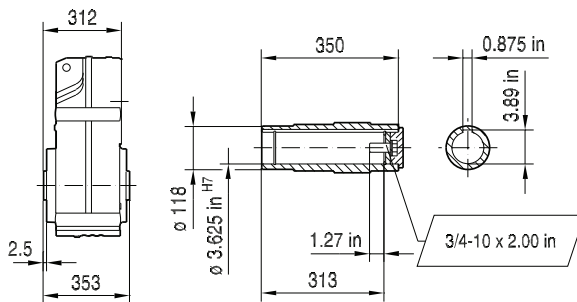

FH107..

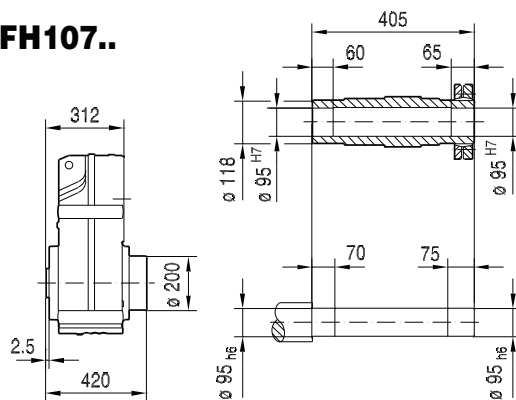

FV107..

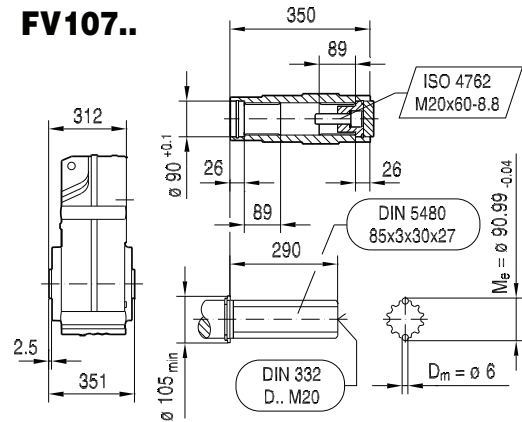

(→ 132)	B	B5	C5	E5	F5	G5	L	L1	L5	S5	T1	U	U1	Z5
AM182	2.10 in	8.50 in	10	7.25 in	5	228	436	2.75 in	0.13 in	15	1.24 in	1.125 in	0.250 in	123.5
AM184	2.10 in	8.50 in	10	7.25 in	5	228	436	2.75 in	0.13 in	15	1.24 in	1.125 in	0.250 in	123.5
AM213/215	2.76 in	8.50 in	11	7.25 in	5	228	485	3.38 in	0.25 in	15	1.52 in	1.375 in	0.312 in	172.5
AM254/256	3.65 in	8.50 in	12	7.25 in	5	228	535	4.00 in	0.25 in	15	1.80 in	1.625 in	0.375 in	223
AM284/286	4.00 in	10.50 in	15	9.00 in	5	286	542	4.62 in	0.25 in	15	2.10 in	1.875 in	0.500 in	230
AM324/326	3.88 in	12.50 in	17	11.0 in	5	356	602	5.25 in	0.25 in	17.5	2.36 in	2.125 in	0.500 in	290
AM364/365	4.51 in	12.50 in	17	11.0 in	5	356	602	5.88 in	0.25 in	17.5	2.66 in	2.375 in	0.625 in	290

Note: Dimensions in mm unless otherwise noted. For all available output shaft diameters, see page 411. For dimensions of compound gear units (ex: FA107R77) see page 401.

9 F - theSnuggler® Helical

F.. AM.. [NEMA dimensions]

FAZ107..

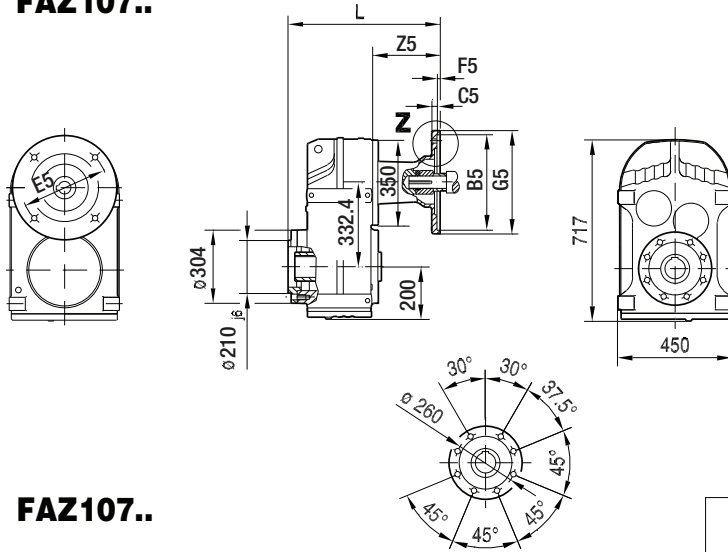

42 046 00 11

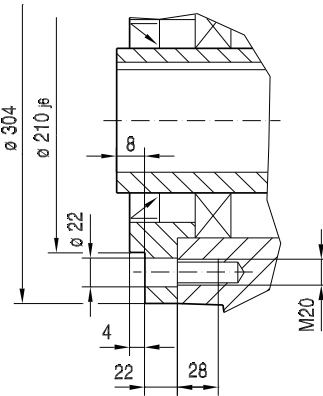

FAZ107..

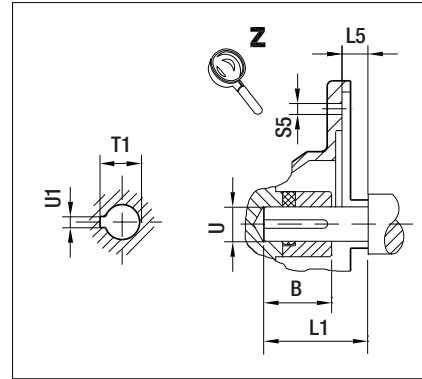
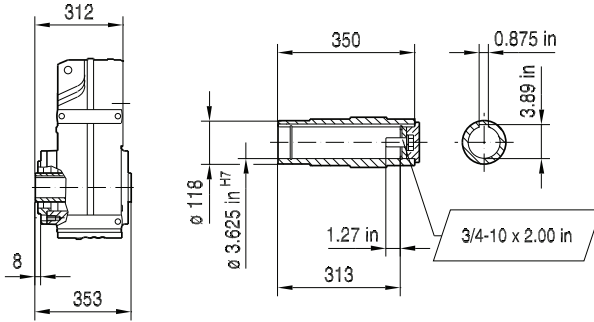

FHZ107..

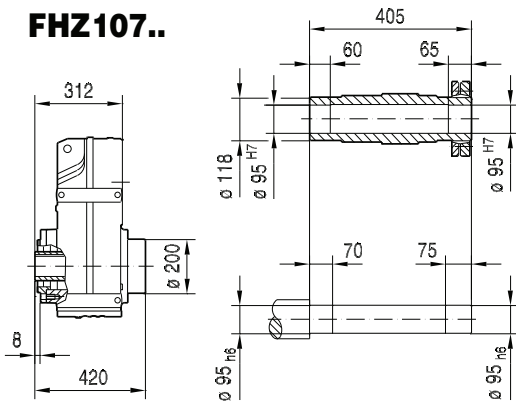

FVZ107..

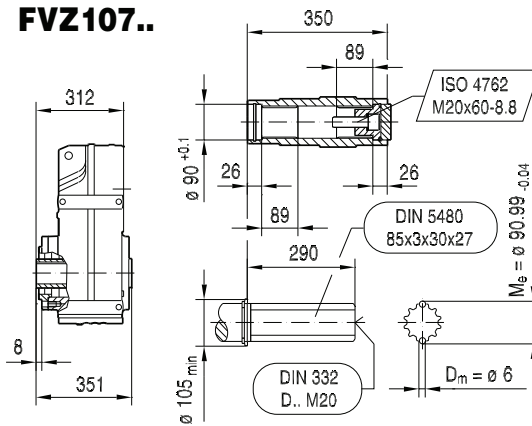

(→ 132)	B	B5	C5	E5	F5	G5	L	L1	L5	S5	T1	U	U1	Z5
AM182	2.10 in	8.50 in	10	7.25 in	5	228	436	2.75 in	0.13 in	15	1.24 in	1.125 in	0.250 in	123.5
AM184	2.10 in	8.50 in	10	7.25 in	5	228	436	2.75 in	0.13 in	15	1.24 in	1.125 in	0.250 in	123.5
AM213/215	2.76 in	8.50 in	11	7.25 in	5	228	485	3.38 in	0.25 in	15	1.52 in	1.375 in	0.312 in	172.5
AM254/256	3.65 in	8.50 in	12	7.25 in	5	228	535	4.00 in	0.25 in	15	1.80 in	1.625 in	0.375 in	223
AM284/286	4.00 in	10.50 in	15	9.00 in	5	286	542	4.62 in	0.25 in	15	2.10 in	1.875 in	0.500 in	230
AM324/326	3.88 in	12.50 in	17	11.0 in	5	356	602	5.25 in	0.25 in	17.5	2.36 in	2.125 in	0.500 in	290
AM364/365	4.51 in	12.50 in	17	11.0 in	5	356	602	5.88 in	0.25 in	17.5	2.66 in	2.375 in	0.625 in	290

Note: Dimensions in mm unless otherwise noted. For all available output shaft diameters, see page 411. For dimensions of compound gear units (ex: FAZ107R77) see page 401.

FT107..

42 047 00 11

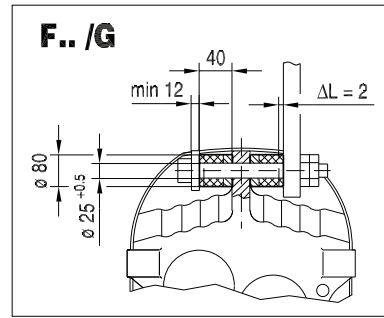
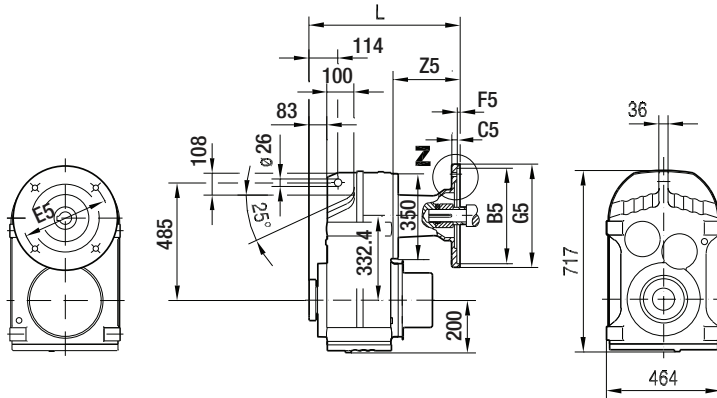

**NON-Symmetrical
FT107..**

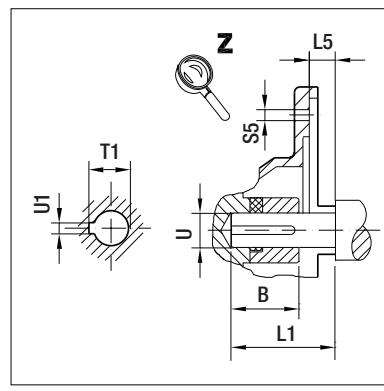
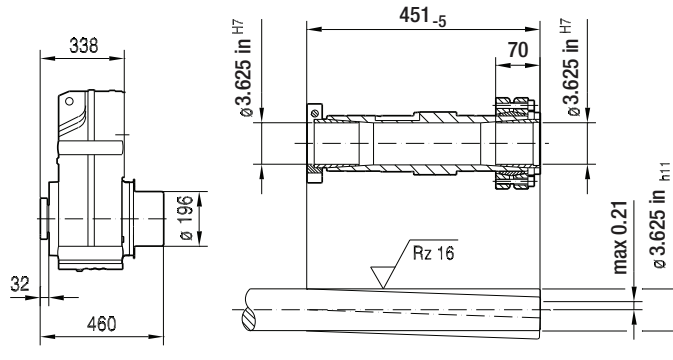

**Symmetrical
FT107..**

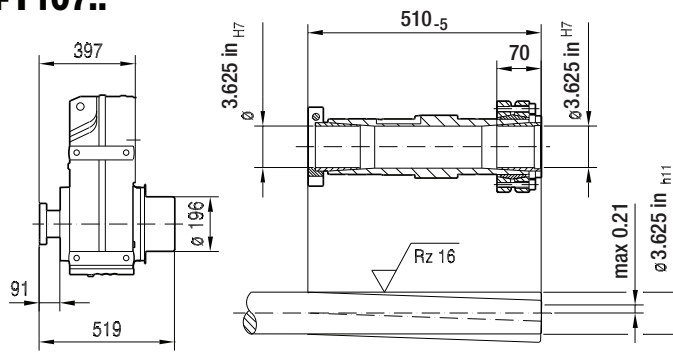

(→ 132)	B	B5	C5	E5	F5	G5	L	L1	L5	S5	T1	U	U1	Z5
AM182	2.10 in	8.50 in	10	7.25 in	5	228	462	2.75 in	0.13 in	15	1.24 in	1.125 in	0.250 in	123.5
AM184	2.10 in	8.50 in	10	7.25 in	5	228	462	2.75 in	0.13 in	15	1.24 in	1.125 in	0.250 in	123.5
AM213/215	2.76 in	8.50 in	11	7.25 in	5	228	511	3.38 in	0.25 in	15	1.52 in	1.375 in	0.312 in	172.5
AM254/256	3.65 in	8.50 in	12	7.25 in	5	228	561	4.00 in	0.25 in	15	1.80 in	1.625 in	0.375 in	223
AM284/286	4.00 in	10.50 in	15	9.00 in	5	286	568	4.62 in	0.25 in	15	2.10 in	1.875 in	0.500 in	230
AM324/326	3.88 in	12.50 in	17	11.0 in	5	356	628	5.25 in	0.25 in	17.5	2.36 in	2.125 in	0.500 in	290
AM364/365	4.51 in	12.50 in	17	11.0 in	5	356	628	5.88 in	0.25 in	17.5	2.66 in	2.375 in	0.625 in	290

Note: Dimensions in mm unless otherwise noted. For all available output shaft diameters, see page 413. For dimensions of compound gear units (ex: FT107R77) see page 401.

9 F - theSnuggler® Helical

F.. AM.. [NEMA dimensions]

42 048 00 11

F127..

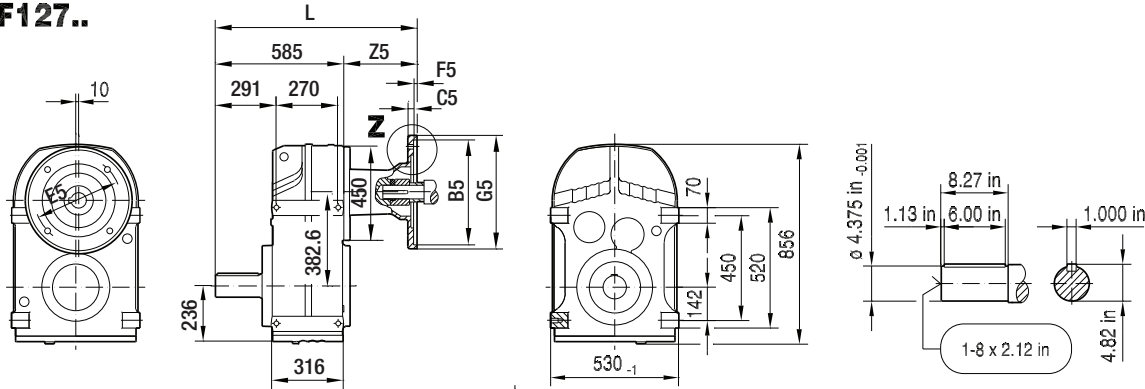

FA127B..

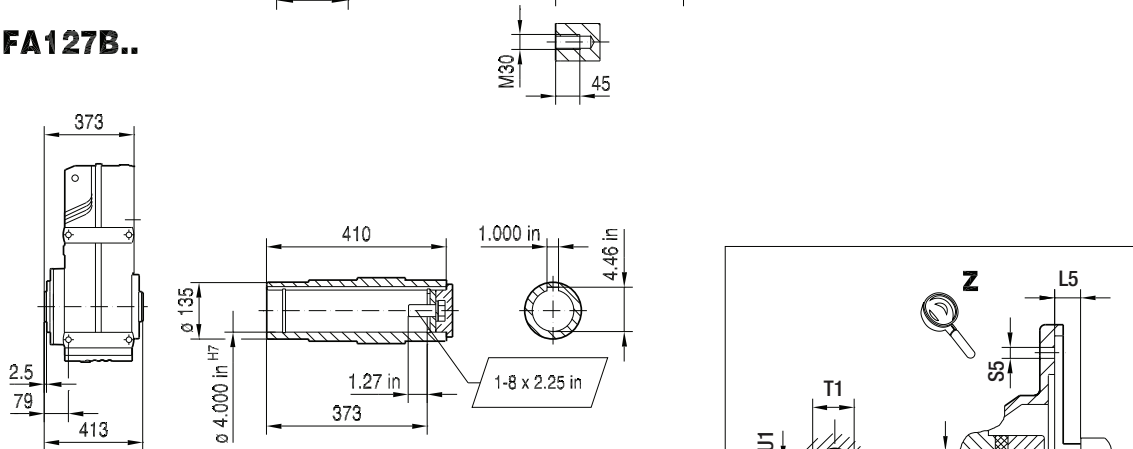

FH127B..

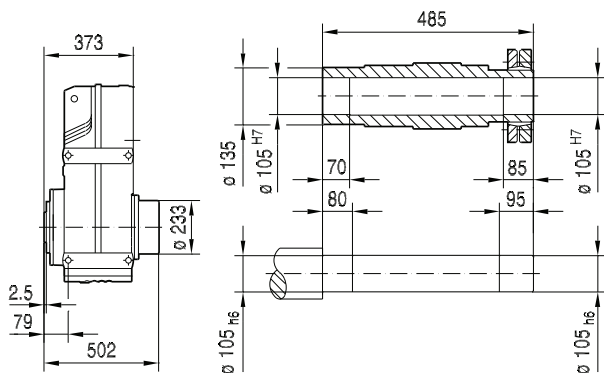

(→ 132)	B	B5	C5	E5	F5	G5	L	L1	L5	S5	T1	U	U1	Z5
AM213/215	2.76 in	8.50 in	11	7.25 in	5	228	743	3.38 in	0.25 in	15	1.52 in	1.375 in	0.312 in	157.5
AM254/256	3.65 in	8.50 in	12	7.25 in	5	228	793	4.00 in	0.25 in	15	1.80 in	1.625 in	0.375 in	208
AM284/286	4.00 in	10.50 in	15	9.00 in	5	286	800	4.62 in	0.25 in	15	2.10 in	1.875 in	0.500 in	215
AM324/326	3.88 in	12.50 in	17	11.0 in	5	356	860	5.25 in	0.25 in	17.5	2.36 in	2.125 in	0.500 in	275
AM364/365	4.51 in	12.50 in	17	11.0 in	5	356	860	5.88 in	0.25 in	17.5	2.66 in	2.375 in	0.625 in	275

Note: Dimensions in mm unless otherwise noted. For all available output shaft diameters, see page 409. For dimensions of compound gear units (ex: FA127R77) see page 401.

FF127..

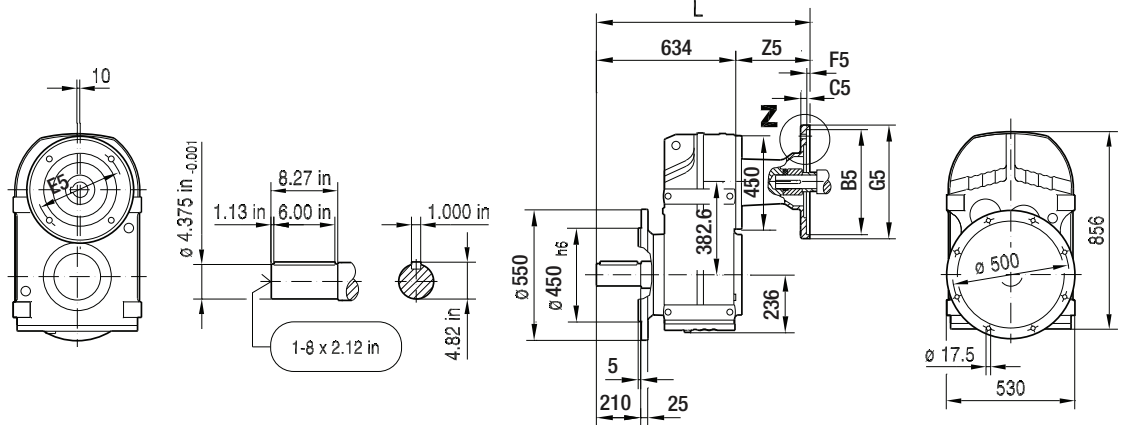

42 049 00 11

FAF127..

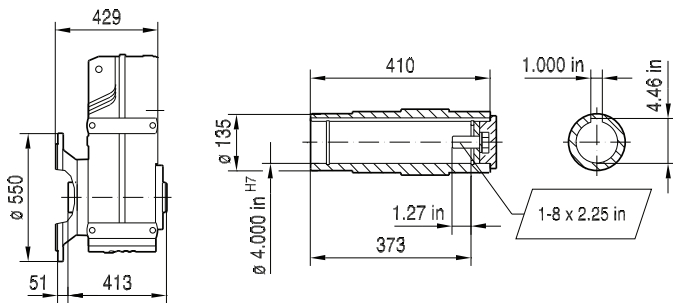

FHF127..

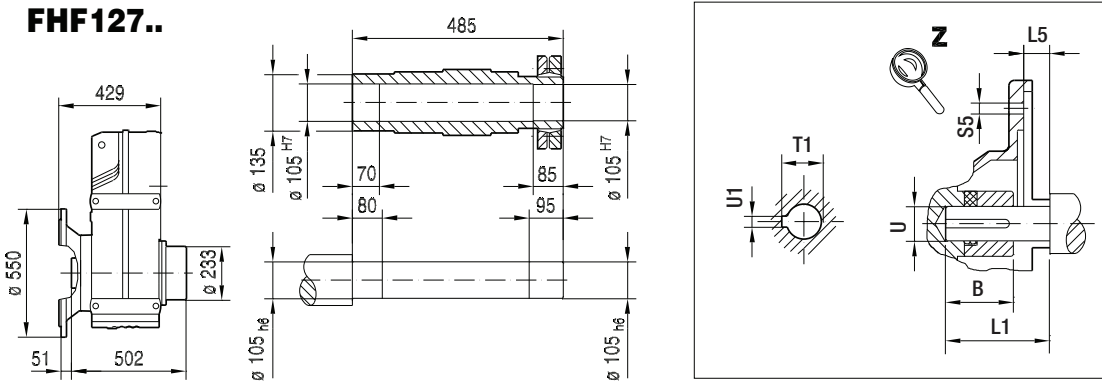

(→ 132)	B	B5	C5	E5	F5	G5	L	L1	L5	S5	T1	U	U1	Z5
AM213/215	2.76 in	8.50 in	11	7.25 in	5	228	792	3.38 in	0.25 in	15	1.52 in	1.375 in	0.312 in	157.5
AM254/256	3.65 in	8.50 in	12	7.25 in	5	228	842	4.00 in	0.25 in	15	1.80 in	1.625 in	0.375 in	208
AM284/286	4.00 in	10.50 in	15	9.00 in	5	286	849	4.62 in	0.25 in	15	2.10 in	1.875 in	0.500 in	215
AM324/326	3.88 in	12.50 in	17	11.0 in	5	356	909	5.25 in	0.25 in	17.5	2.36 in	2.125 in	0.500 in	275
AM364/365	4.51 in	12.50 in	17	11.0 in	5	356	909	5.88 in	0.25 in	17.5	2.66 in	2.375 in	0.625 in	275

Note: Dimensions in mm unless otherwise noted. For all available output shaft diameters, see page 409. For dimensions of compound gear units (ex: FAF127R77) see page 401.

9 F - theSnuggler® Helical

F.. AM.. [NEMA dimensions]

FA127..

42 050 00 11

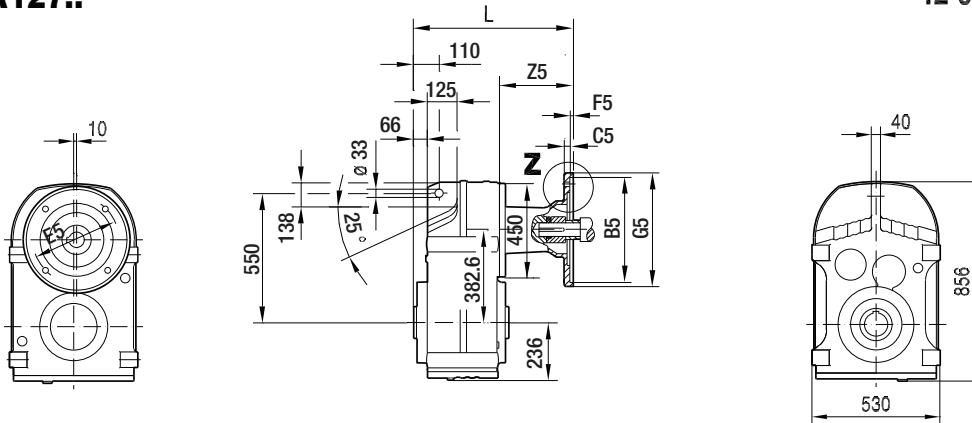

FA127..

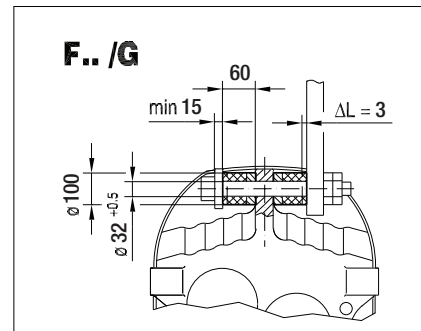
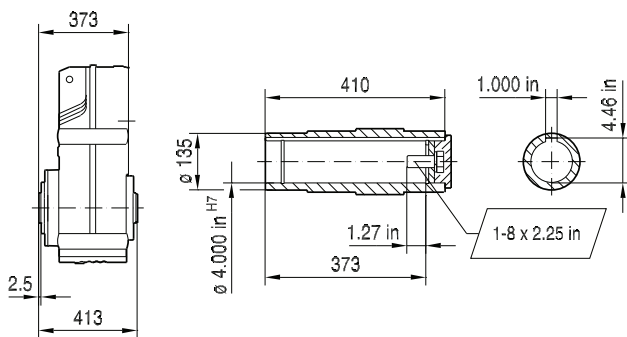

FH127..

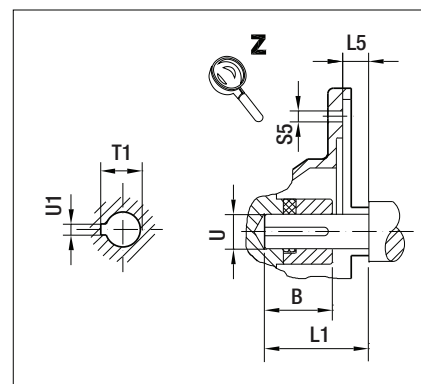
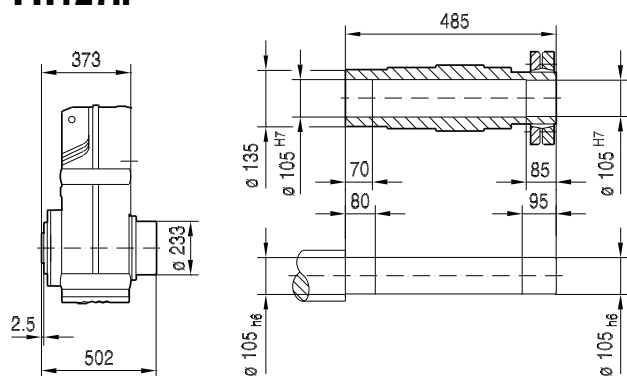

(→ 132)	B	B5	C5	E5	F5	G5	L	L1	L5	S5	T1	U	U1	Z5
AM213/215	2.76 in	8.50 in	11	7.25 in	5	228	531	3.38 in	0.25 in	15	1.52 in	1.375 in	0.312 in	157.5
AM254/256	3.65 in	8.50 in	12	7.25 in	5	228	581	4.00 in	0.25 in	15	1.80 in	1.625 in	0.375 in	208
AM284/286	4.00 in	10.50 in	15	9.00 in	5	286	588	4.62 in	0.25 in	15	2.10 in	1.875 in	0.500 in	215
AM324/326	3.88 in	12.50 in	17	11.0 in	5	356	648	5.25 in	0.25 in	17.5	2.36 in	2.125 in	0.500 in	275
AM364/365	4.51 in	12.50 in	17	11.0 in	5	356	648	5.88 in	0.25 in	17.5	2.66 in	2.375 in	0.625 in	275

Note: Dimensions in mm unless otherwise noted. For all available output shaft diameters, see page 411. For dimensions of compound gear units (ex: FA127R77) see page 401.

FAZ127..

42 051 00 11

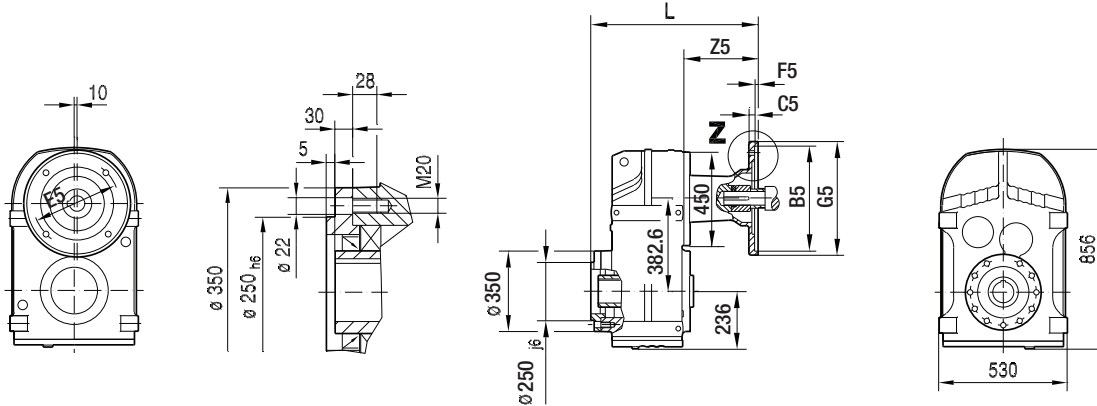

FAZ127..

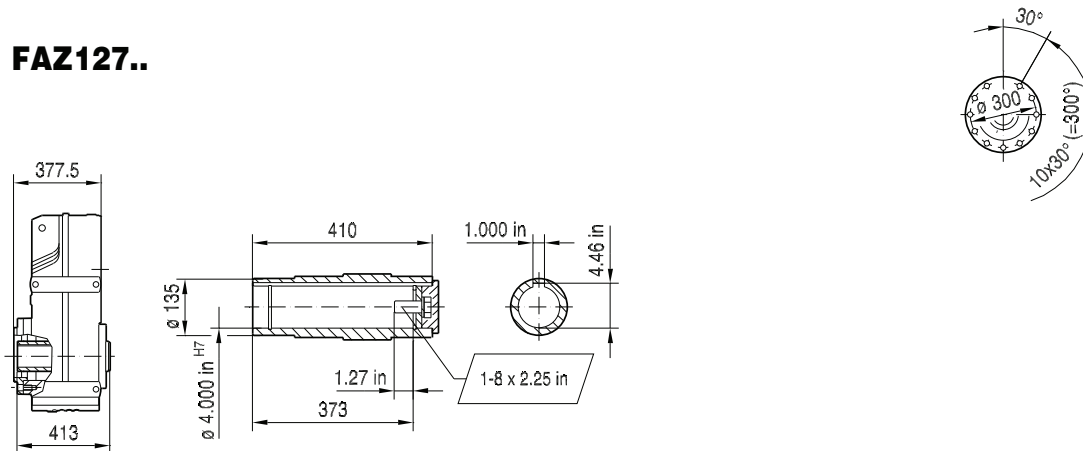

FHZ127..

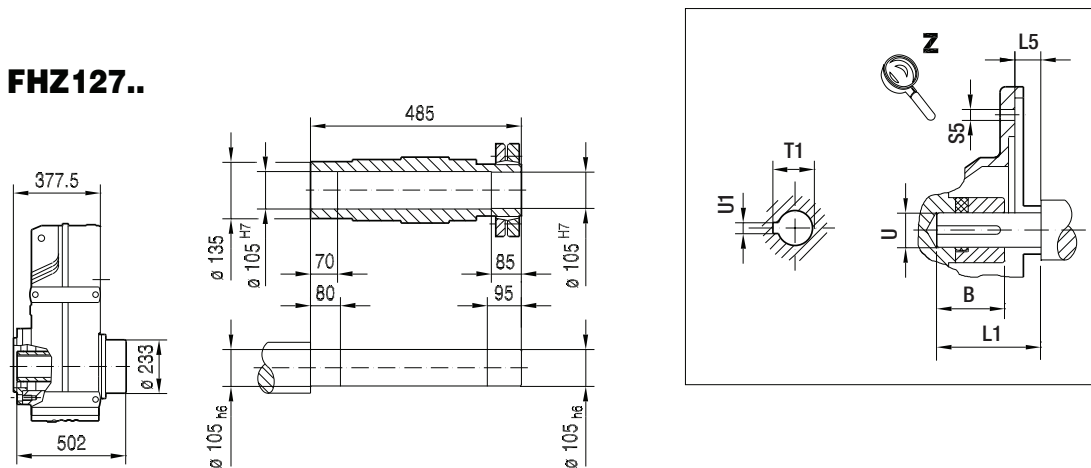

(→ 132)	B	B5	C5	E5	F5	G5	L	L1	L5	S5	T1	U	U1	Z5
AM213/215	2.76 in	8.50 in	11	7.25 in	5	228	535	3.38 in	0.25 in	15	1.52 in	1.375 in	0.312 in	157.5
AM254/256	3.65 in	8.50 in	12	7.25 in	5	228	586	4.00 in	0.25 in	15	1.80 in	1.625 in	0.375 in	208
AM284/286	4.00 in	10.50 in	15	9.00 in	5	286	593	4.62 in	0.25 in	15	2.10 in	1.875 in	0.500 in	215
AM324/326	3.88 in	12.50 in	17	11.0 in	5	356	653	5.25 in	0.25 in	17.5	2.36 in	2.125 in	0.500 in	275
AM364/365	4.51 in	12.50 in	17	11.0 in	5	356	653	5.88 in	0.25 in	17.5	2.66 in	2.375 in	0.625 in	275

Note: Dimensions in mm unless otherwise noted. For all available output shaft diameters, see page 411. For dimensions of compound gear units (ex: FAZ127R77) see page 401.

9 F - theSnuggler® Helical

F.. AM.. [NEMA dimensions]

FT127..

42 052 00 11

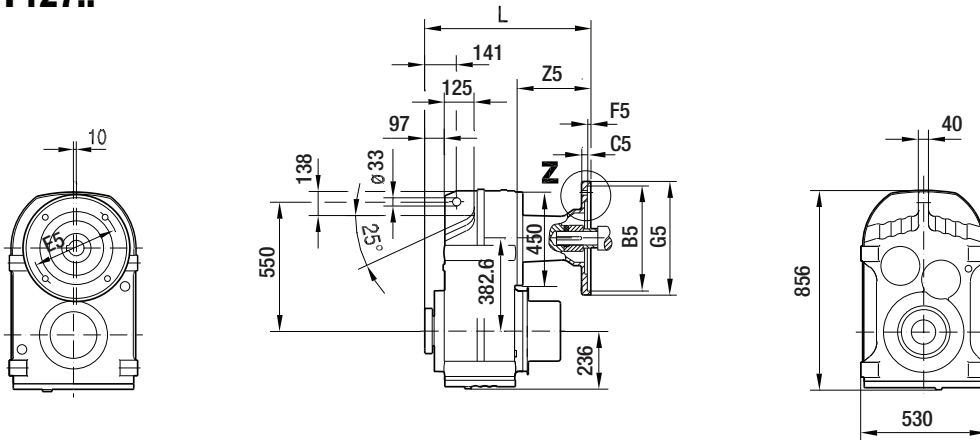

NON-Symmetrical FT127..

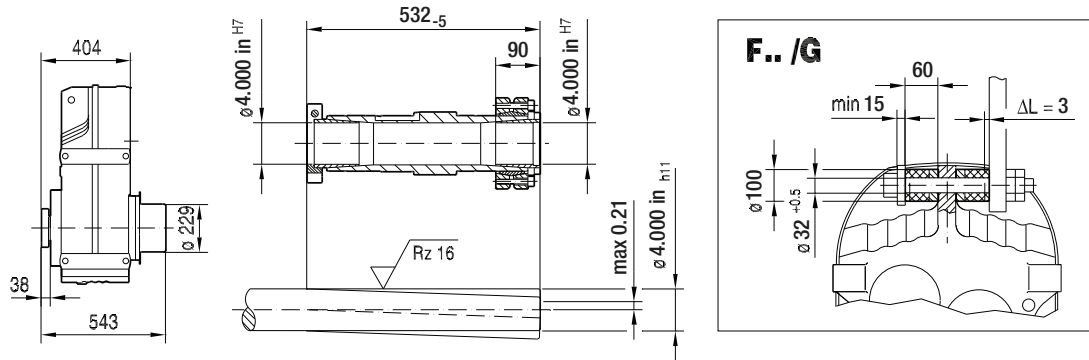

Symmetrical FT127B..

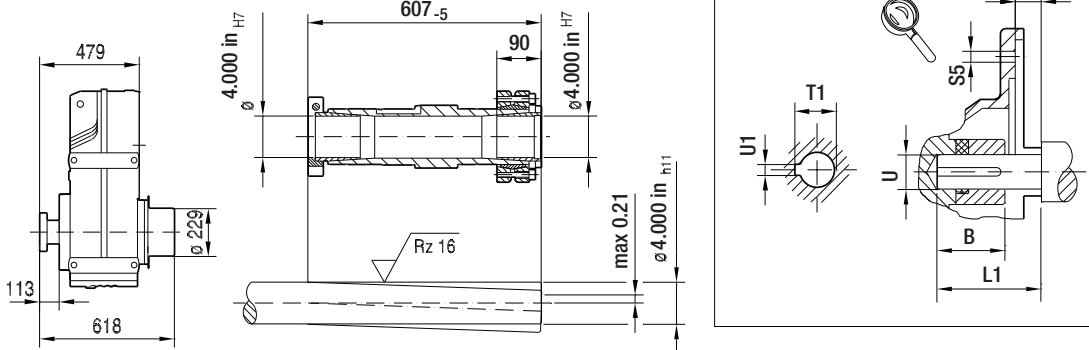

(→ 132)	B	B5	C5	E5	F5	G5	L	L1	L5	S5	T1	U	U1	Z5
AM213/215	2.76 in	8.50 in	11	7.25 in	5	228	562	3.38 in	0.25 in	15	1.52 in	1.375 in	0.312 in	157.5
AM254/256	3.65 in	8.50 in	12	7.25 in	5	228	612	4.00 in	0.25 in	15	1.80 in	1.625 in	0.375 in	208
AM284/286	4.00 in	10.50 in	15	9.00 in	5	286	619	4.62 in	0.25 in	15	2.10 in	1.875 in	0.500 in	215
AM324/326	3.88 in	12.50 in	17	11.0 in	5	356	679	5.25 in	0.25 in	17.5	2.36 in	2.125 in	0.500 in	275
AM364/365	4.51 in	12.50 in	17	11.0 in	5	356	679	5.88 in	0.25 in	17.5	2.66 in	2.375 in	0.625 in	275

Note: Dimensions in mm unless otherwise noted. For all available output shaft diameters, see page 413. For dimensions of compound gear units (ex: FT127R77) see page 401.

F157..

42 053 00 11

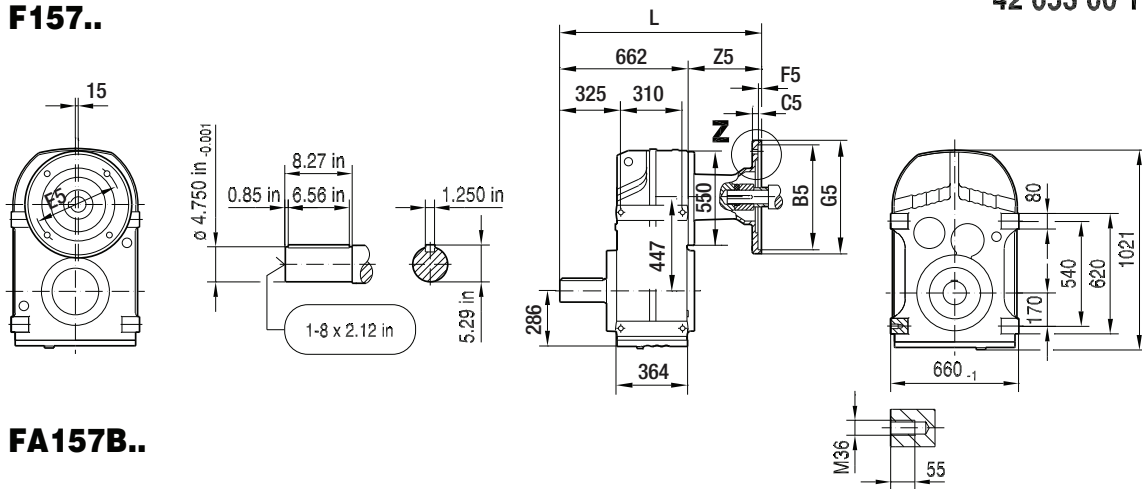

FA157B..

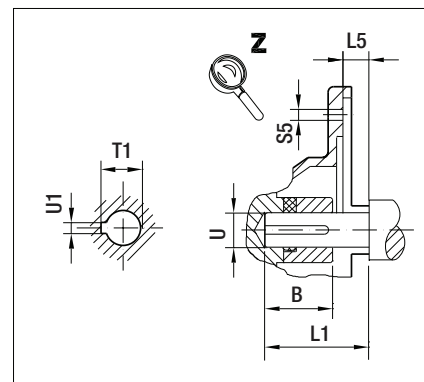
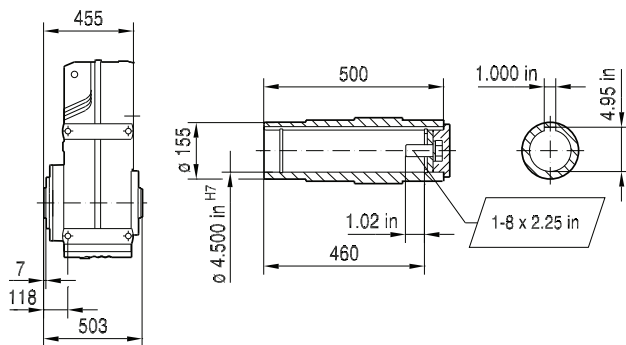

FH157B..

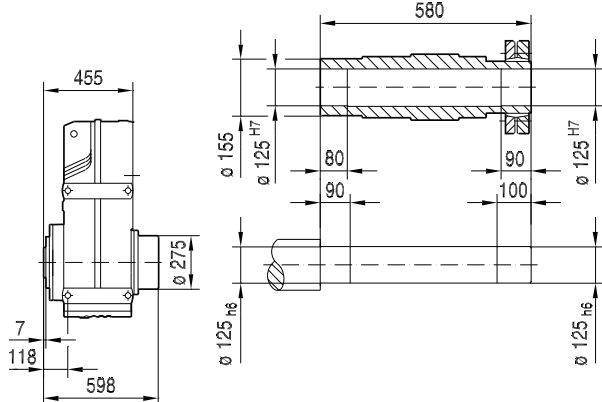

(→ 132)	B	B5	C5	E5	F5	G5	L	L1	L5	S5	T1	U	U1	Z5
AM254/256	3.65 in	8.50 in	12	7.25 in	5	228	862	4.00 in	0.25 in	15	1.80 in	1.625 in	0.375 in	200
AM284/286	4.00 in	10.50 in	15	9.00 in	5	286	869	4.62 in	0.25 in	15	2.10 in	1.875 in	0.500 in	207
AM324/326	3.88 in	12.50 in	17	11.0 in	5	356	929	5.25 in	0.25 in	17.5	2.36 in	2.125 in	0.500 in	267
AM364/365	4.51 in	12.50 in	17	11.0 in	5	356	929	5.88 in	0.25 in	17.5	2.66 in	2.375 in	0.625 in	267

Note: Dimensions in mm unless otherwise noted. For all available output shaft diameters, see page 409. For dimensions of compound gear units (ex: F157R97) see page 401.

9 F - theSnuggler® Helical

F.. AM.. [NEMA dimensions]

FF157..

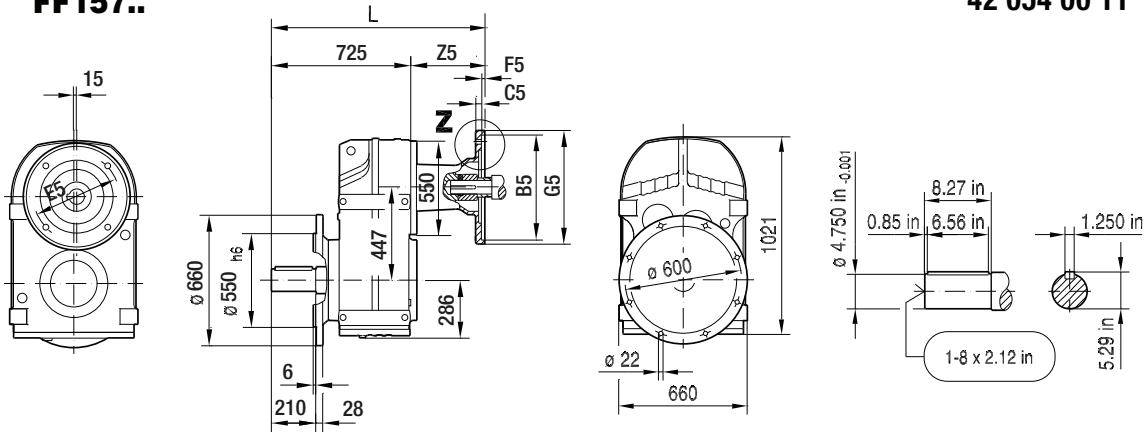

42 054 00 11

FAF157..

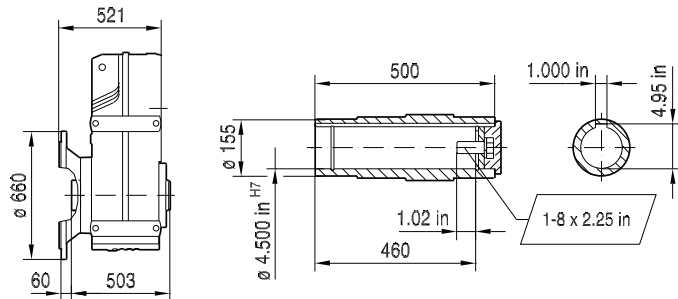

FHF157..

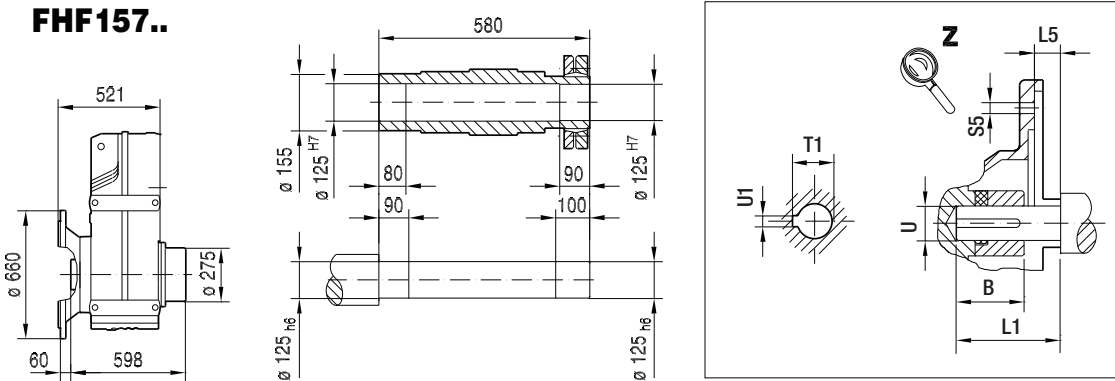

(→ 132)	B	B5	C5	E5	F5	G5	L	L1	L5	S5	T1	U	U1	Z5
AM254/256	3.65 in	8.50 in	12	7.25 in	5	228	925	4.00 in	0.25 in	15	1.80 in	1.625 in	0.375 in	200
AM284/286	4.00 in	10.50 in	15	9.00 in	5	286	932	4.62 in	0.25 in	15	2.10 in	1.875 in	0.500 in	207
AM324/326	3.88 in	12.50 in	17	11.0 in	5	356	992	5.25 in	0.25 in	17.5	2.36 in	2.125 in	0.500 in	267
AM364/365	4.51 in	12.50 in	17	11.0 in	5	356	992	5.88 in	0.25 in	17.5	2.66 in	2.375 in	0.625 in	267

Note: Dimensions in mm unless otherwise noted. For all available output shaft diameters, see page 409. For dimensions of compound gear units (ex: FF157R97) see page 401.

FA157..

42 055 00 11

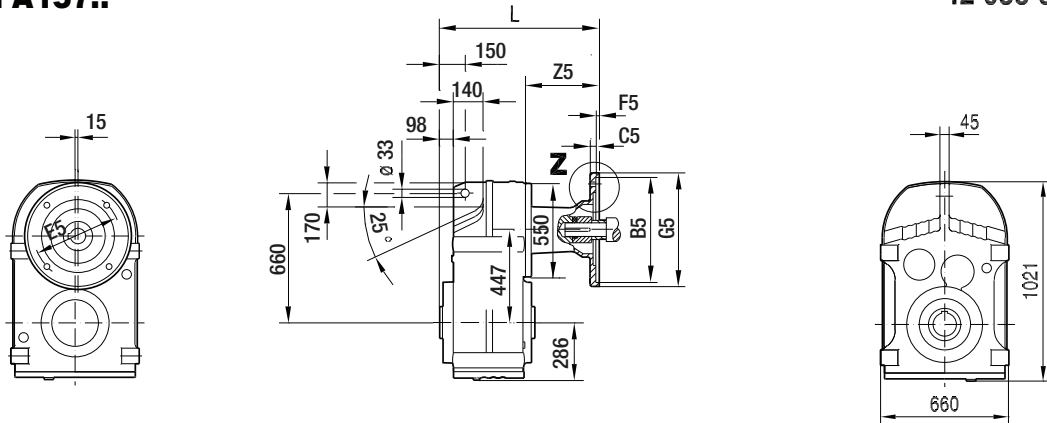

FA157..

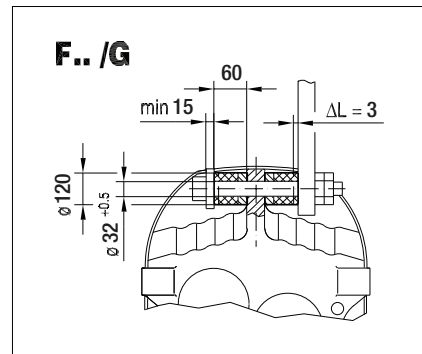
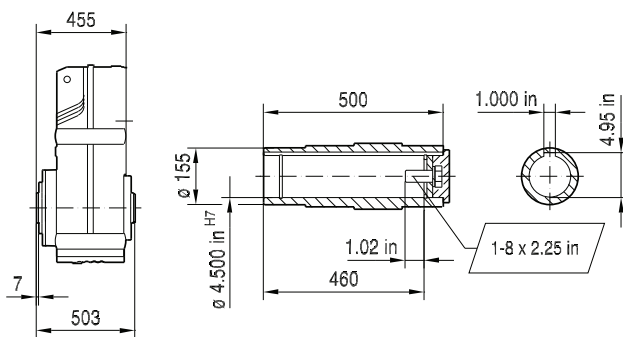

FH157..

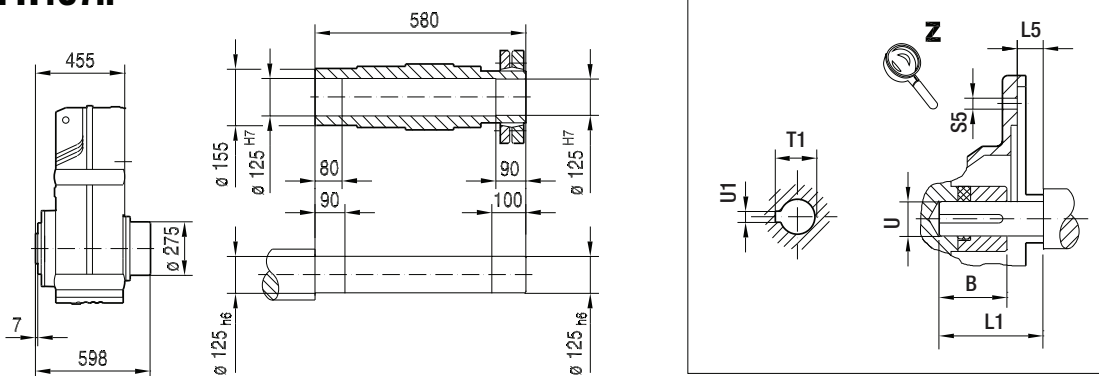

(→ 132)	B	B5	C5	E5	F5	G5	L	L1	L5	S5	T1	U	U1	Z5
AM254/256	3.65 in	8.50 in	12	7.25 in	5	228	655	4.00 in	0.25 in	15	1.80 in	1.625 in	0.375 in	200
AM284/286	4.00 in	10.50 in	15	9.00 in	5	286	662	4.62 in	0.25 in	15	2.10 in	1.875 in	0.500 in	207
AM324/326	3.88 in	12.50 in	17	11.0 in	5	356	722	5.25 in	0.25 in	17.5	2.36 in	2.125 in	0.500 in	267
AM364/365	4.51 in	12.50 in	17	11.0 in	5	356	722	5.88 in	0.25 in	17.5	2.66 in	2.375 in	0.625 in	267

Note: Dimensions in mm unless otherwise noted. For all available output shaft diameters, see page 411. For dimensions of compound gear units (ex: FA157R97) see page 401.

9 F - theSnuggler® Helical

F.. AM.. [NEMA dimensions]

FAZ157..

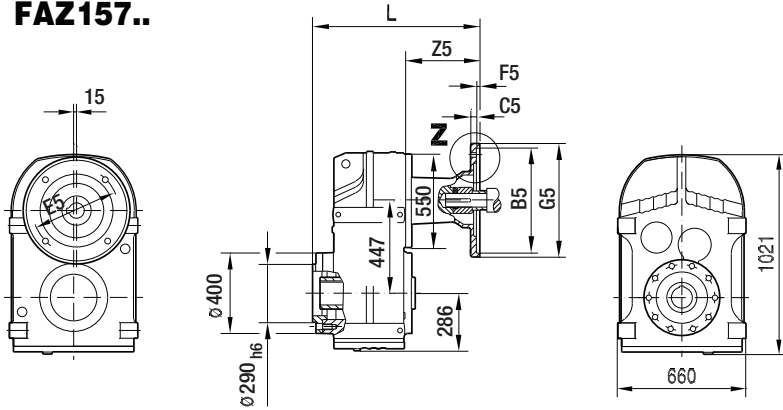

42 056 00 11

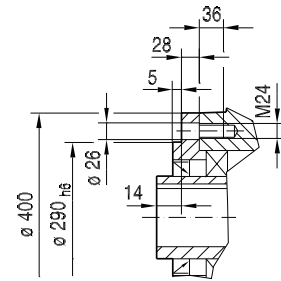

FAZ157..

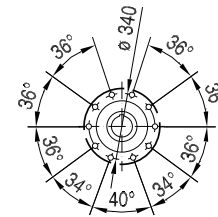
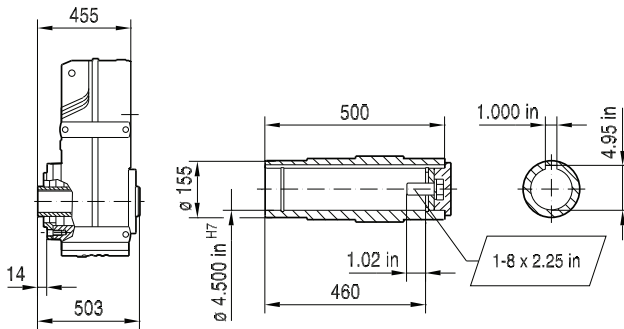

FHZ157..

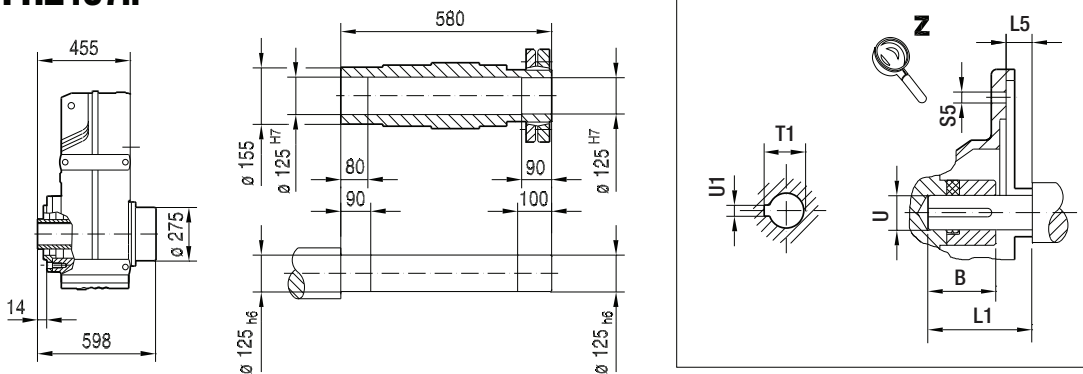

(→ 132)	B	B5	C5	E5	F5	G5	L	L1	L5	S5	T1	U	U1	Z5
AM254/256	3.65 in	8.50 in	12	7.25 in	5	228	655	4.00 in	0.25 in	15	1.80 in	1.625 in	0.375 in	200
AM284/286	4.00 in	10.50 in	15	9.00 in	5	286	662	4.62 in	0.25 in	15	2.10 in	1.875 in	0.500 in	207
AM324/326	3.88 in	12.50 in	17	11.0 in	5	356	722	5.25 in	0.25 in	17.5	2.36 in	2.125 in	0.500 in	267
AM364/365	4.51 in	12.50 in	17	11.0 in	5	356	722	5.88 in	0.25 in	17.5	2.66 in	2.375 in	0.625 in	267

Note: Dimensions in mm unless otherwise noted. For all available output shaft diameters, see page 411. For dimensions of compound gear units (ex: FAZ157R97) see page 401.

FT157..

42 057 00 11

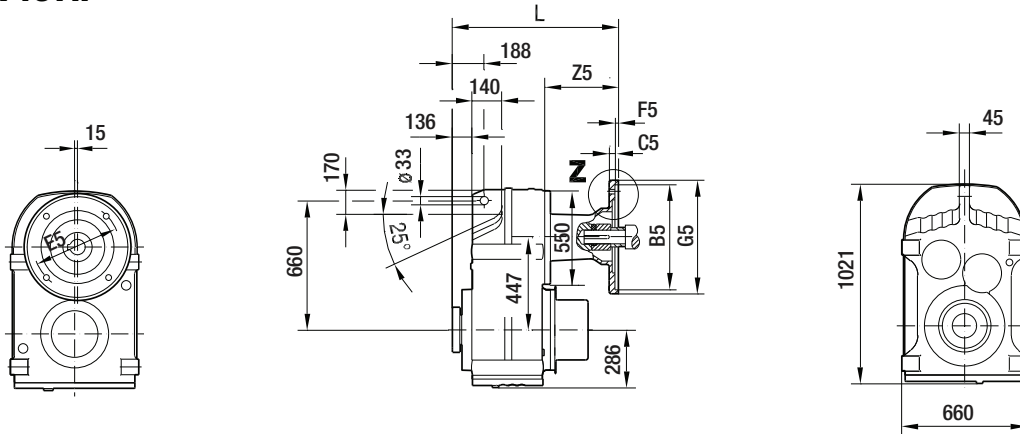

**NON-Symmetrical
FT157..**

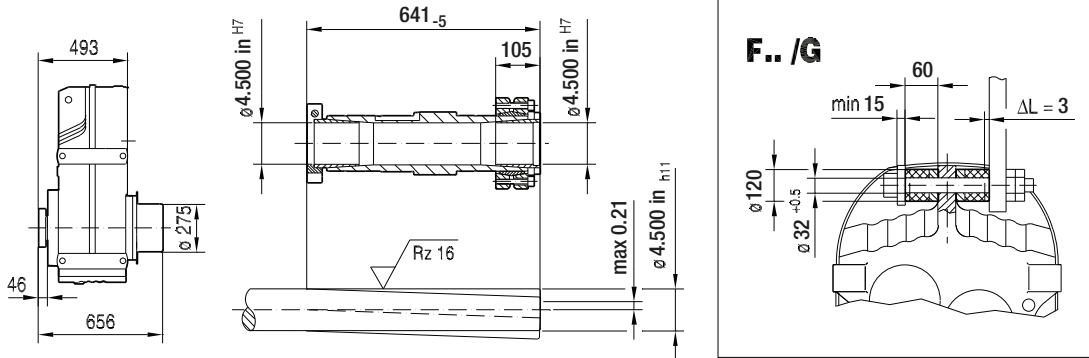

**Symmetrical
FT157B..**

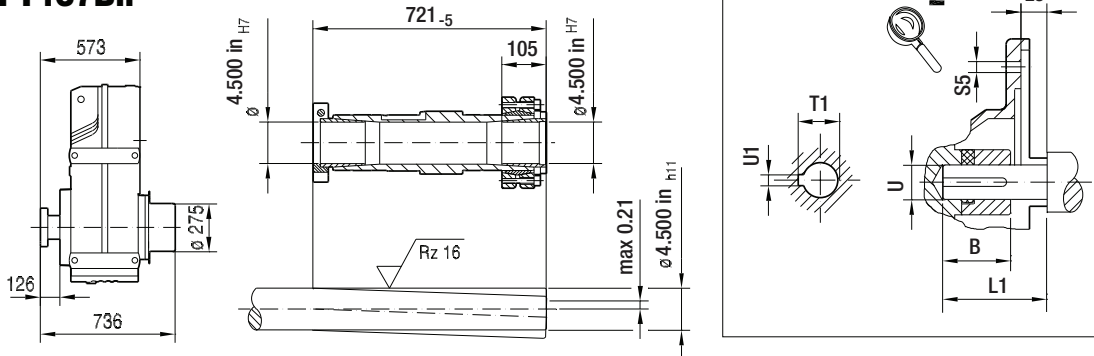

(→ 132)	B	B5	C5	E5	F5	G5	L	L1	L5	S5	T1	U	U1	Z5
AM254/256	3.65 in	8.50 in	12	7.25 in	5	228	693	4.00 in	0.25 in	15	1.80 in	1.625 in	0.375 in	200
AM284/286	4.00 in	10.50 in	15	9.00 in	5	286	700	4.62 in	0.25 in	15	2.10 in	1.875 in	0.500 in	207
AM324/326	3.88 in	12.50 in	17	11.0 in	5	356	760	5.25 in	0.25 in	17.5	2.36 in	2.125 in	0.500 in	267
AM364/365	4.51 in	12.50 in	17	11.0 in	5	356	760	5.88 in	0.25 in	17.5	2.66 in	2.375 in	0.625 in	267

Note: Dimensions in mm unless otherwise noted. For all available output shaft diameters, see page 413. For dimensions of compound gear units (ex: FT157R97) see page 401.

9 F - theSnuggler® Helical

F..AM.. [IEC dimensions]

9.4 F..AM.. [IEC dimensions]

23 002 100

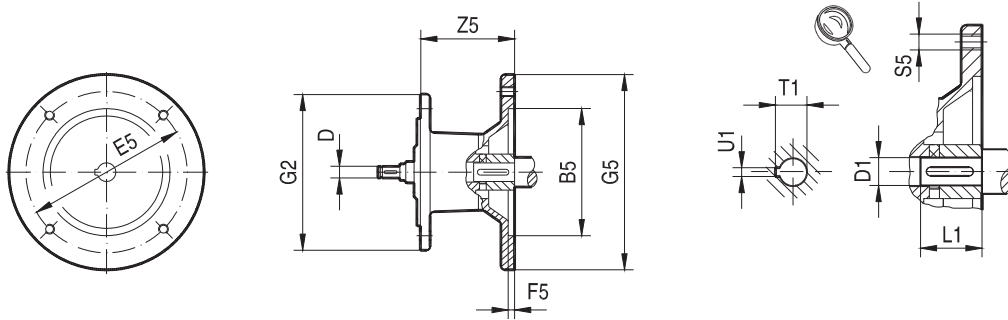

		Dimensions in mm											
		B5	D	E5	F5	G2	G5	S5	Z5	D1	L1	T1	U1
F..27 F..37 F..47	AM63	95	10	115	3.5	120	140	M8	72	11	23	12.8	4
	AM71 ¹⁾	110		130	4		160			14	30	16.3	5
	AM80 ¹⁾	130	12	165	4.5		200	M10	106	19	40	21.8	6
	AM90 ¹⁾		14							24	50	27.3	8
F..57 F..67	AM63	95	10	115	3.5	160	140	M8	66	11	23	12.8	4
	AM71	110		130	4		160			14	30	16.3	5
	AM80	130	12	165	4.5		200	M10	99	19	40	21.8	6
	AM90		14							24	50	27.3	8
	AM100 ¹⁾	180	16	215	5		250	M12	134	28	60	31.3	8
	AM112 ¹⁾		18							300	191	38	80
	AM132S/M ¹⁾	230	22	265									
		230	28	265									
F..77	AM63	95	10	115	3.5	200	140	M8	60	11	23	12.8	4
	AM71	110		130	4		160			14	30	16.3	5
	AM80	130	12	165	4.5		200	M10	92	19	40	21.8	6
	AM90		14							24	50	27.3	8
	AM100 ¹⁾	180	16	215	5		250	M12	126	28	60	31.3	8
	AM112 ¹⁾		18							300	179	38	80
	AM132S/M ¹⁾	230	22	265									
AM132ML ¹⁾		28	265										
F..87	AM80	130	12	165	4.5	250	200	M10	87	19	40	21.8	6
	AM90		14							24	50	27.3	8
	AM100	180	16	215	5		250	M12	121	28	60	31.3	8
	AM112		18							300	174	38	80
	AM132S/M	230	22	265	5		300	M12	174	38	80	41.3	10
	AM132ML		28							350	232	42	110
	AM160 ¹⁾	250	28	300	6		350	M16	232	48	110	51.8	14
AM180 ¹⁾	32												

1) Check dimension 1/2 G5 because component may protrude past foot-mounting surface if installed on R, K, S or W foot-mounted gear unit.

23 003 100

Fig.1

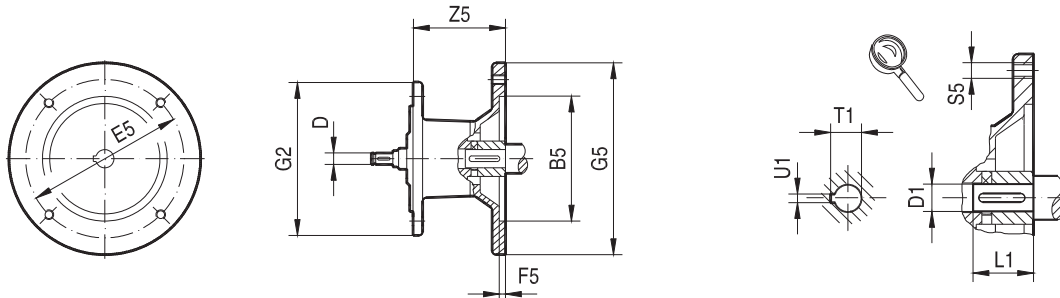

Fig.2

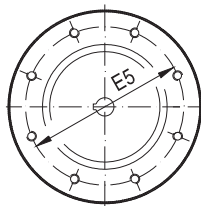

		Fig.	Dimensions in mm												
			B5	D	E5	F5	G2	G5	S5	Z5	D1	L1	T1	U1	
F..97	AM100	1	180	16	215	5	300	250	M12	116	28	60	31.3	8	
	AM112			18											
	AM132S/M		230	22	265										
	AM132ML			28											
	AM160		250	28	300			6	350	M16	227	42	110	45.3	12
	AM180			32								48		51.8	14
	AM200		300	38	350			7	400	268	55	59.3	16		
F..107	AM100	1	180	16	215	5	350	250	M12	110	28	60	31.3	8	
	AM112			18											
	AM132S/M		230	22	265										
	AM132ML			28											
	AM160		250	28	300			6	350	M16	221	42	110	45.3	12
	AM180			32								48		51.8	14
	AM200		300	38	350			7	400	262	55	59.3	16		
	AM225	350		38		400	450							277	60

23 004 100

Fig.1

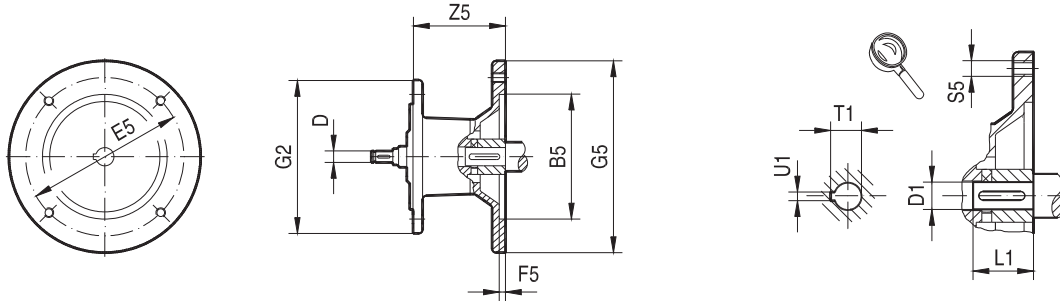

Fig.2

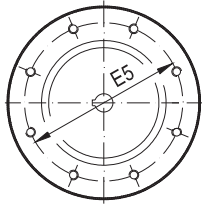
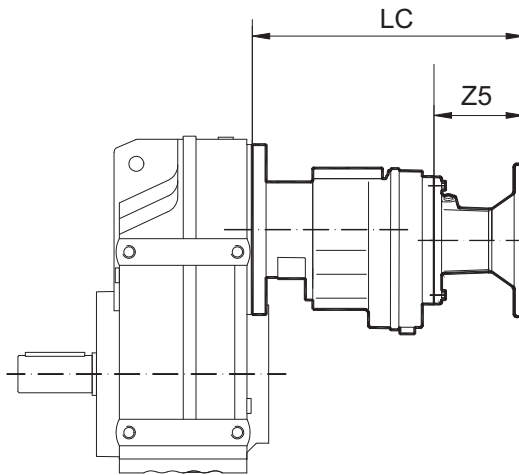

		Fig.	Dimensions in mm												
			B5	D	E5	F5	G2	G5	S5	Z5	D1	L1	T1	U1	
F..127	AM132S/M	1	230	22	265	5	450	300	M12	148	38	80	41.3	10	
	AM132ML			28							38				
	AM160	2	250	28	300	6		350	350	M16	206	42	110	45.3	12
	AM180			32								48			
	AM200	2	300	38	350	7		400	400	M16	247	55	140	59.3	16
	AM225			38								60			
	AM250	2	450	48	500	7		550	550	M16	336	65	140	69.4	18
	AM280			75								75			
F..157	AM160	1	250	28	300	6	550	350	M16	198	42	110	45.3	12	
	AM180			32							48				
	AM200	2	300	38	350	7		400	400	M16	239	55	140	59.3	16
	AM225			38								60			
	AM250	2	450	48	500	7		550	550	M16	328	65	140	69.4	18
	AM280			75								75			

9.5 F.. R.. AM.. [compound dimensions]



F_R_AM

Large Unit	Small Unit	Adapter	Z5	LC
F..47 F..57 F..67	R37	AM56	93.5	258.5
		AM143	117	282
		AM145	117	282
F..77	R37	AM56	93.5	250.5
		AM143	117	274
		AM145	117	274
F..87	R57	AM56	87	303
		AM143	110.5	326.5
		AM145	110.5	326.5
		AM182	147.5	363.5
		AM184	147.5	363.5
		AM213/215	200.5	416.5
F..97	R57	AM56	87	298
		AM143	110.5	321.5
		AM145	110.5	321.5
		AM182	147.5	358.5
		AM184	147.5	358.5
F..107	R77	AM56	81	328
		AM143	103.5	350.5
		AM145	103.5	350.5
		AM182	139.5	386.5
		AM184	139.5	386.5
		AM213/215	188.5	435.5

Large Unit	Small Unit	Adapter	Z5	LC	
F..127	R77	AM56	81	313	
		AM143	103.5	335.5	
		AM145	103.5	335.5	
		AM182	139.5	371.5	
		AM184	139.5	371.5	
			AM213/215	188.5	420.5
	R87	AM143	98.5	378.5	
		AM145	98.5	378.5	
		AM182	134.5	414.5	
		AM184	134.5	414.5	
AM213/215		183.5	463.5		
		AM254/256	234	514	
		AM284/286	241	521	
F..157	R97	AM182	129.5	454.5	
		AM184	129.5	454.5	
		AM213/215	178.5	503.5	
		AM254/256	229	554	
		AM284/286	236	561	
		AM324/326	296	621	
		AM364/365	296	621	

9.6 F.. AD.. [dimensions]

9.6.1 Input shaft - Inch

F.. AD..

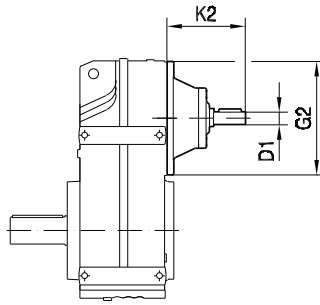
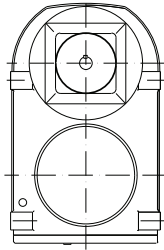

42 098 01 01US

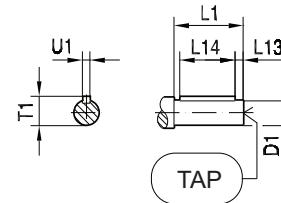

F.. AD../ZR

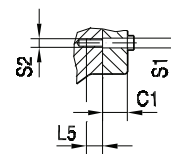
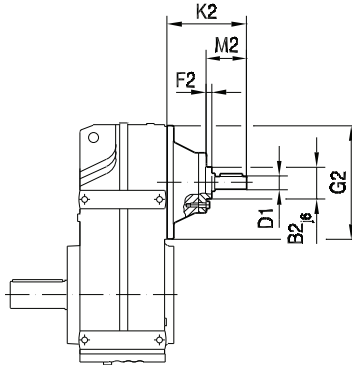
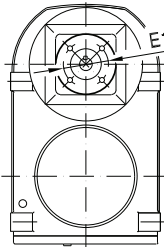

		B2	C1	D1	E1	F2	G2	K2	L1	L5	L13	L14	M2	S1	S2	T1	U1	TAP (inch)
F..27	AD1	-	-	0.625 in	-	-	120	102	40	-	4	32	-	-	-	0.70 in	0.1875 in	1/4-20 x0.63
F..37	AD2	55	13.5	0.750 in	80	8		130	40	12	4	32	50	9	M8	0.83 in		
F..47	AD3	70	15.5	0.875 in	105	8		159	50	16	5	40	60	11	M10	0.96 in		
F..57	AD2	55	13.5	0.750 in	80	8	160	116	40	12	4	32	50	9	M8	0.83 in	0.1875 in	1/4-20 x0.63
	AD3	70	15.5	0.875 in	105	8		151	50	16	5	40	60	11	M10	0.96 in		
	AD4	100	16	1.375 in	130	13		224	80	20	5	70	95.5	13.5	M12	1.51 in		
F..77	AD2	55	13.5	0.750 in	80	8	200	111	40	12	4	32	50	9	M8	0.83 in	0.1875 in	1/4-20 x0.63
	AD3	70	15.5	0.875 in	105	8		156	60	16	5	50	70	11	M10	0.96 in		
	AD4	100	16	1.375 in	130	13		219	80	20	5	70	95.5	13.5	M12	1.51 in		
F..87	AD5	120	24	1.625 in	180	11	250	292	110	20	10	70	126	13.5	M12	1.79 in	0.375 in	5/8-11 x1.38
	AD3	70	15.5	0.875 in	105	8		151	60	16	5	50	70	11	M10	0.96 in	0.1875 in	5/16-18 x0.87
	AD4	100	16	1.375 in	130	13		214	80	20	5	70	95.5	13.5	M12	1.51 in	0.3125 in	1/2-13 x1.12
F..97	AD5	120	24	1.625 in	180	11	300	287	110	20	10	70	126	13.5	M12	1.79 in	0.375 in	5/8-11 x1.38
	AD6	130	22.5	1.875 in	200	11		327	110	26	10	80	130.5	17.5	M16	2.09 in	0.50 in	5/8-11 x1.38
	AD3	70	15.5	0.875 in	105	8		145	60	16	5	50	70	11	M10	0.96 in	0.1875 in	5/16-18 x0.87
F..107	AD4	100	16	1.375 in	130	13	350	208	80	20	5	70	95.5	13.5	M12	1.51 in	0.3125 in	1/2-13 x1.12
	AD5	120	24	1.625 in	180	11		281	110	20	10	70	126	13.5	M12	1.79 in	0.375 in	5/8-11 x1.38
	AD6	130	22.5	1.875 in	200	11		321	110	26	10	80	130.5	17.5	M16	2.09 in	0.50 in	5/8-11 x1.38
F..127	AD4	100	16	1.375 in	130	13	450	193	80	20	5	70	95.5	13.5	M12	1.51 in	0.3125 in	1/2-13 x1.12
	AD5	120	24	1.625 in	180	11		266	110	20	10	70	126	13.5	M12	1.79 in	0.375 in	5/8-11 x1.38
	AD6	130	22.5	1.875 in	200	11		306	110	26	10	80	130.5	17.5	M16	2.09 in	0.50 in	5/8-11 x1.38
F..157	AD7	125	19	2.125 in	190	13	550	300	110	30	10	90	133	22	M20	2.35 in	0.50 in	3/4-10 x1.61
	AD8	120	22.5	2.750 in	210	5		383	140	19.5	15	110	155	13.5	M12	3.03 in	0.625 in	3/4-10 x1.61
	AD5	120	24	1.625 in	180	11		258	110	20	10	70	126	13.5	M12	1.79 in	0.375 in	5/8-11 x1.38
F..157	AD6	130	22.5	1.875 in	200	11	550	298	110	26	10	80	130.5	17.5	M16	2.09 in	0.50 in	5/8-11 x1.38
	AD7	125	19	2.125 in	190	13		292	110	30	10	90	133	22	M20	2.35 in	0.50 in	3/4-10 x1.61
	AD8	120	22.5	2.750 in	210	5		374	140	19.5	15	110	155	13.5	M12	3.03 in	0.625 in	3/4-10 x1.61

9.6.2 Input Shaft - Metric

F.. AD..

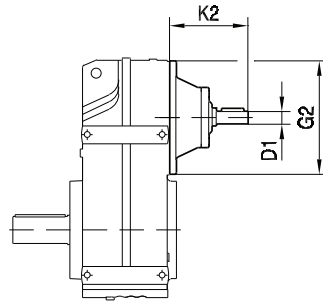
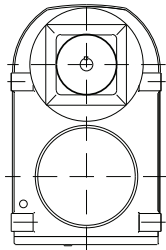

42 098 01 01

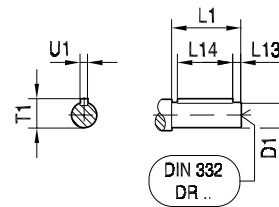

F.. AD../ZR

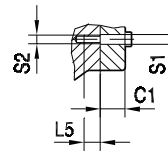
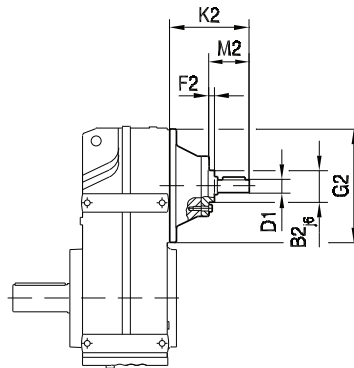
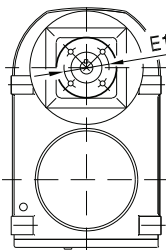

		B2	C1	E1	F2	G2	K2	L5	M2	S1	S2	D1	L1	L13	L14	T1	U1
F..27 F..37 F..47	AD1	-	-	-	-	120	102	-	-	-	-	16	40	4	32	18	5
	AD2, AD2/ZR	55	13.5	80	8		130	12	50	9	M8	19	40	4	32	21.5	6
F..57 F..67	AD2, AD2/ZR	55	13.5	80	8	160	123	12	50	9	M8	19	40	4	32	21.5	6
	AD3, AD3/ZR	70	15.5	105	8		159	16	60	11	M10	24	50	5	40	27	8
F..77	AD2, AD2/ZR	55	13.5	80	8	200	116	12	50	9	M8	19	40	4	32	21.5	6
	AD3, AD3/ZR	70	15.5	105	8		151	16	60	11	M10	24	50	5	40	27	8
	AD4, AD4/ZR	100	16	130	13		224	20	95.5	13.5	M12	38	80	5	70	41	10
F..87	AD2, AD2/ZR	55	13.5	80	8	250	111	12	50	9	M8	19	40	4	32	21.5	6
	AD3, AD3/ZR	70	15.5	105	8		156	16	70	11	M10	28	60	5	50	31	8
	AD4, AD4/ZR	100	16	130	13		219	20	95.5	13.5	M12	38	80	5	70	41	10
	AD5, AD5/ZR	120	24	180	11		292	20	126	13.5	M12	42	110	10	70	45	12
F..97	AD3, AD3/ZR	70	15.5	105	8	300	151	16	70	11	M10	28	60	5	50	31	8
	AD4, AD4/ZR	100	16	130	13		214	20	95.5	13.5	M12	38	80	5	70	41	10
	AD5, AD5/ZR	120	24	180	11		287	20	126	13.5	M12	42	110	10	70	45	12
	AD6, AD6/ZR	130	22.5	200	11		327	26	130.5	17.5	M16	48	110	10	80	51.5	14
F..107	AD3, AD3/ZR	70	15.5	105	8	350	145	16	70	11	M10	28	60	5	50	31	8
	AD4, AD4/ZR	100	16	130	13		208	20	95.5	13.5	M12	38	80	5	70	41	10
	AD5, AD5/ZR	120	24	180	11		281	20	126	13.5	M12	42	110	10	70	45	12
	AD6, AD6/ZR	130	22.5	200	11		321	26	130.5	17.5	M16	48	110	10	80	51.5	14
F..127	AD4, AD4/ZR	100	16	130	13	450	193	20	95.5	13.5	M12	38	80	5	70	41	10
	AD5, AD5/ZR	120	24	180	11		266	20	126	13.5	M12	42	110	10	70	45	12
	AD6, AD6/ZR	130	22.5	200	11		306	26	130.5	17.5	M16	48	110	10	80	51.5	14
	AD7, AD7/ZR	125	19	190	13		300	30	133	22	M20	55	110	10	90	59	16
	AD8, AD8/ZR	120	22.5	210	5		383	19.5	155	13.5	M12	70	140	15	110	74.5	20
F..157	AD5, AD5/ZR	120	24	180	11	550	258	20	126	13.5	M12	42	110	10	70	45	12
	AD6, AD6/ZR	130	22.5	200	11		298	26	130.5	17.5	M16	48	110	10	80	51.5	14
	AD7, AD7/ZR	125	19	190	13		292	30	133	22	M20	55	110	10	90	59	16
	AD8, AD8/ZR	120	22.5	210	5		374	19.5	155	13.5	M12	70	140	15	110	74.5	20

9.7 F.. R.. AD.. [compound dimensions]

F_R_AD

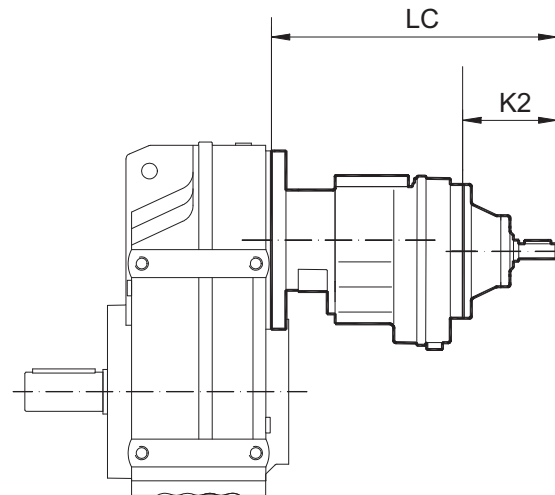

Large Unit	Small Unit	Adapter	K2	LC
F..47 F..57 F..67	R37	AD1	102	267
		AD2	130	295
	F..77	R37	AD1	102
		AD2	130	287
F..87	R57	AD2	123	339
		AD3	159	375
F..97	R57	AD2	123	334
		AD3	159	370
F..107	R77	AD2	116	363
		AD3	151	398
		AD4	224	471
F..127	R77	AD2	116	348
		AD3	151	383
		AD4	224	456
	R87	AD2	111	391
		AD3	156	436
		AD4	219	499
		AD5	292	572
F..157	R97	AD3	151	476
		AD4	214	539
		AD5	287	612
		AD6	327	652

9.8 F.. AD../P [dimensions]

42 099 01 01

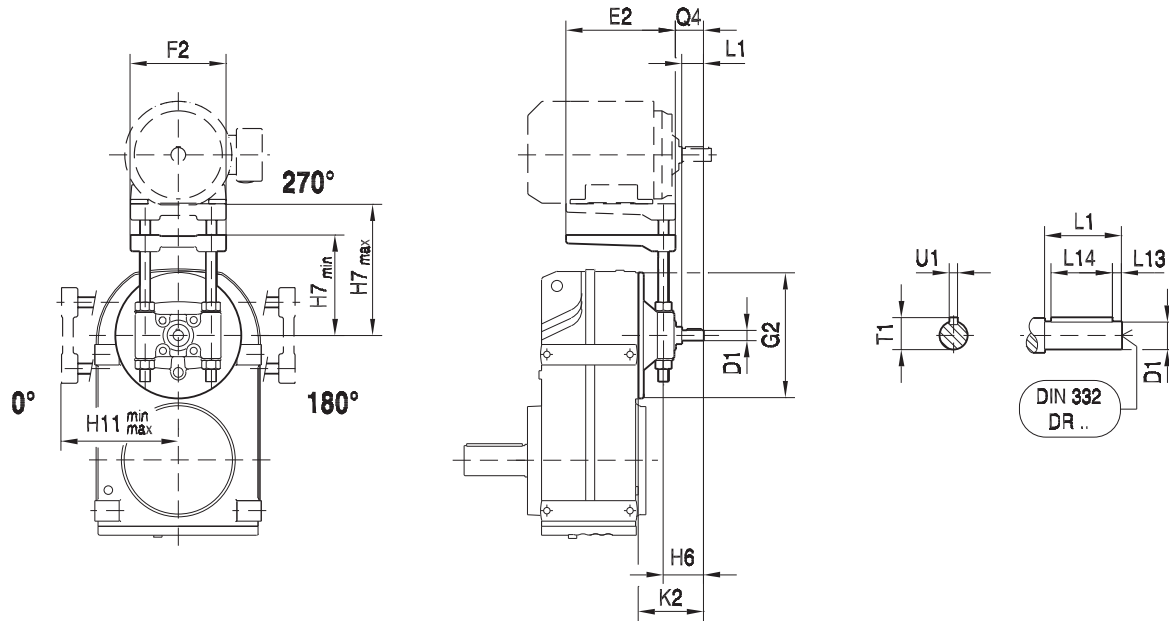

9

		E2	F2	G2	H6	H7 min	H7 max	H11 min	H11 max	K2	Q4	D1	L1	L13	L14	T1	U1
F..27	AD2/P	195	180	120	65	100	165	125	165	130	43	19	40	4	32	21.5	6
F..37	AD2/P	195	180	120	65	100	165	125	165	130	43	19	40	4	32	21.5	6
F..47	AD2/P	195	180	120	65	105	165	125	165	130	43	19	40	4	32	21.5	6
F..57	AD2/P	195	180	160	65	125	165	140	200	123	43	19	40	4	32	21.5	6
	AD3/P	230	240		80	130	175	150	230	159	54	24	50	5	40	27	8
F..67	AD2/P	195	180	160	65	125	165	145	200	123	43	19	40	4	32	21.5	6
	AD3/P	230	240		80	130	175	155	230	159	54	24	50	5	40	27	8
F..77	AD2/P	195	180	200	65	145	200	170	200	116	43	19	40	4	32	21.5	6
	AD3/P	230	240		80	150	230	175	230	151	54	24	50	5	40	27	8
	AD4/P	345	291		118	155	210	185	210	224	83	38	80	5	70	41	10
F..87	AD2/P	195	180	250	65	170	260	205	260	111	43	19	40	4	32	21.5	6
	AD3/P	230	240		90	175	230	210	320	156	64	28	60	5	50	31	8
	AD4/P	345	291		118	180	280	215	280	219	83	38	80	5	70	41	10
	AD5/P	430	355		153	185	250	225	325	292	113	42	110	10	70	45	12
F..97	AD3/P	230	240	300	90	205	320	240	320	151	64	28	60	5	50	31	8
	AD4/P	345	291		118	210	280	245	280	214	83	38	80	5	70	41	10
	AD5/P	430	355		153	215	325	250	325	287	113	42	110	10	70	45	12
F..107	AD3/P	230	240	350	90	230	320	270	320	145	64	28	60	5	50	31	8
	AD4/P	345	291		118	240	280	275	360	208	83	38	80	5	70	41	10
	AD5/P	430	355		153	240	325	280	325	281	113	42	110	10	70	45	12
	AD6/P	495	457		163	245	310	285	310	321	114	48	110	10	80	51.5	14

9 F - theSnuggler® Helical

F.. AD../P [dimensions]

42 101 01 01

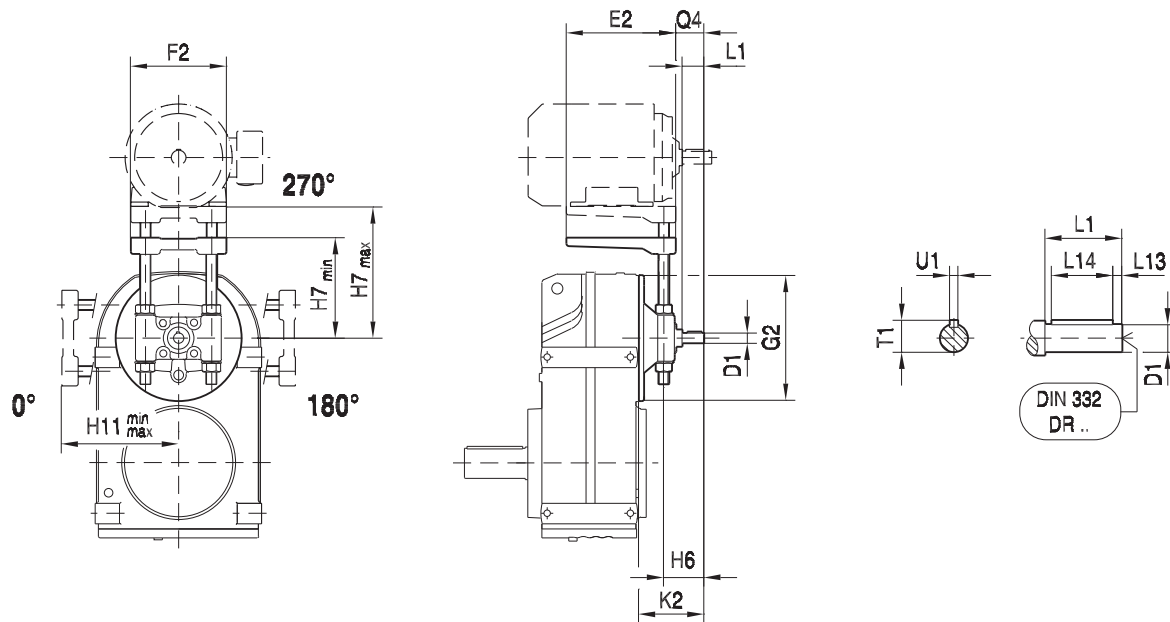

		E2	F2	G2	H6	H7 min	H7 max	H11 min	H11 max	K2	Q4	D1	L1	L13	L14	T1	U1
F..127	AD4/P	345	291	450	118	240	280	310	360	193	83	38	80	5	70	41	10
	AD5/P	430	355		153	295	405	320	405	266	113	42	110	10	70	45	12
	AD6/P	495	457		163	295	360	310	360	306	114	48	110	10	80	51.5	14
	AD7/P	650	570		170	300	365	310	365	300	112	55	110	10	90	59	16
F..157	AD5/P	430	355	550	153	345	405	370	405	258	113	42	110	10	70	45	12
	AD6/P	495	457		163	375	475	380	475	298	114	48	110	10	80	51.5	14
	AD7/P	650	570		170	375	475	385	475	292	112	55	110	10	90	59	16

9.9 F.. AR.. [dimensions]

F.. AR..

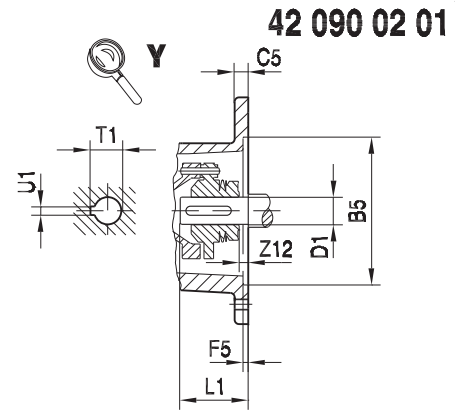
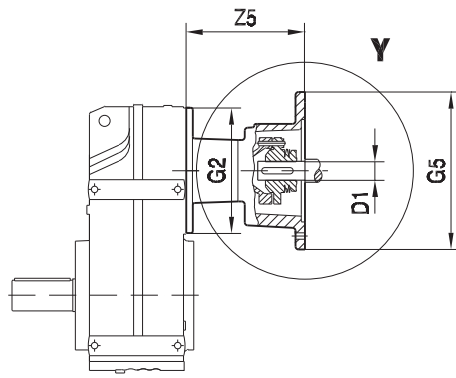
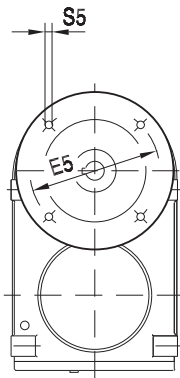

F.. AR../W

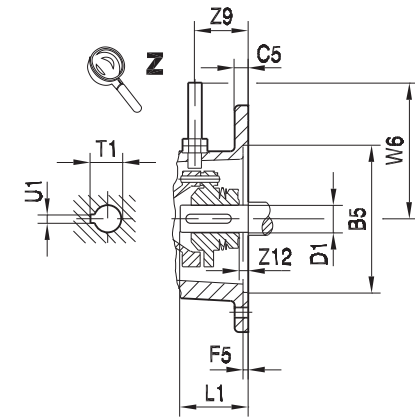
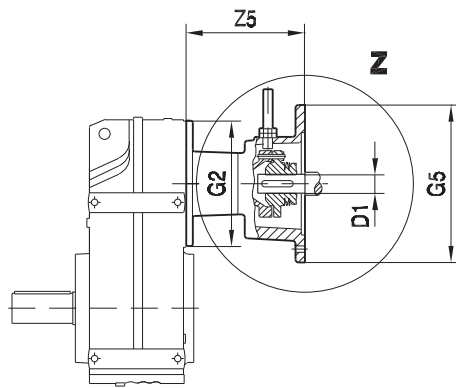
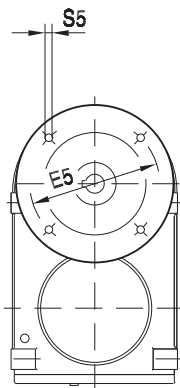

		B5	C5	E5	F5	G2	G5	S5	W6	Z5	Z9	Z12	D1	L1	T1	U1			
F..27 F..37 F..47	AR71	110	10	130	3.5	120	160	M8	120	104	37	0	14	30	16.3	5			
	AR80	130	12	165	4.5		200	M10		140.5			19	40	21.8	6			
	AR90						24	50		27.3			8						
F..57 F..67	AR71	110	10	130	3.5	160	160	M8	120	97.5	37	0	14	30	16.3	5			
	AR80	130	12	165	4.5		200	M10		134			19	40	21.8	6			
	AR90						24	50		27.3			8						
	AR100 AR112	180	15	215	5		250	M12		130			174.5	52	5.5	28	60	31.3	8
F..77	AR71	110	10	130	3.5	200	160	M8	120	91.5	37	0	14	30	16.3	5			
	AR80	130	12	165	4.5		200	M10		127			19	40	21.8	6			
	AR90						24	50		27.3			8						
	AR100 AR112	180	15	215	5		250	M12		130			166.5	52	5.5	28	60	31.3	8
	AR132S/M AR132ML	230	16	265	5		300	M12		145			234	72	5	38	80	41.3	10
F..87	AR80	130	12	165	4.5	250	200	M10	120	122	37	0	19	40	21.8	6			
	AR90												24	50	27.3	8			
	AR100 AR112	180	15	215	5		250	M12		130	161.5	52	5.5	28	60	31.3	8		
	AR132S/M AR132ML	230	16	265	5		300	M12		145	229	72	5	38	80	41.3	10		
	AR160 AR180	250	18	300	6		350	M16		165	306.5	105	35	42	110	45.3	12		

9 F - theSnuggler® Helical

F.. AR.. [dimensions]

F.. AR..

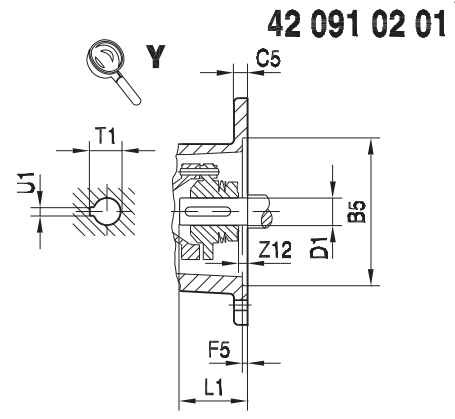
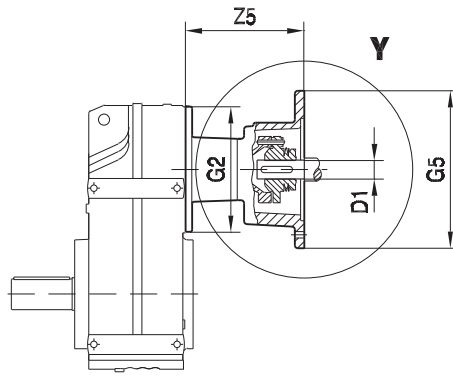
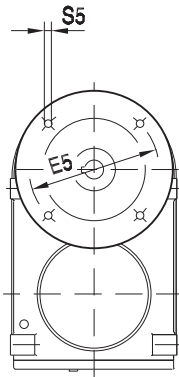

F.. AR../W

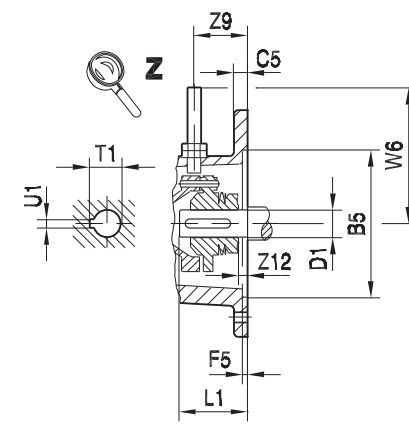
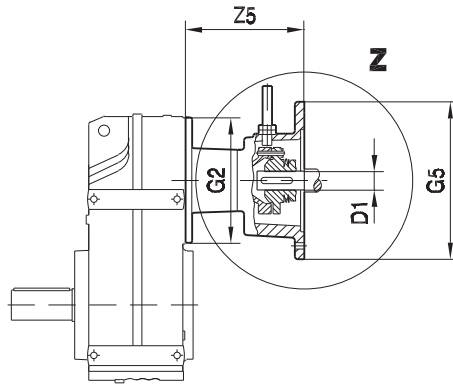
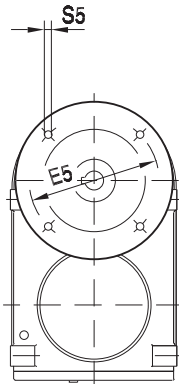

		B5	C5	E5	F5	G2	G5	S5	W6	Z5	Z9	Z12	D1	L1	T1	U1	
F..97	AR100	180	15	215	5	300	250	M12	130	156.5	52	5.5	28	60	31.3	8	
	AR112																
	AR132S/M	230	16	265	5		300	M12	145	224	72	5	38	80	41.3	10	
	AR132ML																
	AR160																
AR180	250	18	300	6	350	M16	165	301.5	105	35	42	110	45.3	12			
													48	110	51.8	14	
F..107	AR100	180	15	215	5	350	250	M12	130	150.5	52	5.5	28	60	31.3	8	
	AR112																
	AR132S/M	230	16	265	5		300	M12	145	218	72	5	38	80	41.3	10	
	AR132ML																
	AR160																
AR180	250	18	300	6	350	M16	165	295.5	105	35	42	110	45.3	12			
													48	110	51.8	14	
F..147	AR132S/M	230	16	265	5	450	300	M12	145	203	72	5	38	80	41.3	10	
	AR132ML																
	AR160	250	18	300	6		350	M16	165	280.5	105	35	42	110	45.3	12	
	AR180																
													48	110	51.8	14	
F..167	AR160	250	18	300	6	550	350	M16	165	272.5	105	35	42	110	45.3	12	
	AR180																
														48	110	51.8	14

9.10 Output shaft sizes

9.10.1 Solid Shafts - Inch

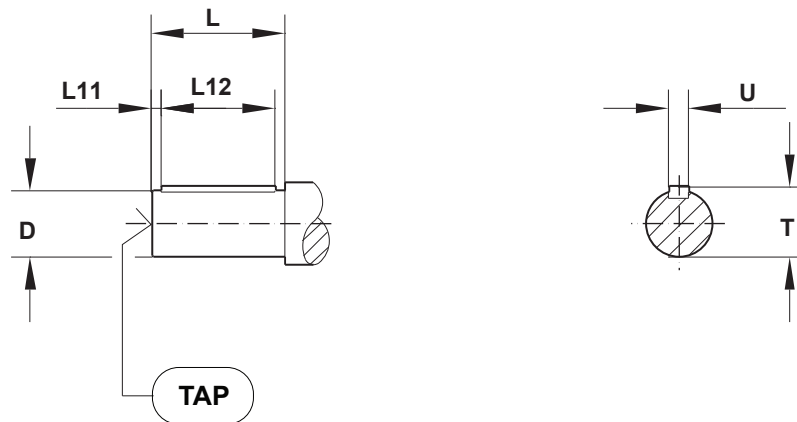

All dimensions in inches								
Model	D	T	U	L ¹⁾	L11	L12	TAP	Change ²⁾
F..27	1.00	1.11	1/4	1.97	0.20	1-5/16	3/8 - 16 x 0.87	0
F..37	1.00	1.11	1/4	1.97	0.20	1-5/16	3/8 - 16 x 0.87	0
F..47	1.25	1.36	1/4	2.36	0.26	1-11/16	1/2 - 13 x 1.12	0
F..57	1.375	1.51	5/16	2.76	0.43	1-13/16	1/2 - 13 x 1.12	0
F..67	1.375	1.51	5/16	2.76	0.47	1-13/16	1/2 - 13 x 1.12	-0.39
	1.625	1.79	3/8	3.15	0.38	2-1/4	5/8 - 11 x 1.38	0
F..77	1.75	1.92	3/8	3.54	0.4	2-3/4	5/8 - 11 x 1.38	-0.39
	2.00	2.22	1/2	3.94	0.64	2-5/8	3/4 - 10 x 1.61	0
F..87	2.375	2.65	5/8	4.72	0.51	3-5/8	3/4 - 10 x 1.61	0
F..97	2.875	3.2	3/4	5.51	0.67	4-1/8	3/4 - 10 x 1.61	0
F..107	3.625	4.01	7/8	6.69	0.63	5-3/8	1 - 8 x 2.13	0
F..127	4.375	4.82	1	8.27	1.09	6	1 - 8 x 2.13	0
F..157	4.75	5.29	1-1/4	8.27	0.82	6-9/16	1 - 8 x 2.13	0

1) Longer shafts to match older designs are available for flanged units.

2) The change in length, L, when compared to the standard shaft that is shown in dimension pages.

9 F - theSnuggler® Helical

Output shaft sizes

9.10.2 Solid shafts - Metric

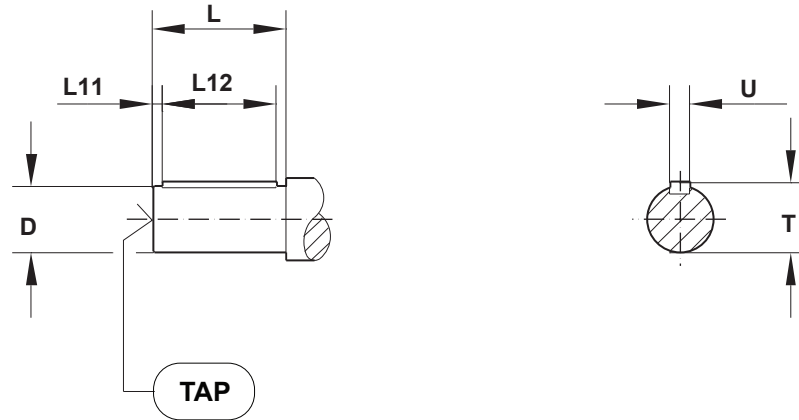

All dimensions in mm							
Model	D	T	U	L ¹⁾	L11	L12	TAP
F..27	25	28	8	50	5	40	M10 x 22
F..37	25	28	8	50	5	40	M10 x 22
F..47	30	33	8	60	3.5	50	M10 x 22
F..57	35	38	10	70	7	56	M12 x 28
F..67	40	43	12	80	5	70	M16 x 36
	35	38	10	70	7	56	M12 x 28
F..77	50	53.5	14	100	10	80	M16 x 36
	45	48.5	14	90	5	80	M16 x 36
F..87	60	64	18	120	5	110	M20 x 42
F..97	70	74.5	20	140	7.5	125	M20 x 42
F..107	90	95	25	170	5	160	M24 x 50
F..127	110	116	28	210	15	180	M24 x 50
F..157	120	127	32	210	5	200	M24 x 50

1) Longer shafts to match older designs are available for flanged units.

9.10.3 Hollow shafts - Inch

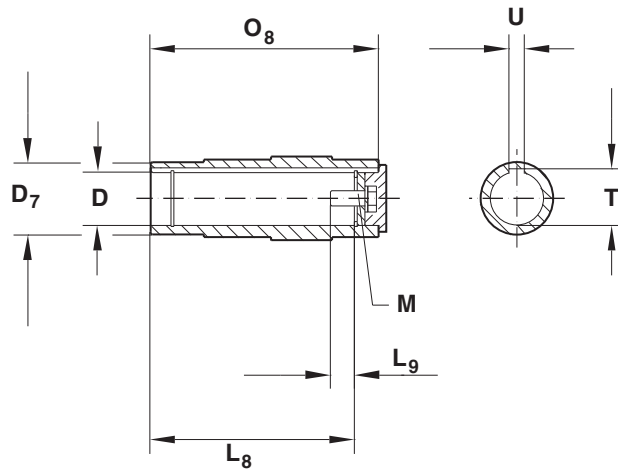

All dimensions in inches								
Model	D	D ₇	O ₈	T	U	L ₈	L ₉	M
FA..27	1.00	1.57	4.09	1.12	1/4	3.50	0.69	3/8 - 16 x 1
FA..37	1.25	1.77	4.72	1.37	1/4	4.13	0.67	7/16 - 14 x 1
FA..47	1.1875	1.97	5.91	1.30	1/4	5.2	0.67	3/8 - 16 x 1
	1.25	1.97	5.91	1.37	1/4	5.2	0.67	7/16 - 14 x 1
	1.375	1.97	5.91	1.52	5/16	5.2	0.65	1/2 - 13 x 1
	1.4375	1.97	5.91	1.61	3/8	5.2	0.65	5/8 - 11 x 1-3/4
FA..57	1.4375	2.17	6.54	1.61	3/8	5.59	1.36	5/8 - 11 x 1-3/4
	1.50	2.17	6.54	1.67	3/8	5.59	1.36	5/8 - 11 x 1-3/4
FA..67	1.4375	2.17	7.09	1.61	3/8	6.14	1.36	5/8 - 11 x 1-3/4
	1.50	2.17	7.09	1.67	3/8	6.14	1.36	5/8 - 11 x 1-3/4
FA..77	1.9375	2.76	8.27	2.16	1/2	7.2	1.16	5/8 - 11 x 1-3/4
	2.00	2.76	8.27	2.22	1/2	7.2	1.16	5/8 - 11 x 1-3/4
FA..87	2.375	3.35	9.45	2.65	5/8	8.27	1.39	3/4 - 10 x 2
	2.4375	3.35	9.45	2.62	5/8	8.27	1.39	3/4 - 10 x 2
FA..97	2.75	3.74	11.81	3.03	5/8	10.63	1.24	3/4 - 10 x 2
	2.9375	3.74	11.81	3.14	3/4	10.63	1.24	3/4 - 10 x 2
FA..107	3.25	4.65	13.78	3.59	3/4	12.32	1.24	3/4 - 10 x 2
	3.4375	4.65	13.78	3.7	7/8	12.32	1.24	3/4 - 10 x 2
	3.625	4.65	13.78	3.89	7/8	12.32	1.24	3/4 - 10 x 2
FA..127	4.00	5.31	16.14	4.44	1	14.69	1.26	1 - 8 x 2-1/4
FA..157	4.50	6.1	19.69	4.95	1	18.11	1.26	1 - 8 x 2-1/4

9.10.4 Hollow shafts - Metric

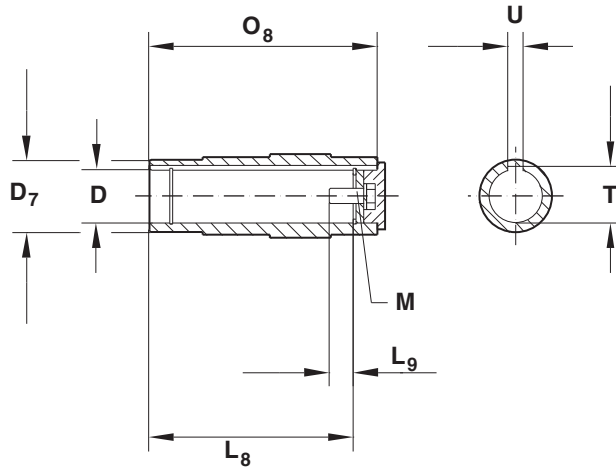

All dimensions in mm								
Model	D	D ₇	O ₈	T	U	L ₈	L ₉	M
FA..27	25	40	104	28.3	8	89	17	M10 x 25
FA..37	30	45	120	33.3	8	105	17	M10 x 25
FA..47	35	50	150	38.3	10	132	22	M12 x 30
	30	50	150	33.3	8	132	16	M10 x 25
FA..57	40	55	166	43.3	12	142	29	M16 x 40
FA..67	40	55	180	43.3	12	156	29	M16 x 40
FA..77	50	70	210	53.8	14	183	32	M16 x 45
FA..87	60	85	240	64.4	18	210	36	M20 x 50
FA..97	70	95	300	74.9	20	270	34	M20 x 50
FA..107	90	118	350	95.4	25	313	40	M24 x 60
	80	118	350	85.4	22	313	30	M20 x 50
FA..127	100	135	410	106.4	28	373	38	M24 x 60
FA..157	120	135	500	127.4	32	460	36	M24 x 60

9.10.5 TorqLOC keyless hollow shaft

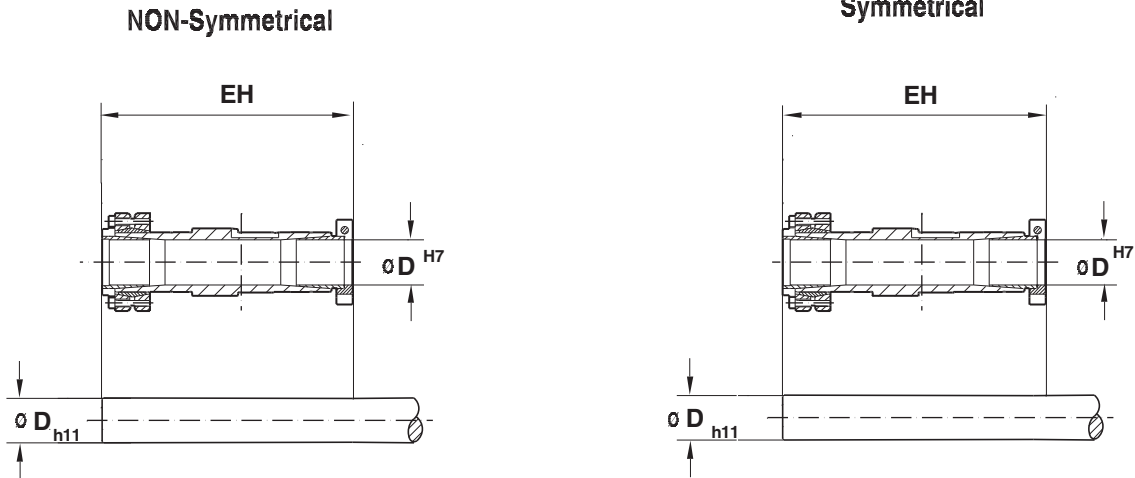

Metric and inch bores are available as shown below.

Model	D (in)					D (mm)			EH (inches)	
	Inch Bores					Metric Bores			NON-Symmetrical	Symmetrical
FT37	1.00	1.1875	1.25	-	-	25	30	-	6.69	7.60
FT47	1.1875	1.25	1.375	1.4375	-	30	35	-	8.15	9.09
FT57	1.375	1.4375	1.50	1.625	-	35	38	40	9.13	10.33
FT67	1.375	1.4375	1.50	1.625	1.688	35	38	40	9.65	10.85
FT77	1.625	1.75	1.9375	2.00	-	50	-	-	11.57	13.21
FT87	1.9375	2.00	2.375	2.4375	-	51	62	65	13.19	15.24
FT97	2.4375	2.75	2.9375	-	-	62	70	75	15.59	17.76
FT107	3.250	3.4375	3.625	3.750	-	80	90	95	17.76	20.09
FT127	3.4375	3.750	4.00	4.1875	-	105	-	-	20.94	23.89
FT157	4.4375	4.50	4.9375	5.00	-	110	125	-	25.24	28.39

9 F - theSnuggler® Helical

Output shaft sizes

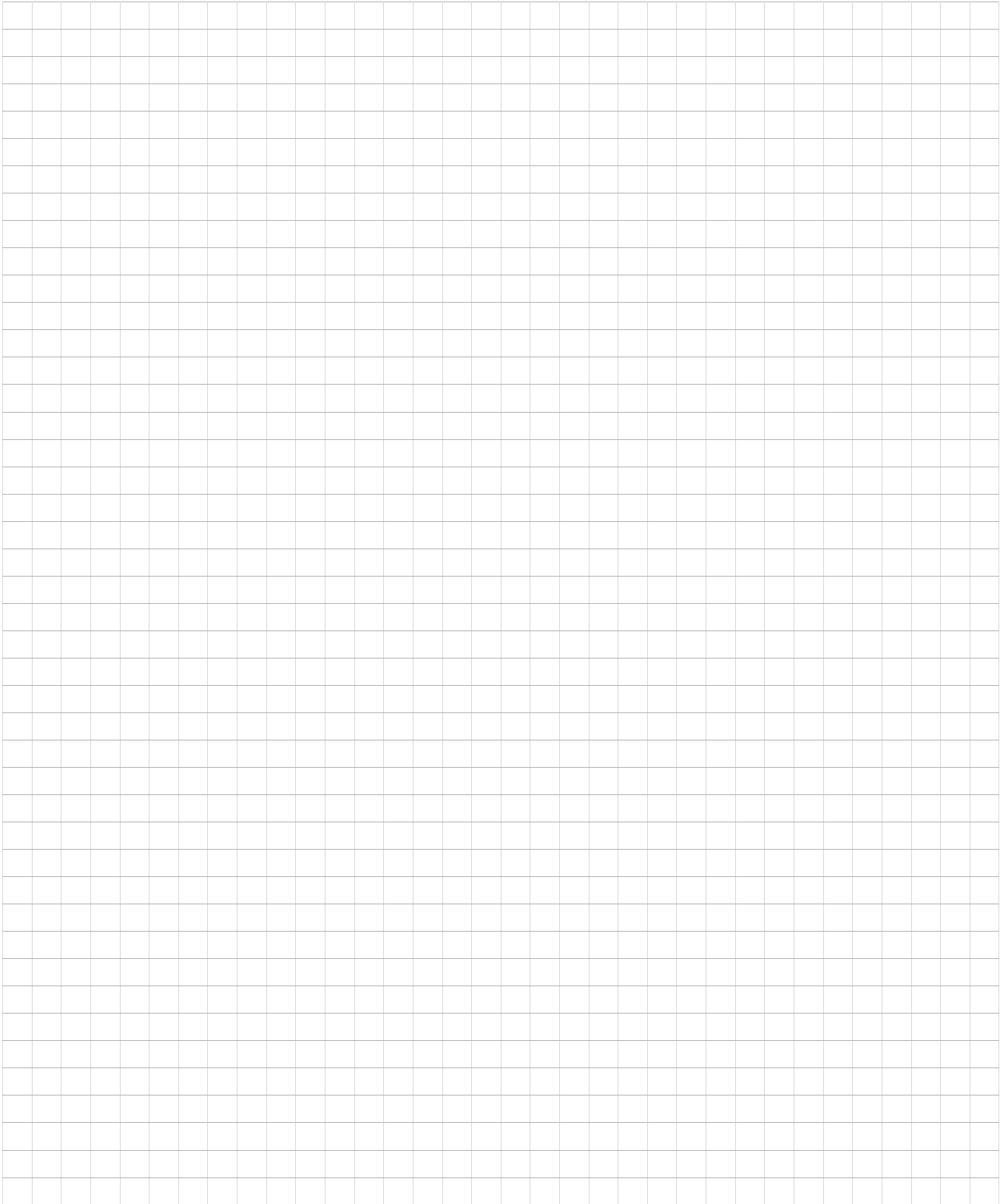

10 K - Helical Bevel

10.1 K.. AM

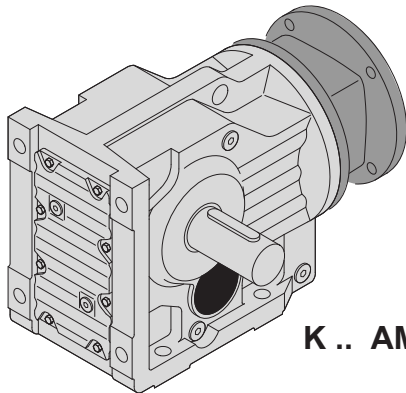

K .. AM..

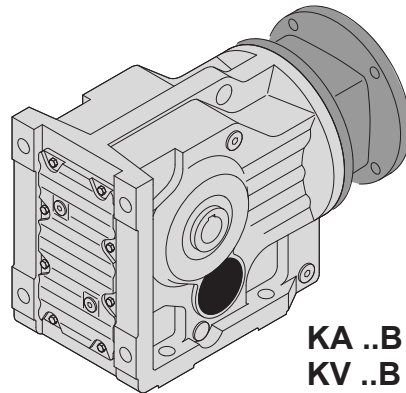

KA ..B AM..
KV ..B AM..

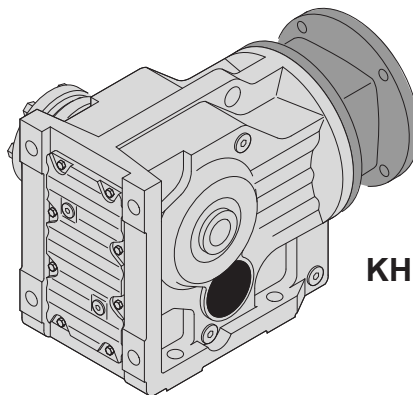

KH ..B AM..

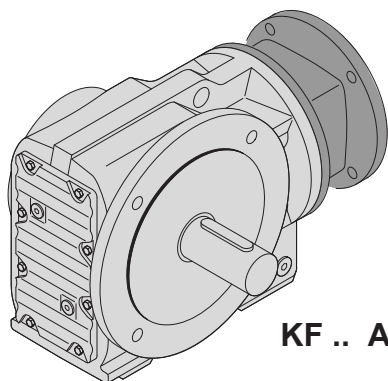

KF .. AM..

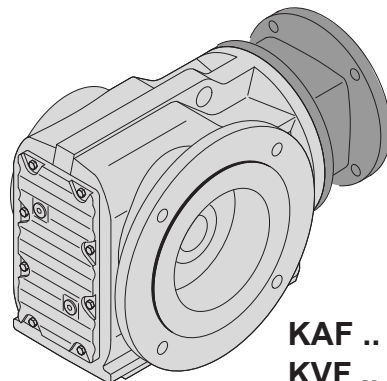

KAF .. AM..
KVF .. AM ..

50405AXX

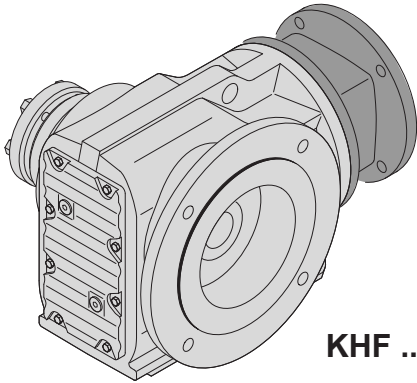

KHF .. AM..

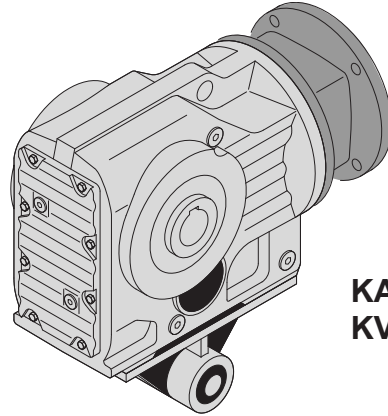

**KA../T AM..
KV../T AM..**

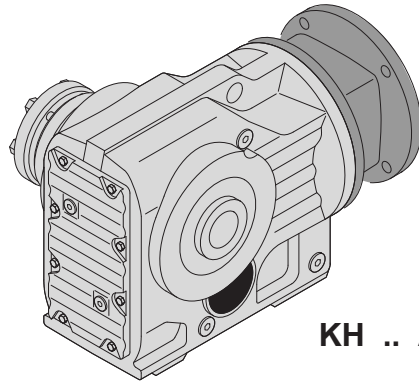

KH .. AM..

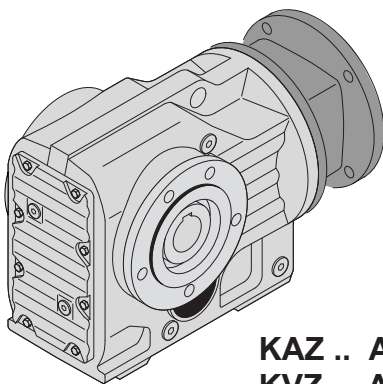

**KAZ .. AM..
KVZ .. AM..**

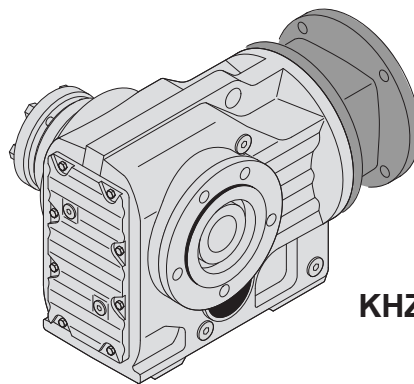

KHZ .. AM..

50406AXX

10.1.1 K19

K19, n _e = 1700 rpm						705 lb-in		
Stages	i [ratio]	n _a [rpm]	T _{a max} [lb-in]	F _{Ra} [lb]	φ (/R) [']	56	AM 143	145
K19  2	4.50	378	705	415	-			
	5.16	329	705	440	-			
	5.54	307	705	455	-			
	6.41	265	705	485	-			
	6.91	246	705	500	-			
	8.09	210	705	535	-			
	9.58	177	555	605	-			
	10.32	165	670	560	-			
	11.84	144	695	590	-			
	12.70	134	705	605	-			
	14.69	116	705	645	-			
	15.84	107	705	665	-			
	18.55	92	705	710	-			
	21.98	77	705	765	-			
	24.06	71	705	790	-			
	26.88	63	705	830	-			
	27.16	63	530	850	-			
	29.14	58	705	860	-			
	29.29	58	535	870	-			
	31.74	54	705	890	-			
34.29	50	565	920	-				
40.63	42	590	980	-				
44.48	38	610	970	-				
49.69	34	615	970	-				
53.88	32	615	970	-				
58.68	29	615	970	-				

10

Weight [lbs]		Stages	56	AM 143	145
K19	NEMA	2	16	20	20
			71	80	90
	IEC	2	16	20	20

KA19: -0.5 lbs / KAF19: +0 lbs / KF19: +1.0 lbs

10 K - Helical Bevel

K.. AM

10.1.2 K29

K29, n _e = 1700 rpm						1150 lb-in		
Stages	i [ratio]	n _a [rpm]	T _{a max} [lb-in]	F _{Ra} [lb]	Φ (/R) [']	AM		
						56	143	145
K29  2	3.19	533	970	375	-			
	3.92	434	1110	390	-			
	5.10	333	970	465	-			
	5.75	296	990	490	-			
	6.95	245	990	530	-			
	7.48	227	1080	470	-			
	8.53	199	1070	565	-			
	9.17	185	1150	505	-			
	9.90	172	970	620	-			
	11.94	142	1150	575	-			
	13.47	126	1150	610	-			
	16.29	104	1150	665	-			
	19.99	85	1150	730	-			
	22.08	77	920	790	-			
	23.19	73	1150	780	-			
	24.91	68	960	820	-			
	27.23	62	1150	840	-			
	29.69	57	1150	870	-			
	30.11	56	1010	880	-			
	33.15	51	1150	910	-			
	35.83	47	1150	940	-			
	36.96	46	1070	940	-			
	38.90	44	1150	980	-			
	42.87	40	1130	990	-			
50.35	34	1150	1060	-				
54.89	31	1150	1100	-				
61.28	28	1150	1130	-				
66.25	26	1150	1130	-				
71.93	24	1150	1130	-				

Weight [lbs]		Stages	AM		
			56	143	145
K29	NEMA	2	19	23	23
			71	80	90
	IEC	2	18	23	23

KA29: -0 lbs / KAF29: +2 lbs / KF29: +2.5 lbs

10.1.3 K37

K37, n _e = 1700 rpm						1760 lb-in		
Stages	i [ratio]	n _a [rpm]	T _{a max} [lb-in]	F _{Ra} [lb]	Φ (/R) [']	56	AM 143	145
 K37 3	3.98	427	1100	335	13			
	5.36	317	1230	365	13			
	6.37	267	1280	390	13			
	6.80	250	1320	395	13			
	7.96	214	1370	425	13			
	8.91	191	1410	445	12			
	10.49	162	1410	485	12			
	12.14	140	1410	525	12			
	13.08	130	1450	535	9			
	15.31	111	1540	565	8			
	17.15	99	1590	590	8			
	20.19	84	1630	630	8			
	23.36	73	1720	660	8			
	24.99	68	1760	675	8			
	28.83	59	1760	730	8			
	29.96	57	1760	745	7			
	35.57	48	1760	810	7			
	37.97	45	1760	840	7			
	44.46	38	1760	900	7			
	49.79	34	1760	960	7			
58.60	29	1760	1030	7				
67.80	25	1760	1100	7				
72.54	23	1760	1140	7				
83.69	20	1760	1210	7				
97.81	17	1760	1270	7				
106.38	16	1760	1270	7				

Weight [lbs]		Stages	56	AM 143	145
K37	NEMA	3	33	37	37
			71	80	90
	IEC	3	32	37	37

KA37: -0.5 lbs / KAF37: +3 lbs / KF37: +5 lbs

10.1.4 K39

K39, n _e = 1700 rpm						2660 lb-in				
Stages	i [ratio]	n _a [rpm]	T _{a max} [lb-in]	F _{Ra} [lb]	Φ (/R) [']	56	143	AM 145	182	184
K39  2	2.81	605	1130	650	-					
	3.94	431	1510	690	-					
	4.52	376	1690	700	-					
	5.22	326	1860	730	-					
	5.75	296	1990	740	-					
	6.75	252	2260	760	-					
	7.15	238	2350	760	-					
	8.12	209	2520	790	-					
	9.00	189	2660	810	-					
	10.61	160	2520	890	-					
	12.09	141	1650	1080	-					
	12.73	134	1700	1090	-					
	13.44	126	2390	840	-					
	15.44	110	2480	890	-					
	17.83	95	2570	940	-					
	19.62	87	2610	980	-					
	23.04	74	2660	1050	-					
	24.40	70	2660	1090	-					
	27.73	61	2660	1160	-					
	30.72	55	2660	1220	-					
36.22	47	2660	1320	-						
41.28	41	2660	1410	-						
43.45	39	2660	1440	-						
49.69	34	2660	1530	-						
58.24	29	2660	1650	-						

Weight [lbs]		Stages	56	143	AM 145	182	184
K39	NEMA	2	45	49	49	57	57
			71	80	90	100	112
	IEC	2	44	49	49	59	59

KA39: -2 lbs / KAF39: +1 lbs / KF39: +3 lbs

10.1.5 K47

K47, n _e = 1700 rpm						3530 lb-in				
Stages	i [ratio]	n _a [rpm]	T _{a max} [lb-in]	F _{Ra} [lb]	φ (/R) [']	56	143	AM 145	182	184
K47  3	4.64	366	1810	605	12					
	5.81	293	2030	635	12					
	6.58	258	2120	660	12					
	7.36	231	2210	685	11					
	8.56	199	2380	705	11					
	9.10	187	2470	715	11					
	10.56	161	2470	775	11					
	11.77	144	2470	820	10					
	12.19	139	3090	745	8					
	13.65	125	3180	780	8					
	15.86	107	3360	820	8					
	16.86	101	3360	850	8					
	19.58	87	3530	890	8					
	21.81	78	3530	950	8					
	24.06	71	3530	1000	8					
	25.91	66	3530	1050	8					
	29.32	58	3530	1120	8					
	31.30	54	3530	1160	7					
	35.39	48	3530	1240	7					
	39.61	43	3530	1310	7					
	46.03	37	3530	1330	7					
	48.95	35	3530	1330	7					
	56.83	30	3530	1330	7					
	63.30	27	3530	1330	6					
	69.84	24	3530	1330	6					
	75.20	23	3530	1330	6					
85.12	20	3530	1330	6						
90.86	19	3530	1330	6						
104.37	16	3530	1330	6						
121.48	14	3530	1330	6						
131.87	13	3530	1330	6						

Weight [lbs]		Stages	56	143	AM 145	182	184
K47	NEMA	3	48	52	52	60	60
			71	80	90	100	112
	IEC	3	47	52	52	62	62

KA47: -2 lbs / KAF47: +4.5 lbs / KF47: +7 lbs

10

10 K - Helical Bevel

K.. AM

10.1.6 K47R37

K47R37, $n_e = 1700$ rpm							3540 lb-in		
i [ratio]	n_a [rpm]	$T_{a\ max}$ [lb-in]	$F_{Ra}^{(1)}$ [lb]	Stages		ϕ (/R) [']	56	AM	
				Lg	Sm			143	145
94	18	3540	1330	3	2	-			
99	17	3540	1330	3	2	-			
112	15	3540	1330	3	2	-			
131	13	3540	1330	3	2	-			
153	11	3540	1330	3	2	-			
171	9.9	3540	1330	3	2	-			
198	8.6	3540	1330	3	2	-			
225	7.6	3540	1330	3	2	-			
256	6.6	3540	1330	3	2	-			
289	5.9	3540	1330	3	2	-			
327	5.2	3540	1330	3	2	-			
375	4.5	3540	1330	3	2	-			
426	4.0	3540	1330	3	2	-			
495	3.4	3540	1330	3	2	-			
552	3.1	3540	1330	3	2	-			
639	2.7	3540	1330	3	2	-			
718	2.4	3540	1330	3	2	-			
831	2.0	3540	1330	3	2	-			
945	1.8	3540	1330	3	2	-			
1097	1.5	3540	1330	3	2	-			
1222	1.4	3540	1330	3	2	-			
1388	1.2	3540	1330	3	3	-			
1586	1.1	3540	1330	3	3	-			
1819	0.93	3540	1330	3	3	-			
2063	0.82	3540	1330	3	3	-			
2354	0.72	3540	1330	3	3	-			
2733	0.62	3540	1330	3	3	-			
3043	0.56	3540	1330	3	3	-			
3477	0.49	3540	1330	3	3	-			
3940	0.43	3540	1330	3	3	-			
4601	0.37	3540	1330	3	3	-			
5159	0.33	3540	1330	3	3	-			
5983	0.28	3540	1330	3	3	-			
6826	0.25	3540	1330	3	3	-			
7662	0.22	3540	1330	3	3	-			
8534	0.20	3540	1330	3	3	-			
10138	0.17	3540	1330	3	3	-			

Weight [lbs]		Stages		56	AM	
		Large	Small		143	145
K47R37	NEMA	3	2	71	75	75
		3	3	71	76	76
				71	80	90
	IEC	3	2	70	75	75
		3	3	70	76	76

KA47: -2 lbs / KAF47: +4.5 lbs / KF47: +7 lbs

10.1.7 K49

K49, n _e = 1700 rpm						4430 lb-in					
Stages	i [ratio]	n _a [rpm]	T _{a max} [lb-in]	F _{Ra} [lb]	φ (/R) [']	AM					
						56	143	145	182	184	213/215
K49  2	4.00	425	3850	430	-						
	4.69	362	4120	420	-						
	5.29	321	4290	460	-						
	5.99	284	4430	580	-						
	6.83	249	4430	780	-						
	7.58	224	4430	820	-						
	8.66	196	4430	880	-						
	9.14	186	4430	910	-						
	10.42	163	4250	1090	-						
	11.37	150	4380	1120	-						
	13.38	127	4160	860	-						
	15.67	108	4340	920	-						
	17.67	96	4430	970	-						
	20.03	85	4430	1050	-						
	22.83	74	4430	1130	-						
	25.34	67	4430	1200	-						
	28.95	59	4430	1290	-						
	30.55	56	4430	1330	-						
	34.81	49	4430	1420	-						
	37.98	45	4430	1490	-						
44.44	38	4430	1610	-							
50.29	34	4430	1720	-							
52.94	32	4430	1760	-							
60.27	28	4430	1870	-							
70.19	24	3940	2020	-							
75.20	23	4200	2020	-							

10

Weight [lbs]		Stages	AM					
			56	143	145	182	184	213/215
K49	NEMA	2	72	76	76	84	84	96
			71	80	90	100	112	132S/M
	IEC	2	71	76	76	86	86	103

KA49: -6 lbs / KAF49: +5 lbs / KF49: +4 lbs

10 K - Helical Bevel

K.. AM

10.1.8 K49R37

K49R37, $n_e = 1700$ rpm							4430 lb-in		
i [ratio]	n_a [rpm]	T_a max [lb-in]	$F_{Ra}^{(1)}$ [lb]	Stages		ϕ (/R) [']	AM		
				Lg	Sm		56	143	145
99	17	4430	2020	2	2	-			
125	14	4430	2020	2	2	-			
152	11	4430	2020	2	2	-			
176	9.7	4430	2020	2	2	-			
193	8.8	4430	2020	2	2	-			
217	7.8	4430	2020	2	2	-			
243	7.0	4430	2020	2	2	-			
274	6.2	4430	2020	2	2	-			
300	5.7	4430	2020	2	2	-			
330	5.2	4430	2020	2	2	-			
360	4.7	4430	2020	2	2	-			
401	4.2	4430	2020	2	2	-			
449	3.8	4430	2020	2	2	-			
501	3.4	4430	2020	2	2	-			
543	3.1	4430	2020	2	2	-			
595	2.9	4430	2020	2	2	-			
645	2.6	4430	2020	2	2	-			
701	2.4	4430	2020	2	2	-			
802	2.1	4430	2020	2	2	-			
908	1.9	4430	2020	2	2	-			
1000	1.7	4430	2020	2	3	-			
1120	1.5	4430	2020	2	2	-			
1228	1.4	4430	2020	2	3	-			
1309	1.3	4430	2020	2	2	-			
1424	1.2	4430	2020	2	2	-			
1521	1.1	4430	2020	2	3	-			
1632	1.0	4430	2020	2	3	-			
1741	0.98	4430	2020	2	3	-			
1941	0.88	4430	2020	2	3	-			
2118	0.80	4430	2020	2	3	-			
2372	0.72	4430	2020	2	3	-			
2545	0.67	4430	2020	2	3	-			
2773	0.61	4430	2020	2	3	-			
3081	0.55	4430	2020	2	3	-			
3580	0.47	4430	2020	2	3	-			
4034	0.42	4430	2020	2	3	-			
5120	0.33	4430	2020	2	3	-			
5991	0.28	4430	2020	2	3	-			
7137	0.24	4430	2020	2	3	-			

Weight [lbs]		Stages		AM		
		Large	Small	56	143	145
K49R37	NEMA	2	2	92	96	96
		2	3	93	97	97
			71	80	90	
	IEC	2	2	91	96	96
		2	3	92	97	97
	KA49: -6 lbs / KAF49: +5 lbs / KF49: +4 lbs					

10.1.9 K57

K57, n _e = 1700 rpm						5310 lb-in					
Stages	i [ratio]	n _a [rpm]	T _{a max} [lb-in]	F _{Ra} [lb]	Φ (/R) [']	AM					
						56	143	145	182	184	213/215
 K57	4.69	362	2650	770	11						
	6.57	259	3050	850	10						
	7.55	225	3220	880	10						
	8.71	195	3450	910	10						
	9.59	177	3580	940	10						
	11.26	151	3670	1010	9						
	11.92	143	3670	1040	9						
	13.25	128	4510	1050	7						
	15.22	112	4730	1090	7						
	17.57	97	4910	1160	7						
	19.34	88	5080	1190	7						
	22.71	75	5310	1270	7						
	24.05	71	5310	1310	7						
	27.34	62	5310	1400	7						
	30.28	56	5310	1480	7						
	35.70	48	5310	1620	7						
	38.49	44	5310	1680	6						
	44.43	38	5310	1720	6						
	48.89	35	5310	1720	6						
	57.42	30	5310	1720	6						
	60.81	28	5310	1720	6						
	69.12	25	5310	1720	6						
	76.56	22	5310	1720	6						
	90.26	19	5310	1720	6						
102.88	17	5310	1720	6							
108.29	16	5310	1720	6							
123.85	14	5310	1720	6							
145.14	12	5310	1720	6							

10

Weight [lbs]		Stages	AM					
			56	143	145	182	184	213/215
K57	NEMA	3	61	65	65	73	73	85
			71	80	90	100	112	132S/M
	IEC	3	60	65	65	75	75	91

KA57: -5 lbs / KAF57: +8 lbs / KF57: +10 lbs

10 K - Helical Bevel

K.. AM

10.1.10 K57R37

K57R37, $n_e = 1700$ rpm							5310 lb-in		
i [ratio]	n_a [rpm]	$T_{a\ max}$ [lb-in]	$F_{Ra}^{(1)}$ [lb]	Stages		ϕ (/R) [']	56	AM	
				Lg	Sm			143	145
97	18	5310	1720	3	2	-			
111	15	5310	1720	3	2	-			
129	13	5310	1720	3	2	-			
145	12	5310	1720	3	2	-			
166	10	5310	1720	3	2	-			
192	8.9	5310	1720	3	2	-			
215	7.9	5310	1720	3	2	-			
246	6.9	5310	1720	3	2	-			
280	6.1	5310	1720	3	2	-			
319	5.3	5310	1720	3	2	-			
362	4.7	5310	1720	3	2	-			
421	4.0	5310	1720	3	2	-			
473	3.6	5310	1720	3	2	-			
544	3.1	5310	1720	3	2	-			
615	2.8	5310	1720	3	2	-			
699	2.4	5310	1720	3	2	-			
806	2.1	5310	1720	3	2	-			
906	1.9	5310	1720	3	2	-			
1036	1.6	5310	1720	3	2	-			
1174	1.4	5310	1720	3	2	-			
1354	1.3	5310	1720	3	2	-			
1539	1.1	5310	1720	3	2	-			
1743	0.98	5310	1720	3	2	-			
1986	0.86	5310	1720	3	3	-			
2249	0.76	5310	1720	3	3	-			
2593	0.66	5310	1720	3	3	-			
2924	0.58	5310	1720	3	3	-			
3390	0.50	5310	1720	3	3	-			
3854	0.44	5310	1720	3	3	-			
4340	0.39	5310	1720	3	3	-			
5033	0.34	5310	1720	3	3	-			
5662	0.30	5310	1720	3	3	-			
6478	0.26	5310	1720	3	3	-			
7277	0.23	5310	1720	3	3	-			
8547	0.20	5310	1720	3	3	-			
9503	0.18	5310	1720	3	3	-			
11162	0.15	5310	1720	3	3	-			
12169	0.14	5310	1720	3	3	-			

Weight [lbs]		Stages		56	AM	
		Large	Small		143	145
K57R37	NEMA	3	2	84	88	88
		3	3	84	89	89
				71	80	90
	IEC	3	2	83	88	88
3		3	83	89	89	

KA57: -5 lbs / KAF57: +8 lbs / KF57: +10 lbs

10.1.11 K67

K67, n _e = 1700 rpm						7260 lb-in					
Stages	i [ratio]	n _a [rpm]	T _{a max} [lb-in]	F _{Ra} [lb]	Φ (i/R) [']	AM					
						56	143	145	182	184	213/215
 K67	5.20	327	3090	2060	10						
	7.28	234	3710	2230	9						
	8.37	203	3890	2320	9						
	9.66	176	4240	2390	9						
	10.63	160	4420	2460	9						
	12.48	136	4680	2570	9						
	13.22	129	5920	2560	8						
	15.19	112	6190	2530	8						
	17.54	97	6540	2470	7						
	19.30	88	6720	2430	7						
	22.66	75	6900	2390	7						
	24.00	71	7070	2360	7						
	27.28	62	7260	2320	7						
	30.22	56	7260	2320	7						
	35.62	48	7260	2320	7						
	38.39	44	7260	2360	6						
	44.32	38	7260	2320	6						
	48.77	35	7260	2320	6						
	57.28	30	7260	2320	6						
	60.66	28	7260	2320	6						
68.95	25	7260	2320	6							
76.37	22	7260	2320	6							
90.04	19	7260	2320	6							
102.62	17	7260	2320	6							
108.03	16	7260	2320	6							
123.54	14	7260	2320	6							
144.79	12	7260	2320	6							

Weight [lbs]	Stages	AM						
		56	143	145	182	184	213/215	
K67	NEMA	3	73	78	78	86	86	98
			71	80	90	100	112	132S/M
	IEC	3	73	78	78	88	88	105

KA67: -6 lbs / KAF67: +7 lbs / KF67: +12 lbs

10 K - Helical Bevel

K.. AM

10.1.12 K67R37

K67R37, $n_e = 1700$ rpm							7260 lb-in		
i [ratio]	n_a [rpm]	T_a max [lb-in]	$F_{Ra}^{1)}$ [lb]	Stages		ϕ (/R) [']	AM		
				Lg	Sm		56	143	145
122	14	7260	2320	3	2	-			
144	12	7260	2320	3	2	-			
166	10	7260	2320	3	2	-			
191	8.9	7260	2320	3	2	-			
217	7.8	7260	2320	3	2	-			
246	6.9	7260	2320	3	2	-			
279	6.1	7260	2320	3	2	-			
323	5.3	7260	2320	3	2	-			
361	4.7	7260	2320	3	2	-			
420	4.0	7260	2320	3	2	-			
471	3.6	7260	2320	3	2	-			
542	3.1	7260	2320	3	2	-			
613	2.8	7260	2320	3	2	-			
697	2.4	7260	2320	3	2	-			
793	2.1	7260	2320	3	2	-			
903	1.9	7260	2320	3	2	-			
1034	1.6	7260	2320	3	2	-			
1171	1.5	7260	2320	3	2	-			
1351	1.3	7260	2320	3	2	-			
1535	1.1	7260	2320	3	2	-			
1739	0.98	7260	2320	3	2	-			
1981	0.86	7260	2320	3	3	-			
2244	0.76	7260	2320	3	3	-			
2532	0.67	7260	2320	3	3	-			
2917	0.58	7260	2320	3	3	-			
3315	0.51	7260	2320	3	3	-			
3750	0.45	7260	2320	3	3	-			
4329	0.39	7260	2320	3	3	-			
4846	0.35	7260	2320	3	3	-			
5648	0.30	7260	2320	3	3	-			
6462	0.26	7260	2320	3	3	-			
7259	0.23	7260	2320	3	3	-			
8173	0.21	7260	2320	3	3	-			
9479	0.18	7260	2320	3	3	-			
11134	0.15	7260	2320	3	3	-			
12139	0.14	7260	2320	3	3	-			

Weight [lbs]		Stages		56	AM 143	145
		Large	Small			
K67R37	NEMA	3	2	97	100	100
		3	3	97	100	100
			71	80	90	
	IEC	3	2	96	100	100
		3	3	96	100	100

KA67: -6 lbs / KAF67: +7 lbs / KF67: +12 lbs

10.1.13 K77

K77, n _e = 1700 rpm						13720 lb-in					
Stages	i [ratio]	n _a [rpm]	T _{a max} [lb-in]	F _{Ra} [lb]	Φ (/R) [']	AM					
						56	143	145	182	184	213/215
K77  3	7.24	235	7250	2710	8						
	8.48	200	7870	2810	8						
	9.56	178	8310	2890	8						
	10.84	157	8750	2990	8						
	12.36	138	8840	3140	8						
	13.52	126	11800	3060	7						
	15.84	107	12300	3210	6						
	17.87	95	12800	3330	6						
	20.25	84	13200	3460	6						
	23.08	74	13720	3460	6						
	25.62	66	13720	3460	6						
	29.27	58	13720	3460	6						
	30.89	55	13720	3460	6						
	35.20	48	13720	3460	6						
	38.39	44	13720	3530	6						
	40.04	42	13720	3460	6						
	45.16	38	13720	3460	6						
	51.18	33	13720	3460	6						
	58.34	29	13720	3460	6						
	64.75	26	13720	3460	5						
	73.99	23	13720	3460	5						
	78.07	22	13720	3460	5						
	88.97	19	13720	3460	5						
	97.05	18	13720	3460	5						
113.56	15	13720	3460	5							
128.52	13	13720	3460	5							
135.28	13	13720	3460	5							
154.02	11	13720	3460	5							
179.37	9.5	12800	3610	5							
192.18	8.8	12800	3610	5							

Weight [lbs]		Stages	AM					
			56	143	145	182	184	213/215
K77	NEMA	3	130	130	130	140	140	155
			71	80	90	100	112	132S/M
	IEC	3	125	130	130	140	140	155

KA77: -17 lbs / KAF77: +1 lb / KF77: +18 lbs

10 K - Helical Bevel

K.. AM

10.1.14 K77R37

K77R37, $n_e = 1700$ rpm							13720 lb-in		
i [ratio]	n_a [rpm]	$T_{a\ max}$ [lb-in]	$F_{Ra}^{(1)}$ [lb]	Stages		ϕ (/R) [']	AM		
				Lg	Sm		56	143	145
154	11	13720	3460	3	2	-			
175	9.7	13720	3460	3	2	-			
195	8.7	13720	3460	3	2	-			
221	7.7	13720	3460	3	2	-			
252	6.7	13720	3460	3	2	-			
290	5.9	13720	3460	3	2	-			
328	5.2	13720	3460	3	2	-			
367	4.6	13720	3460	3	2	-			
428	4.0	13720	3460	3	2	-			
485	3.5	13720	3460	3	2	-			
552	3.1	13720	3460	3	2	-			
622	2.7	13720	3460	3	2	-			
709	2.4	13720	3460	3	2	-			
815	2.1	13720	3460	3	2	-			
924	1.8	13720	3460	3	2	-			
1053	1.6	13720	3460	3	2	-			
1218	1.4	13720	3460	3	2	-			
1388	1.2	13720	3460	3	2	-			
1514	1.1	13720	3460	3	2	-			
1772	0.96	13720	3460	3	2	-			
2050	0.83	13720	3460	3	2	-			
2370	0.72	13720	3460	3	3	-			
2717	0.63	13720	3460	3	3	-			
2901	0.59	13720	3460	3	3	-			
3485	0.49	13720	3460	3	3	-			
3961	0.43	13720	3460	3	3	-			
4489	0.38	13720	3460	3	3	-			
5089	0.33	13720	3460	3	3	-			
5774	0.29	13720	3460	3	3	-			
6606	0.26	13720	3460	3	3	-			
7528	0.23	13720	3460	3	3	-			
8809	0.19	13720	3460	3	3	-			
10217	0.17	13720	3460	3	3	-			
11955	0.14	13720	3460	3	3	-			
14043	0.12	13720	3460	3	3	-			
15310	0.11	13720	3460	3	3	-			
154	11	13720	3460	3	2	-			
175	9.7	13720	3460	3	2	-			
195	8.7	13720	3460	3	2	-			
221	7.7	13720	3460	3	2	-			
252	6.7	13720	3460	3	2	-			
290	5.9	13720	3460	3	2	-			

Weight [lbs]		Stages		AM		
		Large	Small	56	143	145
K77R37	NEMA	3	2	150	155	155
		3	3	150	155	155
	IEC			71	80	90
		3	2	150	155	155
		3	3	150	155	155

KA77: -17 lbs / KAF77: +1 lb / KF77: +18 lbs

10.1.15 K87

K87, n _e = 1700 rpm						23900 lb-in						
Stages	i [ratio]	n _a [rpm]	T _{a max} [lb-in]	F _{Ra} [lb]	φ (/R) [']	AM						
						143	145	182	184	213/215	254/256	284/286
 K87 3	7.21	236	11500	2720	7							
	8.29	205	12300	2780	7							
	10.00	170	13200	2920	7							
	11.17	152	13200	3080	7							
	12.56	135	17600	3030	6							
	14.45	118	18500	3150	6							
	16.00	106	15900	3290	6							
	17.42	98	19400	3350	6							
	19.45	87	20300	3440	6							
	22.41	76	20300	3680	6							
	24.92	68	22100	3680	6							
	27.88	61	23000	3790	6							
	31.39	54	23900	3930	6							
	36.52	47	22100	4400	6							
	44.02	39	23000	4700	6							
	49.16	35	23900	4840	5							
	56.64	30	23900	5160	5							
	63.00	27	23900	5410	5							
	70.46	24	23900	5670	5							
	79.34	21	23900	5970	5							
86.34	20	23900	6130	5								
102.71	17	23900	6130	5								
115.82	15	23900	6130	5								
126.91	13	23900	6130	5								
147.32	12	23900	6130	5								
164.34	10	23900	6130	5								
174.19	9.8	23900	6130	5								
197.37	8.6	23900	6130	5								

Weight [lbs]		Stages	AM						
			143	145	182	184	213/215	254/256	284/286
K87	NEMA	3	210	210	220	220	235	260	265
			80	90	100	112	132S/M	160	180
	IEC	3	210	210	220	220	240	275	275

KA87: -27 lbs / KAF87: +2 lbs / KF87: +20 lbs

10 K - Helical Bevel

K.. AM

10.1.16 K87R57

K87R57, $n_e = 1700$ rpm							23900 lb-in					
i [ratio]	n_a [rpm]	$T_{a\ max}$ [lb-in]	$F_{Ra}^{(1)}$ [lb]	Stages		ϕ (/R) [']	AM					
				Lg	Sm		56	143	145	182	184	213/215
141	12	23010	6160	3	2	-						
159	11	23900	6130	3	2	-						
183	9.3	23900	6130	3	2	-						
201	8.5	23900	6130	3	2	-						
236	7.2	23900	6130	3	2	-						
250	6.8	23900	6130	3	2	-						
294	5.8	23900	6130	3	2	-						
330	5.2	23900	6130	3	2	-						
373	4.6	23900	6130	3	2	-						
426	4.0	23900	6130	3	2	-						
474	3.6	23900	6130	3	2	-						
562	3.0	23900	6130	3	2	-						
638	2.7	23900	6130	3	2	-						
726	2.3	23900	6130	3	2	-						
837	2.0	23900	6130	3	2	-						
951	1.8	23900	6130	3	2	-						
1078	1.6	23900	6130	3	2	-						
1229	1.4	23900	6130	3	2	-						
1415	1.2	23900	6130	3	2	-						
1657	1.0	23900	6130	3	2	-						
1854	0.92	23900	6130	3	2	-						
2088	0.81	23900	6130	3	2	-						
2371	0.72	23900	6130	3	3	-						
2728	0.62	23900	6130	3	3	-						
3107	0.55	23900	6130	3	3	-						
3609	0.47	23900	6130	3	3	-						
4037	0.42	23900	6130	3	3	-						
4562	0.37	23900	6130	3	3	-						
5240	0.32	23900	6130	3	3	-						
5930	0.29	23900	6130	3	3	-						
6832	0.25	23900	6130	3	3	-						
7854	0.22	23900	6130	3	3	-						
9073	0.19	23900	6130	3	3	-						
10217	0.17	23900	6130	3	3	-						
11737	0.14	23900	6130	3	3	-						
13168	0.13	23900	6130	3	3	-						
14829	0.11	23900	6130	3	3	-						

Weight [lbs]		Stages		AM					
		Large	Small	56	143	145	182	184	213/215
K87R57	NEMA	3	2	260	260	260	270	270	285
		3	3	260	265	265	270	270	285
			71	80	90	100	112	132S/M	
	IEC	3	2	255	260	260	270	270	290
3		3	260	265	265	275	275	290	

KA87: -27 lbs / KAF87: +2 lbs / KF87: +20 lbs

10.1.17 K97

K97, n _e = 1700 rpm						38100 lb-in						
Stages	i [ratio]	n _a [rpm]	T _{a max} [lb-in]	F _{Ra} [lb]	Φ (°/R) [']	AM						
						182	184	213/215	254/256	284/286	324/326	364/365
K97  3	7.54	225	21200	3210	10							
	8.71	195	23500	3200	10							
	10.41	163	25300	3320	10							
	11.99	142	34400	3260	8							
	13.85	123	38100	3220	8							
	16.56	103	38100	3580	8							
	18.96	90	38100	3860	8							
	22.37	76	38100	4230	8							
	24.75	69	38100	4460	8							
	27.91	61	38100	4750	8							
	30.82	55	38100	5000	7							
	34.23	50	38100	5260	7							
	38.30	44	38100	5560	7							
	41.87	41	38100	5800	7							
	47.93	35	38100	6180	7							
	56.55	30	38100	6660	7							
	62.55	27	38100	6970	7							
	70.54	24	38100	7350	7							
	77.89	22	38100	7670	7							
	86.52	20	38100	8030	7							
96.80	18	38100	8420	7								
105.13	16	38100	8710	7								
123.93	14	38100	8990	7								
140.28	12	38100	8990	7								
153.21	11	38100	8990	7								
176.05	9.7	38100	8990	7								

Weight [lbs]		Stages	AM						
			182	184	213/215	254/256	284/286	324/326	364/365
K97	NEMA	3	350	350	365	395	400	440	440
			100	112	132S/M	160	180	200	225
	IEC	3	355	355	370	405	410	445	455

KA97: -40 lbs / KAF97: +15 lbs / KF97: +44 lbs

10.1.18 K97R57

K97R57, $n_e = 1700$ rpm							38100 lb-in					
i [ratio]	n_a [rpm]	T_a max [lb-in]	$F_{Ra}^{1)}$ [lb]	Stages		ϕ (/R) [']	AM					
				Lg	Sm		56	143	145	182	184	213/215
199	8.5	38100	8990	3	2	-						
232	7.3	38100	8990	3	2	-						
258	6.6	38100	8990	3	2	-						
305	5.6	38100	8990	3	2	-						
342	5.0	38100	8990	3	2	-						
382	4.5	38100	8990	3	2	-						
437	3.9	38100	8990	3	2	-						
504	3.4	38100	8990	3	2	-						
573	3.0	38100	8990	3	2	-						
652	2.6	38100	8990	3	2	-						
743	2.3	38100	8990	3	2	-						
855	2.0	38100	8990	3	2	-						
957	1.8	38100	8990	3	2	-						
1102	1.5	38100	8990	3	2	-						
1261	1.3	38100	8990	3	2	-						
1430	1.2	38100	8990	3	2	-						
1625	1.0	38100	8990	3	2	-						
1856	0.92	38100	8990	3	2	-						
2123	0.80	38100	8990	3	2	-						
2419	0.70	38100	8990	3	2	-						
2757	0.62	38100	8990	3	3	-						
3108	0.55	38100	8990	3	3	-						
3583	0.47	38100	8990	3	3	-						
4082	0.42	38100	8990	3	3	-						
4669	0.36	38100	8990	3	3	-						
5391	0.32	38100	8990	3	3	-						
6027	0.28	38100	8990	3	3	-						
6970	0.24	38100	8990	3	3	-						
8054	0.21	38100	8990	3	3	-						
9083	0.19	38100	8990	3	3	-						
10317	0.16	38100	8990	3	3	-						
11677	0.15	38100	8990	3	3	-						
13182	0.13	38100	8990	3	3	-						
14897	0.11	38100	8990	3	3	-						
16666	0.10	38100	8990	3	3	-						
18091	0.09	38100	8990	3	3	-						

Weight [lbs]		Stages		AM					
		Large	Small	56	143	145	182	184	213/215
K97R57	NEMA	3	2	390	395	395	405	405	415
		3	3	395	400	400	405	405	420
	IEC			71	80	90	100	112	132S/M
		3	2	390	395	395	405	405	420
		3	3	395	400	400	410	410	425

KA97: -40 lbs / KAF97: +15 lbs / KF97: +44 lbs

10.1.19 K107

K107, n _e = 1700 rpm						70800 lb-in						
Stages	i [ratio]	n _a [rpm]	T _{a max} [lb-in]	F _{Ra} [lb]	Φ (/R) [']	AM						
						182	184	213/215	254/256	284/286	324/326	364/365
K107  3	7.35	231	31800	5010	9							
	8.69	196	36000	5050	9							
	9.94	171	37000	5290	9							
	11.73	145	38000	5640	9							
	13.43	127	38000	6010	9							
	14.64	116	60900	3600	7							
	16.75	101	62300	3920	7							
	19.74	86	63700	4400	6							
	22.62	75	63700	4970	6							
	26.32	65	63700	5620	6							
	29.00	59	63700	6040	6							
	31.28	54	60100	6840	6							
	32.69	52	63700	6570	6							
	37.00	46	63700	7130	6							
	42.33	40	65100	7580	6							
	49.90	34	69300	7840	6							
	57.17	30	70800	8360	6							
	66.52	26	70800	9150	6							
	73.30	23	70800	9680	6							
	82.61	21	70800	10300	6							
90.96	19	70800	10900	6								
100.75	17	70800	11500	6								
112.41	15	70800	12100	6								
121.46	14	70800	12600	6								
143.47	12	70800	13600	6								

Weight [lbs]		Stages	AM						
			182	184	213/215	254/256	284/286	324/326	364/365
K107	NEMA	3	600	600	610	640	650	690	690
			100	112	132S/M	160	180	200	225
	IEC	3	610	610	610	660	660	690	700

KA107: -60 lbs / KAF107: +7 lbs / KF107: +27 lbs

10 K - Helical Bevel

K.. AM

10.1.20 K107R77

K107R57, $n_e = 1700$ rpm							70800 lb-in					
i [ratio]	n_a [rpm]	T_a max [lb-in]	$F_{Ra}^{1)}$ [lb]	Stages		ϕ (/R) [']	AM					
				Lg	Sm		56	143	145	182	184	213/215
140	12	63720	14610	3	2	-						
154	11	63720	14610	3	2	-						
174	9.8	63720	14610	3	2	-						
196	8.7	70800	14610	3	2	-						
222	7.7	70800	14610	3	2	-						
251	6.8	70800	14610	3	2	-						
286	5.9	70800	14610	3	2	-						
318	5.3	70800	14610	3	2	-						
364	4.7	70800	14610	3	2	-						
408	4.2	70800	14610	3	2	-						
461	3.7	70800	14610	3	2	-						
522	3.3	70800	14610	3	2	-						
615	2.8	70800	14610	3	2	-						
696	2.4	70800	14610	3	2	-						
793	2.1	70800	14610	3	2	-						
904	1.9	70800	14610	3	2	-						
1030	1.7	70800	14610	3	2	-						
1166	1.5	70800	14610	3	2	-						
1336	1.3	70800	14610	3	2	-						
1554	1.1	70800	14610	3	2	-						
1713	0.99	70800	14610	3	2	-						
1939	0.88	70800	14610	3	3	-						
2286	0.74	70800	14610	3	3	-						
2599	0.65	70800	14610	3	3	-						
2977	0.57	70800	14610	3	3	-						
3358	0.51	70800	14610	3	3	-						
3810	0.45	70800	14610	3	3	-						
4359	0.39	70800	14610	3	3	-						
5138	0.33	70800	14610	3	3	-						
5662	0.30	70800	14610	3	3	-						
6184	0.27	70800	14610	3	3	-						
7270	0.23	70800	14610	3	3	-						
8328	0.20	70800	14610	3	3	-						
9524	0.18	70800	14610	3	3	-						
10677	0.16	70800	14610	3	3	-						
12211	0.14	70800	14610	3	3	-						
14311	0.12	70800	14610	3	3	-						

Weight [lbs]		Stages		AM					
		Large	Small	56	143	145	182	184	213/215
K107R77	NEMA	3	2	680	680	680	690	690	700
		3	3	680	680	680	690	690	700
	IEC			71	80	90	100	112	132S/M
		3	2	670	680	680	690	690	700
		3	3	680	680	680	690	690	710

KA107: -60 lbs / KAF107: +7 lbs / KF107: +27 lbs

10.1.21 K127

K127, $n_e = 1700$ rpm						115000 lb-in				
Stages	i [ratio]	n_a [rpm]	$T_{a \max}$ [lb-in]	F_{Ra} [lb]	Φ (R) [']	AM				
						213/215	254/256	284/286	324/326	364/365
K127  3	8.68	196	63900	6630	8					
	10.74	158	70700	6880	8					
	12.79	133	75400	7190	8					
	14.35	118	107000	5880	6					
	17.77	96	115000	6160	6					
	21.15	80	115000	7200	6					
	23.91	71	115000	7940	6					
	27.68	61	115000	8710	6					
	31.37	54	115000	9320	6					
	36.25	47	115000	10100	6					
	40.19	42	115000	10600	5					
	47.82	36	115000	11600	5					
	54.07	31	115000	12300	5					
	62.60	27	115000	13200	5					
	70.95	24	115000	13900	5					
	81.98	21	115000	14900	5					
	89.89	19	115000	15500	5					
	110.18	15	115000	16900	5					
122.48	14	115000	17700	5						
136.14	12	115000	17800	5						
146.07	12	115000	17800	5						

Weight [lbs]	Stages	AM					
		213/215	254/256	284/286	324/326	364/365	
K127	NEMA	3	970	990	990	1030	1030
			132S/M	160	180	200	225
	IEC	3	970	1000	1000	1030	1040

KA127: -62 lbs / KAF127: +20 lbs / KF127: +93 lbs

10.1.22 K127R77

K127R77, $n_e = 1700$ rpm							115000 lb-in					
i [ratio]	n_a [rpm]	$T_{a \max}$ [lb-in]	$F_{Ra}^{1)}$ [lb]	Stages		ϕ (/R) [']	AM					
				Lg	Sm		56	143	145	182	184	213/215
418	4.1	115000	17800	3	2	-						
477	3.6	115000	17800	3	2	-						
549	3.1	115000	17800	3	2	-						
610	2.8	115000	17800	3	2	-						
704	2.4	115000	17800	3	2	-						
790	2.2	115000	17800	3	2	-						
899	1.9	115000	17800	3	2	-						
1025	1.7	115000	17800	3	2	-						
1177	1.4	115000	17800	3	2	-						
1342	1.3	115000	17800	3	2	-						
1541	1.1	115000	17800	3	2	-						
1757	0.97	115000	17800	3	2	-						
1926	0.88	115000	17800	3	2	-						
2268	0.75	115000	17800	3	3	-						
2607	0.65	115000	17800	3	3	-						
3009	0.56	115000	17800	3	3	-						
3311	0.51	115000	17800	3	3	-						
3889	0.44	115000	17800	3	3	-						
4423	0.38	115000	17800	3	3	-						
5027	0.34	115000	17800	3	3	-						
5804	0.29	115000	17800	3	3	-						
6565	0.26	115000	17800	3	3	-						
7482	0.23	115000	17800	3	3	-						
8443	0.20	115000	17800	3	3	-						
9819	0.17	115000	17800	3	3	-						
10915	0.16	115000	17800	3	3	-						
12440	0.14	115000	17800	3	3	-						
14975	0.11	115000	17800	3	3	-						
16006	0.11	115000	17800	3	3	-						
17550	0.10	115000	17800	3	3	-						

Weight [lbs]		Stages		AM					
		Large	Small	56	143	145	182	184	213/215
K127R77	NEMA	3	2	1030	1030	1030	1040	1040	1050
		3	3	1030	1040	1040	1040	1040	1060
			71	80	90	100	112	132S/M	
	IEC	3	2	1030	1030	1030	1040	1040	1060
		3	3	1030	1040	1040	1050	1050	1060

KA127: -62 lbs / KAF127: +20 lbs / KF127: +93 lbs

10.1.23 K127R87

K127R87, $n_e = 1700$ rpm							115000 lb-in						
i [ratio]	n_a [rpm]	T_a max [lb-in]	$F_{Ra}^{1)}$ [lb]	Stages		ϕ (/R) [']	AM						
				Lg	Sm		143	145	182	184	213/215	254/256	284/286
147	12	106200	17920	3	2	-							
166	10	106200	17920	3	2	-							
200	8.5	106200	17920	3	2	-							
213	8.0	115000	17800	3	2	-							
253	6.7	115000	17800	3	2	-							
287	5.9	115000	17800	3	2	-							
330	5.2	115000	17800	3	2	-							
367	4.6	115000	17800	3	2	-							
418	4.1	115000	17800	3	2	-							
473	3.6	115000	17800	3	2	-							
536	3.2	115000	17800	3	2	-							

Weight [lbs]	Stages		AM							
	Large	Small	143	145	182	184	213/215	254/256	284/286	
K127R87	NEMA	3	2	1080	1080	1090	1090	1100	1130	1140
				80	90	100	112	132S/M	160	180
	IEC	3	2	1080	1080	1090	1090	1110	1140	1140

KA127: -62 lbs / KAF127: +20 lbs / KF127: +93 lbs

10 K - Helical Bevel

K.. AM

10.1.24 K157

K157, $n_e = 1700$ rpm						159300 lb-in			
Stages	i [ratio]	n_a [rpm]	$T_{a \max}$ [lb-in]	F_{Ra} [lb]	ϕ (/R) [']	AM			
						254/256	284/286	324/326	364/365
K157  3	12.65	134	150400	7300	6				
	14.92	114	159300	7600	6				
	18.37	93	159300	8660	6				
	21.31	80	159300	9450	6				
	23.95	71	159300	10100	6				
	27.62	62	159300	10900	6				
	31.30	54	159300	11700	6				
	38.02	45	159300	12900	5				
	46.79	36	159300	14300	5				
	54.29	31	159300	15400	5				
	61.02	28	159300	16300	5				
	70.38	24	159300	17400	5				
	79.75	21	159300	18300	5				
	91.65	19	159300	19500	5				
	100.22	17	159300	20300	5				
122.39	14	159300	22100	5					
150.41	11	159300	24100	5					

Weight [lbs]		Stages	AM			
			254/256	284/286	324/326	364/365
K157	NEMA	3	1510	1510	1560	1560
			160	180	200	225
	IEC	3	1520	1520	1560	1570

KA157: -81 lbs / KAF157: +48 lbs / KF157: +173 lbs

10.1.25 K157R97

K157R97, n _e = 1700 rpm							159300 lb-in						
i [ratio]	n _a [rpm]	T _a max [lb-in]	F _{Ra} ¹⁾ [lb]	Stages		φ (i/R) [']	AM						
				Lg	Sm		182	184	213/215	254/256	284/286	324/326	364/365
291	5.8	159300	25220	3	2	-							
333	5.1	159300	25220	3	2	-							
379	4.5	159300	25220	3	2	-							
434	3.9	159300	25220	3	2	-							
504	3.4	159300	25220	3	2	-							
567	3.0	159300	25220	3	2	-							
661	2.6	159300	25220	3	2	-							
756	2.2	159300	25220	3	2	-							
854	2.0	159300	25220	3	2	-							
942	1.8	159300	25220	3	2	-							
1093	1.6	159300	25220	3	2	-							
1229	1.4	159300	25220	3	2	-							
1365	1.2	159300	25220	3	2	-							
1659	1.0	159300	25220	3	2	-							
1805	0.94	159300	25220	3	3	-							
2029	0.84	159300	25220	3	3	-							
2322	0.73	159300	25220	3	3	-							
2610	0.65	159300	25220	3	3	-							
3051	0.56	159300	25220	3	3	-							
3516	0.48	159300	25220	3	3	-							
3979	0.43	159300	25220	3	3	-							
4514	0.38	159300	25220	3	3	-							
5074	0.34	159300	25220	3	3	-							
5931	0.29	159300	25220	3	3	-							
6881	0.25	159300	25220	3	3	-							
7734	0.22	159300	25220	3	3	-							
8718	0.19	159300	25220	3	3	-							
10114	0.17	159300	25220	3	3	-							
11368	0.15	159300	25220	3	3	-							

Weight [lbs]	NEMA	Stages		AM						
		Large	Small	182	184	213/215	254/256	284/286	324/326	364/365
K157R97	NEMA	3	2	1740	1740	1750	1780	1790	1820	1820
		3	3	1740	1740	1760	1790	1790	1830	1830
	IEC	3	2	1740	1740	1750	1790	1790	1830	1840
		3	3	1750	1750	1760	1800	1800	1840	1850

KA157: -81 lbs / KAF157: +48 lbs / KF157: +173 lbs

10.1.26 K157R107

K157R107, $n_e = 1700$ rpm							159300 lb-in				
i [ratio]	n_a [rpm]	T_a max [lb-in]	$F_{Ra}^{1)}$ [lb]	Stages		ϕ (/R) [']	AM				
				Lg	Sm		213/215	254/256	284/286	324/326	364/365
107	16	159300	22000	3	2	-					
122	14	159300	23270	3	2	-					
157	11	159300	25220	3	2	-					
187	9.1	159300	25220	3	2	-					
213	8.0	159300	25220	3	2	-					
230	7.4	159300	25220	3	2	-					
253	6.7	159300	25220	3	2	-					
299	5.7	159300	25220	3	2	-					
325	5.2	159300	25220	3	2	-					
385	4.4	159300	25220	3	2	-					

Weight [lbs]	Stages		AM					
	Large	Small	213/215	254/256	284/286	324/326	364/365	
K157R107	NEMA	3	2	1850	1880	1890	1920	1920
				132S/M	160	180	200	225
	IEC	3	2	1850	1890	1890	1930	1940

KA157: -81 lbs / KAF157: +48 lbs / KF157: +173 lbs

10.1.27 K167

K167, n _e = 1700 rpm						283200 lb-in			
Stages	i [ratio]	n _a [rpm]	T _{a max} [lb-in]	F _{Ra} [lb]	Φ (/R) [']	AM			
						254/256	284/286	324/326	364/365
 K167 3	17.34	98	283200	13600	5				
	20.32	84	283200	14900	5				
	24.52	69	283200	16600	5				
	28.77	59	283200	18000	5				
	32.25	53	283200	19100	5				
	36.61	46	283200	20400	5				
	42.89	40	283200	22000	5				
	51.77	33	283200	24100	5				
	60.74	28	283200	25900	5				
	68.07	25	283200	27200	5				
	78.14	22	283200	28900	5				
	87.86	19	283200	30500	5				
	109.83	15	283200	33500	5				
	134.99	13	283200	33700	4				
164.50	10	283200	33700	4					

Weight [lbs]		Stages	AM			
			254/256	284/286	324/326	364/365
K167	NEMA	3	2380	2380	2430	2430
			160	180	200	225
	IEC	3	2390	2390	2430	2440

KH167: -84 lbs

10.1.28 K167R97

K167R97, $n_e = 1700$ rpm							283200 lb-in						
i [ratio]	n_a [rpm]	T_a max [lb-in]	$F_{Ra}^{1)}$ [lb]	Stages		ϕ (/R) [']	AM						
				Lg	Sm		182	184	213/215	254/256	284/286	324/326	364/365
369	4.6	283200	33720	3	2	-							
423	4.0	283200	33720	3	2	-							
481	3.5	283200	33720	3	2	-							
561	3.0	283200	33720	3	2	-							
632	2.7	283200	33720	3	2	-							
757	2.2	283200	33720	3	2	-							
843	2.0	283200	33720	3	2	-							
944	1.8	283200	33720	3	2	-							
1101	1.5	283200	33720	3	2	-							
1296	1.3	283200	33720	3	2	-							
1408	1.2	283200	33720	3	2	-							
1704	1.0	283200	33720	3	2	-							
2182	0.78	283200	33720	3	2	-							
2263	0.75	283200	33720	3	3	-							
2755	0.62	283200	33720	3	3	-							
3376	0.50	283200	33720	3	3	-							
4079	0.42	283200	33720	3	3	-							
4788	0.36	283200	33720	3	3	-							
5355	0.32	283200	33720	3	3	-							
6562	0.26	283200	33720	3	3	-							
8628	0.20	283200	33720	3	3	-							
10264	0.17	283200	33720	3	3	-							
11573	0.15	283200	33720	3	3	-							

Weight [lbs]		Stages		AM						
		Large	Small	182	184	213/215	254/256	284/286	324/326	364/365
K167R97	NEMA	3	2	2610	2610	2620	2650	2650	2690	2690
		3	3	2610	2610	2620	2660	2660	2700	2700
			100	112	132S/M	160	180	200	225	
	IEC	3	2	2610	2610	2620	2660	2660	2700	2710
3		3	2610	2610	2630	2670	2670	2700	2710	

KH167: -84 lbs

10.1.29 K167R107

K167R107, n _e = 1700 rpm							283200 lb-in				
i [ratio]	n _a [rpm]	T _{a max} [lb-in]	F _{Ra} ¹⁾ [lb]	Stages		φ (/R) [']	AM				
				Lg	Sm		213/215	254/256	284/286	324/326	364/365
369	4.6	283200	33720	3	2	-					
423	4.0	283200	33720	3	2	-					
481	3.5	283200	33720	3	2	-					
561	3.0	283200	33720	3	2	-					
632	2.7	283200	33720	3	2	-					
757	2.2	283200	33720	3	2	-					
843	2.0	283200	33720	3	2	-					
944	1.8	283200	33720	3	2	-					
1101	1.5	283200	33720	3	2	-					
1296	1.3	283200	33720	3	2	-					
1408	1.2	283200	33720	3	2	-					
1704	1.0	283200	33720	3	2	-					
2182	0.78	283200	33720	3	2	-					
2263	0.75	283200	33720	3	3	-					
2755	0.62	283200	33720	3	3	-					
3376	0.50	283200	33720	3	3	-					
4079	0.42	283200	33720	3	3	-					
4788	0.36	283200	33720	3	3	-					
5355	0.32	283200	33720	3	3	-					
6562	0.26	283200	33720	3	3	-					
8628	0.20	283200	33720	3	3	-					
10264	0.17	283200	33720	3	3	-					
11573	0.15	283200	33720	3	3	-					

10

Weight [lbs]		Stages		AM				
		Large	Small	213/215	254/256	284/286	324/326	364/365
K167R107	NEMA	3	2	2710	2750	2760	2790	2790
		3	3	2710	2760	2770	2800	2800
			132S/M	160	180	200	225	
	IEC	3	2	2720	2760	2760	2800	2810
		3	3	2730	2770	2770	2810	2820
	KH167: -84 lbs							

10 K - Helical Bevel

K.. AM

10.1.30 K187

K187, $n_e = 1700$ rpm						442500 lb-in			
Stages	i [ratio]	n_a [rpm]	$T_{a \max}$ [lb-in]	F_{Ra} [lb]	ϕ (/R) [']	AM			
						254/256	284/286	324/326	364/365
K187  3	17.18	99	366300	16300	4				
	20.15	84	388400	16900	4				
	24.18	70	421100	17500	4				
	27.92	61	442500	18100	4				
	33.23	51	442500	20000	4				
	38.57	44	442500	21800	4				
	42.51	40	442500	22900	4				
	45.50	37	442500	23700	4				
	53.36	32	442500	25800	4				
	64.04	27	442500	28200	4				
	73.96	23	442500	30200	4				
	88.00	19	442500	32700	4				
	102.16	17	442500	35000	4				
	112.60	15	442500	36600	4				
	129.69	13	442500	38900	4				
	144.59	12	442500	40800	4				
165.21	10	442500	42700	4					
179.86	9.5	442500	42700	4					

Weight [lbs]		Stages	AM			
			254/256	284/286	324/326	364/365
K187	NEMA	3	3660	3670	3710	3710
			160	180	200	225
	IEC	3	3670	3670	3720	3730

KH187: -150 lbs

10.1.31 K187R97

K187R97, n _e = 1700 rpm							442500 lb-in						
i [ratio]	n _a [rpm]	T _a max [lb-in]	F _{Ra} ¹⁾ [lb]	Stages		φ (°/R) [']	AM						
				Lg	Sm		182	184	213/215	254/256	284/286	324/326	364/365
527	3.2	442500	42710	3	2	-							
621	2.7	442500	42710	3	2	-							
738	2.3	442500	42710	3	2	-							
945	1.8	442500	42710	3	2	-							
1046	1.6	442500	42710	3	2	-							
1196	1.4	442500	42710	3	2	-							
1395	1.2	442500	42710	3	2	-							
1605	1.1	442500	42710	3	2	-							
1821	0.93	442500	42710	3	2	-							
2054	0.83	442500	42710	3	2	-							
2268	0.75	442500	42710	3	2	-							
2519	0.67	442500	42710	3	2	-							
2818	0.60	442500	42710	3	3	-							
3062	0.56	442500	42710	3	2	-							
3609	0.47	442500	42710	3	2	-							
4370	0.39	442500	42710	3	3	-							
4817	0.35	442500	42710	3	3	-							
5358	0.32	442500	42710	3	3	-							
5991	0.28	442500	42710	3	3	-							
6747	0.25	442500	42710	3	3	-							
7343	0.23	442500	42710	3	3	-							
8126	0.21	442500	42710	3	3	-							
9363	0.18	442500	42710	3	3	-							
10413	0.16	442500	42710	3	3	-							
11647	0.15	442500	42710	3	3	-							
13116	0.13	442500	42710	3	3	-							
14272	0.12	442500	42710	3	3	-							
16978	0.10	442500	42710	3	3	-							
19144	0.09	442500	42710	3	3	-							
24353	0.07	442500	42710	3	3	-							

Weight [lbs]		Stages		AM						
		Large	Small	182	184	213/215	254/256	284/286	324/326	364/365
K187R97	NEMA	3	2	3890	3890	3900	3930	3940	3980	3980
		3	3	3900	3900	3910	3940	3940	3980	3980
	IEC			100	112	132S/M	160	180	200	225
		3	2	3890	3890	3900	3940	3940	3980	3990
		3	3	3900	3900	3910	3950	3950	3990	4000

KH187: -150 lbs

10.1.32 K187R107

K187R107, n _e = 1700 rpm											442500 lb-in			
i [ratio]	n _a [rpm]	T _{a max} [lb-in]	F _{Ra} ¹⁾ [lb]	Stages		Φ (/R) [']	AM							
				Lg	Sm		182	184	213/215	254/256	284/286	324/326	364/365	
163	10	442500	42710	3	2	-								
193	8.8	442500	42710	3	2	-								
221	7.7	442500	42710	3	2	-								
261	6.5	442500	42710	3	2	-								
355	4.8	442500	42710	3'	2	-								
454	3.7	442500	42710	3	2	-								
520	3.3	442500	42710	3	2	-								
622	2.7	442500	42710	3	2	-								
729	2.3	442500	42710	3	2	-								
835	2.0	442500	42710	3	2	-								

Weight [lbs]		Stages		AM						
		Large	Small	182	184	213/215	254/256	284/286	324/326	364/365
K187R107	NEMA	3	2	3990	3990	4000	4030	4040	4080	4080
				100	112	132S/M	160	180	200	225
	IEC	3	2	4000	4000	4000	4040	4050	4080	4090

KH187: -150 lbs

10.2 K.. AD

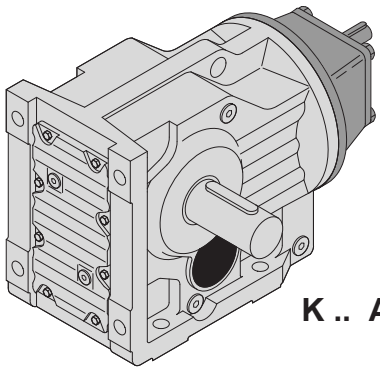

K .. AD..

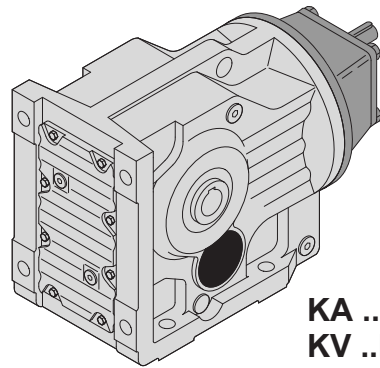

KA ..B AD..
KV ..B AD..

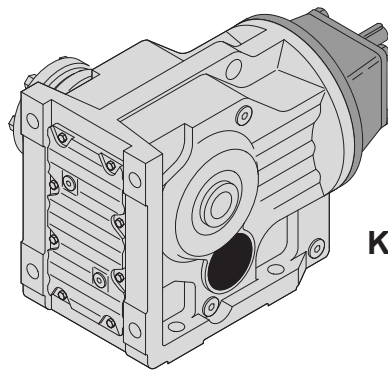

KH ..B AD..

10

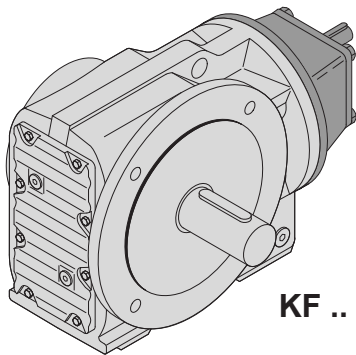

KF .. AD..

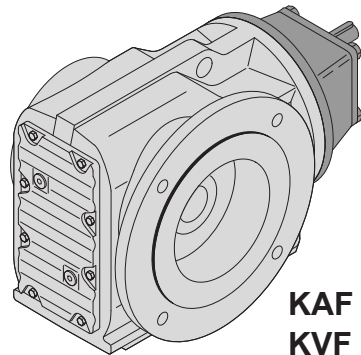

KAF .. AD..
KVF .. AD..

50409AXX

10 K - Helical Bevel

K.. AD

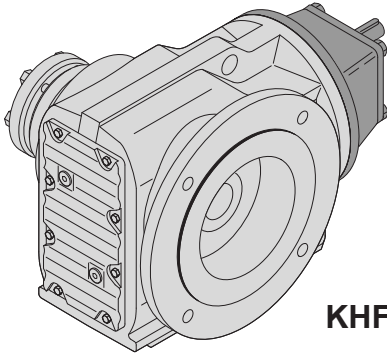

KHF .. AD..

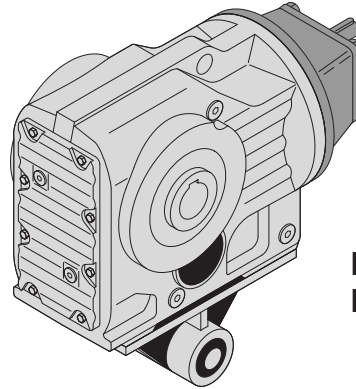

**KA../T AD..
KV../T AD..**

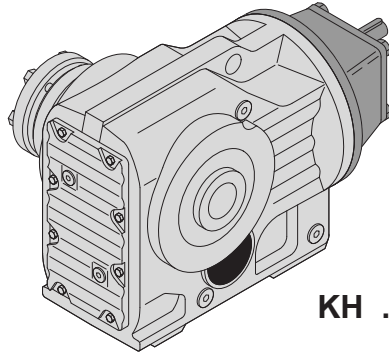

KH .. AD..

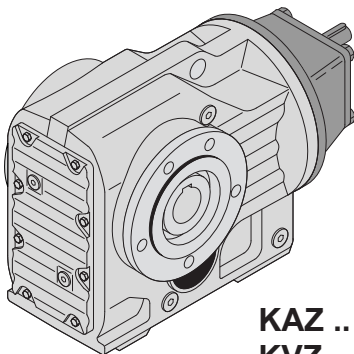

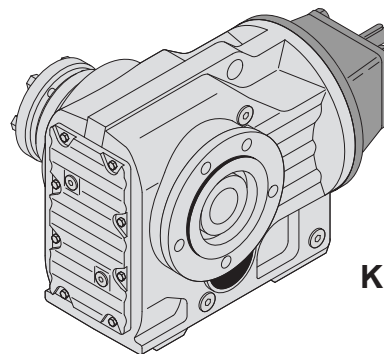

**KAZ .. AD..
KVZ .. AD..**



KHZ .. AD..

50410AXX

10.2.1 K19

K19 AD.. , n _e = 1700 rpm										710 lb-in	
i [ratio]	n _a [rpm]	T _a max [lb-in]	P _e [HP]	F _{Ra} ¹⁾ [lb]	F _{Re} [lb]	Stages		φ (/R) [']			
						Lg	Sm				
12.70	134	710	1.6	610	0	2	-	-	-		
14.69	116	710	1.3	640	10	2	-	-	-		
15.84	107	710	1.2	670	20	2	-	-	-		
18.55	92	710	1.1	710	20	2	-	-	-		
21.98	77	710	0.90	760	30	2	-	-	-		
24.06	71	710	0.82	790	40	2	-	-	-		K19 AD1
27.16	63	530	0.54	850	120	2	-	-	-		
29.29	58	540	0.51	870	120	2	-	-	-		
34.29	50	570	0.46	920	120	2	-	-	-		
40.63	42	590	0.40	980	120	2	-	-	-		
44.48	38	610	0.38	970	120	2	-	-	-		
4.50	378	650	4.0	430	250	2	-	-	M1-6		
5.16	329	710	3.8	440	240	2	-	-	M1-6		
5.54	307	710	3.6	460	250	2	-	-	M1-6		
6.41	265	710	3.1	490	260	2	-	-	-		
6.91	246	710	2.9	500	260	2	-	-	-		
8.09	210	710	2.4	540	270	2	-	-	-		
9.58	177	560	1.6	610	100	2	-	-	-		
10.32	165	670	1.8	560	330	2	-	-	-		
11.84	144	700	1.6	590	330	2	-	-	-		
12.70	134	710	1.6	610	330	2	-	-	-		
14.69	116	710	1.3	640	340	2	-	-	-		K19 AD2
15.84	107	710	1.2	670	340	2	-	-	-		
18.55	92	710	1.1	710	340	2	-	-	-		
21.98	77	710	0.90	760	270	2	-	-	-		
24.06	71	710	0.82	790	280	2	-	-	-		
27.16	63	530	0.54	850	370	2	-	-	-		
29.29	58	540	0.51	870	370	2	-	-	-		
34.29	50	570	0.46	920	370	2	-	-	-		
40.63	42	590	0.40	980	370	2	-	-	-		
44.48	38	610	0.38	970	370	2	-	-	-		



Weight [lbs]	Stages		AD1	AD2
	Large	Small		
K19	3	-	13	16

KA19: -0.5 lbs / KAF19: +0 lbs / KF19: +1.0 lbs

10 K - Helical Bevel

K.. AD



10.2.2 K29

K29 AD.. , $n_e = 1700$ rpm										1150 lb-in			
i [ratio]	n_a [rpm]	$T_{a \max}$ [lb-in]	P_e [HP]	$F_{Ra}^{(1)}$ [lb]	F_{Re} [lb]	Stages		ϕ (°/R) [']					
						Lg	Sm			K29	AD1		
16.29	104	920	1.6	720	0	2	-	-	-	K29	AD1		
19.99	85	1030	1.4	760	0	2	-	-	-				
22.08	77	930	1.2	790	70	2	-	-	-				
23.19	73	1060	1.3	800	0	2	-	-	-				
24.91	68	960	1.1	820	70	2	-	-	-				
27.23	62	1110	1.1	850	0	2	-	-	-				
29.69	57	1130	1.1	880	0	2	-	-	-				
30.11	56	1020	0.94	880	70	2	-	-	-				
36.96	46	1080	0.81	940	80	2	-	-	-				
42.87	40	1130	0.73	990	80	2	-	-	-				
50.35	34	1150	0.63	1060	80	2	-	-	-				
54.89	31	1150	0.58	1100	80	2	-	-	-				
3.19	533	970	8.5	380	160	2	-	-	M1-6			K29	AD2
3.92	434	1120	7.9	390	150	2	-	-	M1-6				
5.10	333	970	5.3	470	210	2	-	-	M1-6				
5.75	296	990	4.8	490	220	2	-	-	-				
6.95	245	970	3.9	540	230	2	-	-	-				
7.48	227	1090	4.1	470	280	2	-	-	M1-6				
8.53	199	1000	3.3	580	240	2	-	-	-				
9.17	185	1150	3.5	500	290	2	-	-	M1-6				
9.90	172	970	2.7	620	250	2	-	-	-				
11.94	142	1150	2.7	570	300	2	-	-	-				
13.47	126	1150	2.4	610	310	2	-	-	-				
16.29	104	1150	2.0	670	310	2	-	-	-				
19.99	85	1150	1.6	730	320	2	-	-	-				
22.08	77	930	1.2	790	360	2	-	-	-				
23.19	73	1150	1.4	780	320	2	-	-	-				
24.91	68	960	1.1	820	360	2	-	-	-				
27.23	62	1150	1.2	840	200	2	-	-	-				
29.69	57	1150	1.1	870	210	2	-	-	-				
30.11	56	1020	0.94	880	360	2	-	-	-				
36.96	46	1080	0.81	940	360	2	-	-	-				
42.87	40	1130	0.73	990	360	2	-	-	-				
50.35	34	1150	0.63	1060	330	2	-	-	-				
54.89	31	1150	0.58	1100	340	2	-	-	-				

Weight [lbs]	Stages		AD1	AD2
	Large	Small		
K29	3	-	16	19

KA29: -0 lbs / KAF29: +2 lbs / KF29: +2.5 lbs



10.2.3 K37

K37 AD.. , n _e = 1700 rpm										1770 lb-in			
i [ratio]	n _a [rpm]	T _{a max} [lb-in]	P _e [HP]	F _{Ra} ¹⁾ [lb]	F _{Re} [lb]	Stages		φ (°/R) [']					
						Lg	Sm						
29.96	57	1680	1.6	760	80	3	-	7	-	K37	AD1		
35.57	48	1770	1.4	810	80	3	-	7	-				
37.97	45	1770	1.3	840	90	3	-	7	-				
44.46	38	1770	1.1	910	90	3	-	7	-				
49.79	34	1770	1.0	960	100	3	-	7	-				
58.60	29	1770	0.85	1030	100	3	-	7	-				
67.80	25	1770	0.74	1100	110	3	-	7	-				
72.54	23	1770	0.69	1140	110	3	-	7	-				
83.69	20	1770	0.60	1210	110	3	-	7	-				
97.81	17	1770	0.51	1270	120	3	-	7	-				
106.38	16	1770	0.47	1270	120	3	-	7	-				
3.98	427	1110	7.9	330	220	3	-	13	M1-6	K37	AD2		
5.36	317	1240	6.5	360	230	3	-	13	M1-6				
6.37	267	1280	5.7	390	240	3	-	13	-				
6.80	250	1330	5.5	400	240	3	-	13	-				
7.96	214	1370	4.9	430	240	3	-	13	-				
8.91	191	1420	4.5	440	250	3	-	12	-				
10.49	162	1420	3.8	490	250	3	-	12	-				
12.14	140	1420	3.3	530	260	3	-	12	-				
13.08	130	1460	3.2	540	310	3	-	9	-				
15.31	111	1550	2.9	560	310	3	-	9	-				
17.15	99	1590	2.6	590	310	3	-	8	-				
20.19	84	1640	2.3	630	310	3	-	8	-				
23.36	73	1730	2.1	660	310	3	-	8	-				
24.99	68	1770	2.0	680	310	3	-	8	-				
28.83	59	1770	1.7	730	320	3	-	8	-				
29.96	57	1770	1.7	740	360	3	-	7	-				
35.57	48	1770	1.4	810	340	3	-	7	-				
37.97	45	1770	1.3	840	340	3	-	7	-				
44.46	38	1770	1.1	910	350	3	-	7	-				
49.79	34	1770	1.0	960	360	3	-	7	-				
58.60	29	1770	0.85	1030	360	3	-	7	-				
67.80	25	1770	0.74	1100	370	3	-	7	-				
72.54	23	1770	0.69	1140	370	3	-	7	-				
83.69	20	1770	0.60	1210	370	3	-	7	-				
97.81	17	1770	0.51	1270	370	3	-	7	-				
106.38	16	1770	0.47	1270	370	3	-	7	-				
Weight [lbs]		Stages		AD1		AD2							
		Large	Small										
K37		3	-	30		33							
KA37: -0.5 lbs / KAF37: +3 lbs / KF37: +5 lbs													



10 K - Helical Bevel

K.. AD



10.2.4 K39

K39 AD.. , $n_e = 1700$ rpm										2660 lb-in	
i [ratio]	n_a [rpm]	$T_{a \max}$ [lb-in]	P_e [HP]	$F_{Ra}^{(1)}$ [lb]	F_{Re} [lb]	Stages		ϕ (°/R) [']			
						Lg	Sm			K39	AD2
2.81	605	1130	11.5	650	180	2	-	-			
3.94	431	1510	10.9	690	160	2	-	-			
4.52	376	1690	10.6	700	140	2	-	-			
5.22	326	1860	10.1	730	120	2	-	-			
5.75	296	1990	9.8	740	110	2	-	-			
6.75	252	2260	9.5	760	80	2	-	-			
7.15	238	2350	9.3	760	70	2	-	-			
8.12	209	2520	8.8	790	40	2	-	-			
9.00	189	2660	8.4	810	20	2	-	-			
9.60	177	2210	6.9	740	270	2	-	-			
10.61	160	2520	6.7	890	80	2	-	-			
12.09	141	1650	3.9	1080	230	2	-	-			
12.73	134	1700	3.8	1090	220	2	-	-			
13.44	126	2390	5.3	840	280	2	-	-		K39	AD2
15.44	110	2480	4.8	890	290	2	-	-			
17.83	95	2570	4.3	940	290	2	-	-			
19.62	87	2610	4.0	980	290	2	-	-			
23.04	74	2660	3.5	1050	300	2	-	-			
24.40	70	2660	3.3	1090	300	2	-	-			
27.73	61	2660	2.9	1160	300	2	-	-			
30.72	55	2660	2.6	1220	310	2	-	-			
36.22	47	2660	2.2	1320	310	2	-	-			
41.28	41	2660	1.9	1410	320	2	-	-			
43.45	39	2660	1.8	1440	320	2	-	-			
49.69	34	2660	1.6	1530	320	2	-	-			
58.24	29	2660	1.4	1650	180	2	-	-			
2.81	605	1130	11.5	650	400	2	-	-			
3.94	431	1510	10.9	690	380	2	-	-			
4.52	376	1690	10.6	700	370	2	-	-			
5.22	326	1860	10.1	730	360	2	-	-			
5.75	296	1990	9.8	740	350	2	-	-			
6.75	252	2260	9.5	760	340	2	-	-			
7.15	238	2350	9.3	760	330	2	-	-			
8.12	209	2520	8.8	790	320	2	-	-			
9.00	189	2660	8.4	810	310	2	-	-			
9.60	177	2210	6.9	740	490	2	-	-			
10.61	160	2480	6.7	900	350	2	-	-			
13.44	126	2390	5.4	840	500	2	-	-			
15.44	110	2480	4.8	890	500	2	-	-			
17.83	95	2570	4.3	940	510	2	-	-			
19.62	87	2610	4.0	980	510	2	-	-			
23.04	74	2660	3.5	1050	510	2	-	-			
24.40	70	2660	3.3	1090	520	2	-	-			
27.73	61	2660	2.9	1160	520	2	-	-			
30.72	55	2660	2.6	1220	520	2	-	-			
36.22	47	2660	2.2	1320	530	2	-	-			
Weight [lbs]	Stages		AD2		AD3						
	Large	Small									
K39	3	-	45		52						
KA39: -2 lbs / KAF39: +1 lbs / KF39: +3 lbs											

10.2.5 K47

K47 AD.. , n _e = 1700 rpm										3540 lb-in		
i [ratio]	n _a [rpm]	T _a max [lb-in]	P _e [HP]	F _{Ra} ¹⁾ [lb]	F _{Re} [lb]	Stages		φ (/R) [']				
						Lg	Sm					
4.64	366	1500	9.1	670	210	3	-	12	M1-6			
5.81	293	1860	9.0	670	200	3	-	12	M1-6			
6.58	258	1990	8.5	690	200	3	-	12	M1-6			
7.36	231	2170	8.3	690	190	3	-	11	M1-6			
8.56	199	2350	7.7	720	190	3	-	11	-			
9.10	187	2480	7.7	710	180	3	-	11	-			
10.56	161	2480	6.6	780	190	3	-	11	-			
11.77	144	2480	5.9	820	200	3	-	10	-			
12.19	139	3100	7.2	750	230	3	-	8	-			
13.65	125	3190	6.6	780	240	3	-	8	-			
15.86	107	3360	6.0	820	240	3	-	8	-			
16.86	101	3360	5.6	850	240	3	-	8	-			
19.58	87	3540	5.1	890	240	3	-	8	-			
21.81	78	3540	4.6	950	250	3	-	8	-			
24.06	71	3540	4.2	1000	250	3	-	8	-			
25.91	66	3540	3.9	1050	260	3	-	8	-		K47	AD2
29.32	58	3540	3.4	1120	260	3	-	8	-			
31.30	54	3540	3.2	1160	260	3	-	7	-			
35.39	48	3540	2.8	1240	330	3	-	7	-			
39.61	43	3540	2.5	1310	340	3	-	7	-			
46.03	37	3540	2.2	1330	340	3	-	7	-			
48.95	35	3540	2.0	1330	340	3	-	7	-			
56.83	30	3540	1.8	1330	350	3	-	7	-			
63.30	27	3540	1.6	1330	280	3	-	7	-			
69.84	24	3540	1.4	1330	280	3	-	6	-			
75.20	23	3540	1.3	1330	290	3	-	6	-			
85.12	20	3540	1.2	1330	300	3	-	6	-			
90.86	19	3540	1.1	1330	300	3	-	6	-			
104.37	16	3540	0.96	1330	300	3	-	6	-			
121.48	14	3540	0.82	1330	310	3	-	6	-			
131.87	13	3540	0.76	1330	310	3	-	6	-			
4.64	366	1810	11.0	600	390	3	-	12	M1-6			
5.81	293	2040	9.9	630	400	3	-	12	M1-6			
6.58	258	2120	9.1	660	400	3	-	12	M1-6			
7.36	231	2210	8.5	680	400	3	-	11	M1-6			
8.56	199	2390	7.9	710	400	3	-	11	M2,4,6			
9.10	187	2480	7.7	710	400	3	-	11	-			
10.56	161	2480	6.6	780	410	3	-	11	-			
11.77	144	2480	5.9	820	420	3	-	10	-			
12.19	139	3100	7.2	750	450	3	-	8	M2,4,6			
13.65	125	3190	6.6	780	450	3	-	8	-			
15.86	107	3360	6.0	820	450	3	-	8	-			
16.86	101	3360	5.6	850	450	3	-	8	-			
19.58	87	3540	5.1	890	450	3	-	8	-			
21.81	78	3540	4.6	950	460	3	-	8	-			
25.91	66	3540	3.9	1050	470	3	-	8	-			
35.39	48	3540	2.8	1240	550	3	-	7	-			
39.61	43	3540	2.5	1310	550	3	-	7	-			
46.03	37	3540	2.2	1330	550	3	-	7	-			
48.95	35	3540	2.0	1330	550	3	-	7	-			
56.83	30	3540	1.8	1330	560	3	-	7	-			
63.30	27	3540	1.6	1330	560	3	-	7	-			
75.20	23	3540	1.3	1330	560	3	-	6	-			
Weight [lbs]		Stages		AD2		AD3						
K47		Large	Small									
K47		3	-	47		54						
KA47: -2 lbs / KAF47: +4.5 lbs / KF47: +7 lbs												

10.2.6 K47R37

K47R37 AD.. , $n_e = 1700$ rpm										3540 lb-in		
i [ratio]	n_a [rpm]	T_a max [lb-in]	P_e [HP]	$F_{Ra}^{(1)}$ [lb]	F_{Re} [lb]	Stages		ϕ (°/R) [']				
						Lg	Sm					
94	18	3540	1.1	1330	100	3	2	-	-			
99	17	3540	1.0	1330	100	3	2	-	-			
112	15	3540	0.92	1330	120	3	2	-	-			
131	13	3540	0.79	1330	130	3	2	-	-			
153	11	3540	0.67	1330	140	3	2	-	-			
171	9.9	3540	0.60	1330	150	3	2	-	-			
198	8.6	3540	0.52	1330	160	3	2	-	-			
225	7.6	3540	0.46	1330	160	3	2	-	-			
256	6.6	3540	0.40	1330	160	3	2	-	-			
289	5.9	3540	0.36	1330	160	3	2	-	-			
327	5.2	3540	0.31	1330	160	3	2	-	-			
375	4.5	3540	0.27	1330	170	3	2	-	-			
426	4.0	3540	0.24	1330	160	3	2	-	-			
495	3.4	3540	0.21	1330	170	3	2	-	-			
552	3.1	3540	0.19	1330	170	3	2	-	-			
639	2.7	3540	0.16	1330	170	3	2	-	-			
718	2.4	3540	0.14	1330	170	3	2	-	-			
831	2.0	3540	0.12	1330	170	3	2	-	-			
945	1.8	3540	0.11	1330	170	3	2	-	-			
1097	1.5	3540	0.09	1330	170	3	2	-	-			
1222	1.4	3540	0.08	1330	170	3	2	-	-			
1388	1.2	3540	0.08	1330	170	3	3	-	-			
1586	1.1	3540	0.07	1330	170	3	3	-	-			
1819	0.93	3540	0.06	1330	170	3	3	-	-			
2063	0.82	3540	0.05	1330	170	3	3	-	-			
2354	0.72	3540	0.04	1330	170	3	3	-	-			
2733	0.62	3540	0.04	1330	170	3	3	-	-			
3043	0.56	3540	0.03	1330	170	3	3	-	-			
3477	0.49	3540	0.03	1330	170	3	3	-	-			
3940	0.43	3540	0.03	1330	170	3	3	-	-			
4601	0.37	3540	0.02	1330	170	3	3	-	-			
5159	0.33	3540	0.02	1330	170	3	3	-	-			
5983	0.28	3540	0.02	1330	170	3	3	-	-			
6826	0.25	3540	0.02	1330	170	3	3	-	-			
7662	0.22	3540	0.01	1330	170	3	3	-	-			
8534	0.20	3540	0.01	1330	170	3	3	-	-			
10138	0.17	3540	0.01	1330	170	3	3	-	-			
94	18	3540	1.1	1330	370	3	2	-	-			
99	17	3540	1.0	1330	360	3	2	-	-			
112	15	3540	0.92	1330	370	3	2	-	-			
131	13	3540	0.79	1330	370	3	2	-	-			
153	11	3540	0.67	1330	380	3	2	-	-			
171	9.9	3540	0.60	1330	380	3	2	-	-			
198	8.6	3540	0.52	1330	390	3	2	-	-			
225	7.6	3540	0.46	1330	380	3	2	-	-			
256	6.6	3540	0.40	1330	390	3	2	-	-			
289	5.9	3540	0.36	1330	390	3	2	-	-			
327	5.2	3540	0.31	1330	390	3	2	-	-			
375	4.5	3540	0.27	1330	390	3	2	-	-			
426	4.0	3540	0.24	1330	390	3	2	-	-			
495	3.4	3540	0.21	1330	390	3	2	-	-			
552	3.1	3540	0.19	1330	390	3	2	-	-			
639	2.7	3540	0.16	1330	390	3	2	-	-			
718	2.4	3540	0.14	1330	400	3	2	-	-			
831	2.0	3540	0.12	1330	400	3	2	-	-			
945	1.8	3540	0.11	1330	400	3	2	-	-			
1097	1.5	3540	0.09	1330	400	3	2	-	-			
1222	1.4	3540	0.08	1330	400	3	2	-	-			
1388	1.2	3540	0.08	1330	400	3	3	-	-			



K47R37

AD1

K47R37

AD2

K47R37 AD.. , n_e = 1700 rpm 3540 lb-in

i [ratio]	n _a [rpm]	T _{a max} [lb-in]	P _e [HP]	F _{Ra} ¹⁾ [lb]	F _{Re} [lb]	Stages		φ _(/R) [']		
						Lg	Sm			
1586	1.1	3540	0.07	1330	400	3	3	-	-	K47R37 AD2
1819	0.93	3540	0.06	1330	400	3	3	-	-	
2063	0.82	3540	0.05	1330	400	3	3	-	-	
2354	0.72	3540	0.04	1330	400	3	3	-	-	
2733	0.62	3540	0.04	1330	400	3	3	-	-	
3043	0.56	3540	0.03	1330	400	3	3	-	-	
3477	0.49	3540	0.03	1330	400	3	3	-	-	
3940	0.43	3540	0.03	1330	400	3	3	-	-	
4601	0.37	3540	0.02	1330	400	3	3	-	-	
5159	0.33	3540	0.02	1330	400	3	3	-	-	
5983	0.28	3540	0.02	1330	400	3	3	-	-	
6826	0.25	3540	0.02	1330	400	3	3	-	-	
7662	0.22	3540	0.01	1330	400	3	3	-	-	
8534	0.20	3540	0.01	1330	400	3	3	-	-	
10138	0.17	3540	0.01	1330	400	3	3	-	-	



Weight [lbs]	Stages		AD1	AD2
	Large	Small		
K47R37	3	2	68	71
	3	3	69	71

KA47: -2 lbs / KAF47: +4.5 lbs / KF47: +7 lbs



10 K - Helical Bevel

K.. AD

10.2.7 K49

K49 AD.. , n _e = 1700 rpm										4430 lb-in		
i [ratio]	n _a [rpm]	T _{a max} [lb-in]	P _e [HP]	F _{Re} ¹⁾ [lb]	F _{Re} [lb]	Stages		φ _(/R) [']				
						Lg	Sm					
11.75	145	3980	10.1	800	210	2	-	-	-	-		
12.60	135	3720	8.3	1180	0	2	-	-	-	-		
13.38	127	4160	9.2	860	230	2	-	-	-	-		
15.05	113	2260	4.3	1420	220	2	-	-	-	-		
15.67	108	4340	8.2	920	230	2	-	-	-	-		
15.84	107	2300	4.1	1450	220	2	-	-	-	-		
17.67	96	4430	7.4	970	240	2	-	-	-	-		
18.04	94	2300	3.6	1520	220	2	-	-	-	-		
20.03	85	4430	6.6	1050	250	2	-	-	-	-		
21.00	81	1240	1.7	1740	110	2	-	-	-	-		
22.50	76	1330	1.7	1770	80	2	-	-	-	-		
22.83	74	4430	5.8	1130	260	2	-	-	-	-		
25.34	67	4430	5.2	1200	260	2	-	-	-	-	K49	AD2
28.95	59	4430	4.5	1290	270	2	-	-	-	-		
30.55	56	4430	4.3	1330	270	2	-	-	-	-		
34.81	49	4430	3.8	1420	280	2	-	-	-	-		
37.98	45	4430	3.5	1490	280	2	-	-	-	-		
42.10	40	4430	3.1	1610	280	2	-	-	-	-		
44.44	38	4430	3.0	1610	280	2	-	-	-	-		
50.29	34	4430	2.6	1720	290	2	-	-	-	-		
52.94	32	4430	2.5	1760	290	2	-	-	-	-		
60.27	28	4430	2.2	1870	290	2	-	-	-	-		
70.19	24	3940	1.7	2020	110	2	-	-	-	-		
75.20	23	4200	1.7	2020	90	2	-	-	-	-		
6.83	249	4430	18.3	780	40	2	-	-	-	-		
7.58	224	4430	16.5	820	80	2	-	-	-	-		
8.66	196	4430	14.5	880	120	2	-	-	-	-		
9.14	186	4430	13.7	910	130	2	-	-	-	-		
10.42	163	3500	9.5	1080	310	2	-	-	-	-		
11.37	150	3670	9.2	1100	300	2	-	-	-	-		
12.60	135	3720	8.4	1180	300	2	-	-	-	-		
13.30	128	3720	7.9	1180	300	2	-	-	-	-		
13.38	127	4160	9.3	860	450	2	-	-	-	-		
15.67	108	4340	8.3	920	450	2	-	-	-	-		
17.67	96	4430	7.5	970	460	2	-	-	-	-		
20.03	85	4430	6.6	1050	470	2	-	-	-	-		
22.83	74	4430	5.8	1130	470	2	-	-	-	-		
25.34	67	4430	5.2	1200	480	2	-	-	-	-		
28.95	59	4430	4.6	1290	490	2	-	-	-	-		
30.55	56	4430	4.3	1330	490	2	-	-	-	-		
34.81	49	4430	3.8	1420	490	2	-	-	-	-		
37.98	45	4430	3.5	1490	490	2	-	-	-	-		
44.44	38	4430	3.0	1610	500	2	-	-	-	-		
4.00	425	3850	27	430	570	2	-	-	-	-		
4.69	362	4120	25	420	580	2	-	-	-	-		
5.29	321	4290	23	460	580	2	-	-	-	-		
5.99	284	4430	21	580	590	2	-	-	-	-		
6.83	249	4430	18.4	780	610	2	-	-	-	-		
7.58	224	4430	16.6	820	620	2	-	-	-	-		
8.66	196	4430	14.5	880	640	2	-	-	-	-		
9.14	186	4430	13.8	910	640	2	-	-	-	-		
13.38	127	4160	9.3	860	850	2	-	-	-	-		
15.67	108	4340	8.3	920	850	2	-	-	-	-		
17.67	96	4430	7.5	970	860	2	-	-	-	-		
20.03	85	4430	6.6	1050	860	2	-	-	-	-		
22.83	74	4430	5.8	1130	870	2	-	-	-	-		
25.34	67	4430	5.3	1200	870	2	-	-	-	-		
28.95	59	4430	4.6	1290	880	2	-	-	-	-		
30.55	56	4430	4.4	1330	880	2	-	-	-	-		
Weight [lbs]		Stages		AD2		AD3		AD4				
		Large	Small									
K49		3	-	72		79		92				
KA49: -6 lbs / KAF49: +5 lbs / KF49: +4 lbs												

10.2.8 K49R37

K49R37 AD.. , n _e = 1700 rpm										4430 lb-in		
i [ratio]	n _a [rpm]	T _a max [lb-in]	P _e [HP]	F _{Ra} ¹⁾ [lb]	F _{Re} [lb]	Stages		φ _(/R) [']				
						Lg	Sm					
99	17	4430	1.4	2020	100	2	2	-	-			
125	14	4430	1.1	2020	110	2	2	-	-			
152	11	4430	0.93	2020	140	2	2	-	-			
176	9.7	4430	0.80	2020	130	2	2	-	-			
193	8.8	4430	0.73	2020	120	2	2	-	-			
217	7.8	4430	0.66	2020	150	2	2	-	-			
243	7.0	4430	0.60	2020	160	2	2	-	-			
274	6.2	4430	0.54	2020	160	2	2	-	-			
300	5.7	4430	0.49	2020	160	2	2	-	-			
330	5.2	4430	0.45	2020	160	2	2	-	-			
360	4.7	4430	0.42	2020	160	2	2	-	-			
401	4.2	4430	0.39	2020	160	2	2	-	-			
449	3.8	4430	0.35	2020	160	2	2	-	-			
501	3.4	4430	0.32	2020	170	2	2	-	-			
543	3.1	4430	0.29	2020	160	2	2	-	-			
595	2.9	4430	0.27	2020	170	2	2	-	-			
645	2.6	4430	0.24	2020	160	2	2	-	-			
701	2.4	4430	0.24	2020	170	2	2	-	-			
802	2.1	4430	0.21	2020	170	2	2	-	-			
908	1.9	4430	0.19	2020	170	2	2	-	-			
1000	1.7	4430	0.18	2020	170	2	3	-	-			
1120	1.5	4430	0.16	2020	170	2	2	-	-			
1228	1.4	4430	0.16	2020	170	2	3	-	-			
1309	1.3	4430	0.14	2020	170	2	2	-	-			
1424	1.2	4430	0.13	2020	170	2	2	-	-			
1521	1.1	4430	0.14	2020	170	2	3	-	-			
1632	1.0	4430	0.13	2020	170	2	3	-	-			
1741	0.98	4430	0.12	2020	170	2	3	-	-			
1941	0.88	4430	0.11	2020	170	2	3	-	-			
2118	0.80	4430	0.10	2020	170	2	3	-	-			
2372	0.72	4430	0.10	2020	170	2	3	-	-			
2545	0.67	4430	0.09	2020	170	2	3	-	-			
2773	0.61	4430	0.09	2020	170	2	3	-	-			
3081	0.55	4430	0.09	2020	170	2	3	-	-			
3580	0.47	4430	0.07	2020	170	2	3	-	-			
4034	0.42	4430	0.07	2020	170	2	3	-	-			
5120	0.33	4430	0.06	2020	170	2	3	-	-			
5991	0.28	4430	0.06	2020	170	2	3	-	-			
7137	0.24	4430	0.06	2020	170	2	3	-	-			
99	17	4430	1.4	2020	360	2	2	-	-			
125	14	4430	1.1	2020	370	2	2	-	-			
152	11	4430	0.94	2020	380	2	2	-	-			
176	9.7	4430	0.81	2020	380	2	2	-	-			
193	8.8	4430	0.74	2020	370	2	2	-	-			
217	7.8	4430	0.67	2020	380	2	2	-	-			
243	7.0	4430	0.62	2020	390	2	2	-	-			
274	6.2	4430	0.55	2020	390	2	2	-	-			
300	5.7	4430	0.50	2020	380	2	2	-	-			
330	5.2	4430	0.47	2020	390	2	2	-	-			
360	4.7	4430	0.43	2020	390	2	2	-	-			
401	4.2	4430	0.40	2020	390	2	2	-	-			
449	3.8	4430	0.36	2020	390	2	2	-	-			
501	3.4	4430	0.33	2020	390	2	2	-	-			
543	3.1	4430	0.30	2020	390	2	2	-	-			
595	2.9	4430	0.28	2020	390	2	2	-	-			
645	2.6	4430	0.25	2020	390	2	2	-	-			
701	2.4	4430	0.25	2020	390	2	2	-	-			
802	2.1	4430	0.22	2020	390	2	2	-	-			

K49R37

AD1



K49R37

AD2

10 K - Helical Bevel

K.. AD

K49R37 AD.. , $n_e = 1700$ rpm 4430 lb-in

i [ratio]	n_a [rpm]	T_a max [lb-in]	P_e [HP]	$F_{Ra}^{1)}$ [lb]	F_{Re} [lb]	Stages		ϕ (/R) [']		
						Lg	Sm			
908	1.9	4430	0.20	2020	390	2	2	-	-	K49R37 AD2
1000	1.7	4430	0.20	2020	400	2	3	-	-	
1120	1.5	4430	0.17	2020	400	2	2	-	-	
1228	1.4	4430	0.18	2020	400	2	3	-	-	
1309	1.3	4430	0.15	2020	400	2	2	-	-	
1424	1.2	4430	0.14	2020	400	2	2	-	-	
1521	1.1	4430	0.15	2020	400	2	3	-	-	
1632	1.0	4430	0.14	2020	400	2	3	-	-	
1741	0.98	4430	0.13	2020	400	2	3	-	-	
1941	0.88	4430	0.12	2020	400	2	3	-	-	
2118	0.80	4430	0.11	2020	400	2	3	-	-	
2372	0.72	4430	0.11	2020	400	2	3	-	-	
2545	0.67	4430	0.11	2020	400	2	3	-	-	
2773	0.61	4430	0.10	2020	400	2	3	-	-	
3081	0.55	4430	0.10	2020	400	2	3	-	-	
3580	0.47	4430	0.09	2020	400	2	3	-	-	

Weight [lbs]	Stages		AD1	AD2
	Large	Small		
K49R37	2	2	89	92
	2	3	90	92

KA49: -6 lbs / KAF49: +5 lbs / KF49: +4 lbs

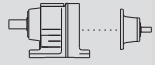

10.2.9 K57

K57 AD.. , n _e = 1700 rpm										5310 lb-in	
i [ratio]	n _a [rpm]	T _a max [lb-in]	P _e [HP]	F _{Ra} ¹⁾ [lb]	F _{Re} [lb]	Stages		φ (/R) [']			
						Lg	Sm			K57	AD2
13.25	128	4250	9.1	1090	210	3	-	7	M2-6		
15.22	112	4650	8.6	1110	200	3	-	7	M2		
17.57	97	4910	7.9	1160	200	3	-	7	-		
19.34	88	5090	7.4	1190	200	3	-	7	-		
22.71	75	5310	6.6	1270	210	3	-	7	-		
24.05	71	5310	6.2	1310	210	3	-	7	-		
27.34	62	5310	5.5	1400	220	3	-	7	-		
30.28	56	5310	4.9	1480	230	3	-	7	-		
35.70	48	5310	4.2	1620	230	3	-	7	-		
38.49	44	5310	3.9	1680	310	3	-	6	-		
44.43	38	5310	3.4	1720	320	3	-	6	-	K57	AD2
48.89	35	5310	3.1	1720	320	3	-	6	-		
57.42	30	5310	2.6	1720	320	3	-	6	-		
60.81	28	5310	2.5	1720	330	3	-	6	-		
69.12	25	5310	2.2	1720	330	3	-	6	-		
76.56	22	5310	2.0	1720	330	3	-	6	-		
90.26	19	5310	1.7	1720	330	3	-	6	-		
102.88	17	5310	1.5	1720	240	3	-	6	-		
108.29	16	5310	1.4	1720	240	3	-	6	-		
123.85	14	5310	1.2	1720	250	3	-	6	-		
145.14	12	5310	1.0	1720	250	3	-	6	-		
4.69	362	2660	16.0	770	320	3	-	11	M1-6		
6.57	259	3050	13.1	850	340	3	-	10	M1-6		
7.55	225	3230	12.1	880	340	3	-	10	M1-6		
8.71	195	3450	11.2	910	340	3	-	10	M1-6		
9.59	177	3580	10.5	940	340	3	-	10	M1-6		
11.26	151	3670	9.2	1010	350	3	-	9	M2		
11.92	143	3670	8.7	1040	360	3	-	9	-		
13.25	128	4510	9.6	1050	410	3	-	7	M1-6		
15.22	112	4730	8.8	1090	410	3	-	7	M2,4,6		
17.57	97	4910	7.9	1160	420	3	-	7	-		
19.34	88	5090	7.4	1190	420	3	-	7	-		
22.71	75	5310	6.6	1270	430	3	-	7	-		
24.05	71	5310	6.2	1310	430	3	-	7	-	K57	AD3
27.34	62	5310	5.5	1400	430	3	-	7	-		
30.28	56	5310	4.9	1480	440	3	-	7	-		
35.70	48	5310	4.2	1620	450	3	-	7	-		
38.49	44	5310	3.9	1680	520	3	-	6	-		
44.43	38	5310	3.4	1720	530	3	-	6	-		
48.89	35	5310	3.1	1720	530	3	-	6	-		
57.42	30	5310	2.6	1720	540	3	-	6	-		
60.81	28	5310	2.5	1720	540	3	-	6	-		
69.12	25	5310	2.2	1720	540	3	-	6	-		
76.56	22	5310	2.0	1720	540	3	-	6	-		
90.26	19	5310	1.7	1720	550	3	-	6	-		
Weight [lbs]		Stages		AD2		AD3					
		Large	Small								
K57		3	-	60		67					
KA57: -5 lbs / KAF57: +8 lbs / KF57: +10 lbs											



10 K - Helical Bevel

K.. AD

10.2.10 K57R37

K57R37 AD.. , $n_e = 1700$ rpm										5310 lb-in		
i [ratio]	n_a [rpm]	$T_{a \max}$ [lb-in]	P_e [HP]	$F_{Ra}^{(1)}$ [lb]	F_{Re} [lb]	Stages		ϕ (°/R) [']				
						Lg	Sm					
97	18	4870	1.5	1810	80	3	2	-	-			
111	15	5310	1.4	1720	80	3	2	-	-			
129	13	5310	1.2	1720	70	3	2	-	-			
145	12	5310	1.1	1720	110	3	2	-	-			
166	10	5310	0.93	1720	120	3	2	-	-			
192	8.9	5310	0.80	1720	130	3	2	-	-			
215	7.9	5310	0.72	1720	140	3	2	-	-			
246	6.9	5310	0.63	1720	150	3	2	-	-			
280	6.1	5310	0.55	1720	160	3	2	-	-			
319	5.3	5310	0.48	1720	150	3	2	-	-			
362	4.7	5310	0.43	1720	160	3	2	-	-			
421	4.0	5310	0.37	1720	160	3	2	-	-			
473	3.6	5310	0.33	1720	160	3	2	-	-			
544	3.1	5310	0.28	1720	160	3	2	-	-			
615	2.8	5310	0.25	1720	170	3	2	-	-			
699	2.4	5310	0.22	1720	170	3	2	-	-			
806	2.1	5310	0.19	1720	170	3	2	-	-			
906	1.9	5310	0.17	1720	170	3	2	-	-			
1036	1.6	5310	0.15	1720	170	3	2	-	-			
1174	1.4	5310	0.13	1720	170	3	2	-	-			K57R37 AD1
1354	1.3	5310	0.11	1720	170	3	2	-	-			
1539	1.1	5310	0.10	1720	170	3	2	-	-			
1743	0.98	5310	0.09	1720	170	3	2	-	-			
1986	0.86	5310	0.08	1720	170	3	3	-	-			
2249	0.76	5310	0.07	1720	170	3	3	-	-			
2593	0.66	5310	0.06	1720	170	3	3	-	-			
2924	0.58	5310	0.05	1720	170	3	3	-	-			
3390	0.50	5310	0.05	1720	170	3	3	-	-			
3854	0.44	5310	0.04	1720	170	3	3	-	-			
4340	0.39	5310	0.04	1720	170	3	3	-	-			
5033	0.34	5310	0.03	1720	170	3	3	-	-			
5662	0.30	5310	0.03	1720	170	3	3	-	-			
6478	0.26	5310	0.02	1720	170	3	3	-	-			
7277	0.23	5310	0.02	1720	170	3	3	-	-			
8547	0.20	5310	0.02	1720	170	3	3	-	-			
9503	0.18	5310	0.02	1720	170	3	3	-	-			
11162	0.15	5310	0.01	1720	170	3	3	-	-			
12169	0.14	5310	0.01	1720	170	3	3	-	-			
97	18	5310	1.6	1720	310	3	2	-	-			
111	15	5310	1.4	1720	340	3	2	-	-			
129	13	5310	1.2	1720	330	3	2	-	-			
145	12	5310	1.1	1720	370	3	2	-	-			
166	10	5310	0.93	1720	370	3	2	-	-			
192	8.9	5310	0.80	1720	380	3	2	-	-			
215	7.9	5310	0.72	1720	380	3	2	-	-			
246	6.9	5310	0.63	1720	380	3	2	-	-			
280	6.1	5310	0.55	1720	380	3	2	-	-			
319	5.3	5310	0.48	1720	380	3	2	-	-			
362	4.7	5310	0.43	1720	390	3	2	-	-			
421	4.0	5310	0.37	1720	390	3	2	-	-			
473	3.6	5310	0.33	1720	390	3	2	-	-			
544	3.1	5310	0.28	1720	390	3	2	-	-			
615	2.8	5310	0.25	1720	390	3	2	-	-			
699	2.4	5310	0.22	1720	390	3	2	-	-			
806	2.1	5310	0.19	1720	390	3	2	-	-			
906	1.9	5310	0.17	1720	400	3	2	-	-			
1036	1.6	5310	0.15	1720	390	3	2	-	-			
1174	1.4	5310	0.13	1720	390	3	2	-	-			K57R37 AD2

K57R37 AD.. , n_e = 1700 rpm 5310 lb-in

i [ratio]	n _a [rpm]	T _{a max} [lb-in]	P _e [HP]	F _{Ra} ¹⁾ [lb]	F _{Re} [lb]	Stages		φ _(/R) [']		
						Lg	Sm			
1354	1.3	5310	0.11	1720	400	3	2	-	-	K57R37 AD2
1539	1.1	5310	0.10	1720	400	3	2	-	-	
1743	0.98	5310	0.09	1720	400	3	2	-	-	
1986	0.86	5310	0.08	1720	400	3	3	-	-	
2249	0.76	5310	0.07	1720	400	3	3	-	-	
2593	0.66	5310	0.06	1720	400	3	3	-	-	
2924	0.58	5310	0.05	1720	400	3	3	-	-	
3390	0.50	5310	0.05	1720	400	3	3	-	-	
3854	0.44	5310	0.04	1720	400	3	3	-	-	
4340	0.39	5310	0.04	1720	400	3	3	-	-	
5033	0.34	5310	0.03	1720	400	3	3	-	-	
5662	0.30	5310	0.03	1720	400	3	3	-	-	
6478	0.26	5310	0.02	1720	400	3	3	-	-	
7277	0.23	5310	0.02	1720	400	3	3	-	-	
8547	0.20	5310	0.02	1720	400	3	3	-	-	
9503	0.18	5310	0.02	1720	400	3	3	-	-	
11162	0.15	5310	0.01	1720	400	3	3	-	-	
12169	0.14	5310	0.01	1720	400	3	3	-	-	



Weight [lbs]	Stages		AD1	AD2
	Large	Small		
K57R37	3	2	81	84
	3	3	82	84

KA57: -5 lbs / KAF57: +8 lbs / KF57: +10 lbs



10 K - Helical Bevel

K.. AD

10.2.11 K67

K67 AD.. , $n_e = 1700$ rpm										7260 lb-in	
i [ratio]	n_a [rpm]	$T_{a \max}$ [lb-in]	P_e [HP]	$F_{Ra}^{1)}$ [lb]	F_{Re} [lb]	Stages		ϕ (R) [']			
						Lg	Sm				
35.62	48	7260	5.8	2320	170	3	-	7	-		
38.39	44	7080	5.2	2360	280	3	-	6	-		
44.32	38	7260	4.6	2320	280	3	-	6	-		
48.77	35	7260	4.2	2320	290	3	-	6	-		
57.28	30	7260	3.6	2320	300	3	-	6	-		
60.66	28	7260	3.4	2320	300	3	-	6	-		
68.95	25	7260	3.0	2320	300	3	-	6	-		
76.37	22	7260	2.7	2320	310	3	-	6	-		
90.04	19	7260	2.3	2320	310	3	-	6	-		
102.62	17	7260	2.0	2320	310	3	-	6	-		
108.03	16	7260	1.9	2320	310	3	-	6	-		
123.54	14	7260	1.7	2320	320	3	-	6	-		
144.79	12	7260	1.4	2320	160	3	-	6	-		
5.20	327	3100	16.8	2060	310	3	-	10	M1-6		
7.28	234	3720	14.4	2230	310	3	-	9	M1-6		
8.37	203	3890	13.1	2320	320	3	-	9	M1-6		
9.66	176	4250	12.4	2400	310	3	-	9	M1-6		
10.63	160	4430	11.8	2460	310	3	-	9	M1-6		
12.48	136	4690	10.6	2570	310	3	-	9	M2		
13.22	129	5930	12.7	2560	350	3	-	8	M1-6		
15.19	112	6200	11.5	2530	350	3	-	8	M1-6		
17.54	97	6550	10.5	2470	360	3	-	7	M2,4,6		
19.30	88	6730	9.8	2430	360	3	-	7	-		
22.66	75	6900	8.6	2400	370	3	-	7	-		
24.00	71	7080	8.3	2360	370	3	-	7	-		
27.28	62	7260	7.5	2320	370	3	-	7	-		
30.22	56	7260	6.8	2320	380	3	-	7	-		
35.62	48	7260	5.8	2320	390	3	-	7	-		
38.39	44	7080	5.2	2360	490	3	-	6	-		
44.32	38	7260	4.6	2320	500	3	-	6	-		
48.77	35	7260	4.2	2320	500	3	-	6	-		
57.28	30	7260	3.6	2320	510	3	-	6	-		
60.66	28	7260	3.4	2320	510	3	-	6	-		
68.95	25	7260	3.0	2320	520	3	-	6	-		
76.37	22	7260	2.7	2320	520	3	-	6	-		
90.04	19	7260	2.3	2320	520	3	-	6	-		
Weight [lbs]		Stages		AD2		AD3					
		Large	Small								
K67		3	-	73		80					
KA67: -6 lbs / KAF67: +7 lbs / KF67: +12 lbs											

10.2.12 K67R37

K67R37 AD.. , n _e = 1700 rpm										7260 lb-in	
i [ratio]	n _a [rpm]	T _{a max} [lb-in]	P _e [HP]	F _{Ra} ¹⁾ [lb]	F _{Re} [lb]	Stages		φ _(/R) [']			
						Lg	Sm				
122	14	6110	1.5	2550	80	3	2	-	-		
144	12	7170	1.4	2340	80	3	2	-	-		
166	10	7260	1.3	2320	100	3	2	-	-		
191	8.9	7260	1.1	2320	100	3	2	-	-		
217	7.8	7260	0.97	2320	130	3	2	-	-		
246	6.9	7260	0.86	2320	130	3	2	-	-		
279	6.1	7260	0.76	2320	140	3	2	-	-		
323	5.3	7260	0.65	2320	140	3	2	-	-		
361	4.7	7260	0.59	2320	140	3	2	-	-		
420	4.0	7260	0.50	2320	160	3	2	-	-		
471	3.6	7260	0.45	2320	150	3	2	-	-		
542	3.1	7260	0.39	2320	160	3	2	-	-		
613	2.8	7260	0.34	2320	160	3	2	-	-		
697	2.4	7260	0.30	2320	160	3	2	-	-		
793	2.1	7260	0.27	2320	160	3	2	-	-		
903	1.9	7260	0.23	2320	170	3	2	-	-		
1034	1.6	7260	0.20	2320	160	3	2	-	-		
1171	1.5	7260	0.18	2320	160	3	2	-	-		
1351	1.3	7260	0.16	2320	170	3	2	-	-		
1535	1.1	7260	0.14	2320	170	3	2	-	-		
1739	0.98	7260	0.12	2320	170	3	2	-	-		
1981	0.86	7260	0.11	2320	170	3	3	-	-		
2244	0.76	7260	0.10	2320	170	3	3	-	-		
2532	0.67	7260	0.08	2320	170	3	3	-	-		
2917	0.58	7260	0.07	2320	170	3	3	-	-		
3315	0.51	7260	0.06	2320	170	3	3	-	-		
3750	0.45	7260	0.06	2320	170	3	3	-	-		
4329	0.39	7260	0.05	2320	170	3	3	-	-		
4846	0.35	7260	0.04	2320	170	3	3	-	-		
5648	0.30	7260	0.04	2320	170	3	3	-	-		
6462	0.26	7260	0.03	2320	170	3	3	-	-		
7259	0.23	7260	0.03	2320	170	3	3	-	-		
8173	0.21	7260	0.03	2320	170	3	3	-	-		
9479	0.18	7260	0.02	2320	170	3	3	-	-		
11134	0.15	7260	0.02	2320	170	3	3	-	-		
12139	0.14	7260	0.02	2320	170	3	3	-	-		
122	14	7260	1.7	2320	350	3	2	-	-		
144	12	7260	1.5	2320	330	3	2	-	-		
166	10	7260	1.3	2320	360	3	2	-	-		
191	8.9	7260	1.1	2320	370	3	2	-	-		
217	7.8	7260	0.97	2320	370	3	2	-	-		
246	6.9	7260	0.86	2320	380	3	2	-	-		
279	6.1	7260	0.76	2320	380	3	2	-	-		
323	5.3	7260	0.65	2320	380	3	2	-	-		
361	4.7	7260	0.59	2320	380	3	2	-	-		
420	4.0	7260	0.50	2320	390	3	2	-	-		
471	3.6	7260	0.45	2320	380	3	2	-	-		
542	3.1	7260	0.39	2320	390	3	2	-	-		
613	2.8	7260	0.34	2320	390	3	2	-	-		
697	2.4	7260	0.30	2320	390	3	2	-	-		
793	2.1	7260	0.27	2320	390	3	2	-	-		
903	1.9	7260	0.23	2320	390	3	2	-	-		
1034	1.6	7260	0.20	2320	390	3	2	-	-		
1171	1.5	7260	0.18	2320	390	3	2	-	-		
1351	1.3	7260	0.16	2320	390	3	2	-	-		
1535	1.1	7260	0.14	2320	390	3	2	-	-		
1739	0.98	7260	0.12	2320	400	3	2	-	-		

K67R37



AD1

K67R37

AD2

K67R37 AD.. , $n_e = 1700$ rpm



7260 lb-in

i [ratio]	n_a [rpm]	T_a max [lb-in]	P_e [HP]	$F_{Ra}^{1)}$ [lb]	F_{Re} [lb]	Stages		ϕ (/R) [']		
						Lg	Sm			
1981	0.86	7260	0.11	2320	400	3	3	-	-	K67R37 AD2
2244	0.76	7260	0.10	2320	400	3	3	-	-	
2532	0.67	7260	0.08	2320	400	3	3	-	-	
2917	0.58	7260	0.07	2320	400	3	3	-	-	
3315	0.51	7260	0.06	2320	400	3	3	-	-	
3750	0.45	7260	0.06	2320	400	3	3	-	-	
4329	0.39	7260	0.05	2320	400	3	3	-	-	
4846	0.35	7260	0.04	2320	400	3	3	-	-	
5648	0.30	7260	0.04	2320	400	3	3	-	-	
6462	0.26	7260	0.03	2320	400	3	3	-	-	
7259	0.23	7260	0.03	2320	400	3	3	-	-	
8173	0.21	7260	0.03	2320	400	3	3	-	-	
9479	0.18	7260	0.02	2320	400	3	3	-	-	
11134	0.15	7260	0.02	2320	400	3	3	-	-	
12139	0.14	7260	0.02	2320	400	3	3	-	-	

Weight [lbs]	Stages		AD1	AD2
	Large	Small		
K67R37	3	2	94	97
	3	3	95	97

KA67: -6 lbs / KAF67: +7 lbs / KF67: +12 lbs

10.2.13 K77

K77 AD.. , n _e = 1700 rpm										13720 lb-in	
i [ratio]	n _a [rpm]	T _a max [lb-in]	P _e [HP]	F _{Ra} ¹⁾ [lb]	F _{Re} [lb]	Stages		φ (/R) [']			
						Lg	Sm				
40.04	42	13540	9.5	3490	210	3	-	6	-		
45.16	38	13720	8.6	3460	220	3	-	6	-		
51.18	33	13720	7.6	3460	230	3	-	6	-		
58.34	29	13720	6.6	3460	240	3	-	6	-		
64.75	26	13720	6.0	3460	250	3	-	5	-		
73.99	23	13720	5.2	3460	250	3	-	5	-		
78.07	22	13720	5.0	3460	250	3	-	5	-		
88.97	19	13720	4.4	3460	260	3	-	5	-		
97.05	18	13720	4.0	3460	260	3	-	5	-		
113.56	15	13720	3.4	3460	270	3	-	5	-		
128.52	13	13720	3.0	3460	280	3	-	5	-		
135.28	13	13720	2.9	3460	280	3	-	5	-		
154.02	11	13720	2.5	3460	280	3	-	5	-		
179.37	9.5	10270	1.6	3960	120	3	-	5	-		
192.18	8.8	10970	1.6	3880	90	3	-	5	-		
30.89	55	13720	12.5	3460	210	3	-	6	-		
35.20	48	12480	10.0	3660	300	3	-	6	-		
38.39	44	13190	9.7	3550	270	3	-	6	-		
40.04	42	13720	9.7	3460	430	3	-	6	M2		
45.16	38	13720	8.6	3460	440	3	-	6	-		
51.18	33	13720	7.6	3460	450	3	-	6	-		
58.34	29	13720	6.6	3460	460	3	-	6	-		
64.75	26	13720	6.0	3460	460	3	-	5	-		
73.99	23	13720	5.2	3460	470	3	-	5	-		
78.07	22	13720	5.0	3460	470	3	-	5	-		
88.97	19	13720	4.4	3460	480	3	-	5	-		
97.05	18	13720	4.0	3460	480	3	-	5	-		
113.56	15	13720	3.4	3460	480	3	-	5	-		
7.24	235	7260	28	2710	570	3	-	8	M1-6		
8.48	200	7880	26	2810	560	3	-	8	M1-6		
9.56	178	8320	25	2890	560	3	-	8	M1-6		
10.84	157	8760	23	2990	560	3	-	8	M1-6		
12.36	138	8850	20	3140	580	3	-	8	M1-6		
13.52	126	11860	25	3060	620	3	-	7	M1-6		
15.84	107	12390	22	3210	630	3	-	6	M1-6		
17.87	95	12830	20	3330	640	3	-	6	M1-6		
20.25	84	13280	18.5	3460	640	3	-	6	M1-6		
23.08	74	13720	16.8	3460	650	3	-	6	M1-6		
25.62	66	13720	15.1	3460	660	3	-	6	M2		
29.27	58	13720	13.2	3460	680	3	-	6	-		
30.89	55	13720	12.5	3460	680	3	-	6	-		
40.04	42	13720	9.7	3460	830	3	-	6	M2		
45.16	38	13720	8.6	3460	840	3	-	6	-		
51.18	33	13720	7.6	3460	840	3	-	6	-		
58.34	29	13720	6.6	3460	850	3	-	6	-		
64.75	26	13720	6.0	3460	860	3	-	5	-		
73.99	23	13720	5.2	3460	860	3	-	5	-		
78.07	22	13720	5.0	3460	870	3	-	5	-		
Weight [lbs]	Stages		AD2	AD3	AD4						
	Large	Small									
K77	3	-	128	135	148						

KA77: -17 lbs / KAF77: +1 lb / KF77: +18 lbs



10 K - Helical Bevel

K.. AD

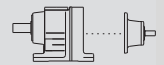
10.2.14 K77R37

K77R37 AD.. , n _e = 1700 rpm										13720 lb-in		
i [ratio]	n _a [rpm]	T _a max [lb-in]	P _e [HP]	F _{Ra} ¹⁾ [lb]	F _{Re} [lb]	Stages		φ _(/R) [']				
						Lg	Sm					
328	5.2	13720	1.2	3460	80	3	2	-	-			
367	4.6	13720	1.1	3460	80	3	2	-	-			
428	4.0	13720	0.93	3460	120	3	2	-	-			
485	3.5	13720	0.82	3460	130	3	2	-	-			
552	3.1	13720	0.72	3460	140	3	2	-	-			
622	2.7	13720	0.64	3460	150	3	2	-	-			
709	2.4	13720	0.56	3460	160	3	2	-	-			
815	2.1	13720	0.49	3460	140	3	2	-	-			
924	1.8	13720	0.43	3460	150	3	2	-	-			
1053	1.6	13720	0.38	3460	150	3	2	-	-			
1218	1.4	13720	0.33	3460	160	3	2	-	-			
1388	1.2	13720	0.29	3460	160	3	2	-	-			
1514	1.1	13720	0.26	3460	160	3	2	-	-			
1772	0.96	13720	0.23	3460	160	3	2	-	-			
2050	0.83	13720	0.19	3460	160	3	2	-	-			
2370	0.72	13720	0.17	3460	170	3	3	-	-		K77R37	AD1
2717	0.63	13720	0.15	3460	170	3	3	-	-			
2901	0.59	13720	0.14	3460	170	3	3	-	-			
3485	0.49	13720	0.12	3460	170	3	3	-	-			
3961	0.43	13720	0.10	3460	170	3	3	-	-			
4489	0.38	13720	0.09	3460	170	3	3	-	-			
5089	0.33	13720	0.08	3460	170	3	3	-	-			
5774	0.29	13720	0.07	3460	170	3	3	-	-			
6606	0.26	13720	0.06	3460	170	3	3	-	-			
7528	0.23	13720	0.05	3460	170	3	3	-	-			
8809	0.19	13720	0.05	3460	170	3	3	-	-			
10217	0.17	13720	0.04	3460	170	3	3	-	-			
11955	0.14	13720	0.03	3460	170	3	3	-	-			
14043	0.12	13720	0.03	3460	170	3	3	-	-			
15310	0.11	13720	0.03	3460	170	3	3	-	-			
154	11	13720	2.6	3460	330	3	2	-	-			
175	9.7	13720	2.3	3460	340	3	2	-	-			
195	8.7	13720	2.0	3460	340	3	2	-	-			
221	7.7	13720	1.8	3460	340	3	2	-	-			
252	6.7	13720	1.6	3460	310	3	2	-	-			
290	5.9	13720	1.4	3460	300	3	2	-	-			
328	5.2	13720	1.2	3460	330	3	2	-	-			
367	4.6	13720	1.1	3460	340	3	2	-	-			
428	4.0	13720	0.93	3460	370	3	2	-	-			
485	3.5	13720	0.82	3460	380	3	2	-	-			
552	3.1	13720	0.72	3460	380	3	2	-	-			
622	2.7	13720	0.64	3460	380	3	2	-	-			
709	2.4	13720	0.56	3460	390	3	2	-	-			
815	2.1	13720	0.49	3460	380	3	2	-	-			
924	1.8	13720	0.43	3460	380	3	2	-	-			
1053	1.6	13720	0.38	3460	380	3	2	-	-			
1218	1.4	13720	0.33	3460	390	3	2	-	-			
1388	1.2	13720	0.29	3460	390	3	2	-	-			
1514	1.1	13720	0.26	3460	390	3	2	-	-		K77R37	AD2
1772	0.96	13720	0.23	3460	390	3	2	-	-			
2050	0.83	13720	0.19	3460	390	3	2	-	-			
2370	0.72	13720	0.17	3460	400	3	3	-	-			
2717	0.63	13720	0.15	3460	400	3	3	-	-			
2901	0.59	13720	0.14	3460	400	3	3	-	-			
3485	0.49	13720	0.12	3460	400	3	3	-	-			
3961	0.43	13720	0.10	3460	400	3	3	-	-			
4489	0.38	13720	0.09	3460	400	3	3	-	-			
5089	0.33	13720	0.08	3460	400	3	3	-	-			
5774	0.29	13720	0.07	3460	400	3	3	-	-			
6606	0.26	13720	0.06	3460	400	3	3	-	-			
7528	0.23	13720	0.05	3460	400	3	3	-	-			
8809	0.19	13720	0.05	3460	400	3	3	-	-			
10217	0.17	13720	0.04	3460	400	3	3	-	-			
11955	0.14	13720	0.03	3460	400	3	3	-	-			
14043	0.12	13720	0.03	3460	400	3	3	-	-			
15310	0.11	13720	0.03	3460	400	3	3	-	-			
Weight [lbs]	Stages		AD1		AD2							
	Large	Small										
K77R37	3	2	147		150							
	3	3	148		150							
KA77: -17 lbs / KAF77: +1 lb / KF77: +18 lbs												



10.2.15 K87

K87 AD.. , n _e = 1700 rpm										23900 lb-in		
i [ratio]	n _a [rpm]	T _a max [lb-in]	P _e [HP]	F _{RA} ¹⁾ [lb]	F _{Re} [lb]	Stages		φ (/R) [']			K87	AD2
						Lg	Sm					
86.34	20	23900	7.8	6130	200	3	-	5	-			
102.71	17	23900	6.6	6130	210	3	-	5	-			
115.82	15	23900	5.8	6130	220	3	-	5	-			
126.91	13	23900	5.3	6130	220	3	-	5	-			
147.32	12	23900	4.6	6130	230	3	-	5	-			
164.34	10	23900	4.1	6130	230	3	-	5	-			
174.19	9.8	23900	3.9	6130	230	3	-	5	-			
197.37	8.6	23900	3.4	6130	240	3	-	5	-			
36.52	47	22130	17.1	4400	340	3	-	6	M1-6			
44.02	39	23010	14.8	4700	360	3	-	6	M2-6			
49.16	35	23900	13.7	4850	360	3	-	5	M2			
56.64	30	23900	11.9	5160	370	3	-	5	-			
63.00	27	23900	10.7	5410	380	3	-	5	-			
70.46	24	23900	9.6	5680	390	3	-	5	-			
79.34	21	23900	8.5	5970	400	3	-	5	-			
86.34	20	23900	7.8	6130	400	3	-	5	-			
102.71	17	23900	6.6	6130	410	3	-	5	-			
115.82	15	23900	5.8	6130	410	3	-	5	-			
126.91	13	23900	5.3	6130	420	3	-	5	-			
147.32	12	23900	4.6	6130	420	3	-	5	-			
7.21	236	10440	41	2840	500	3	-	7	M1-6			
8.29	205	11510	39	2890	450	3	-	7	M1-6			
10.00	170	12740	36	2990	430	3	-	7	M1-6			
11.17	152	13280	34	3080	430	3	-	7	M1-6			
12.56	135	17700	40	3030	530	3	-	6	M1-6			
14.45	118	18590	36	3150	530	3	-	6	M1-6			
16.00	106	15930	28	3290	350	3	-	6	M1-6			
17.42	98	19470	32	3350	550	3	-	6	M1-6			
19.45	87	20360	30	3440	550	3	-	6	M1-6			
22.41	76	20360	26	3680	580	3	-	6	M1-6			
24.92	68	22130	25	3680	560	3	-	6	M1-6			
27.88	61	23010	23	3800	560	3	-	6	M1-6			
31.39	54	23900	21	3930	550	3	-	6	M2			
36.52	47	22130	17.1	4400	770	3	-	6	M1-6			
44.02	39	23010	14.8	4700	780	3	-	6	M2-6			
49.16	35	23900	13.7	4850	780	3	-	5	M2,4,6			
56.64	30	23900	11.9	5160	790	3	-	5	-			
63.00	27	23900	10.7	5410	800	3	-	5	-			
70.46	24	23900	9.6	5680	810	3	-	5	-			
79.34	21	23900	8.5	5970	810	3	-	5	-			
86.34	20	23900	7.8	6130	820	3	-	5	-			
102.71	17	23900	6.6	6130	830	3	-	5	-			
7.21	236	11510	45	2720	1150	3	-	7	M1-6			
8.29	205	12390	42	2790	1140	3	-	7	M1-6			
10.00	170	13280	37	2930	1150	3	-	7	M1-6			
11.17	152	13280	34	3080	1170	3	-	7	M1-6			
12.56	135	17700	40	3030	1210	3	-	6	M1-6			
14.45	118	18590	36	3150	1210	3	-	6	M1-6			
16.00	106	15930	28	3290	1140	3	-	6	M1-6			
17.42	98	19470	32	3350	1230	3	-	6	M1-6			
19.45	87	20360	30	3440	1230	3	-	6	M1-6			
22.41	76	20360	26	3680	1250	3	-	6	M1-6			
24.92	68	22130	25	3680	1230	3	-	6	M1-6			
27.88	61	23010	23	3800	1230	3	-	6	M1-6			
31.39	54	23900	21	3930	1230	3	-	6	M2			
36.52	47	22130	17.1	4400	1440	3	-	6	M1-6			
44.02	39	23010	14.8	4700	1450	3	-	6	M2-6			
49.16	35	23900	13.7	4850	1450	3	-	5	M2,4,6			
56.64	30	23900	11.9	5160	1460	3	-	5	-			



Weight [lbs]	Stages		AD2	AD3	AD3	AD3
	Large	Small				
K87	3	-	206	215	229	262

K87: -27 lbs / KAF87: +2 lbs / KF87: +20 lbs

10.2.16 K87R57



K87R57 AD.. , n _e = 1700 rpm										23900 lb-in		
i [ratio]	n _a [rpm]	T _a max [lb-in]	P _e [HP]	F _{Ra} ¹⁾ [lb]	F _{Re} [lb]	Stages		φ (/R) [']				
						Lg	Sm					
141	12	23010	4.7	6160	290	3	2	-	-			
159	11	23900	4.4	6130	300	3	2	-	-			
183	9.3	23900	3.8	6130	310	3	2	-	-			
201	8.5	23900	3.5	6130	310	3	2	-	-			
236	7.2	23900	2.9	6130	320	3	2	-	-			
250	6.8	23900	2.8	6130	320	3	2	-	-			
294	5.8	23900	2.4	6130	350	3	2	-	-			
330	5.2	23900	2.1	6130	350	3	2	-	-			
373	4.6	23900	1.9	6130	350	3	2	-	-			
426	4.0	23900	1.6	6130	350	3	2	-	-			
474	3.6	23900	1.5	6130	330	3	2	-	-			
562	3.0	23900	1.2	6130	350	3	2	-	-			
638	2.7	23900	1.1	6130	360	3	2	-	-			
726	2.3	23900	0.96	6130	370	3	2	-	-			
837	2.0	23900	0.83	6130	380	3	2	-	-			
951	1.8	23900	0.73	6130	380	3	2	-	-			
1078	1.6	23900	0.64	6130	380	3	2	-	-			
1229	1.4	23900	0.57	6130	380	3	2	-	-			
1415	1.2	23900	0.49	6130	380	3	2	-	-			
1657	1.0	23900	0.42	6130	380	3	2	-	-			
1854	0.92	23900	0.38	6130	380	3	2	-	-			
2088	0.81	23900	0.33	6130	390	3	2	-	-			
2371	0.72	23900	0.30	6130	390	3	3	-	-			
2728	0.62	23900	0.26	6130	390	3	3	-	-			
3107	0.55	23900	0.23	6130	390	3	3	-	-			
3609	0.47	23900	0.20	6130	390	3	3	-	-			
4037	0.42	23900	0.17	6130	390	3	3	-	-			
4562	0.37	23900	0.15	6130	400	3	3	-	-			
5240	0.32	23900	0.13	6130	400	3	3	-	-			
5930	0.29	23900	0.12	6130	400	3	3	-	-			
6832	0.25	23900	0.10	6130	400	3	3	-	-			
7854	0.22	23900	0.09	6130	400	3	3	-	-			
9073	0.19	23900	0.08	6130	400	3	3	-	-			
10217	0.17	23900	0.07	6130	400	3	3	-	-			
11737	0.14	23900	0.06	6130	400	3	3	-	-			
13168	0.13	23900	0.05	6130	400	3	3	-	-			
14829	0.11	23900	0.05	6130	400	3	3	-	-			
141	12	23010	4.7	6160	510	3	2	-	-			
159	11	23900	4.4	6130	520	3	2	-	-			
183	9.3	23900	3.8	6130	520	3	2	-	-			
201	8.5	23900	3.5	6130	520	3	2	-	-			
236	7.2	23900	2.9	6130	530	3	2	-	-			
250	6.8	23900	2.8	6130	530	3	2	-	-			
294	5.8	23900	2.4	6130	560	3	2	-	-			
330	5.2	23900	2.1	6130	560	3	2	-	-			
373	4.6	23900	1.9	6130	560	3	2	-	-			
426	4.0	23900	1.6	6130	570	3	2	-	-			
474	3.6	23900	1.5	6130	570	3	2	-	-			
562	3.0	23900	1.2	6130	580	3	2	-	-			
638	2.7	23900	1.1	6130	580	3	2	-	-			
726	2.3	23900	0.96	6130	580	3	2	-	-			
837	2.0	23900	0.83	6130	590	3	2	-	-			
951	1.8	23900	0.73	6130	590	3	2	-	-			
1078	1.6	23900	0.64	6130	590	3	2	-	-			
12371	0.72	23900	0.30	6130	600	3	3	-	-			
2728	0.62	23900	0.26	6130	600	3	3	-	-			
3609	0.47	23900	0.20	6130	600	3	3	-	-			
4037	0.42	23900	0.17	6130	610	3	3	-	-			
4562	0.37	23900	0.15	6130	610	3	3	-	-			
5240	0.32	23900	0.13	6130	610	3	3	-	-			
Weight [lbs]	Stages		AD2		AD3							
	Large	Small										
K87R57	3	2	257		264							
	3	3	259		266							
KA87: -27 lbs / KAF87: +2 lbs / KF87: +20 lbs												

10.2.17 K97

K97 AD.. , n _e = 1700 rpm										38060 lb-in				
i [ratio]	n _a [rpm]	T _{a max} [lb-in]	P _e [HP]	F _{Ra} ¹⁾ [lb]	F _{Re} [lb]	Stages		φ (/R) [']						
						Lg	Sm							
62.55	27	37520	16.9	7020	290	3	-	7	M2,4,6	K97	AD3			
70.54	24	38060	15.2	7350	300	3	-	7	-					
77.89	22	38060	13.8	7680	310	3	-	7	-					
86.52	20	38060	12.4	8030	320	3	-	7	-					
96.80	18	38060	11.1	8420	330	3	-	7	-					
105.13	16	38060	10.2	8720	330	3	-	7	-					
123.93	14	38060	8.7	8990	340	3	-	7	-					
140.28	12	38060	7.7	8990	350	3	-	7	-					
153.21	11	38060	7.0	8990	350	3	-	7	-					
176.05	9.7	38060	6.1	8990	360	3	-	7	-					
41.87	41	38060	26	5800	670	3	-	7	M1-6	K97	AD4			
47.93	35	38060	22	6180	690	3	-	7	M1-6					
56.55	30	38060	19.0	6670	710	3	-	7	M1-6					
62.55	27	38060	17.2	6970	720	3	-	7	M2-6					
70.54	24	38060	15.2	7350	730	3	-	7	-					
77.89	22	38060	13.8	7680	740	3	-	7	-					
86.52	20	38060	12.4	8030	740	3	-	7	-					
96.80	18	38060	11.1	8420	750	3	-	7	-					
105.13	16	38060	10.2	8720	760	3	-	7	-					
123.93	14	38060	8.7	8990	770	3	-	7	-					
16.56	103	38060	65	3580	910	3	-	8	M1-6	K97	AD5			
18.96	90	38060	57	3870	940	3	-	8	M1-6					
22.37	76	38060	48	4230	990	3	-	8	M1-6					
24.75	69	38060	43	4470	1010	3	-	8	M1-6					
27.91	61	38060	38	4750	1030	3	-	8	M1-6					
30.82	55	38060	35	5000	1050	3	-	7	M1-6					
34.23	50	38060	31	5270	1060	3	-	7	M1-6					
38.30	44	38060	28	5560	1080	3	-	7	M2					
41.87	41	38060	26	5800	1350	3	-	7	M1-6					
47.93	35	38060	22	6180	1360	3	-	7	M1-6					
56.55	30	38060	19.0	6670	1380	3	-	7	M1-6					
62.55	27	38060	17.2	6970	1390	3	-	7	M2-6					
70.54	24	38060	15.2	7350	1400	3	-	7	-					
77.89	22	38060	13.8	7680	1410	3	-	7	-					
86.52	20	38060	12.4	8030	1410	3	-	7	-					
96.80	18	38060	11.1	8420	1420	3	-	7	-					
7.54	225	21240	80	3210	1500	3	-	10	M1-6			K97	AD6	
8.71	195	23540	76	3210	1480	3	-	10	M1-6					
10.41	163	25400	69	3320	1490	3	-	10	M1-6					
11.99	142	34430	81	3260	1490	3	-	8	M1-6					
13.85	123	38060	78	3220	1470	3	-	8	M1-6					
16.56	103	38060	65	3580	1530	3	-	8	M1-6					
18.96	90	38060	57	3870	1560	3	-	8	M1-6					
22.37	76	38060	48	4230	1600	3	-	8	M1-6					
24.75	69	38060	43	4470	1620	3	-	8	M1-6					
27.91	61	38060	38	4750	1640	3	-	8	M1-6					
30.82	55	38060	35	5000	1660	3	-	7	M1-6					
41.87	41	38060	26	5800	1940	3	-	7	M1-6					
47.93	35	38060	22	6180	1960	3	-	7	M1-6					
56.55	30	38060	19.0	6670	1970	3	-	7	M1-6					
62.55	27	38060	17.2	6970	1980	3	-	7	M2,4,6					
70.54	24	38060	15.2	7350	1990	3	-	7	-					
77.89	22	38060	13.8	7680	2000	3	-	7	-					
Weight [lbs]			Stages		AD3	AD4	AD5	AD6						
			Large	Small										
K97			3	-	347	359	395	425						
KA97: -40 lbs / KAF97: +15 lbs / KF97: +44 lbs														

10.2.18 K97R57



K97R57 AD.. , n_e = 1700 rpm 38060 lb-in

i [ratio]	n _a [rpm]	T _a max [lb-in]	P _e [HP]	F _{Ra} ¹⁾ [lb]	F _{Re} [lb]	Stages		φ _(/R) [']			
						Lg	Sm				
199	8.5	38060	5.6	8990	260	3	2	-	-		
232	7.3	38060	4.8	8990	270	3	2	-	-		
258	6.6	38060	4.3	8990	280	3	2	-	-		
305	5.6	38060	3.6	8990	290	3	2	-	-		
342	5.0	38060	3.2	8990	330	3	2	-	-		
382	4.5	38060	2.9	8990	320	3	2	-	-		
437	3.9	38060	2.5	8990	340	3	2	-	-		
504	3.4	38060	2.2	8990	350	3	2	-	-		
573	3.0	38060	1.9	8990	330	3	2	-	-		
652	2.6	38060	1.7	8990	350	3	2	-	-		
743	2.3	38060	1.5	8990	340	3	2	-	-		
855	2.0	38060	1.3	8990	270	3	2	-	-		
957	1.8	38060	1.2	8990	300	3	2	-	-		
1102	1.5	38060	1.0	8990	310	3	2	-	-		
1261	1.3	38060	0.88	8990	340	3	2	-	-		
1430	1.2	38060	0.77	8990	380	3	2	-	-		
1625	1.0	38060	0.68	8990	380	3	2	-	-		
1856	0.92	38060	0.60	8990	370	3	2	-	-		
2123	0.80	38060	0.52	8990	380	3	2	-	-	K97R57 AD2	
2419	0.70	38060	0.46	8990	380	3	2	-	-		
2757	0.62	38060	0.41	8990	390	3	3	-	-		
3108	0.55	38060	0.36	8990	390	3	3	-	-		
3583	0.47	38060	0.31	8990	390	3	3	-	-		
4082	0.42	38060	0.28	8990	390	3	3	-	-		
4669	0.36	38060	0.24	8990	390	3	3	-	-		
5391	0.32	38060	0.21	8990	390	3	3	-	-		
6027	0.28	38060	0.19	8990	390	3	3	-	-		
6970	0.24	38060	0.16	8990	400	3	3	-	-		
8054	0.21	38060	0.14	8990	390	3	3	-	-		
9083	0.19	38060	0.12	8990	400	3	3	-	-		
10317	0.16	38060	0.11	8990	400	3	3	-	-		
11677	0.15	38060	0.10	8990	400	3	3	-	-		
13182	0.13	38060	0.09	8990	400	3	3	-	-		
14897	0.11	38060	0.08	8990	400	3	3	-	-		
16666	0.10	38060	0.07	8990	400	3	3	-	-		
18091	0.09	38060	0.06	8990	400	3	3	-	-		
199	8.5	38060	5.6	8990	480	3	2	-	-		
232	7.3	38060	4.8	8990	480	3	2	-	-		
258	6.6	38060	4.3	8990	490	3	2	-	-		
305	5.6	38060	3.6	8990	510	3	2	-	-		
342	5.0	38060	3.2	8990	550	3	2	-	-		
382	4.5	38060	2.9	8990	530	3	2	-	-		
437	3.9	38060	2.5	8990	560	3	2	-	-		
504	3.4	38060	2.2	8990	560	3	2	-	-		
573	3.0	38060	1.9	8990	550	3	2	-	-		
652	2.6	38060	1.7	8990	560	3	2	-	-		
743	2.3	38060	1.5	8990	570	3	2	-	-		
1430	1.2	38060	0.77	8990	590	3	2	-	-	K97R57 AD3	
1625	1.0	38060	0.68	8990	590	3	2	-	-		
2123	0.80	38060	0.52	8990	590	3	2	-	-		
2757	0.62	38060	0.41	8990	600	3	3	-	-		
3583	0.47	38060	0.31	8990	600	3	3	-	-		
4082	0.42	38060	0.28	8990	600	3	3	-	-		
4669	0.36	38060	0.24	8990	600	3	3	-	-		
6027	0.28	38060	0.19	8990	610	3	3	-	-		
6970	0.24	38060	0.16	8990	610	3	3	-	-		
10317	0.16	38060	0.11	8990	610	3	3	-	-		

Weight [lbs]	Stages		AD2	AD3
	Large	Small		
K97R57	3	2	391	398
	3	3	393	400

KA97: -40 lbs / KAF97: +15 lbs / KF97: +44 lbs



10.2.19 K107

K107 AD.. , n _e = 1700 rpm										70800 lb-in		
i [ratio]	n _a [rpm]	T _{a max} [lb-in]	P _e [HP]	F _{Ra} ¹⁾ [lb]	F _{Re} [lb]	Stages		φ (/R) [']				
						Lg	Sm					
49.90	34	69380	39	7850	490	3	-	6	M1-6	K107	AD4	
57.17	30	70800	35	8360	510	3	-	6	M1-6			
66.52	26	70800	30	9160	530	3	-	6	M1-6			
73.30	23	70800	27	9680	550	3	-	6	M2,4,6			
82.61	21	70800	24	10340	560	3	-	6	-			
90.96	19	70800	22	10890	570	3	-	6	-			
100.75	17	70800	19.8	11480	590	3	-	6	-			
112.41	15	70800	17.8	12130	600	3	-	6	-			
121.46	14	70800	16.5	12600	610	3	-	6	-			
143.47	12	70800	13.9	13650	630	3	-	6	-			
31.28	54	60180	54	6840	1150	3	-	6	M1-6	K107	AD5	
32.69	52	63720	55	6570	560	3	-	6	M1-6			
37.00	46	63720	49	7140	1150	3	-	6	M1-6			
42.33	40	65140	43	7580	1170	3	-	6	M1-6			
49.90	34	69380	39	7850	1170	3	-	6	M1-6			
57.17	30	70800	35	8360	1190	3	-	6	M1-6			
66.52	26	70800	30	9160	1210	3	-	6	M1-6			
73.30	23	70800	27	9680	1220	3	-	6	M2,4,6			
82.61	21	70800	24	10340	1240	3	-	6	-			
90.96	19	70800	22	10890	1250	3	-	6	-			
100.75	17	70800	19.8	11480	1270	3	-	6	-			
112.41	15	70800	17.8	12130	1270	3	-	6	-			
7.35	231	23540	90	5730	1460	3	-	9	M1-6	K107	AD6	
8.69	196	27880	91	5760	1380	3	-	9	M1-6			
9.94	171	31950	91	5740	1310	3	-	9	M1-6			
11.73	145	37700	91	5670	1100	3	-	9	M1-6			
13.43	127	38060	80	6010	1180	3	-	9	M1-6			
14.64	116	46990	91	5560	1380	3	-	7	M1-6			
16.75	101	53810	91	5160	1310	3	-	7	M1-6			
19.74	86	63450	91	4440	1100	3	-	6	M1-6			
22.62	75	63720	80	4970	1190	3	-	6	M1-6			
26.32	65	63720	68	5620	1300	3	-	6	M1-6			
29.00	59	63720	62	6040	1340	3	-	6	M1-6			
31.28	54	60180	54	6840	1760	3	-	6	M1-6			
32.69	52	63720	55	6570	1360	3	-	6	M1-6			
37.00	46	63720	49	7140	1760	3	-	6	M1-6			
42.33	40	65140	43	7580	1780	3	-	6	M1-6			
49.90	34	69380	39	7850	1780	3	-	6	M1-6			
57.17	30	70800	35	8360	1790	3	-	6	M1-6			
66.52	26	70800	30	9160	1820	3	-	6	M1-6			
73.30	23	70800	27	9680	1830	3	-	6	M2,4,6			
82.61	21	70800	24	10340	1840	3	-	6	-			
90.96	19	70800	22	10890	1850	3	-	6	-			
Weight [lbs]		Stages		AD4		AD5		AD6				
		Large	Small									
K107		3	-	614		643		674				
KA107: -60 lbs / KAF107: +7 lbs / KF107: +27 lbs												

10 K - Helical Bevel

K.. AD

10.2.20 K107R77

K107R77 AD.. , n _e = 1700 rpm										70800 lb-in		
i [ratio]	n _a [rpm]	T _{a max} [lb-in]	P _e [HP]	F _{RA} ¹⁾ [lb]	F _{Re} [lb]	Stages		φ _(/R) [']				
						Lg	Sm					
196	8.7	64160	9.5	14610	210	3	2	-	-			
222	7.7	69740	9.1	14610	210	3	2	-	-			
251	6.8	70800	8.2	14610	220	3	2	-	-			
286	5.9	70800	7.2	14610	230	3	2	-	-			
318	5.3	70800	6.5	14610	230	3	2	-	-			
364	4.7	70800	5.7	14610	250	3	2	-	-			
408	4.2	70800	5.0	14610	300	3	2	-	-			
461	3.7	70800	4.5	14610	310	3	2	-	-			
522	3.3	70800	3.9	14610	310	3	2	-	-			
615	2.8	70800	3.3	14610	330	3	2	-	-			
696	2.4	70800	3.0	14610	310	3	2	-	-			
793	2.1	70800	2.6	14610	320	3	2	-	-			
904	1.9	70800	2.3	14610	350	3	2	-	-			
1030	1.7	70800	2.0	14610	350	3	2	-	-			
1166	1.5	70800	1.8	14610	340	3	2	-	-			
1336	1.3	70800	1.5	14610	280	3	2	-	-			
1554	1.1	70800	1.3	14610	310	3	2	-	-			
1713	0.99	70800	1.2	14610	330	3	2	-	-			
1939	0.88	70800	1.1	14610	370	3	3	-	-			
2286	0.74	70800	0.91	14610	370	3	3	-	-			
2599	0.65	70800	0.80	14610	380	3	3	-	-			
2977	0.57	70800	0.70	14610	380	3	3	-	-			
3358	0.51	70800	0.62	14610	380	3	3	-	-			
3810	0.45	70800	0.55	14610	380	3	3	-	-			
4359	0.39	70800	0.48	14610	380	3	3	-	-			
5138	0.33	70800	0.41	14610	390	3	3	-	-			
5662	0.30	70800	0.37	14610	390	3	3	-	-			
6184	0.27	70800	0.34	14610	390	3	3	-	-			
7270	0.23	70800	0.29	14610	390	3	3	-	-			
8328	0.20	70800	0.25	14610	390	3	3	-	-			
9524	0.18	70800	0.22	14610	390	3	3	-	-			
10677	0.16	70800	0.20	14610	390	3	3	-	-			
12211	0.14	70800	0.17	14610	390	3	3	-	-			
14311	0.12	70800	0.15	14610	390	3	3	-	-			
140	12	63720	13.2	14090	370	3	2	-	-			
154	11	63720	12.0	14610	390	3	2	-	-			
174	9.8	63720	10.7	14610	400	3	2	-	-			
196	8.7	70800	10.5	14610	410	3	2	-	-			
222	7.7	70800	9.3	14610	430	3	2	-	-			
251	6.8	70800	8.2	14610	430	3	2	-	-			
286	5.9	70800	7.2	14610	440	3	2	-	-			
318	5.3	70800	6.5	14610	450	3	2	-	-			
364	4.7	70800	5.7	14610	470	3	2	-	-			
408	4.2	70800	5.0	14610	520	3	2	-	-			
461	3.7	70800	4.5	14610	520	3	2	-	-			
522	3.3	70800	3.9	14610	530	3	2	-	-			
615	2.8	70800	3.3	14610	540	3	2	-	-			
696	2.4	70800	3.0	14610	530	3	2	-	-			
793	2.1	70800	2.6	14610	530	3	2	-	-			
904	1.9	70800	2.3	14610	560	3	2	-	-			
1030	1.7	70800	2.0	14610	570	3	2	-	-			
1166	1.5	70800	1.8	14610	550	3	2	-	-			
1336	1.3	70800	1.5	14610	560	3	2	-	-			
1554	1.1	70800	1.3	14610	570	3	2	-	-			
1713	0.99	70800	1.2	14610	570	3	2	-	-			
1939	0.88	70800	1.1	14610	580	3	3	-	-			
2286	0.74	70800	0.91	14610	590	3	3	-	-			
2599	0.65	70800	0.80	14610	590	3	3	-	-			



K107R77

AD2

K107R77

AD3

K107R77 AD.. , n_e = 1700 rpm 70800 lb-in

i [ratio]	n _a [rpm]	T _a max [lb-in]	P _e [HP]	F _{Ra} ¹⁾ [lb]	F _{Re} [lb]	Stages		φ _(/R) [']		
						Lg	Sm			
2977	0.57	70800	0.70	14610	590	3	3	-	-	K107R77 AD3
3358	0.51	70800	0.62	14610	600	3	3	-	-	
3810	0.45	70800	0.55	14610	590	3	3	-	-	
4359	0.39	70800	0.48	14610	600	3	3	-	-	
5138	0.33	70800	0.41	14610	600	3	3	-	-	
5662	0.30	70800	0.37	14610	600	3	3	-	-	
6184	0.27	70800	0.34	14610	600	3	3	-	-	
140	12	63720	13.2	14090	770	3	2	-	-	K107R77 AD4
154	11	63720	12.0	14610	790	3	2	-	-	
174	9.8	63720	10.7	14610	800	3	2	-	-	
196	8.7	70800	10.5	14610	820	3	2	-	-	
222	7.7	70800	9.3	14610	820	3	2	-	-	
251	6.8	70800	8.2	14610	830	3	2	-	-	
286	5.9	70800	7.2	14610	840	3	2	-	-	
318	5.3	70800	6.5	14610	850	3	2	-	-	
364	4.7	70800	5.7	14610	870	3	2	-	-	
408	4.2	70800	5.0	14610	900	3	2	-	-	
461	3.7	70800	4.5	14610	910	3	2	-	-	
522	3.3	70800	3.9	14610	910	3	2	-	-	
615	2.8	70800	3.3	14610	920	3	2	-	-	
696	2.4	70800	3.0	14610	920	3	2	-	-	
904	1.9	70800	2.3	14610	940	3	2	-	-	
1030	1.7	70800	2.0	14610	950	3	2	-	-	
1939	0.88	70800	1.1	14610	960	3	3	-	-	
2286	0.74	70800	0.91	14610	970	3	3	-	-	
3358	0.51	70800	0.62	14610	970	3	3	-	-	
5138	0.33	70800	0.41	14610	980	3	3	-	-	
5662	0.30	70800	0.37	14610	980	3	3	-	-	



Weight [lbs]	Stages		AD2	AD3	AD4
	Large	Small			
K107R77	3	2	675	682	696
	3	3	678	685	698

KA107: -60 lbs / KAF107: +7 lbs / KF107: +27 lbs

10 K - Helical Bevel

K.. AD



10.2.21 K127

K127 AD.. , n _e = 1700 rpm										115050 lb-in			
i [ratio]	n _a [rpm]	T _{a max} [lb-in]	P _e [HP]	F _{Ra} ¹⁾ [lb]	F _{Re} [lb]	Stages		φ (/R) [']					
						Lg	Sm						
110.18	15	115050	29	16940	350	3	-	5	-	K127	AD4		
122.48	14	115050	27	17730	380	3	-	5	-				
136.14	12	115050	24	17800	400	3	-	5	-				
146.07	12	115050	22	17800	420	3	-	5	-				
47.82	36	115050	68	11570	960	3	-	5	M1-6	K127	AD5		
54.07	31	115050	60	12280	1000	3	-	5	M1-6				
62.60	27	115050	52	13160	1030	3	-	5	M1-6				
70.95	24	115050	46	13940	1050	3	-	5	M1-6				
81.98	21	115050	40	14880	1080	3	-	5	M1-6				
89.89	19	115050	36	15510	1090	3	-	5	M2,4,6				
110.18	15	115050	29	16940	1130	3	-	5	-				
122.48	14	115050	27	17730	1150	3	-	5	-				
136.14	12	115050	24	17800	1160	3	-	5	-				
40.19	42	115050	81	10610	1540	3	-	5	M1-6			K127	AD6
47.82	36	115050	68	11570	1590	3	-	5	M1-6				
54.07	31	115050	60	12280	1620	3	-	5	M1-6				
62.60	27	115050	52	13160	1650	3	-	5	M1-6				
70.95	24	115050	46	13940	1670	3	-	5	M1-6				
81.98	21	115050	40	14880	1690	3	-	5	M1-6				
89.89	19	115050	36	15510	1700	3	-	5	M2,4,6				
110.18	15	115050	29	16940	1740	3	-	5	-				
23.91	71	115050	136	7940	1440	3	-	6	M1-6	K127	AD7		
27.68	61	115050	117	8710	1700	3	-	6	M1-6				
31.37	54	115050	104	9320	1880	3	-	6	M1-6				
36.25	47	115050	90	10060	2100	3	-	6	M1-6				
40.19	42	115050	81	10610	3670	3	-	5	M1-6				
47.82	36	115050	68	11570	3710	3	-	5	M1-6				
54.07	31	115050	60	12280	3740	3	-	5	M1-6				
62.60	27	115050	52	13160	3760	3	-	5	M1-6				
70.95	24	115050	46	13940	3780	3	-	5	M1-6				
81.98	21	115050	40	14880	3810	3	-	5	M1-6				
89.89	19	115050	36	15510	3820	3	-	5	M2,4,6				
8.68	196	63990	208	6640	5010	3	-	8	M1-6			K127	AD8
10.74	158	70800	186	6890	5010	3	-	8	M1-6				
12.79	133	75490	167	7190	5030	3	-	8	M1-6				
14.35	118	107090	211	5880	5000	3	-	6	M1-6				
17.77	96	115050	183	6170	5040	3	-	6	M1-6				
21.15	80	115050	154	7200	5130	3	-	6	M1-6				
23.91	71	115050	136	7940	5190	3	-	6	M1-6				
27.68	61	115050	117	8710	5250	3	-	6	M1-6				
31.37	54	115050	104	9320	5290	3	-	6	M1-6				
40.19	42	115050	81	10610	5780	3	-	5	M1-6				
47.82	36	115050	68	11570	5830	3	-	5	M1-6				
54.07	31	115050	60	12280	5850	3	-	5	M1-6				
62.60	27	115050	52	13160	5880	3	-	5	M1-6				
70.95	24	115050	46	13940	5900	3	-	5	M1-6				

Weight [lbs]	Stages		AD4	AD5	AD6	AD7	AD8
	Large	Small					
K127	3	-	963	989	1015	1014	1062

KA127: -62 lbs / KAF127: +20 lbs / KF127: +93 lbs

10.2.22 K127R77



K127R77 AD.. , n _e = 1700 rpm										115050 lb-in		
i [ratio]	n _a [rpm]	T _a max [lb-in]	P _e [HP]	F _{RA} ¹⁾ [lb]	F _{Re} [lb]	Stages		φ (°/R) [']				
						Lg	Sm					
418	4.1	115050	8.0	17800	210	3	2	-	-			
477	3.6	115050	7.0	17800	260	3	2	-	-			
549	3.1	115050	6.1	17800	250	3	2	-	-			
610	2.8	115050	5.5	17800	280	3	2	-	-			
704	2.4	115050	4.8	17800	280	3	2	-	-			
790	2.2	115050	4.2	17800	320	3	2	-	-			
899	1.9	115050	3.7	17800	290	3	2	-	-			
1025	1.7	115050	3.3	17800	300	3	2	-	-			
1177	1.4	115050	2.8	17800	320	3	2	-	-			
1342	1.3	115050	2.5	17800	320	3	2	-	-			
1541	1.1	115050	2.2	17800	340	3	2	-	-			
1757	0.97	115050	1.9	17800	340	3	2	-	-			
1926	0.88	115050	1.7	17800	350	3	2	-	-			
2268	0.75	115050	1.5	17800	370	3	3	-	-			
2607	0.65	115050	1.3	17800	370	3	3	-	-			
3009	0.56	115050	1.1	17800	370	3	3	-	-			K127R77 AD2
3311	0.51	115050	1.0	17800	380	3	3	-	-			
3889	0.44	115050	0.87	17800	380	3	3	-	-			
4423	0.38	115050	0.77	17800	380	3	3	-	-			
5027	0.34	115050	0.68	17800	380	3	3	-	-			
5804	0.29	115050	0.59	17800	380	3	3	-	-			
6565	0.26	115050	0.52	17800	380	3	3	-	-			
7482	0.23	115050	0.45	17800	380	3	3	-	-			
8443	0.20	115050	0.40	17800	390	3	3	-	-			
9819	0.17	115050	0.35	17800	390	3	3	-	-			
10915	0.16	115050	0.31	17800	390	3	3	-	-			
12440	0.14	115050	0.27	17800	390	3	3	-	-			
14975	0.11	115050	0.23	17800	390	3	3	-	-			
16006	0.11	115050	0.21	17800	390	3	3	-	-			
17550	0.10	115050	0.19	17800	390	3	3	-	-			
418	4.1	115050	8.0	17800	420	3	2	-	-			
477	3.6	115050	7.0	17800	480	3	2	-	-			
549	3.1	115050	6.1	17800	470	3	2	-	-			
610	2.8	115050	5.5	17800	490	3	2	-	-			
704	2.4	115050	4.8	17800	490	3	2	-	-			
790	2.2	115050	4.2	17800	530	3	2	-	-			
899	1.9	115050	3.7	17800	510	3	2	-	-			
1025	1.7	115050	3.3	17800	510	3	2	-	-			
1177	1.4	115050	2.8	17800	530	3	2	-	-			
1342	1.3	115050	2.5	17800	530	3	2	-	-			
1541	1.1	115050	2.2	17800	550	3	2	-	-			
1757	0.97	115050	1.9	17800	550	3	2	-	-			
1926	0.88	115050	1.7	17800	560	3	2	-	-			
2268	0.75	115050	1.5	17800	580	3	3	-	-			
2607	0.65	115050	1.3	17800	580	3	3	-	-			
3009	0.56	115050	1.1	17800	590	3	3	-	-			
3311	0.51	115050	1.0	17800	590	3	3	-	-			
3889	0.44	115050	0.87	17800	590	3	3	-	-			
4423	0.38	115050	0.77	17800	590	3	3	-	-			
5027	0.34	115050	0.68	17800	590	3	3	-	-			
5804	0.29	115050	0.59	17800	600	3	3	-	-			
6565	0.26	115050	0.52	17800	590	3	3	-	-			
8443	0.20	115050	0.40	17800	600	3	3	-	-			
10915	0.16	115050	0.31	17800	600	3	3	-	-			
418	4.1	115050	8.0	17800	820	3	2	-	-			
477	3.6	115050	7.0	17800	870	3	2	-	-			
549	3.1	115050	6.1	17800	860	3	2	-	-			K127R77 AD4

10 K - Helical Bevel

K.. AD

K127R77 AD.. , $n_e = 1700$ rpm



115050 lb-in

i [ratio]	n_a [rpm]	T_a max [lb-in]	P_e [HP]	$F_{Ra}^{1)}$ [lb]	F_{Re} [lb]	Stages		ϕ (/R) [']		
						Lg	Sm			
610	2.8	115050	5.5	17800	880	3	2	-	-	K127R77 AD4
704	2.4	115050	4.8	17800	890	3	2	-	-	
790	2.2	115050	4.2	17800	920	3	2	-	-	
899	1.9	115050	3.7	17800	900	3	2	-	-	
1177	1.4	115050	2.8	17800	920	3	2	-	-	
1541	1.1	115050	2.2	17800	930	3	2	-	-	
2268	0.75	115050	1.5	17800	960	3	3	-	-	
2607	0.65	115050	1.3	17800	960	3	3	-	-	
3009	0.56	115050	1.1	17800	960	3	3	-	-	
3311	0.51	115050	1.0	17800	970	3	3	-	-	
3889	0.44	115050	0.87	17800	970	3	3	-	-	
4423	0.38	115050	0.77	17800	970	3	3	-	-	
5804	0.29	115050	0.59	17800	970	3	3	-	-	

Weight [lbs]	Stages		AD1	AD2
	Large	Small		
K127R77	3	2	94	97
	3	3	95	97

KA127: -62 lbs / KAF127: +20 lbs / KF127: +93 lbs



10.2.23 K127R87

K127R87 AD.. , n _e = 1700 rpm										115050 lb-in	
i [ratio]	n _a [rpm]	T _a max [lb-in]	P _e [HP]	F _{Re} ¹⁾ [lb]	F _{Re} [lb]	Stages		φ _(/R) [']			
						Lg	Sm				
367	4.6	115050	9.1	17800	210	3	2	-	-		
418	4.1	115050	8.0	17800	260	3	2	-	-		K127R87 AD2
473	3.6	115050	7.1	17800	290	3	2	-	-		
536	3.2	115050	6.2	17800	290	3	2	-	-		
166	10	106200	18.6	17920	320	3	2	-	-		
200	8.5	106200	15.4	17920	350	3	2	-	-		K127R87 AD3
213	8.0	115050	15.7	17800	360	3	2	-	-		
253	6.7	115050	13.2	17800	400	3	2	-	-		
287	5.9	115050	11.7	17800	420	3	2	-	-		
330	5.2	115050	10.1	17800	400	3	2	-	-		
367	4.6	115050	9.1	17800	410	3	2	-	-		
418	4.1	115050	8.0	17800	450	3	2	-	-		
473	3.6	115050	7.1	17800	480	3	2	-	-		
536	3.2	115050	6.2	17800	480	3	2	-	-		
147	12	106200	21	17920	720	3	2	-	-		K127R87 AD4
166	10	106200	18.6	17920	750	3	2	-	-		
200	8.5	106200	15.4	17920	770	3	2	-	-		
213	8.0	115050	15.7	17800	790	3	2	-	-		
253	6.7	115050	13.2	17800	820	3	2	-	-		
287	5.9	115050	11.7	17800	840	3	2	-	-		
330	5.2	115050	10.1	17800	820	3	2	-	-		
367	4.6	115050	9.1	17800	830	3	2	-	-		
418	4.1	115050	8.0	17800	870	3	2	-	-		
473	3.6	115050	7.1	17800	900	3	2	-	-		
536	3.2	115050	6.2	17800	890	3	2	-	-		
147	12	106200	21	17920	1390	3	2	-	-		K127R87 AD5
166	10	106200	18.6	17920	1420	3	2	-	-		
200	8.5	106200	15.4	17920	1440	3	2	-	-		
213	8.0	115050	15.7	17800	1450	3	2	-	-		
253	6.7	115050	13.2	17800	1490	3	2	-	-		
287	5.9	115050	11.7	17800	1500	3	2	-	-		
330	5.2	115050	10.1	17800	1490	3	2	-	-		
367	4.6	115050	9.1	17800	1490	3	2	-	-		
418	4.1	115050	8.0	17800	1530	3	2	-	-		
Weight [lbs]		Stages		AD2		AD3		AD4		AD5	
		Large	Small								
K127R87		3	2	1074		1083		1097		1129	
KA127: -62 lbs / KAF127: +20 lbs / KF127: +93 lbs											

10 K - Helical Bevel

K.. AD



10.2.24 K157

K157 AD.. , n _e = 1700 rpm										159300 lb-in		
i [ratio]	n _a [rpm]	T _{a max} [lb-in]	P _e [HP]	F _{Ra} ⁽¹⁾ [lb]	F _{Re} [lb]	Stages		φ (/R) [']				
						Lg	Sm					
61.02	28	159300	74	16260	880	3	-	5	M1-6	K157	AD5	
70.38	24	159300	64	17360	910	3	-	5	M1-6			
79.75	21	159300	56	18360	940	3	-	5	M1-6			
91.65	19	159300	49	19520	970	3	-	5	M2			
100.22	17	159300	45	20290	990	3	-	5	-			
122.39	14	159300	37	22090	1030	3	-	5	-			
150.41	11	159300	30	24070	1060	3	-	5	-			
54.29	31	159300	83	15390	1470	3	-	5	M1-6	K157	AD6	
61.02	28	159300	74	16260	1500	3	-	5	M1-6			
70.38	24	159300	64	17360	1530	3	-	5	M1-6			
79.75	21	159300	56	18360	1560	3	-	5	M1-6			
91.65	19	159300	49	19520	1590	3	-	5	M2			
100.22	17	159300	45	20290	1600	3	-	5	-			
122.39	14	159300	37	22090	1640	3	-	5	-			
38.02	45	159300	118	12930	3500	3	-	5	M1-6	K157	AD7	
46.79	36	159300	96	14330	3580	3	-	5	M1-6			
54.29	31	159300	83	15390	3610	3	-	5	M1-6			
61.02	28	159300	74	16260	3640	3	-	5	M1-6			
70.38	24	159300	64	17360	3670	3	-	5	M1-6			
79.75	21	159300	56	18360	3690	3	-	5	M1-6			
91.65	19	159300	49	19520	3720	3	-	5	M2			
100.22	17	159300	45	20290	3730	3	-	5	-			
12.65	134	150450	336	7300	4420	3	-	6	M1-6	K157	AD8	
14.92	114	159300	301	7600	4470	3	-	6	M1-6			
18.37	93	159300	245	8660	4640	3	-	6	M1-6			
21.31	80	159300	211	9460	4720	3	-	6	M1-6			
23.95	71	159300	188	10110	4790	3	-	6	M1-6			
27.62	62	141600	145	11930	5030	3	-	6	M1-6			
31.30	54	156650	141	11850	4940	3	-	6	M1-6			
38.02	45	159300	118	12930	5620	3	-	5	M1-6			
46.79	36	159300	96	14330	5690	3	-	5	M1-6			
54.29	31	159300	83	15390	5730	3	-	5	M1-6			
61.02	28	159300	74	16260	5750	3	-	5	M1-6			
70.38	24	159300	64	17360	5780	3	-	5	M1-6			
79.75	21	159300	56	18360	5810	3	-	5	M1-6			

Weight [lbs]	Stages		AD5	AD6	AD7	AD8
	Large	Small				
K157	3	-	1508	1545	1532	1584

KA157: -81 lbs / KAF157: +48 lbs / KF157: +173 lbs

10.2.25 K157R97



K157R97 AD.. , n _e = 1700 rpm										159300 lb-in		
i [ratio]	n _a [rpm]	T _a max [lb-in]	P _e [HP]	F _{Ra} ¹⁾ [lb]	F _{Re} [lb]	Stages		φ (/R) [']				
						Lg	Sm					
291	5.8	159300	15.9	25220	370	3	2	-	-			
333	5.1	159300	13.9	25220	380	3	2	-	-			
379	4.5	159300	12.2	25220	420	3	2	-	-			
434	3.9	159300	10.7	25220	430	3	2	-	-			
504	3.4	159300	9.2	25220	430	3	2	-	-			
567	3.0	159300	8.2	25220	440	3	2	-	-			
661	2.6	159300	7.0	25220	490	3	2	-	-			
756	2.2	159300	6.1	25220	490	3	2	-	-			
854	2.0	159300	5.4	25220	480	3	2	-	-			
942	1.8	159300	4.9	25220	490	3	2	-	-			
1093	1.6	159300	4.2	25220	500	3	2	-	-			
1229	1.4	159300	3.8	25220	510	3	2	-	-			
1365	1.2	159300	3.4	25220	510	3	2	-	-			
1659	1.0	159300	2.8	25220	520	3	2	-	-			
1805	0.94	159300	2.6	25220	540	3	3	-	-		K157R97	AD3
2029	0.84	159300	2.3	25220	550	3	3	-	-			
2322	0.73	159300	2.0	25220	550	3	3	-	-			
2610	0.65	159300	1.8	25220	550	3	3	-	-			
3051	0.56	159300	1.5	25220	550	3	3	-	-			
3516	0.48	159300	1.3	25220	560	3	3	-	-			
3979	0.43	159300	1.2	25220	560	3	3	-	-			
4514	0.38	159300	1.0	25220	570	3	3	-	-			
5074	0.34	159300	0.93	25220	570	3	3	-	-			
5931	0.29	159300	0.79	25220	570	3	3	-	-			
6881	0.25	159300	0.68	25220	570	3	3	-	-			
7734	0.22	159300	0.61	25220	570	3	3	-	-			
8718	0.19	159300	0.54	25220	570	3	3	-	-			
10114	0.17	159300	0.47	25220	570	3	3	-	-			
11368	0.15	159300	0.41	25220	570	3	3	-	-			
291	5.8	159300	15.9	25220	790	3	2	-	-			
333	5.1	159300	13.9	25220	800	3	2	-	-			
379	4.5	159300	12.2	25220	840	3	2	-	-			
434	3.9	159300	10.7	25220	840	3	2	-	-			
504	3.4	159300	9.2	25220	840	3	2	-	-			
567	3.0	159300	8.2	25220	860	3	2	-	-			
661	2.6	159300	7.0	25220	900	3	2	-	-			
756	2.2	159300	6.1	25220	900	3	2	-	-			
854	2.0	159300	5.4	25220	890	3	2	-	-			
942	1.8	159300	4.9	25220	900	3	2	-	-			
1093	1.6	159300	4.2	25220	910	3	2	-	-			
1229	1.4	159300	3.8	25220	920	3	2	-	-			
1365	1.2	159300	3.4	25220	920	3	2	-	-			
1659	1.0	159300	2.8	25220	930	3	2	-	-			
1805	0.94	159300	2.6	25220	950	3	3	-	-		K157R97	AD4
2029	0.84	159300	2.3	25220	950	3	3	-	-			
2322	0.73	159300	2.0	25220	950	3	3	-	-			
2610	0.65	159300	1.8	25220	950	3	3	-	-			
3051	0.56	159300	1.5	25220	950	3	3	-	-			
3516	0.48	159300	1.3	25220	960	3	3	-	-			
3979	0.43	159300	1.2	25220	960	3	3	-	-			
4514	0.38	159300	1.0	25220	970	3	3	-	-			
5074	0.34	159300	0.93	25220	970	3	3	-	-			
5931	0.29	159300	0.79	25220	970	3	3	-	-			
6881	0.25	159300	0.68	25220	970	3	3	-	-			
7734	0.22	159300	0.61	25220	970	3	3	-	-			

10 K - Helical Bevel

K.. AD

K157R97 AD.. , $n_e = 1700$ rpm



159300 lb-in

i [ratio]	n_a [rpm]	T_a max [lb-in]	P_e [HP]	$F_{Ra}^{1)}$ [lb]	F_{Re} [lb]	Stages		ϕ (/R) [']		
						Lg	Sm			
291	5.8	159300	15.9	25220	1460	3	2	-	-	K157R97 AD5
333	5.1	159300	13.9	25220	1470	3	2	-	-	
379	4.5	159300	12.2	25220	1510	3	2	-	-	
434	3.9	159300	10.7	25220	1510	3	2	-	-	
504	3.4	159300	9.2	25220	1510	3	2	-	-	
567	3.0	159300	8.2	25220	1530	3	2	-	-	
661	2.6	159300	7.0	25220	1570	3	2	-	-	
756	2.2	159300	6.1	25220	1570	3	2	-	-	
854	2.0	159300	5.4	25220	1560	3	2	-	-	
942	1.8	159300	4.9	25220	1560	3	2	-	-	
1093	1.6	159300	4.2	25220	1570	3	2	-	-	
1229	1.4	159300	3.8	25220	1580	3	2	-	-	
1365	1.2	159300	3.4	25220	1580	3	2	-	-	
1805	0.94	159300	2.6	25220	1610	3	3	-	-	
2029	0.84	159300	2.3	25220	1620	3	3	-	-	
2322	0.73	159300	2.0	25220	1610	3	3	-	-	
2610	0.65	159300	1.8	25220	1620	3	3	-	-	
3516	0.48	159300	1.3	25220	1620	3	3	-	-	
4514	0.38	159300	1.0	25220	1630	3	3	-	-	
5074	0.34	159300	0.93	25220	1630	3	3	-	-	
291	5.8	159300	15.9	25220	2050	3	2	-	-	K157R97 AD6
333	5.1	159300	13.9	25220	2060	3	2	-	-	
379	4.5	159300	12.2	25220	2090	3	2	-	-	
434	3.9	159300	10.7	25220	2100	3	2	-	-	
504	3.4	159300	9.2	25220	2090	3	2	-	-	
567	3.0	159300	8.2	25220	2110	3	2	-	-	
661	2.6	159300	7.0	25220	2150	3	2	-	-	
756	2.2	159300	6.1	25220	2150	3	2	-	-	
854	2.0	159300	5.4	25220	2140	3	2	-	-	
942	1.8	159300	4.9	25220	2140	3	2	-	-	
1093	1.6	159300	4.2	25220	2150	3	2	-	-	
1229	1.4	159300	3.8	25220	2160	3	2	-	-	
1805	0.94	159300	2.6	25220	2190	3	3	-	-	
2029	0.84	159300	2.3	25220	2190	3	3	-	-	
2322	0.73	159300	2.0	25220	2190	3	3	-	-	
2610	0.65	159300	1.8	25220	2200	3	3	-	-	
3516	0.48	159300	1.3	25220	2200	3	3	-	-	
4514	0.38	159300	1.0	25220	2210	3	3	-	-	
5074	0.34	159300	0.93	25220	2210	3	3	-	-	

Weight [lbs]	Stages		AD3	AD4	AD5	AD6
	Large	Small				
K157R97	3	2	1733	1744	1781	1811
	3	3	1739	1751	1787	1817

KA157: -81 lbs / KAF157: +48 lbs / KF157: +173 lbs



10.2.26 K157R107

K157R107 AD.. , $n_e = 1700$ rpm										159300 lb-in	
i [ratio]	n_a [rpm]	$T_{a \max}$ [lb-in]	P_e [HP]	$F_{Ra}^{1)}$ [lb]	F_{Re} [lb]	Stages		ϕ (/R) [']			
						Lg	Sm				
253	6.7	159300	18.3	25220	360	3	2	-	-	K157R107	AD3
299	5.7	159300	15.5	25220	380	3	2	-	-		
385	4.4	159300	12.0	25220	450	3	2	-	-		
107	16	159300	43	20870	550	3	2	-	-	K157R107	AD4
122	14	159300	38	22090	580	3	2	-	-		
157	11	159300	30	24510	720	3	2	-	-		
187	9.1	159300	25	25220	760	3	2	-	-		
213	8.0	159300	22	25220	750	3	2	-	-		
230	7.4	159300	20	25220	800	3	2	-	-		
253	6.7	159300	18.3	25220	790	3	2	-	-		
299	5.7	159300	15.5	25220	800	3	2	-	-		
325	5.2	159300	14.3	25220	850	3	2	-	-		
385	4.4	159300	12.0	25220	860	3	2	-	-		
107	16	159300	43	20870	1240	3	2	-	-	K157R107	AD5
122	14	159300	38	22090	1260	3	2	-	-		
157	11	159300	30	24510	1390	3	2	-	-		
187	9.1	159300	25	25220	1430	3	2	-	-		
213	8.0	159300	22	25220	1420	3	2	-	-		
230	7.4	159300	20	25220	1470	3	2	-	-		
253	6.7	159300	18.3	25220	1460	3	2	-	-		
299	5.7	159300	15.5	25220	1470	3	2	-	-		
325	5.2	159300	14.3	25220	1520	3	2	-	-		
385	4.4	159300	12.0	25220	1530	3	2	-	-		
107	16	159300	43	20870	1840	3	2	-	-	K157R107	AD6
122	14	159300	38	22090	1860	3	2	-	-		
157	11	159300	30	24510	1980	3	2	-	-		
187	9.1	159300	25	25220	2020	3	2	-	-		
213	8.0	159300	22	25220	2010	3	2	-	-		
230	7.4	159300	20	25220	2060	3	2	-	-		
253	6.7	159300	18.3	25220	2040	3	2	-	-		
299	5.7	159300	15.5	25220	2060	3	2	-	-		
325	5.2	159300	14.3	25220	2110	3	2	-	-		
385	4.4	159300	12.0	25220	2110	3	2	-	-		
Weight [lbs]		Stages		AD3	AD4	AD5	AD6				
		Large	Small								
K157R107		3	2	1837	1851	1881	1911				
KA157: -81 lbs / KAF157: +48 lbs / KF157: +173 lbs											

10 K - Helical Bevel

K.. AD



10.2.27 K167

K167 AD.. , n _e = 1700 rpm										283200 lb-in		
i [ratio]	n _a [rpm]	T _{a max} [lb-in]	P _e [HP]	F _{Ra} ¹⁾ [lb]	F _{Re} [lb]	Stages		φ (°/R) [']				
						Lg	Sm					
134.99	13	253110	53	33720	470	3	-	5	-			
164.50	10	261080	45	33720	460	3	-	4	-			K167 AD5
87.86	19	281430	90	30550	840	3	-	5	M1-6			
109.83	15	283200	73	33490	950	3	-	5	-			K167 AD6
134.99	13	283200	59	33720	1050	3	-	5	-			
60.74	28	283200	132	25890	2010	3	-	5	M1-6			
68.07	25	283200	117	27260	2190	3	-	5	M1-6			
78.14	22	283200	102	28960	2380	3	-	5	M1-6			K167 AD7
87.86	19	283200	91	30470	2500	3	-	5	M1-6			
109.83	15	283200	73	33490	2750	3	-	5	-			
17.34	98	248690	405	15250	3920	3	-	5	M1-6			
20.32	84	274350	381	15370	3850	3	-	5	M1-6			
24.52	69	283200	326	16590	3960	3	-	5	M1-6			
28.77	59	222140	218	20890	4590	3	-	5	M1-6			
32.25	53	248690	218	20740	4450	3	-	5	M1-6			
36.61	46	283200	218	20390	5040	3	-	5	M1-6			
42.89	40	283200	186	22020	5130	3	-	5	M1-6			
51.77	33	283200	154	24070	5220	3	-	5	M1-6			
60.74	28	283200	132	25890	5290	3	-	5	M1-6			
68.07	25	283200	117	27260	5330	3	-	5	M1-6			
78.14	22	283200	102	28960	5380	3	-	5	M1-6			
87.86	19	283200	91	30470	5400	3	-	5	M1-6			

Weight [lbs]	Stages		AD5	AD6	AD7	AD8
	Large	Small				
K167	3	-	2377	2414	2401	2453

KH167: -84 lbs

10.2.28 K167R97

K167R97 AD.. , n _e = 1700 rpm										283200 lb-in		
i [ratio]	n _a [rpm]	T _{a max} [lb-in]	P _e [HP]	F _{Re} ¹⁾ [lb]	F _{Re} [lb]	Stages		φ (°/R) [']				
						Lg	Sm					
561	3.0	283200	14.7	33720	380	3	2	-	-			
632	2.7	283200	13.0	33720	360	3	2	-	-			
757	2.2	283200	10.9	33720	410	3	2	-	-			
843	2.0	283200	9.8	33720	440	3	2	-	-			
944	1.8	283200	8.7	33720	420	3	2	-	-			
1101	1.5	283200	7.5	33720	460	3	2	-	-			
1296	1.3	283200	6.4	33720	440	3	2	-	-			
1408	1.2	283200	5.9	33720	440	3	2	-	-			
1704	1.0	283200	4.8	33720	470	3	2	-	-			
2182	0.78	283200	3.8	33720	480	3	2	-	-			
2263	0.75	283200	3.7	33720	530	3	3	-	-			
2755	0.62	283200	3.0	33720	520	3	3	-	-			
3376	0.50	283200	2.5	33720	530	3	3	-	-			
4079	0.42	283200	2.1	33720	540	3	3	-	-			
4788	0.36	283200	1.7	33720	550	3	3	-	-			
5355	0.32	283200	1.6	33720	550	3	3	-	-			
6562	0.26	283200	1.3	33720	550	3	3	-	-			
8628	0.20	283200	0.97	33720	560	3	3	-	-			
10264	0.17	283200	0.81	33720	560	3	3	-	-			
11573	0.15	283200	0.72	33720	560	3	3	-	-			
369	4.6	283200	22	33720	690	3	2	-	-			
423	4.0	283200	19.5	33720	750	3	2	-	-			
481	3.5	283200	17.1	33720	720	3	2	-	-			
561	3.0	283200	14.7	33720	810	3	2	-	-			
632	2.7	283200	13.0	33720	790	3	2	-	-			
757	2.2	283200	10.9	33720	830	3	2	-	-			
843	2.0	283200	9.8	33720	860	3	2	-	-			
944	1.8	283200	8.7	33720	840	3	2	-	-			
1101	1.5	283200	7.5	33720	870	3	2	-	-			
1296	1.3	283200	6.4	33720	850	3	2	-	-			
1408	1.2	283200	5.9	33720	860	3	2	-	-			
1704	1.0	283200	4.8	33720	880	3	2	-	-			
2182	0.78	283200	3.8	33720	890	3	2	-	-			
2263	0.75	283200	3.7	33720	930	3	3	-	-			
2755	0.62	283200	3.0	33720	930	3	3	-	-			
3376	0.50	283200	2.5	33720	930	3	3	-	-			
4079	0.42	283200	2.1	33720	940	3	3	-	-			
4788	0.36	283200	1.7	33720	950	3	3	-	-			
5355	0.32	283200	1.6	33720	960	3	3	-	-			
6562	0.26	283200	1.3	33720	960	3	3	-	-			
8628	0.20	283200	0.97	33720	970	3	3	-	-			
10264	0.17	283200	0.81	33720	970	3	3	-	-			
369	4.6	283200	22	33720	1370	3	2	-	-			
423	4.0	283200	19.5	33720	1420	3	2	-	-			
481	3.5	283200	17.1	33720	1390	3	2	-	-			
561	3.0	283200	14.7	33720	1480	3	2	-	-			
632	2.7	283200	13.0	33720	1450	3	2	-	-			
757	2.2	283200	10.9	33720	1500	3	2	-	-			
843	2.0	283200	9.8	33720	1520	3	2	-	-			
944	1.8	283200	8.7	33720	1510	3	2	-	-			
1101	1.5	283200	7.5	33720	1540	3	2	-	-			
1296	1.3	283200	6.4	33720	1520	3	2	-	-			
1704	1.0	283200	4.8	33720	1550	3	2	-	-			
2263	0.75	283200	3.7	33720	1600	3	3	-	-			
2755	0.62	283200	3.0	33720	1590	3	3	-	-			
4079	0.42	283200	2.1	33720	1610	3	3	-	-			
4788	0.36	283200	1.7	33720	1620	3	3	-	-			
5355	0.32	283200	1.6	33720	1620	3	3	-	-			



10

10 K - Helical Bevel

K.. AD



K167R97 AD.. , $n_e = 1700$ rpm

283200 lb-in

i [ratio]	n_a [rpm]	T_a max [lb-in]	P_e [HP]	$F_{Ra}^{1)}$ [lb]	F_{Re} [lb]	Stages		ϕ (°/R) [']		
						Lg	Sm			
369	4.6	283200	22	33720	1960	3	2	-	-	K167R97 AD6
423	4.0	283200	19.5	33720	2010	3	2	-	-	
481	3.5	283200	17.1	33720	1980	3	2	-	-	
561	3.0	283200	14.7	33720	2060	3	2	-	-	
632	2.7	283200	13.0	33720	2040	3	2	-	-	
757	2.2	283200	10.9	33720	2080	3	2	-	-	
843	2.0	283200	9.8	33720	2110	3	2	-	-	
944	1.8	283200	8.7	33720	2090	3	2	-	-	
1101	1.5	283200	7.5	33720	2120	3	2	-	-	
2263	0.75	283200	3.7	33720	2170	3	3	-	-	
4788	0.36	283200	1.7	33720	2190	3	3	-	-	

Weight [lbs]	Stages		AD3	AD4	AD5	AD6
	Large	Small				
K167R97	3	2	2601	2613	2649	2679
	3	3	2608	2619	2656	2686
KH167: -84 lbs						

10.2.29 K167R107

K167R107 AD.. , $n_e = 1700$ rpm										283200 lb-in		
i [ratio]	n_a [rpm]	T_a max [lb-in]	P_e [HP]	$F_{Ra}^{1)}$ [lb]	F_{Re} [lb]	Stages		ϕ (/R) [']				
						Lg	Sm					
180	9.4	279660	45	33720	570	3	2	-	-			
206	8.3	283200	40	33720	590	3	2	-	-			
213	8.0	283200	39	33720	600	3	2	-	-			
244	7.0	283200	34	33720	620	3	2	-	-			
278	6.1	283200	30	33720	640	3	2	-	-			
318	5.3	283200	26	33720	660	3	2	-	-			
118	14	283200	70	33720	990	3	2	-	-			
135	13	283200	61	33720	1030	3	2	-	-			
160	11	283200	51	33720	1070	3	2	-	-			
180	9.4	283200	46	33720	1250	3	2	-	-			
206	8.3	283200	40	33720	1270	3	2	-	-			
213	8.0	283200	39	33720	1280	3	2	-	-			
244	7.0	283200	34	33720	1300	3	2	-	-			
278	6.1	283200	30	33720	1310	3	2	-	-			
318	5.3	283200	26	33720	1330	3	2	-	-			
118	14	283200	70	33720	1610	3	2	-	-			
135	13	283200	61	33720	1640	3	2	-	-			
160	11	283200	51	33720	1680	3	2	-	-			
180	9.4	283200	46	33720	1850	3	2	-	-			
206	8.3	283200	40	33720	1870	3	2	-	-			
213	8.0	283200	39	33720	1880	3	2	-	-			
244	7.0	283200	34	33720	1900	3	2	-	-			
278	6.1	283200	30	33720	1910	3	2	-	-			
318	5.3	283200	26	33720	1920	3	2	-	-			



Weight [lbs]	Stages		AD4	AD5	AD6
	Large	Small			
K167R107	3	2	2720	2750	2780

KH167: -84 lbs

10 K - Helical Bevel



K.. AD

10.2.30 K187

K187 AD.. , n _e = 1700 rpm										442500 lb-in		
i [ratio]	n _a [rpm]	T _{a max} [lb-in]	P _e [HP]	F _{Ra} ¹⁾ [lb]	F _{Re} [lb]	Stages		φ (/R) [']				
						Lg	Sm					
144.59	12	442500	86	38490	980	3	-	4	-			
165.21	10	442500	76	40780	1050	3	-	4	-		K187	AD6
179.86	9.5	442500	69	42280	1090	3	-	4	-			
88.00	19	438960	141	30900	2300	3	-	4	M1-6			
102.16	17	442500	122	32970	2460	3	-	4	M1-6			
112.60	15	442500	111	34460	2550	3	-	4	M1-6			
129.69	13	442500	96	36700	2730	3	-	4	M2-6		K187	AD7
144.59	12	442500	86	38490	2820	3	-	4	-			
165.21	10	442500	76	40780	2950	3	-	4	-			
179.86	9.5	442500	69	42280	3020	3	-	4	-			
17.18	99	283200	465	18370	4040	3	-	4	M1-6			
20.15	84	288510	404	19600	4170	3	-	4	M1-6			
24.18	70	346040	404	19080	3960	3	-	4	M1-6			
27.92	61	383210	387	19070	3850	3	-	4	M1-6			
33.23	51	410640	349	19810	3830	3	-	4	M1-6			
38.57	44	354000	259	23690	4280	3	-	4	M1-6			
42.51	40	354000	235	24800	4330	3	-	4	M1-6			
45.50	37	442500	274	22120	4980	3	-	4	M1-6		K187	AD8
53.36	32	442500	234	24050	5090	3	-	4	M1-6			
64.04	27	442500	195	26380	5200	3	-	4	M1-6			
73.96	23	442500	169	28310	5260	3	-	4	M1-6			
88.00	19	442500	142	30760	5330	3	-	4	M1-6			
102.16	17	442500	122	32970	5380	3	-	4	M1-6			
112.60	15	442500	111	34460	5400	3	-	4	M1-6			
129.69	13	442500	96	36700	5450	3	-	4	M2-6			
144.59	12	442500	86	38490	5480	3	-	4	-			

Weight [lbs]	Stages		AD6	AD7	AD8
	Large	Small			
K187	3	-	3697	3684	3736
KH187: -150 lbs					

10.2.31 K187R97

K187R97 AD.. , n _e = 1700 rpm										442500 lb-in	
i [ratio]	n _a [rpm]	T _a max [lb-in]	P _e [HP]	F _{Re} ¹⁾ [lb]	F _{Re} [lb]	Stages		φ (°/R) [']			
						Lg	Sm				
738	2.3	442500	17.4	42710	300	3	2	-	-		
945	1.8	442500	13.6	42710	370	3	2	-	-		
1046	1.6	442500	12.3	42710	370	3	2	-	-		
1196	1.4	442500	10.8	42710	400	3	2	-	-		
1395	1.2	442500	9.2	42710	450	3	2	-	-		
1605	1.1	442500	8.0	42710	440	3	2	-	-		
1821	0.93	442500	7.1	42710	460	3	2	-	-		
2054	0.83	442500	6.3	42710	470	3	2	-	-		
2268	0.75	442500	5.7	42710	470	3	2	-	-		
2519	0.67	442500	5.1	42710	480	3	2	-	-		
2818	0.60	442500	4.6	42710	520	3	3	-	-		
3062	0.56	442500	4.2	42710	480	3	2	-	-		
3609	0.47	442500	3.6	42710	490	3	2	-	-		
4370	0.39	442500	3.0	42710	530	3	3	-	-		
4817	0.35	442500	2.7	42710	540	3	3	-	-		
5358	0.32	442500	2.4	42710	540	3	3	-	-		
5991	0.28	442500	2.2	42710	540	3	3	-	-		
6747	0.25	442500	1.9	42710	540	3	3	-	-		
7343	0.23	442500	1.8	42710	540	3	3	-	-		
8126	0.21	442500	1.6	42710	560	3	3	-	-		
9363	0.18	442500	1.4	42710	560	3	3	-	-		
10413	0.16	442500	1.3	42710	560	3	3	-	-		
11647	0.15	442500	1.1	42710	560	3	3	-	-		
13116	0.13	442500	1.0	42710	560	3	3	-	-		
14272	0.12	442500	0.92	42710	560	3	3	-	-		
16978	0.10	442500	0.77	42710	560	3	3	-	-		
19144	0.09	442500	0.68	42710	560	3	3	-	-		
24353	0.07	442500	0.54	42710	560	3	3	-	-		
527	3.2	442500	24	42710	670	3	2	-	-		
621	2.7	442500	21	42710	690	3	2	-	-		
738	2.3	442500	17.4	42710	730	3	2	-	-		
945	1.8	442500	13.6	42710	790	3	2	-	-		
1046	1.6	442500	12.3	42710	800	3	2	-	-		
1196	1.4	442500	10.8	42710	820	3	2	-	-		
1395	1.2	442500	9.2	42710	860	3	2	-	-		
1605	1.1	442500	8.0	42710	850	3	2	-	-		
1821	0.93	442500	7.1	42710	880	3	2	-	-		
2054	0.83	442500	6.3	42710	880	3	2	-	-		
2268	0.75	442500	5.7	42710	880	3	2	-	-		
2519	0.67	442500	5.1	42710	890	3	2	-	-		
2818	0.60	442500	4.6	42710	920	3	3	-	-		
3062	0.56	442500	4.2	42710	890	3	2	-	-		
3609	0.47	442500	3.6	42710	900	3	2	-	-		
4370	0.39	442500	3.0	42710	940	3	3	-	-		
4817	0.35	442500	2.7	42710	940	3	3	-	-		
5358	0.32	442500	2.4	42710	940	3	3	-	-		
5991	0.28	442500	2.2	42710	940	3	3	-	-		
6747	0.25	442500	1.9	42710	950	3	3	-	-		
7343	0.23	442500	1.8	42710	950	3	3	-	-		
8126	0.21	442500	1.6	42710	960	3	3	-	-		
9363	0.18	442500	1.4	42710	960	3	3	-	-		
10413	0.16	442500	1.3	42710	960	3	3	-	-		
11647	0.15	442500	1.1	42710	960	3	3	-	-		
13116	0.13	442500	1.0	42710	960	3	3	-	-		
14272	0.12	442500	0.92	42710	970	3	3	-	-		
16978	0.10	442500	0.77	42710	970	3	3	-	-		

K187R97 AD3



K187R97 AD4

10 K - Helical Bevel

K.. AD



K187R97 AD.. , n_e = 1700 rpm

442500 lb-in

i [ratio]	n _a [rpm]	T _a max [lb-in]	P _e [HP]	F _{Ra} ¹⁾ [lb]	F _{Re} [lb]	Stages		φ (°/R) [']			
						Lg	Sm				
527	3.2	442500	24	42710	1340	3	2	-	-	K187R97 AD5	
621	2.7	442500	21	42710	1360	3	2	-	-		
738	2.3	442500	17.4	42710	1410	3	2	-	-		
945	1.8	442500	13.6	42710	1460	3	2	-	-		
1046	1.6	442500	12.3	42710	1460	3	2	-	-		
1196	1.4	442500	10.8	42710	1490	3	2	-	-		
1395	1.2	442500	9.2	42710	1530	3	2	-	-		
1605	1.1	442500	8.0	42710	1520	3	2	-	-		
1821	0.93	442500	7.1	42710	1540	3	2	-	-		
2054	0.83	442500	6.3	42710	1550	3	2	-	-		
2268	0.75	442500	5.7	42710	1550	3	2	-	-		
2519	0.67	442500	5.1	42710	1550	3	2	-	-		
2818	0.60	442500	4.6	42710	1590	3	3	-	-		
4370	0.39	442500	3.0	42710	1600	3	3	-	-		
4817	0.35	442500	2.7	42710	1600	3	3	-	-		
5358	0.32	442500	2.4	42710	1610	3	3	-	-		
5991	0.28	442500	2.2	42710	1610	3	3	-	-		
6747	0.25	442500	1.9	42710	1610	3	3	-	-		
8126	0.21	442500	1.6	42710	1620	3	3	-	-		
9363	0.18	442500	1.4	42710	1630	3	3	-	-		
10413	0.16	442500	1.3	42710	1630	3	3	-	-		
11647	0.15	442500	1.1	42710	1630	3	3	-	-		
13116	0.13	442500	1.0	42710	1630	3	3	-	-		
527	3.2	442500	24	42710	1930	3	2	-	-		K187R97 AD6
621	2.7	442500	21	42710	1950	3	2	-	-		
738	2.3	442500	17.4	42710	2000	3	2	-	-		
945	1.8	442500	13.6	42710	2050	3	2	-	-		
1046	1.6	442500	12.3	42710	2050	3	2	-	-		
1196	1.4	442500	10.8	42710	2070	3	2	-	-		
1395	1.2	442500	9.2	42710	2110	3	2	-	-		
1605	1.1	442500	8.0	42710	2100	3	2	-	-		
1821	0.93	442500	7.1	42710	2120	3	2	-	-		
2054	0.83	442500	6.3	42710	2130	3	2	-	-		
2268	0.75	442500	5.7	42710	2130	3	2	-	-		
2818	0.60	442500	4.6	42710	2170	3	3	-	-		
4370	0.39	442500	3.0	42710	2180	3	3	-	-		
4817	0.35	442500	2.7	42710	2180	3	3	-	-		
5358	0.32	442500	2.4	42710	2180	3	3	-	-		
8126	0.21	442500	1.6	42710	2200	3	3	-	-		
9363	0.18	442500	1.4	42710	2200	3	3	-	-		
10413	0.16	442500	1.3	42710	2200	3	3	-	-		

Weight [lbs]	Stages		AD3	AD4	AD5	AD6
	Large	Small				
K187R97	3	2	3884	3896	3932	3962
	3	3	3891	3902	3939	3969
KH187: -150 lbs						

10.2.32 K187R107

K187R107 AD.. , $n_e = 1700$ rpm										442500 lb-in	
i [ratio]	n_a [rpm]	$T_{a \max}$ [lb-in]	P_e [HP]	$F_{Ra}^{1)}$ [lb]	F_{Re} [lb]	Stages		ϕ (°/R) [']			
						Lg	Sm				
729	2.3	442500	17.7	42710	350	3	2	-	-	K187R107	AD3
835	2.0	442500	15.4	42710	360	3	2	-	-		
163	10	253110	45	42710	580	3	2	-	-	K187R107	AD4
193	8.8	294710	44	42710	550	3	2	-	-		
221	7.7	325680	43	42710	530	3	2	-	-		
261	6.5	367280	41	42710	500	3	2	-	-		
355	4.8	442500	36	42710	600	3	2	-	-		
454	3.7	442500	28	42710	650	3	2	-	-		
520	3.3	442500	25	42710	670	3	2	-	-		
622	2.7	442500	21	42710	740	3	2	-	-		
729	2.3	442500	17.7	42710	780	3	2	-	-		
835	2.0	442500	15.4	42710	790	3	2	-	-		
163	10	424800	76	41300	1000	3	2	-	-	K187R107	AD5
193	8.8	442500	67	42710	1020	3	2	-	-		
221	7.7	442500	58	42710	1050	3	2	-	-		
261	6.5	442500	49	42710	1090	3	2	-	-		
355	4.8	442500	36	42710	1270	3	2	-	-		
454	3.7	442500	28	42710	1330	3	2	-	-		
520	3.3	442500	25	42710	1340	3	2	-	-		
622	2.7	442500	21	42710	1410	3	2	-	-		
729	2.3	442500	17.7	42710	1450	3	2	-	-		
835	2.0	442500	15.4	42710	1460	3	2	-	-		
163	10	442500	79	40610	1590	3	2	-	-	K187R107	AD6
193	8.8	442500	67	42710	1630	3	2	-	-		
221	7.7	442500	58	42710	1670	3	2	-	-		
261	6.5	442500	49	42710	1700	3	2	-	-		
355	4.8	442500	36	42710	1870	3	2	-	-		
454	3.7	442500	28	42710	1920	3	2	-	-		
520	3.3	442500	25	42710	1940	3	2	-	-		
622	2.7	442500	21	42710	2000	3	2	-	-		
729	2.3	442500	17.7	42710	2030	3	2	-	-		
835	2.0	442500	15.4	42710	2040	3	2	-	-		
Weight [lbs]		Stages		AD3		AD4		AD5		AD6	
		Large	Small								
K187R107		3	2	3989		4003		4033		4063	
KH187: -150 lbs											

10 K - Helical Bevel

K.. AM.. [NEMA dimensions]

10.3 K.. AM.. [NEMA dimensions]

K19..

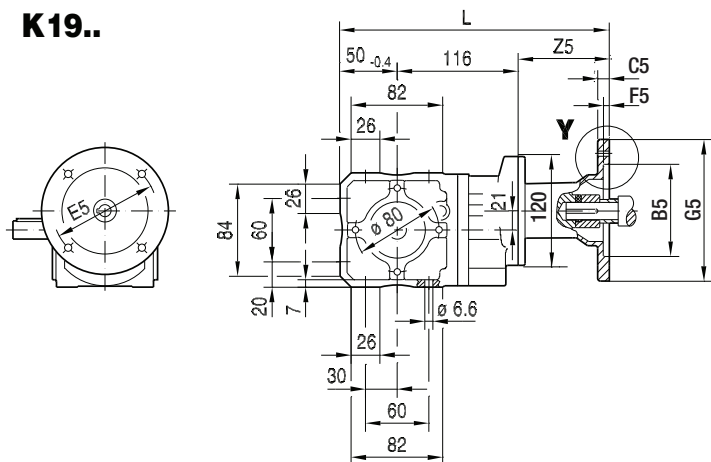

33 055 00 13

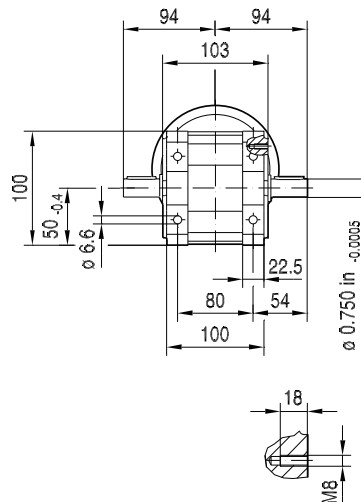

KA19B..

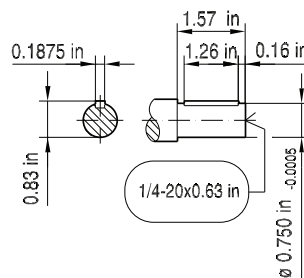
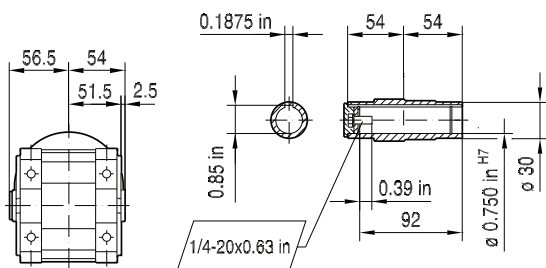

KH19B..

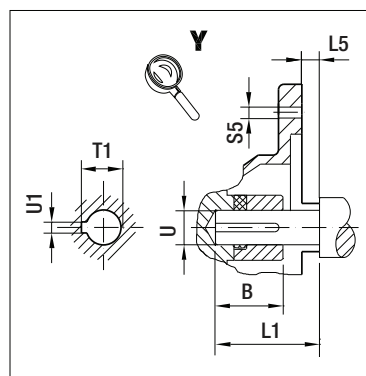
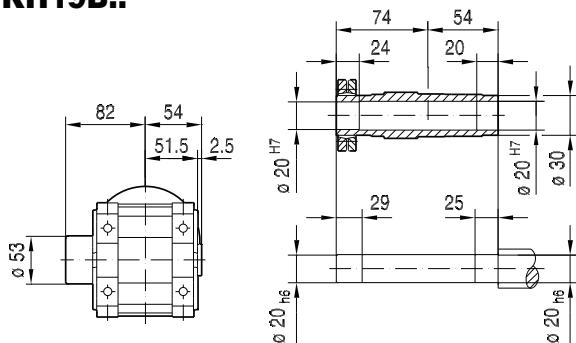

(→ 132)	B	B5	C5	E5	F5	G5	L	L1	L5	S5	T1	U	U1	Z5
AM56	1.23 in	4.50 in	11	5.875 in	4.5	170	260	1.88 in	-0.18 in	10.5	0.71 in	0.625 in	0.188 in	93.5
AM143	1.68 in	4.50 in	12	5.875 in	4.5	170	283	2.25 in	0.13 in	10.5	0.98 in	0.875 in	0.188 in	117
AM145	1.68 in	4.50 in	12	5.875 in	4.5	170	283	2.25 in	0.13 in	10.5	0.98 in	0.875 in	0.188 in	117

Dimensions in mm unless otherwise noted. For all available output shaft diameters, see page 573.

33 056 00 13

KF19..

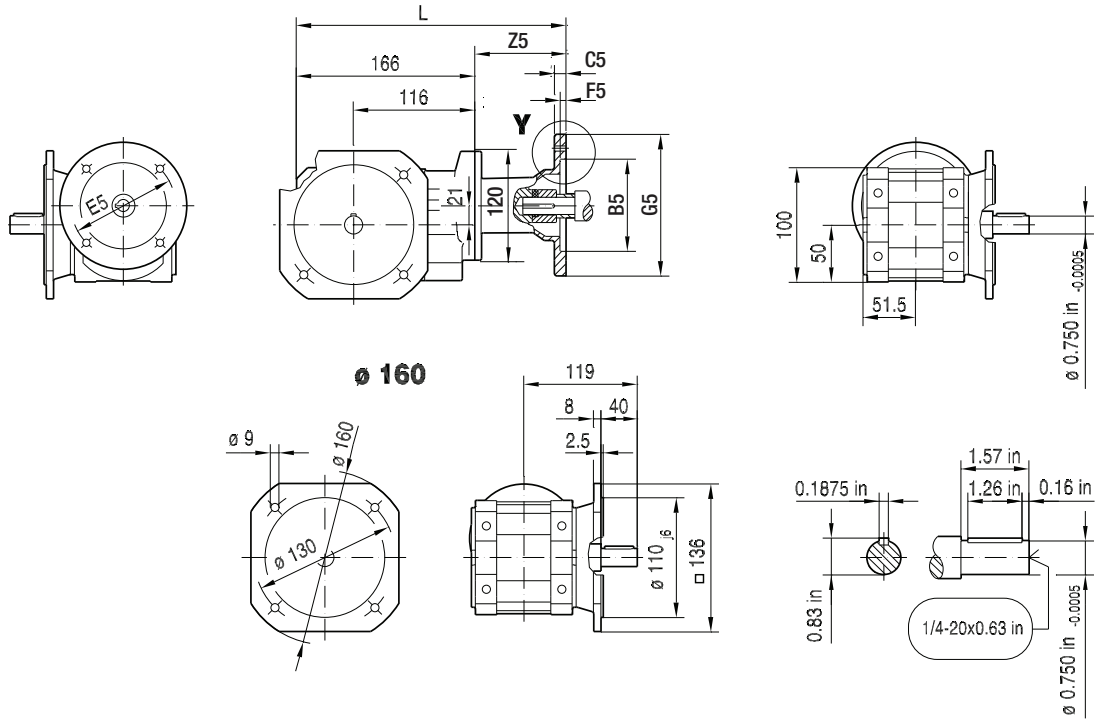

10

KAF19..

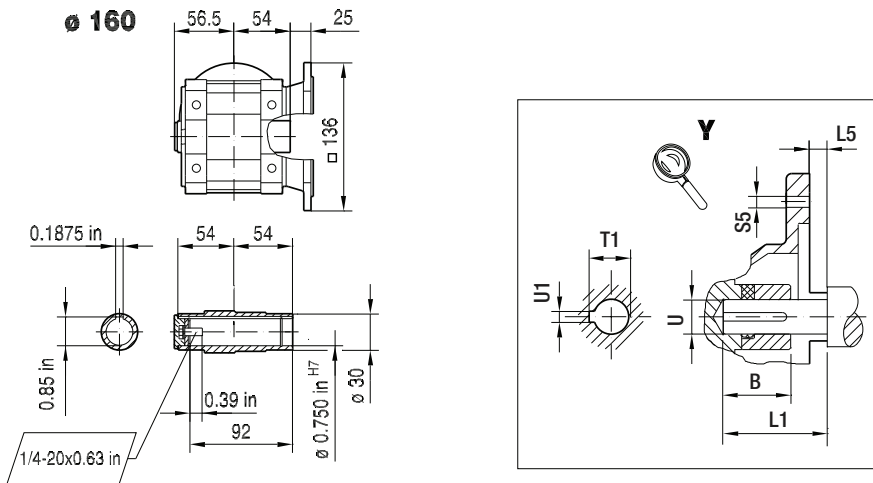

(→ 132)	B	B5	C5	E5	F5	G5	L	L1	L5	S5	T1	U	U1	Z5
AM56	1.23 in	4.50 in	11	5.875 in	4.5	170	260	1.88 in	-0.18 in	10.5	0.71 in	0.625 in	0.188 in	93.5
AM143	1.68 in	4.50 in	12	5.875 in	4.5	170	283	2.25 in	0.13 in	10.5	0.98 in	0.875 in	0.188 in	117
AM145	1.68 in	4.50 in	12	5.875 in	4.5	170	283	2.25 in	0.13 in	10.5	0.98 in	0.875 in	0.188 in	117

Dimensions in mm unless otherwise noted. For all available output shaft diameters, see page 573.

10 K - Helical Bevel

K.. AM.. [NEMA dimensions]

KHF19..

33 057 00 13

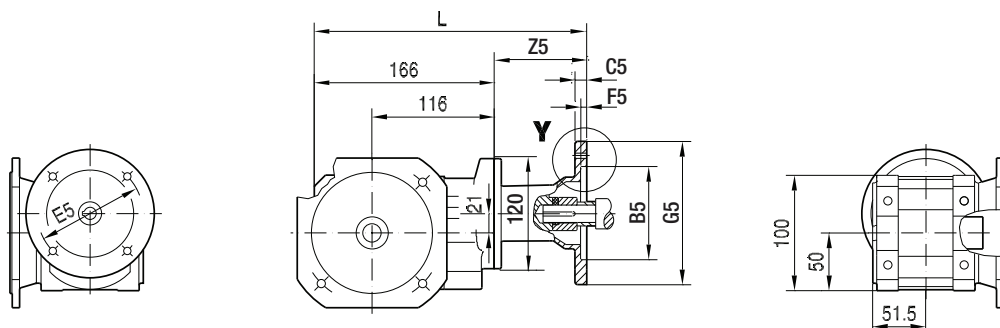

ø 160

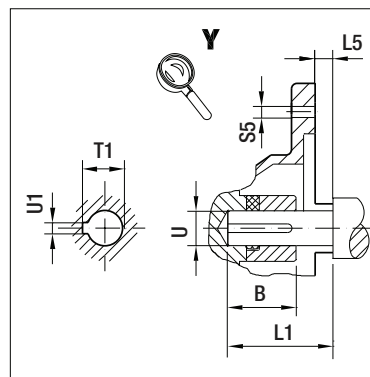
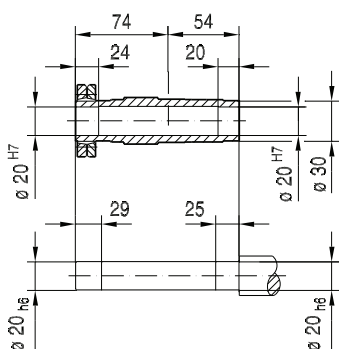
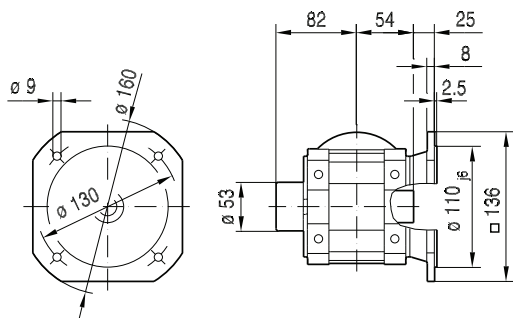

(→ 132)	B	B5	C5	E5	F5	G5	L	L1	L5	S5	T1	U	U1	Z5
AM56	1.23 in	4.50 in	11	5.875 in	4.5	170	260	1.88 in	-0.18 in	10.5	0.71 in	0.625 in	0.188 in	93.5
AM143	1.68 in	4.50 in	12	5.875 in	4.5	170	283	2.25 in	0.13 in	10.5	0.98 in	0.875 in	0.188 in	117
AM145	1.68 in	4.50 in	12	5.875 in	4.5	170	283	2.25 in	0.13 in	10.5	0.98 in	0.875 in	0.188 in	117

KA19..

33 058 00 13

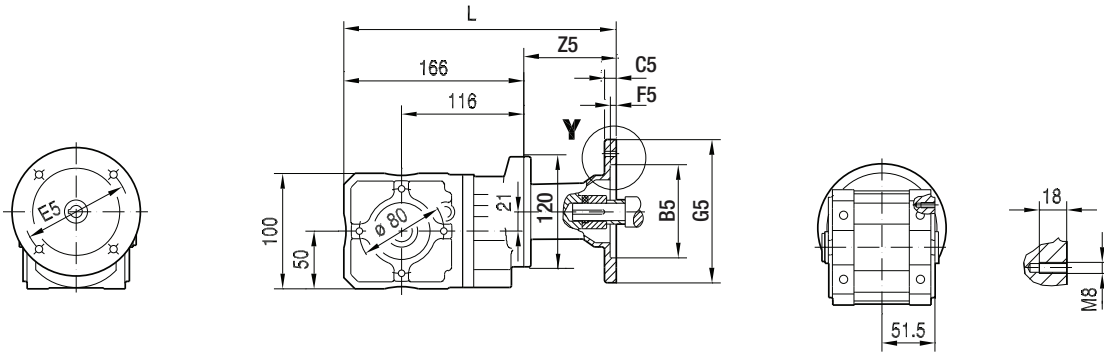

KA19..

KH19..

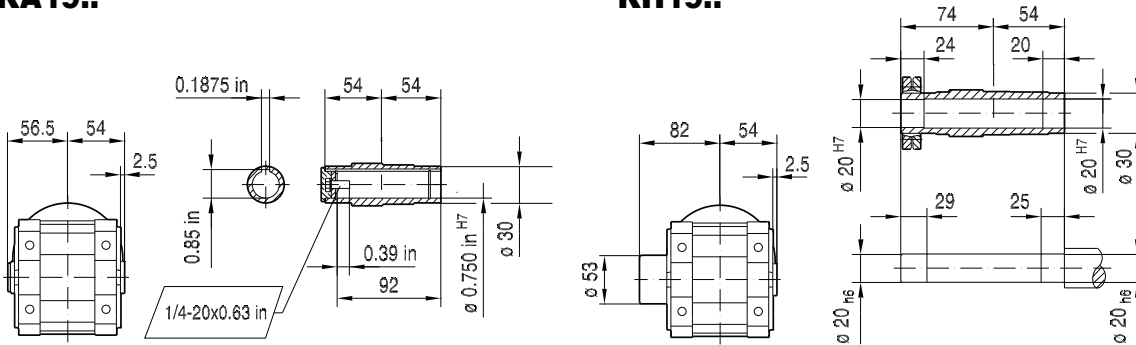

10

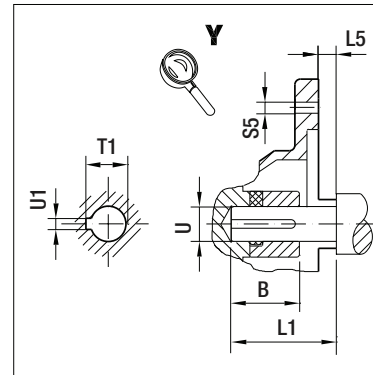
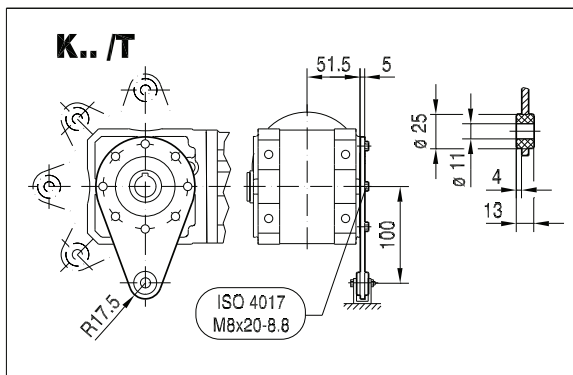

(→ 132)	B	B5	C5	E5	F5	G5	L	L1	L5	S5	T1	U	U1	Z5
AM56	1.23 in	4.50 in	11	5.875 in	4.5	170	260	1.88 in	-0.18 in	10.5	0.71 in	0.625 in	0.188 in	93.5
AM143	1.68 in	4.50 in	12	5.875 in	4.5	170	283	2.25 in	0.13 in	10.5	0.98 in	0.875 in	0.188 in	117
AM145	1.68 in	4.50 in	12	5.875 in	4.5	170	283	2.25 in	0.13 in	10.5	0.98 in	0.875 in	0.188 in	117

Dimensions in mm unless otherwise noted. For all available output shaft diameters, see page 575.

10 K - Helical Bevel

K.. AM.. [NEMA dimensions]

K29..

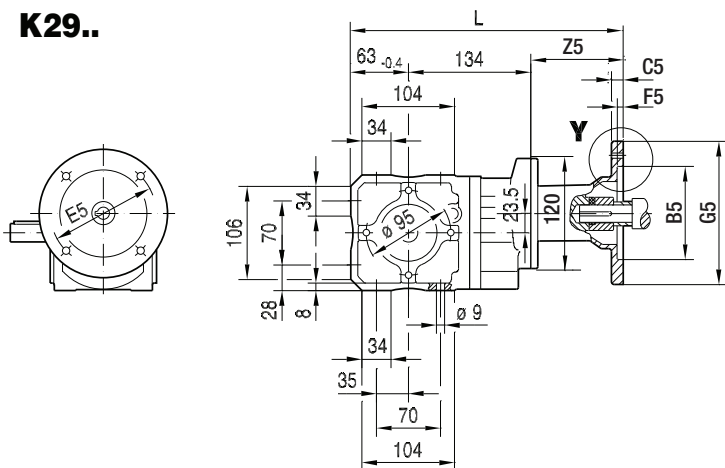

33 059 00 13

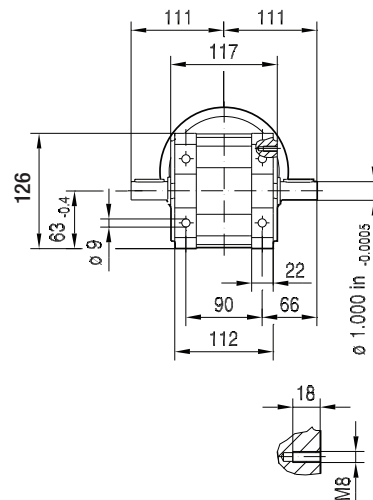

KA29B..

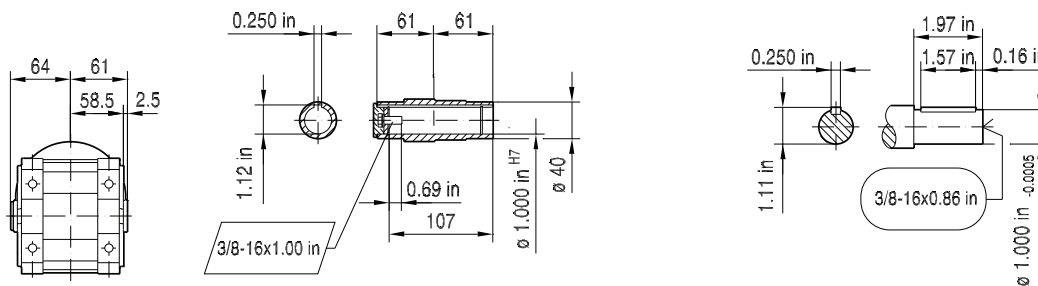

KH29B..

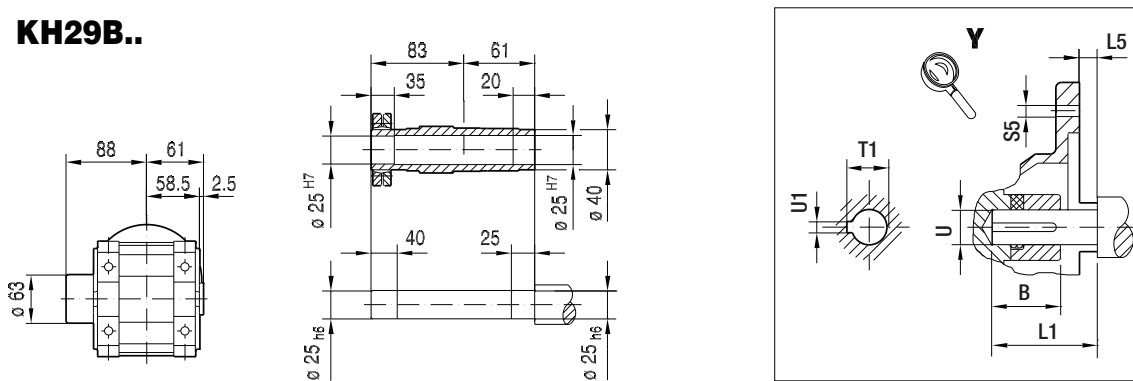

(→ 132)	B	B5	C5	E5	F5	G5	L	L1	L5	S5	T1	U	U1	Z5
AM56	1.23 in	4.50 in	11	5.875 in	4.5	170	291	1.88 in	-0.18 in	10.5	0.71 in	0.625 in	0.188 in	93.5
AM143	1.68 in	4.50 in	12	5.875 in	4.5	170	314	2.25 in	0.13 in	10.5	0.98 in	0.875 in	0.188 in	117
AM145	1.68 in	4.50 in	12	5.875 in	4.5	170	314	2.25 in	0.13 in	10.5	0.98 in	0.875 in	0.188 in	117

Dimensions in mm unless otherwise noted. For all available output shaft diameters, see page 573.

33 060 00 13

KF29..

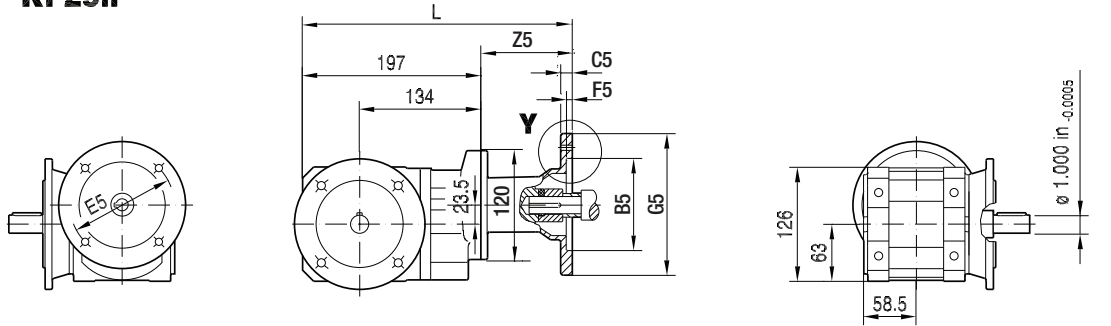

ø 160

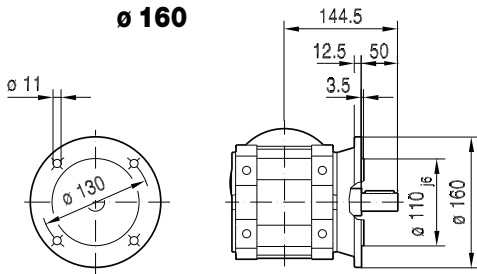

ø 200

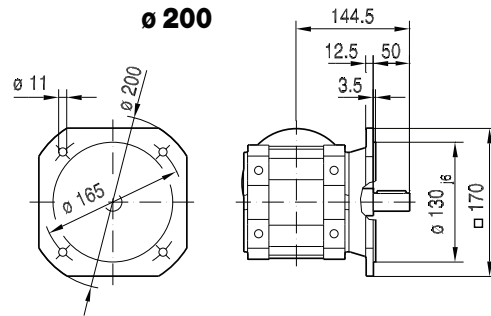

KAF29..

ø 160

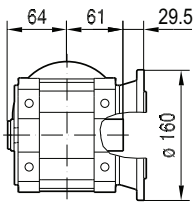

ø 200

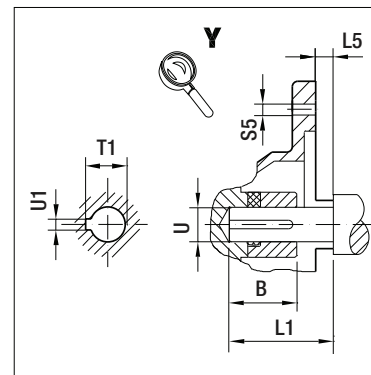
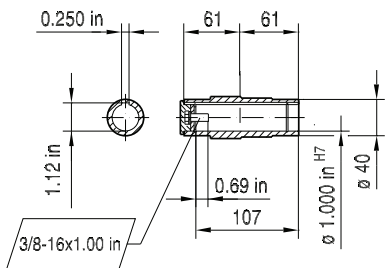
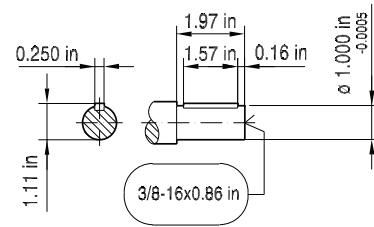
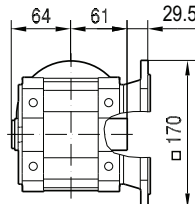

10

(→ 132)	B	B5	C5	E5	F5	G5	L	L1	L5	S5	T1	U	U1	Z5
AM56	1.23 in	4.50 in	11	5.875 in	4.5	170	291	1.88 in	-0.18 in	10.5	0.71 in	0.625 in	0.188 in	93.5
AM143	1.68 in	4.50 in	12	5.875 in	4.5	170	314	2.25 in	0.13 in	10.5	0.98 in	0.875 in	0.188 in	117
AM145	1.68 in	4.50 in	12	5.875 in	4.5	170	314	2.25 in	0.13 in	10.5	0.98 in	0.875 in	0.188 in	117

Dimensions in mm unless otherwise noted. For all available output shaft diameters, see page 573.

10 K - Helical Bevel

K.. AM.. [NEMA dimensions]

33 061 00 13

KHF29..

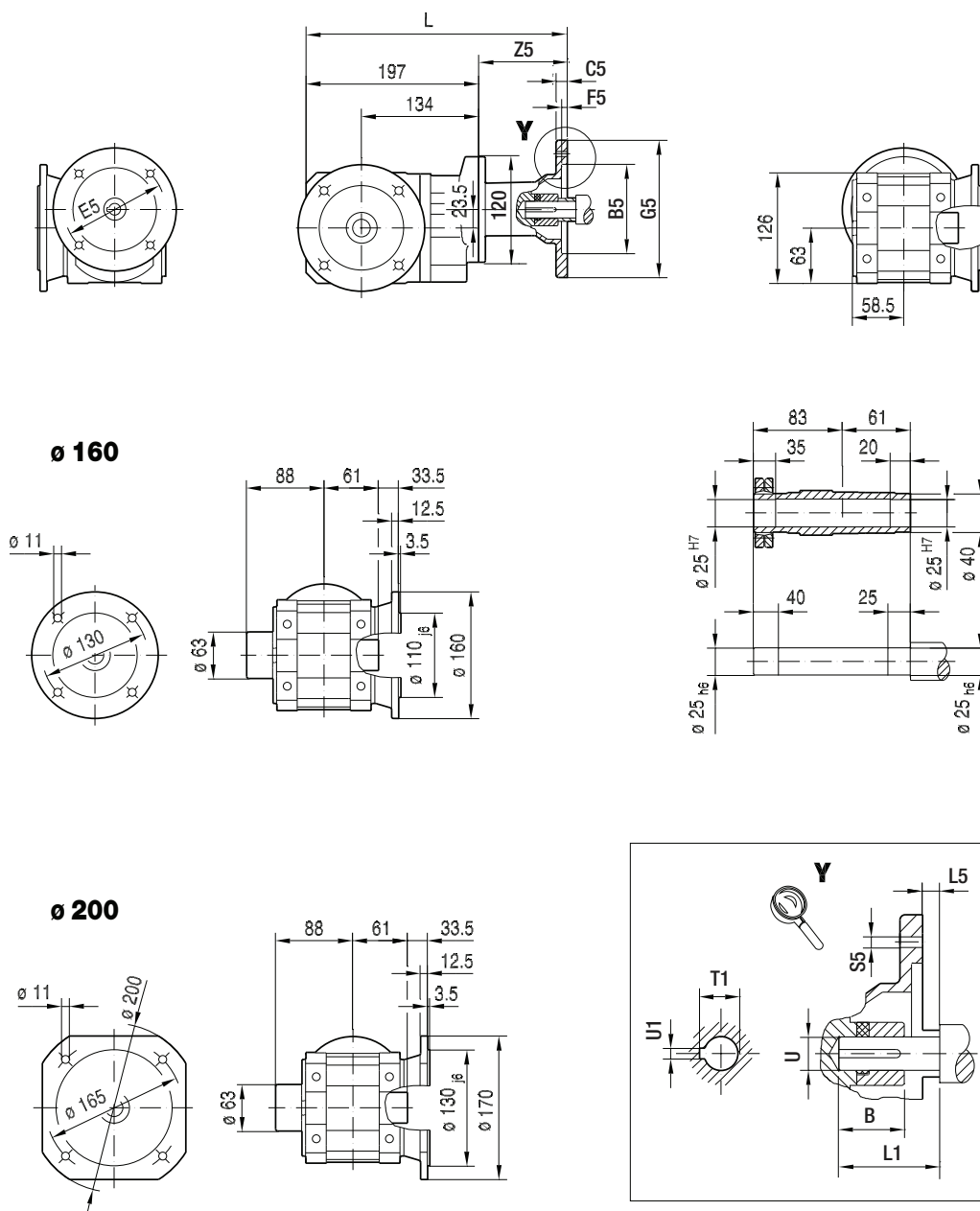

(→ 132)	B	B5	C5	E5	F5	G5	L	L1	L5	S5	T1	U	U1	Z5
AM56	1.23 in	4.50 in	11	5.875 in	4.5	170	291	1.88 in	-0.18 in	10.5	0.71 in	0.625 in	0.188 in	93.5
AM143	1.68 in	4.50 in	12	5.875 in	4.5	170	314	2.25 in	0.13 in	10.5	0.98 in	0.875 in	0.188 in	117
AM145	1.68 in	4.50 in	12	5.875 in	4.5	170	314	2.25 in	0.13 in	10.5	0.98 in	0.875 in	0.188 in	117

KA29..

33 062 00 13

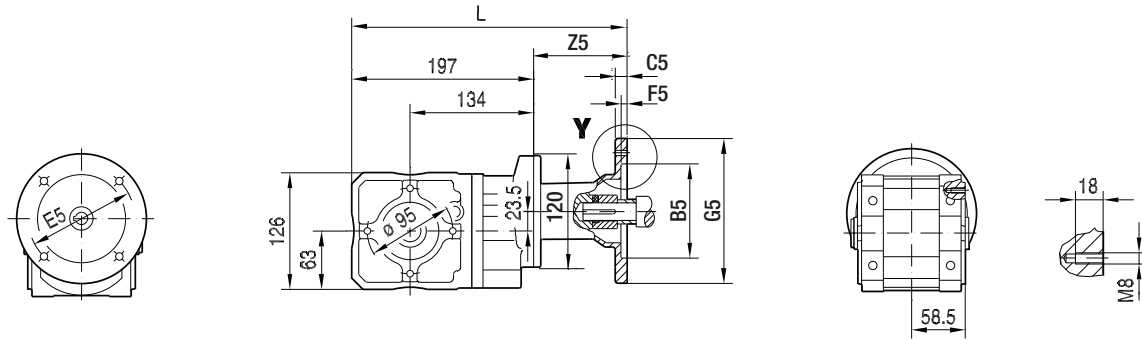

KA29..

KH29..

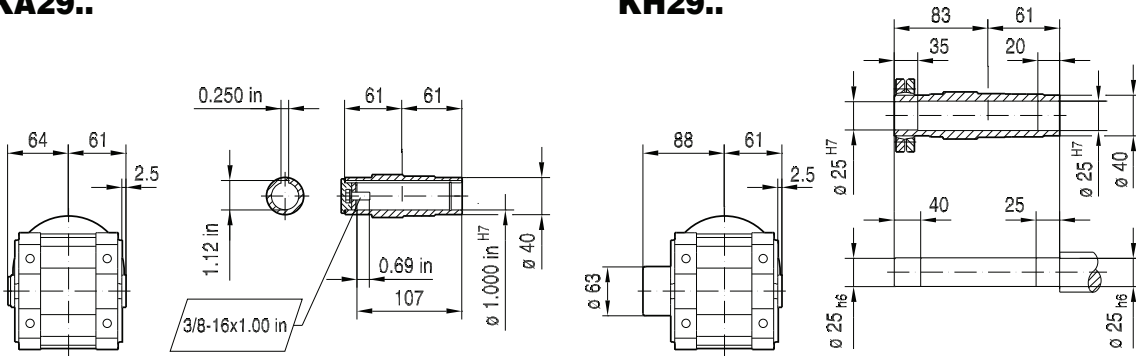

10

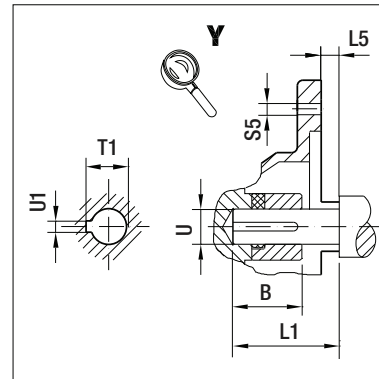
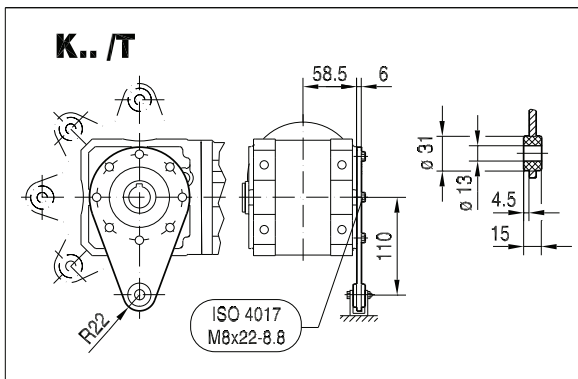

(→ 132)	B	B5	C5	E5	F5	G5	L	L1	L5	S5	T1	U	U1	Z5
AM56	1.23 in	4.50 in	11	5.875 in	4.5	170	291	1.88 in	-0.18 in	10.5	0.71 in	0.625 in	0.188 in	93.5
AM143	1.68 in	4.50 in	12	5.875 in	4.5	170	314	2.25 in	0.13 in	10.5	0.98 in	0.875 in	0.188 in	117
AM145	1.68 in	4.50 in	12	5.875 in	4.5	170	314	2.25 in	0.13 in	10.5	0.98 in	0.875 in	0.188 in	117

Dimensions in mm unless otherwise noted. For all available output shaft diameters, see page 575.

10 K - Helical Bevel

K.. AM.. [NEMA dimensions]

33 008 00 11

K37..

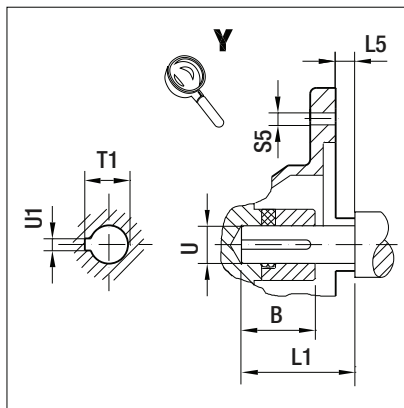
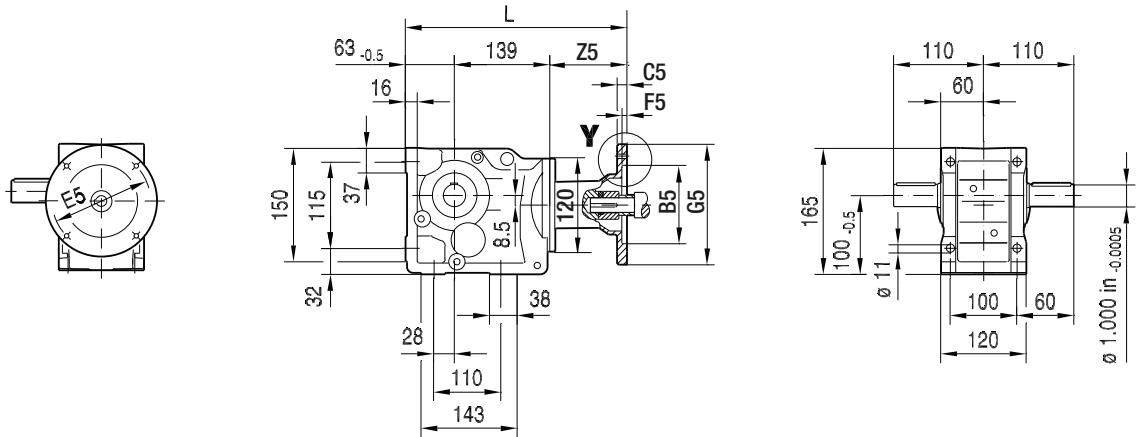

(→ 132)	B	B5	C5	E5	F5	G5	L	L1	L5	S5	T1	U	U1	Z5
AM56	1.23 in	4.50 in	11	5.875 in	4.5	170	296	1.88 in	-0.18 in	10.5	0.71 in	0.625 in	0.188 in	93.5
AM143	1.68 in	4.50 in	12	5.875 in	4.5	170	319	2.25 in	0.13 in	10.5	0.98 in	0.875 in	0.188 in	117
AM145	1.68 in	4.50 in	12	5.875 in	4.5	170	319	2.25 in	0.13 in	10.5	0.98 in	0.875 in	0.188 in	117

Dimensions in mm unless otherwise noted. For all available output shaft diameters, see page 573.

33 009 00 11

KF37..

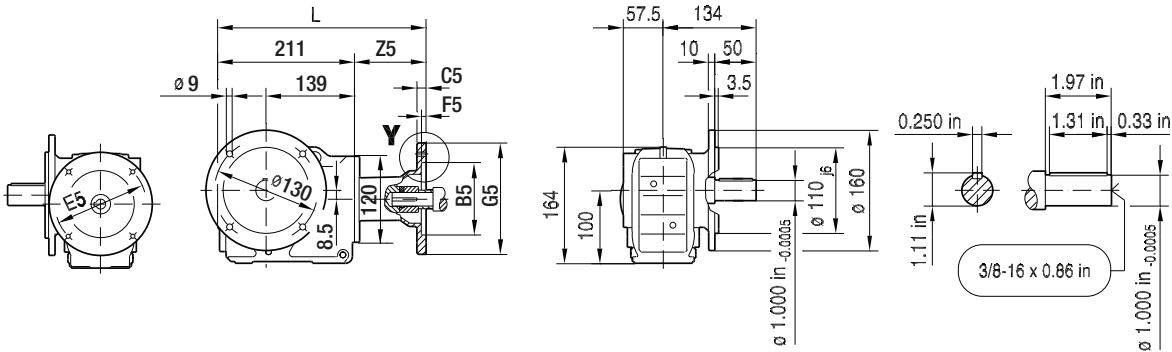

KAF37..

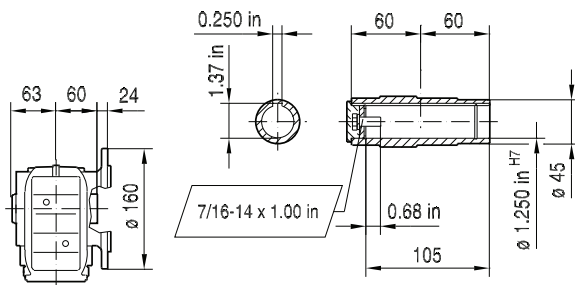

KVF37..

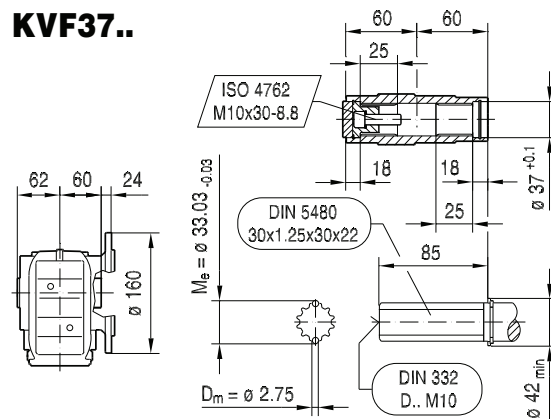

KHF37..

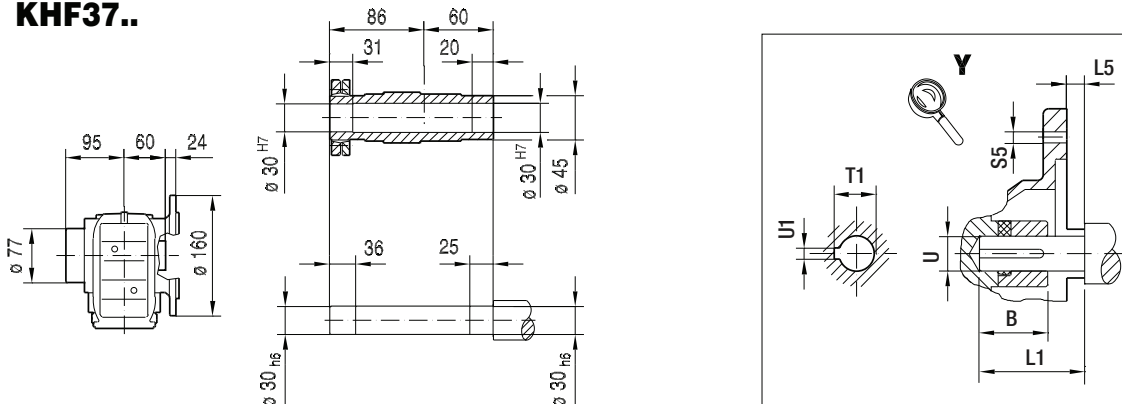

(→ 132)	B	B5	C5	E5	F5	G5	L	L1	L5	S5	T1	U	U1	Z5
AM56	1.23 in	4.50 in	11	5.875 in	4.5	170	305	1.88 in	-0.18 in	10.5	0.71 in	0.625 in	0.188 in	93.5
AM143	1.68 in	4.50 in	12	5.875 in	4.5	170	328	2.25 in	0.13 in	10.5	0.98 in	0.875 in	0.188 in	117
AM145	1.68 in	4.50 in	12	5.875 in	4.5	170	328	2.25 in	0.13 in	10.5	0.98 in	0.875 in	0.188 in	117

Dimensions in mm unless otherwise noted. For all available output shaft diameters, see page 573.

10 K - Helical Bevel

K.. AM.. [NEMA dimensions]

KA37..

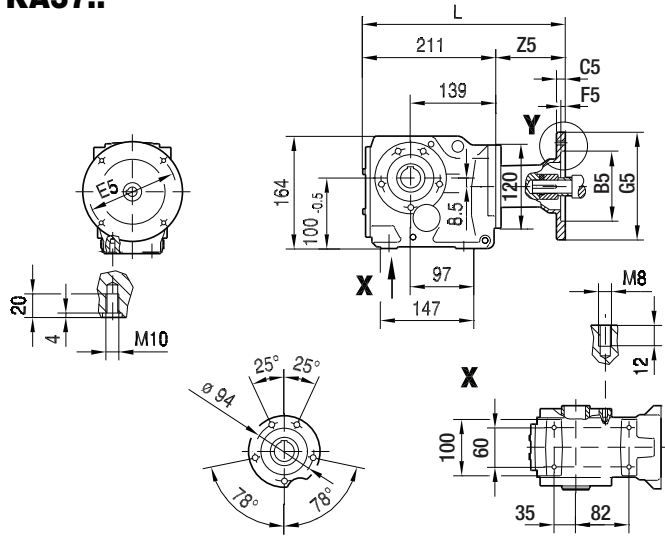

33 010 00 11

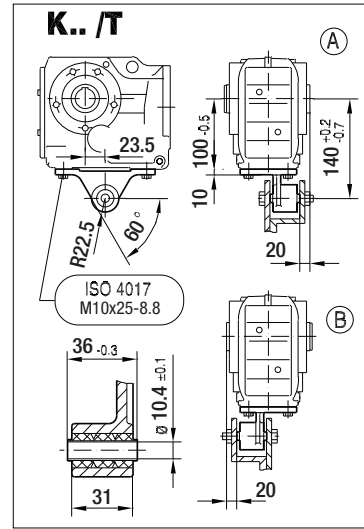

KA37..

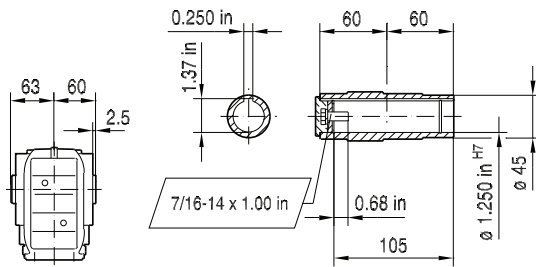

KV37..

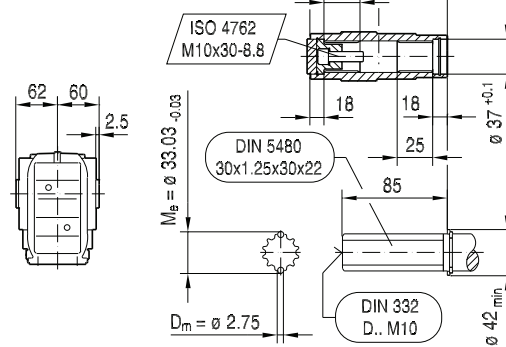

KH37..

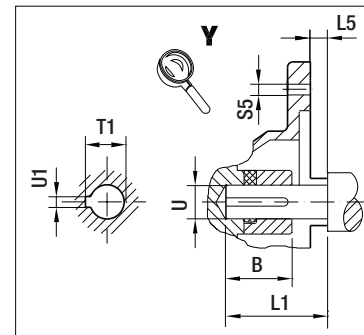
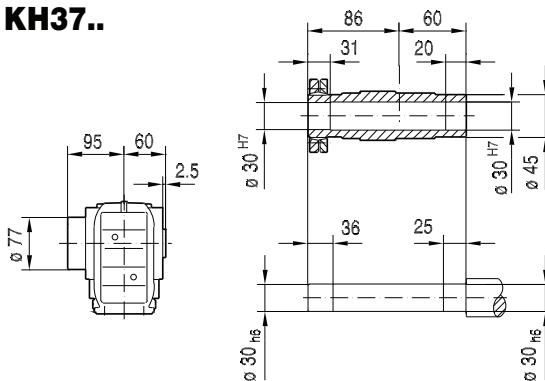

(→ 132)	B	B5	C5	E5	F5	G5	L	L1	L5	S5	T1	U	U1	Z5
AM56	1.23 in	4.50 in	11	5.875 in	4.5	170	305	1.88 in	-0.18 in	10.5	0.71 in	0.625 in	0.188 in	93.5
AM143	1.68 in	4.50 in	12	5.875 in	4.5	170	328	2.25 in	0.13 in	10.5	0.98 in	0.875 in	0.188 in	117
AM145	1.68 in	4.50 in	12	5.875 in	4.5	170	328	2.25 in	0.13 in	10.5	0.98 in	0.875 in	0.188 in	117

Dimensions in mm unless otherwise noted. For all available output shaft diameters, see page 575.

KAZ37..

33 011 00 11

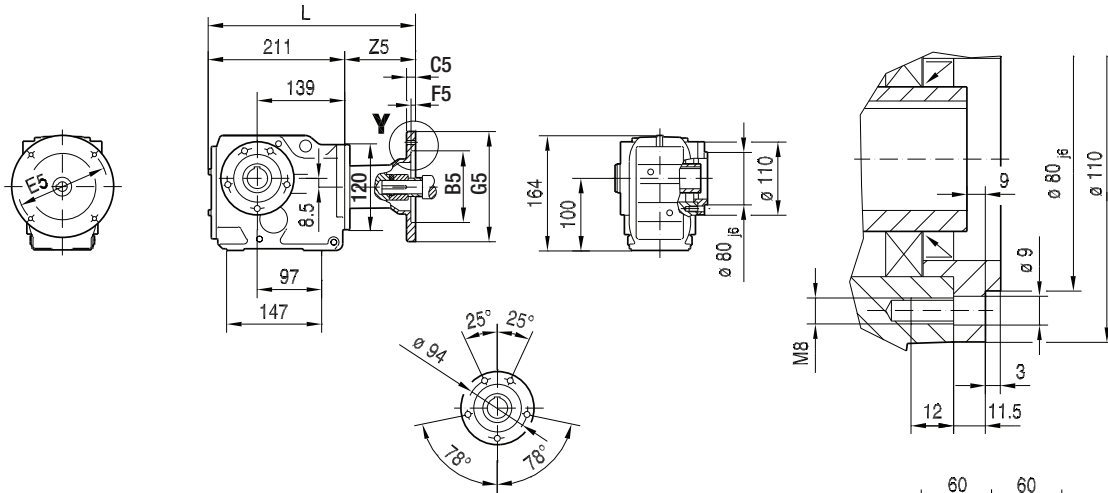

KAZ37..

KVZ37..

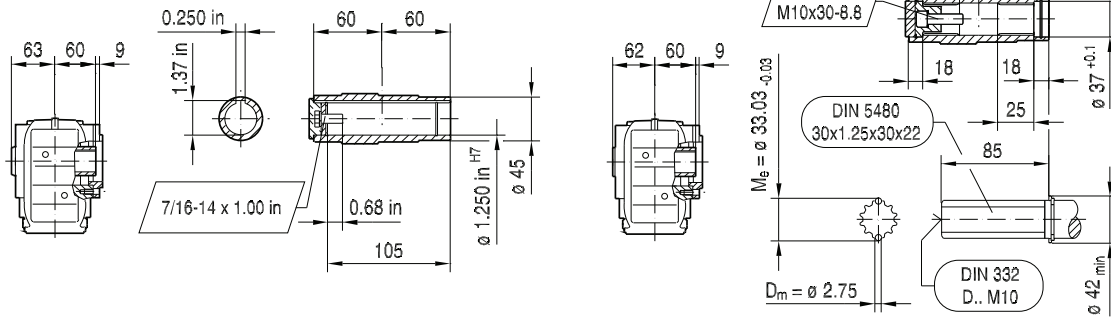

KHZ37..

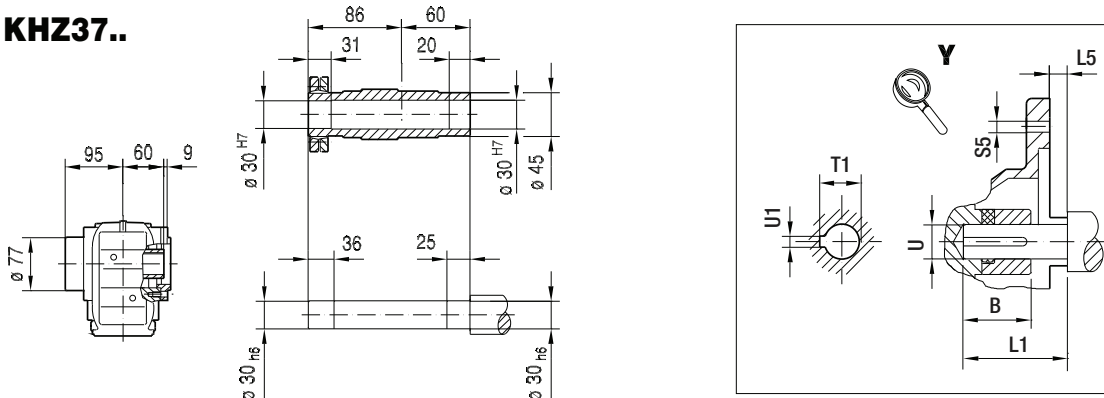

(→ 132)	B	B5	C5	E5	F5	G5	L	L1	L5	S5	T1	U	U1	Z5
AM56	1.23 in	4.50 in	11	5.875 in	4.5	170	305	1.88 in	-0.18 in	10.5	0.71 in	0.625 in	0.188 in	93.5
AM143	1.68 in	4.50 in	12	5.875 in	4.5	170	328	2.25 in	0.13 in	10.5	0.98 in	0.875 in	0.188 in	117
AM145	1.68 in	4.50 in	12	5.875 in	4.5	170	328	2.25 in	0.13 in	10.5	0.98 in	0.875 in	0.188 in	117

Dimensions in mm unless otherwise noted. For all available output shaft diameters, see page 575.

10 K - Helical Bevel

K.. AM.. [NEMA dimensions]

KT37..

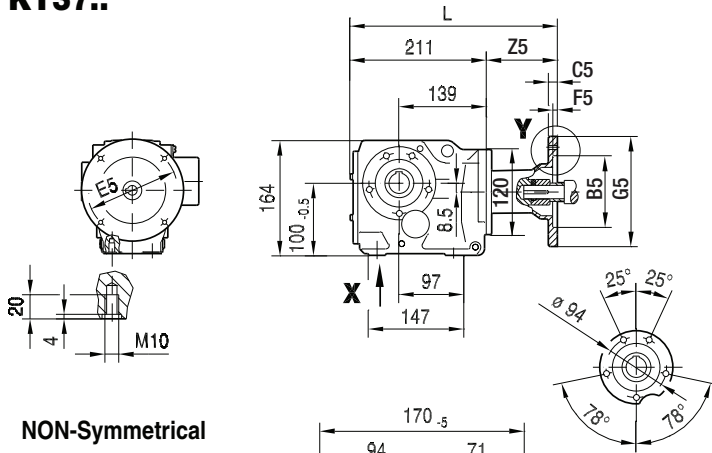

NON-Symmetrical

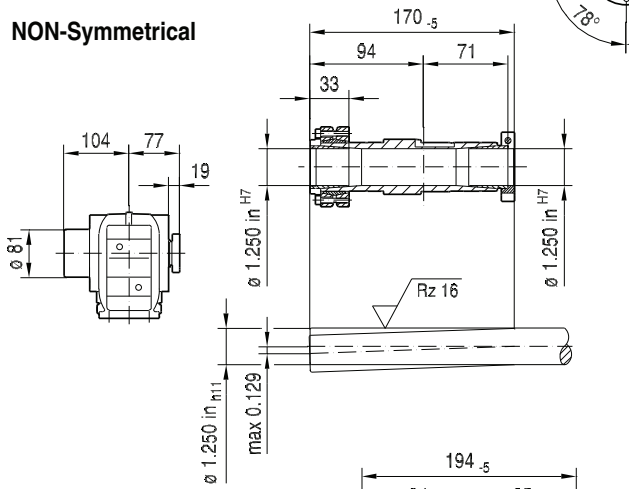

Symmetrical

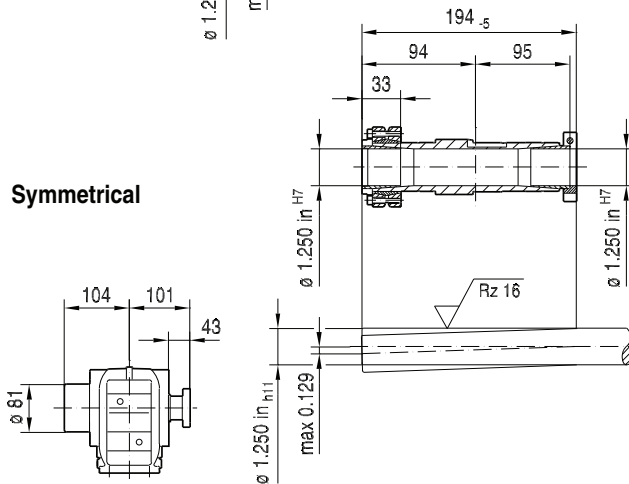

33 012 00 11

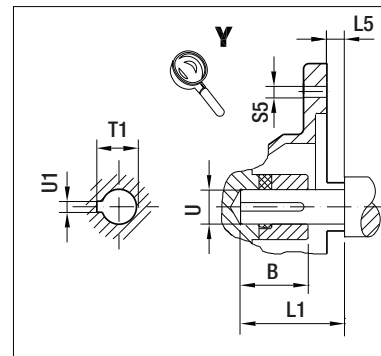
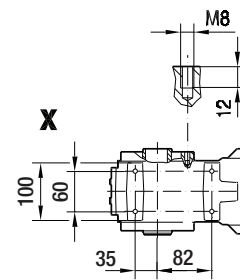
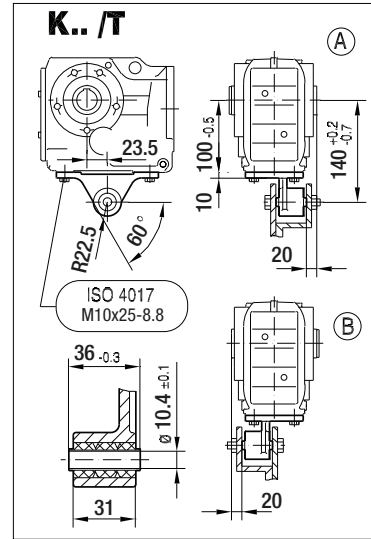

(→ 132)	B	B5	C5	E5	F5	G5	L	L1	L5	S5	T1	U	U1	Z5
AM56	1.23 in	4.50 in	11	5.875 in	4.5	170	305	1.88 in	-0.18 in	10.5	0.71 in	0.625 in	0.188 in	93.5
AM143	1.68 in	4.50 in	12	5.875 in	4.5	170	328	2.25 in	0.13 in	10.5	0.98 in	0.875 in	0.188 in	117
AM145	1.68 in	4.50 in	12	5.875 in	4.5	170	328	2.25 in	0.13 in	10.5	0.98 in	0.875 in	0.188 in	117

Dimensions in mm unless otherwise noted. For all available output shaft diameters, see page 577.

K39..

33 052 00 15US

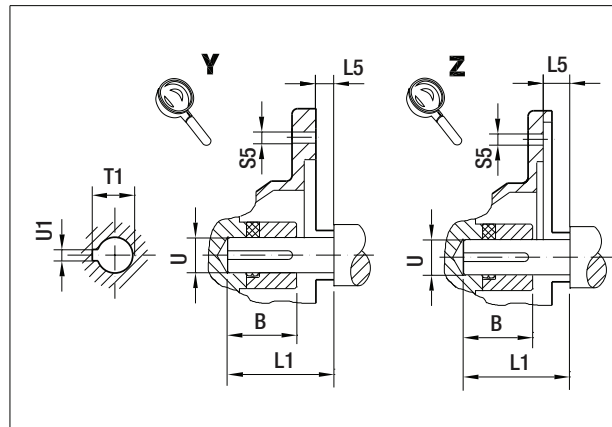
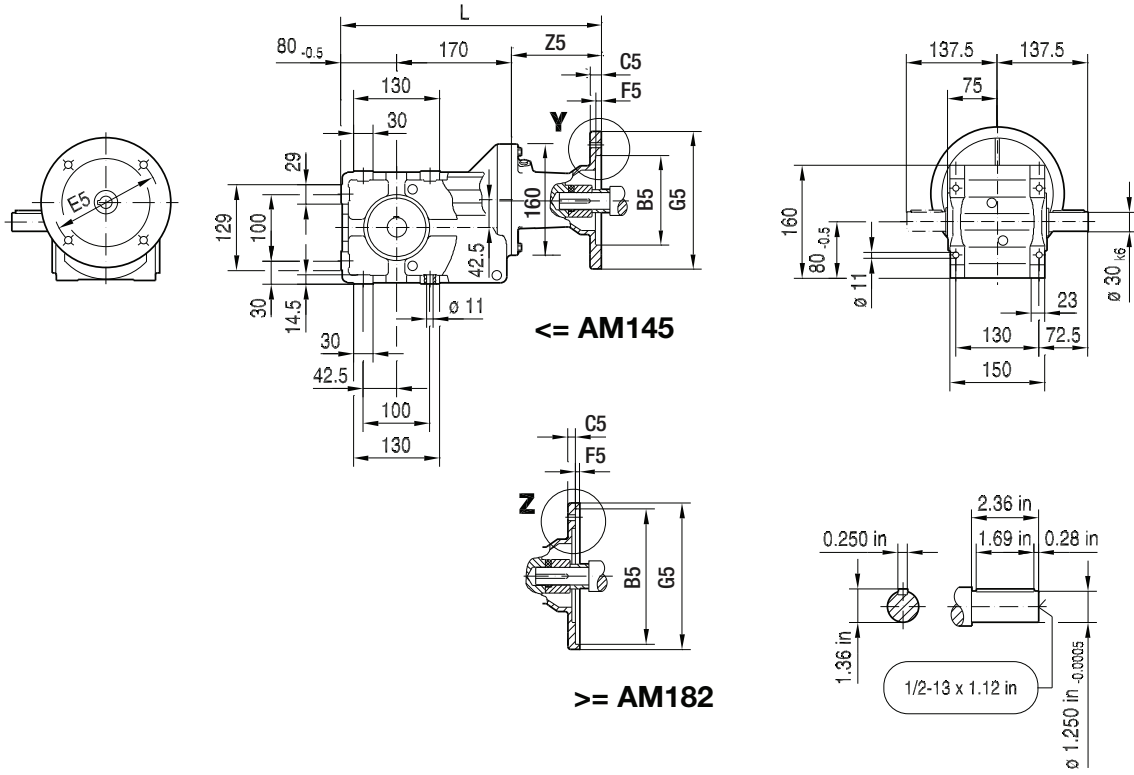

(→ 132)	B	B5	C5	E5	F5	G5	L	L1	L5	S5	T1	U	U1	Z5
AM56	1.23 in	4.50 in	11	5.875 in	4.5	170	337	1.88 in	-0.18 in	10.5	0.71 in	0.625 in	0.188 in	87
AM143	1.68 in	4.50 in	12	5.875 in	4.5	170	360.5	2.25 in	0.13 in	10.5	0.98 in	0.875 in	0.188 in	110.5
AM145	1.68 in	4.50 in	12	5.875 in	4.5	170	360.5	2.25 in	0.13 in	10.5	0.98 in	0.875 in	0.188 in	110.5
AM182	2.10 in	8.50 in	10	7.25 in	5	228	397.5	2.75 in	0.13 in	15	1.24 in	1.125 in	0.250 in	147.5
AM184	2.10 in	8.50 in	10	7.25 in	5	228	397.5	2.75 in	0.13 in	15	1.24 in	1.125 in	0.250 in	147.5

Note: Dimensions in mm unless otherwise noted. For all available output shaft diameters, see page 573.

10 K - Helical Bevel

K.. AM.. [NEMA dimensions]

33 053 00 15US

KF39..

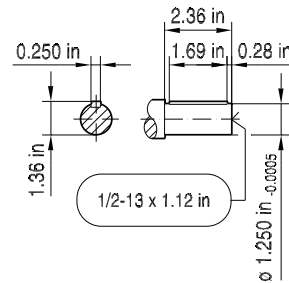
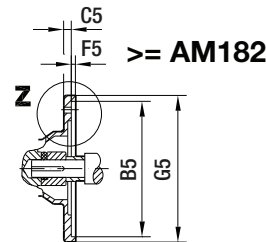
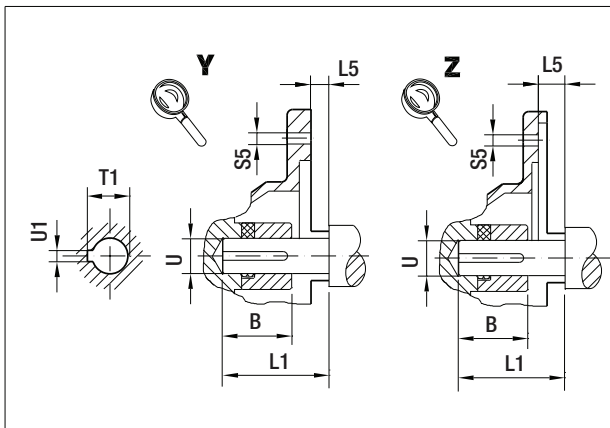
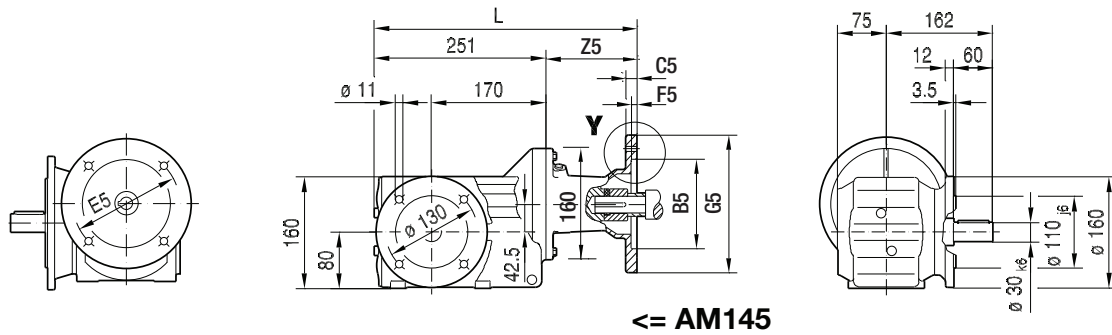

KAF39..

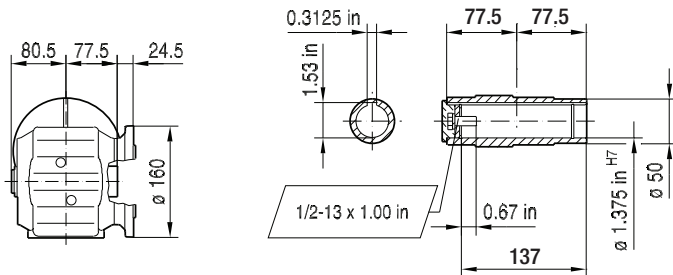

(→ 132)	B	B5	C5	E5	F5	G5	L	L1	L5	S5	T1	U	U1	Z5
AM56	1.23 in	4.50 in	11	5.875 in	4.5	170	338	1.88 in	-0.18 in	10.5	0.71 in	0.625 in	0.188 in	87
AM143	1.68 in	4.50 in	12	5.875 in	4.5	170	361.5	2.25 in	0.13 in	10.5	0.98 in	0.875 in	0.188 in	110.5
AM145	1.68 in	4.50 in	12	5.875 in	4.5	170	361.5	2.25 in	0.13 in	10.5	0.98 in	0.875 in	0.188 in	110.5
AM182	2.10 in	8.50 in	10	7.25 in	5	228	398.5	2.75 in	0.13 in	15	1.24 in	1.125 in	0.250 in	147.5
AM184	2.10 in	8.50 in	10	7.25 in	5	228	398.5	2.75 in	0.13 in	15	1.24 in	1.125 in	0.250 in	147.5

Note: Dimensions in mm unless otherwise noted. For all available output shaft diameters, see page 573.

KA39..

33 054 00 15US

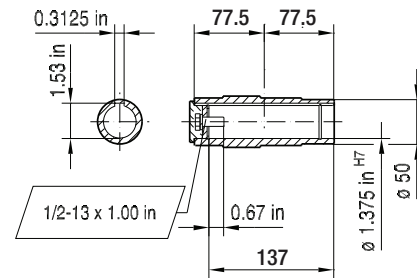
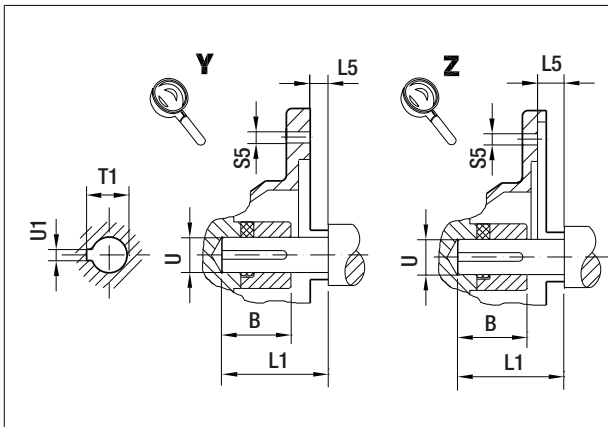
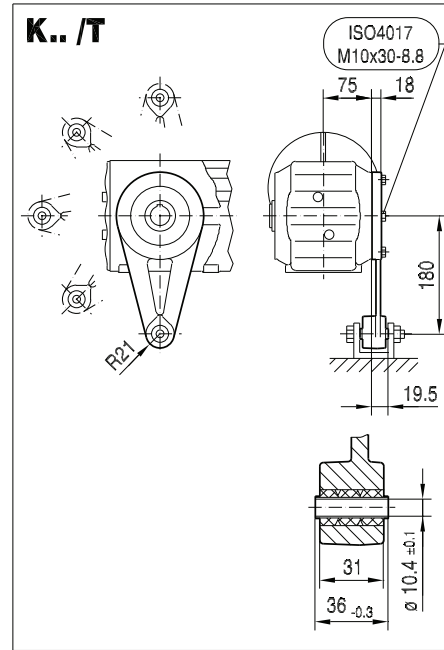
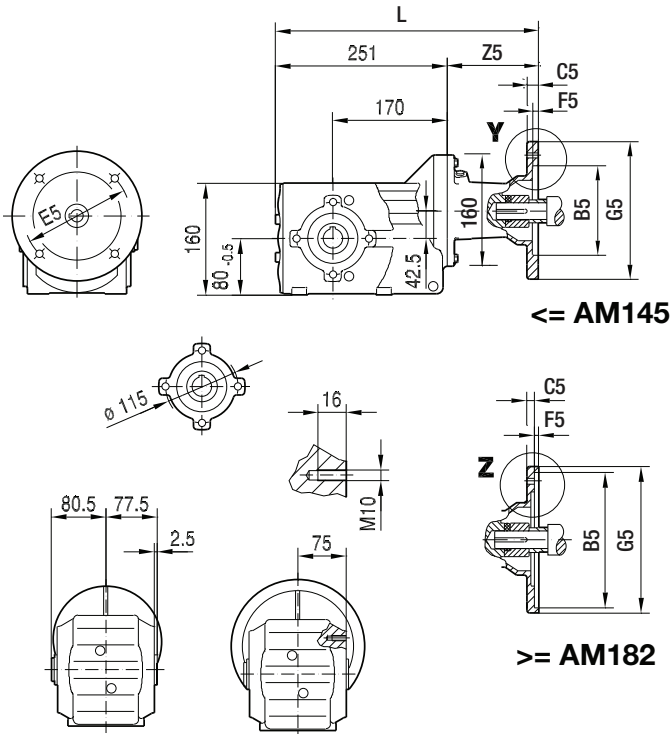

(→ 132)	B	B5	C5	E5	F5	G5	L	L1	L5	S5	T1	U	U1	Z5
AM56	1.23 in	4.50 in	11	5.875 in	4.5	170	338	1.88 in	-0.18 in	10.5	0.71 in	0.625 in	0.188 in	87
AM143	1.68 in	4.50 in	12	5.875 in	4.5	170	361.5	2.25 in	0.13 in	10.5	0.98 in	0.875 in	0.188 in	110.5
AM145	1.68 in	4.50 in	12	5.875 in	4.5	170	361.5	2.25 in	0.13 in	10.5	0.98 in	0.875 in	0.188 in	110.5
AM182	2.10 in	8.50 in	10	7.25 in	5	228	398.5	2.75 in	0.13 in	15	1.24 in	1.125 in	0.250 in	147.5
AM184	2.10 in	8.50 in	10	7.25 in	5	228	398.5	2.75 in	0.13 in	15	1.24 in	1.125 in	0.250 in	147.5

Note: Dimensions in mm unless otherwise noted. For all available output shaft diameters, see page 575.

10 K - Helical Bevel

K.. AM.. [NEMA dimensions]

KT39..

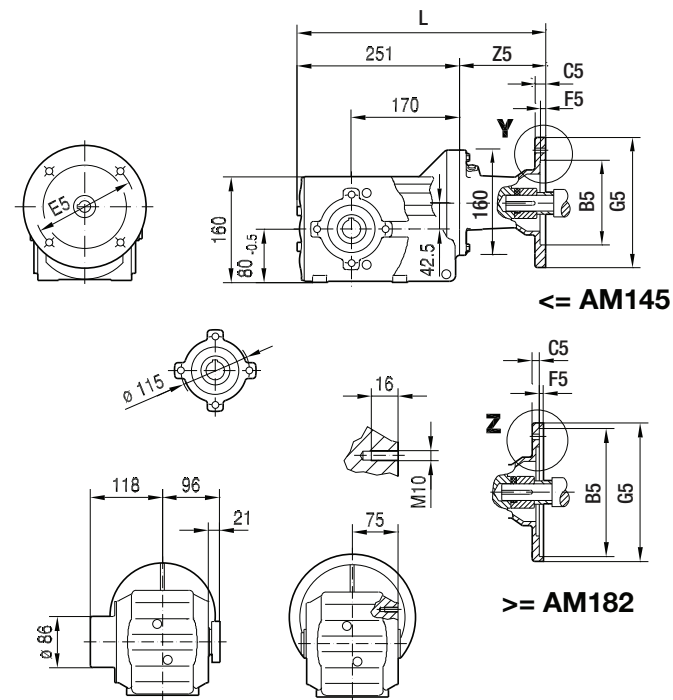

≤ AM145

≥ AM182

without shaft shoulder

with shaft shoulder

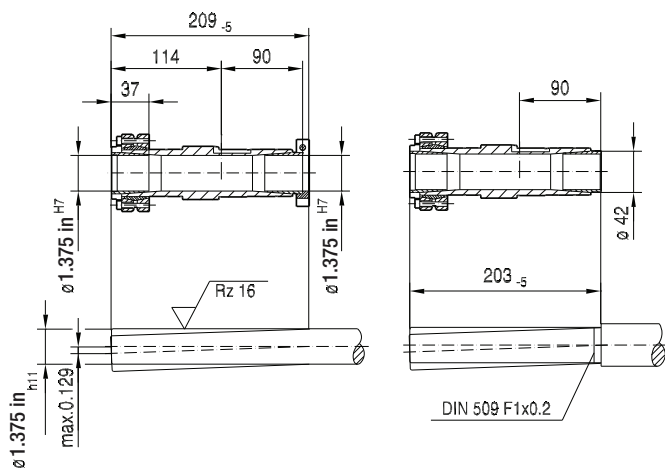

DIN 509 F1x0.2

33 055 00 15US

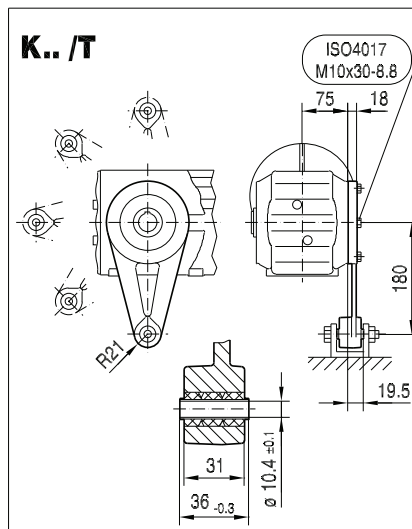

K.. / T

ISO4017
M10x30-8.8

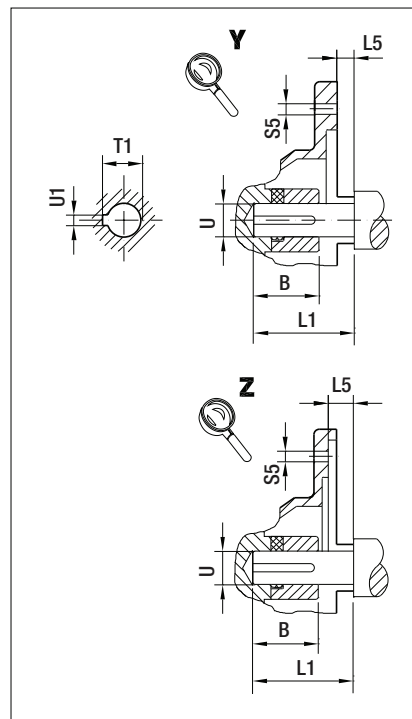

(→ 132)	B	B5	C5	E5	F5	G5	L	L1	L5	S5	T1	U	U1	Z5
AM56	1.23 in	4.50 in	11	5.875 in	4.5	170	338	1.88 in	-0.18 in	10.5	0.71 in	0.625 in	0.188 in	87
AM143	1.68 in	4.50 in	12	5.875 in	4.5	170	361.5	2.25 in	0.13 in	10.5	0.98 in	0.875 in	0.188 in	110.5
AM145	1.68 in	4.50 in	12	5.875 in	4.5	170	361.5	2.25 in	0.13 in	10.5	0.98 in	0.875 in	0.188 in	110.5
AM182	2.10 in	8.50 in	10	7.25 in	5	228	398.5	2.75 in	0.13 in	15	1.24 in	1.125 in	0.250 in	147.5
AM184	2.10 in	8.50 in	10	7.25 in	5	228	398.5	2.75 in	0.13 in	15	1.24 in	1.125 in	0.250 in	147.5

Note: Dimensions in mm unless otherwise noted. For all available output shaft diameters, see page 577.

33 013 00 11

K47..

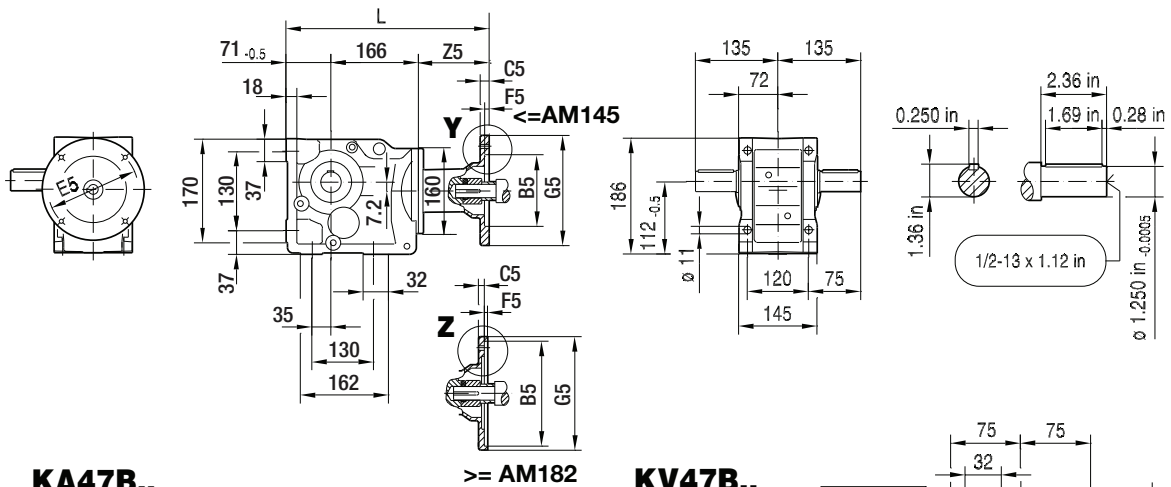

KA47B..

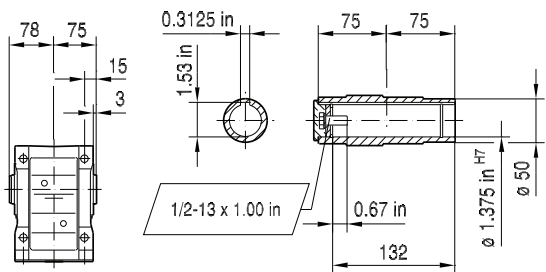

KV47B..

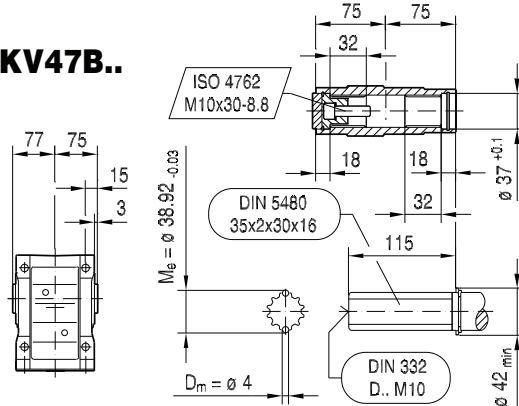

KH47B..

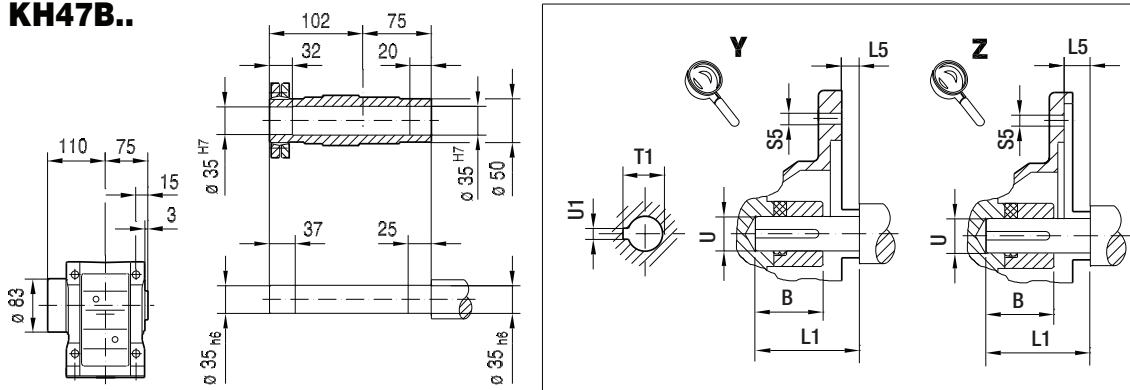

(→ 132)	B	B5	C5	E5	F5	G5	L	L1	L5	S5	T1	U	U1	Z5
AM56	1.23 in	4.50 in	11	5.875 in	4.5	170	324	1.88 in	-0.18 in	10.5	0.71 in	0.625 in	0.188 in	87
AM143	1.68 in	4.50 in	12	5.875 in	4.5	170	348	2.25 in	0.13 in	10.5	0.98 in	0.875 in	0.188 in	110.5
AM145	1.68 in	4.50 in	12	5.875 in	4.5	170	348	2.25 in	0.13 in	10.5	0.98 in	0.875 in	0.188 in	110.5
AM182	2.10 in	8.50 in	10	7.25 in	5	228	385	2.75 in	0.13 in	15	1.24 in	1.125 in	0.250 in	147.5
AM184	2.10 in	8.50 in	10	7.25 in	5	228	385	2.75 in	0.13 in	15	1.24 in	1.125 in	0.250 in	147.5

Note: Dimensions in mm unless otherwise noted. For all available output shaft diameters, see page 573. For dimensions of compound gear units (ex: K47R37) see page 565.

33 014 00 11

KF47..

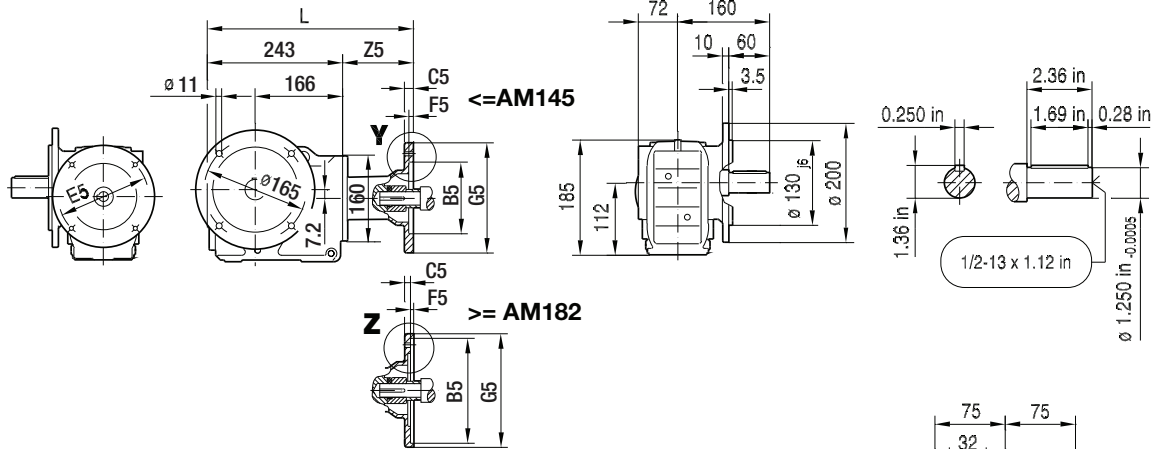

KAF47..

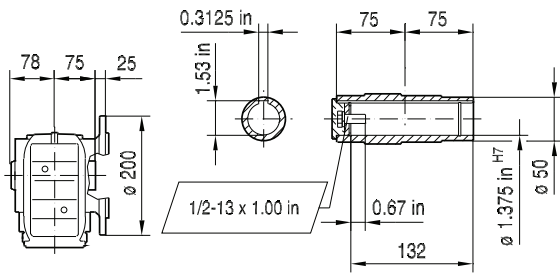

KVF47..

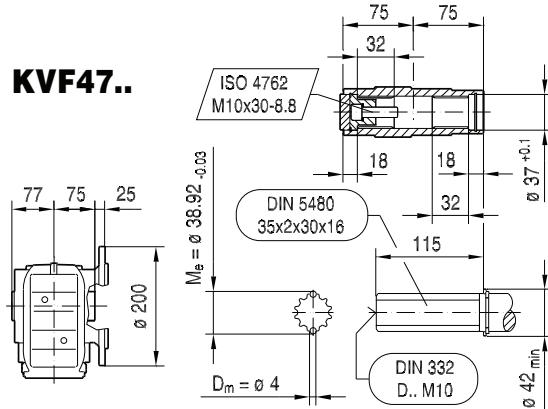

KHF47..

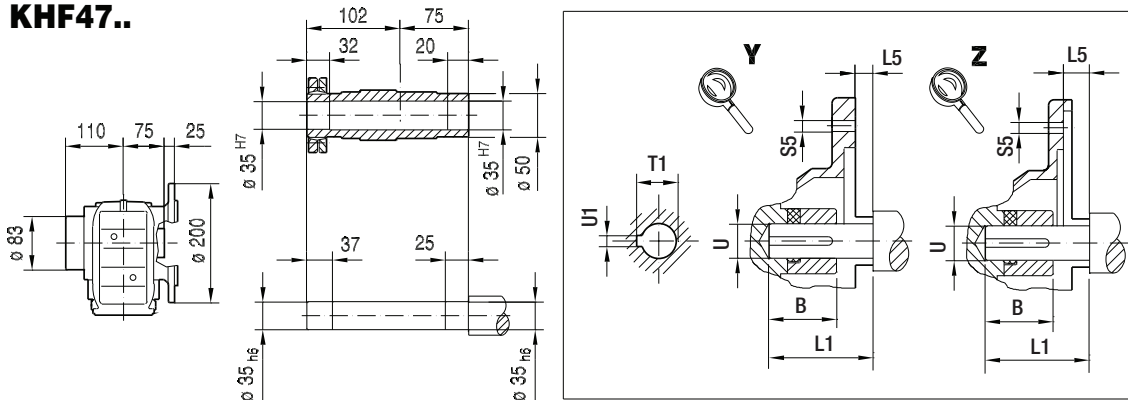

(→  132)	B	B5	C5	E5	F5	G5	L	L1	L5	S5	T1	U	U1	Z5
AM56	1.23 in	4.50 in	11	5.875 in	4.5	170	330	1.88 in	-0.18 in	10.5	0.71 in	0.625 in	0.188 in	87
AM143	1.68 in	4.50 in	12	5.875 in	4.5	170	354	2.25 in	0.13 in	10.5	0.98 in	0.875 in	0.188 in	110.5
AM145	1.68 in	4.50 in	12	5.875 in	4.5	170	354	2.25 in	0.13 in	10.5	0.98 in	0.875 in	0.188 in	110.5
AM182	2.10 in	8.50 in	10	7.25 in	5	228	391	2.75 in	0.13 in	15	1.24 in	1.125 in	0.250 in	147.5
AM184	2.10 in	8.50 in	10	7.25 in	5	228	391	2.75 in	0.13 in	15	1.24 in	1.125 in	0.250 in	147.5

Note: Dimensions in mm unless otherwise noted. For all available output shaft diameters, see page 573. For dimensions of compound gear units (ex: KF47R37) see page 565.

KA47..

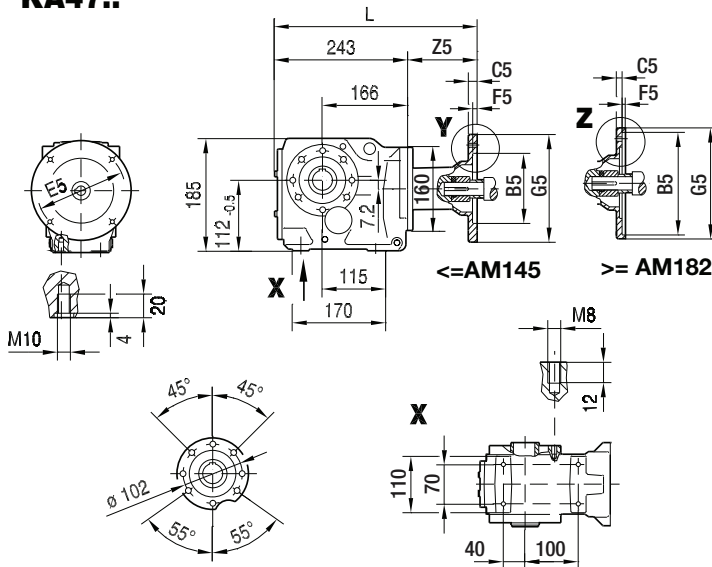

33 015 00 11

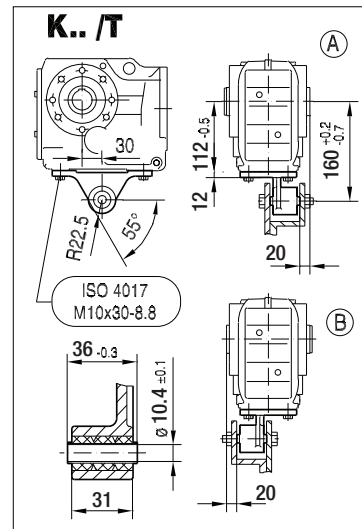

KA47..

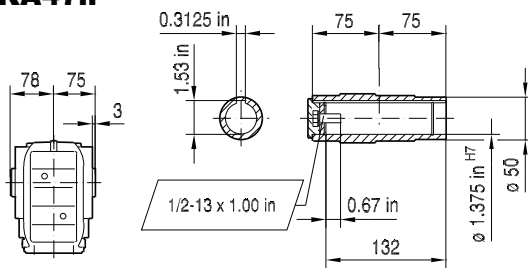

KV47..

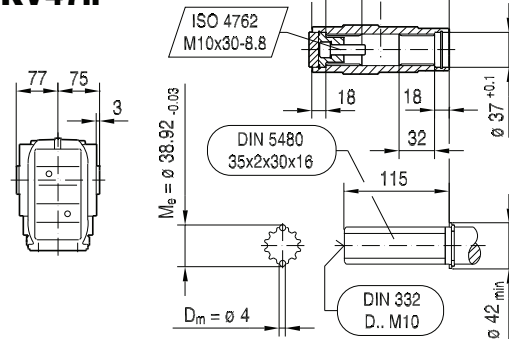

KH47..

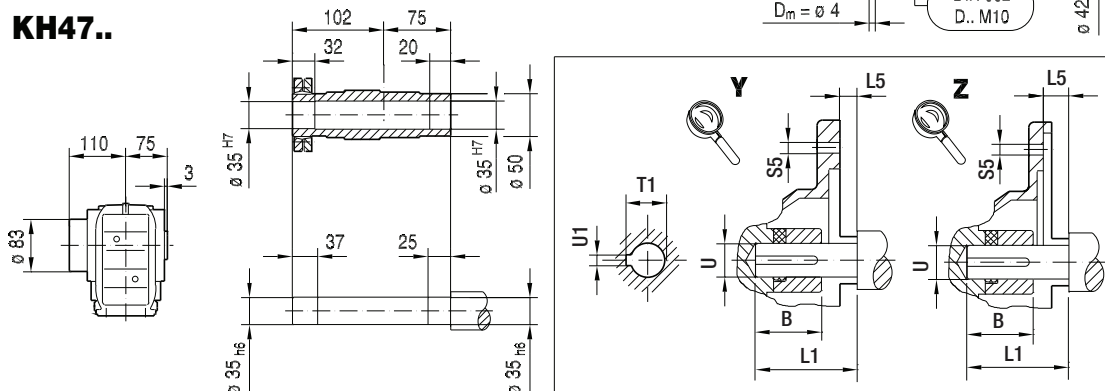

(→ 132)	B	B5	C5	E5	F5	G5	L	L1	L5	S5	T1	U	U1	Z5
AM56	1.23 in	4.50 in	11	5.875 in	4.5	170	330	1.88 in	-0.18 in	10.5	0.71 in	0.625 in	0.188 in	87
AM143	1.68 in	4.50 in	12	5.875 in	4.5	170	354	2.25 in	0.13 in	10.5	0.98 in	0.875 in	0.188 in	110.5
AM145	1.68 in	4.50 in	12	5.875 in	4.5	170	354	2.25 in	0.13 in	10.5	0.98 in	0.875 in	0.188 in	110.5
AM182	2.10 in	8.50 in	10	7.25 in	5	228	391	2.75 in	0.13 in	15	1.24 in	1.125 in	0.250 in	147.5
AM184	2.10 in	8.50 in	10	7.25 in	5	228	391	2.75 in	0.13 in	15	1.24 in	1.125 in	0.250 in	147.5

Note: Dimensions in mm unless otherwise noted. For all available output shaft diameters, see page 573. For dimensions of compound gear units (ex: KA47R37) see page 565.

33 016 00 11

KAZ47..

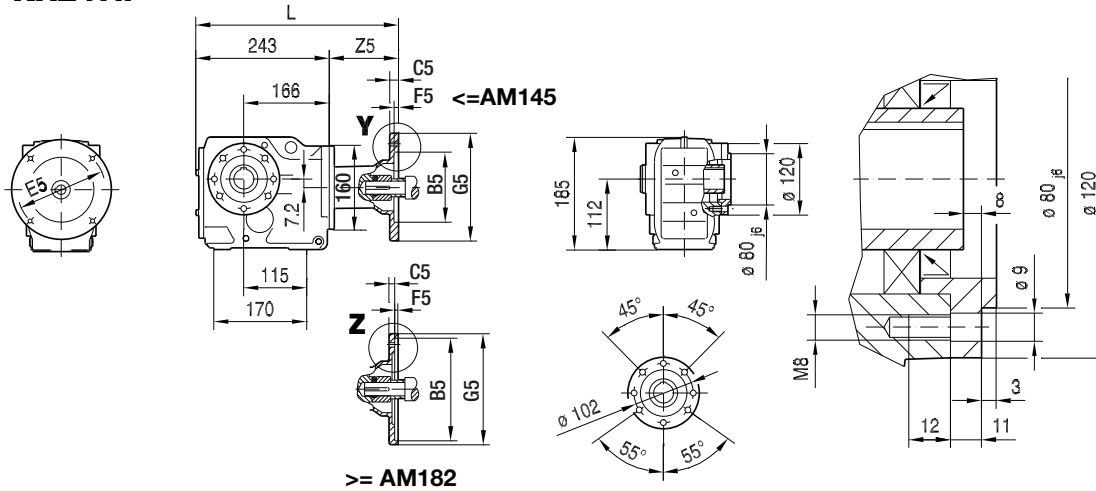

KAZ47..

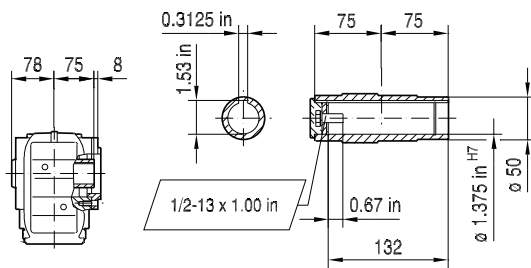

KVZ47..

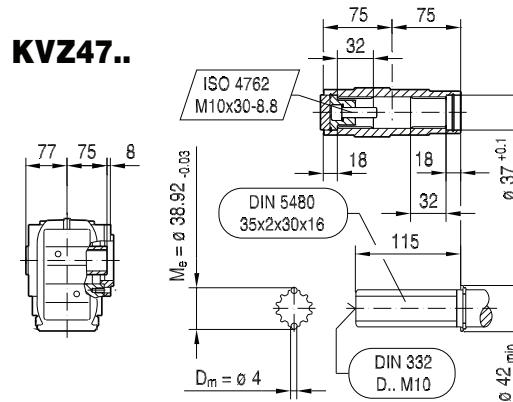

KHZ47..

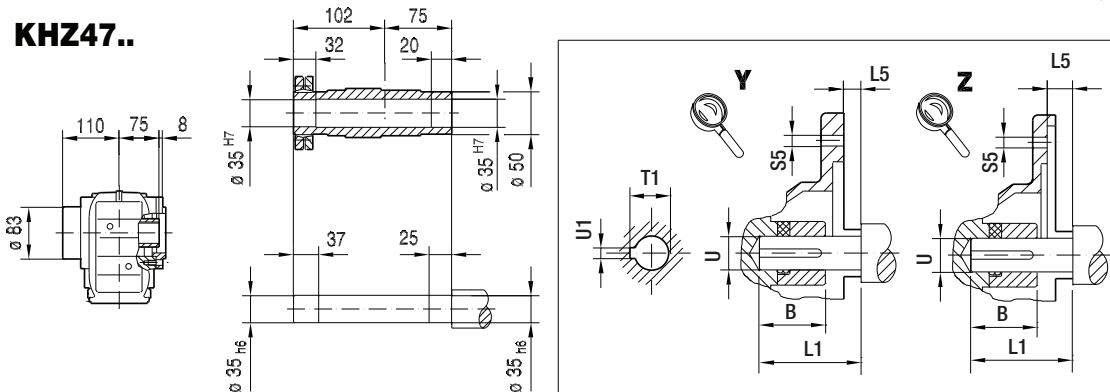

(\rightarrow 132)	B	B5	C5	E5	F5	G5	L	L1	L5	S5	T1	U	U1	Z5
AM56	1.23 in	4.50 in	11	5.875 in	4.5	170	330	1.88 in	-0.18 in	10.5	0.71 in	0.625 in	0.188 in	87
AM143	1.68 in	4.50 in	12	5.875 in	4.5	170	354	2.25 in	0.13 in	10.5	0.98 in	0.875 in	0.188 in	110.5
AM145	1.68 in	4.50 in	12	5.875 in	4.5	170	354	2.25 in	0.13 in	10.5	0.98 in	0.875 in	0.188 in	110.5
AM182	2.10 in	8.50 in	10	7.25 in	5	228	391	2.75 in	0.13 in	15	1.24 in	1.125 in	0.250 in	147.5
AM184	2.10 in	8.50 in	10	7.25 in	5	228	391	2.75 in	0.13 in	15	1.24 in	1.125 in	0.250 in	147.5

Note: Dimensions in mm unless otherwise noted. For all available output shaft diameters, see page 575. For dimensions of compound gear units (ex: KAZ47R37) see page 565.

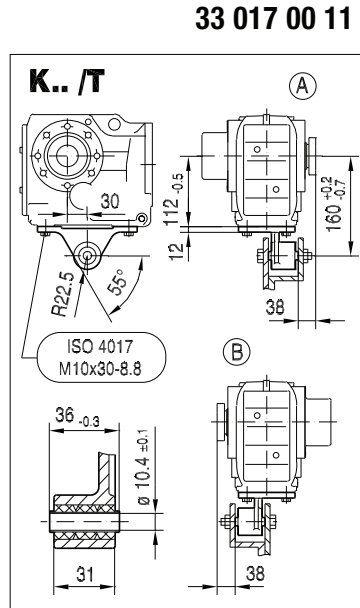
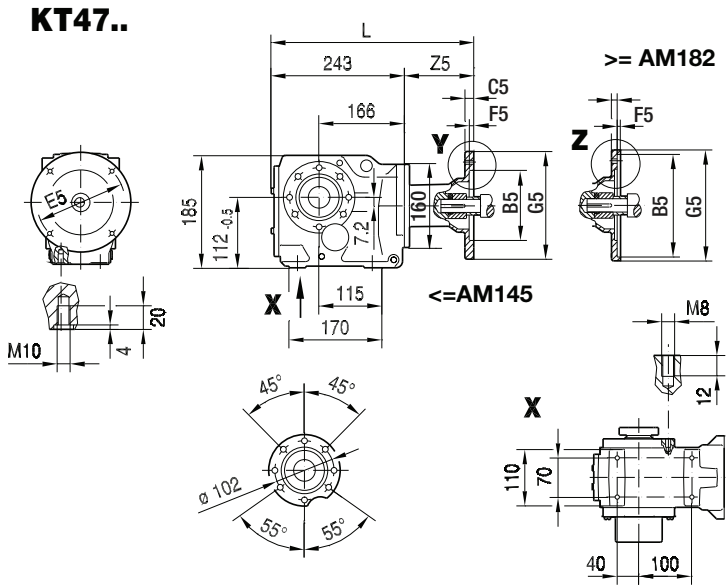

NON-Symmetrical

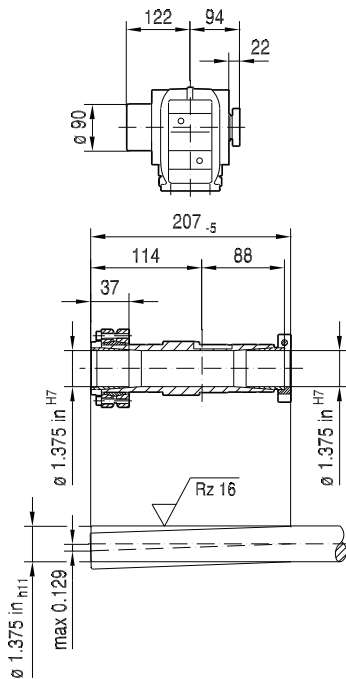

Symmetrical

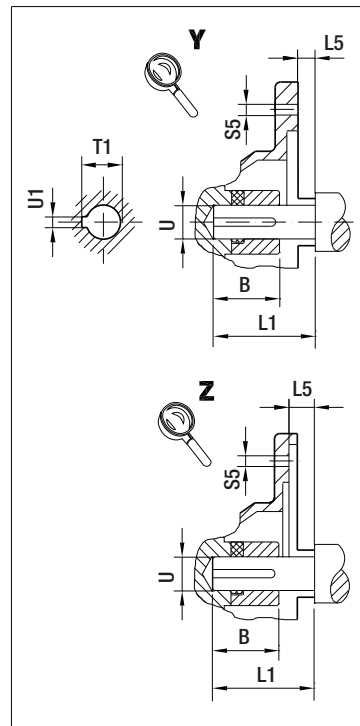
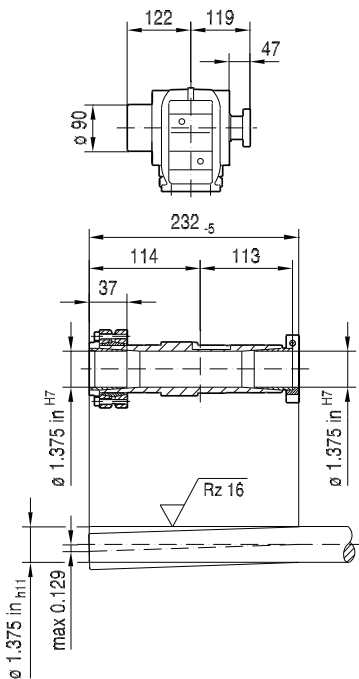

(→ 132)	B	B5	C5	E5	F5	G5	L	L1	L5	S5	T1	U	U1	Z5
AM56	1.23 in	4.50 in	11	5.875 in	4.5	170	330	1.88 in	-0.18 in	10.5	0.71 in	0.625 in	0.188 in	87
AM143	1.68 in	4.50 in	12	5.875 in	4.5	170	354	2.25 in	0.13 in	10.5	0.98 in	0.875 in	0.188 in	110.5
AM145	1.68 in	4.50 in	12	5.875 in	4.5	170	354	2.25 in	0.13 in	10.5	0.98 in	0.875 in	0.188 in	110.5
AM182	2.10 in	8.50 in	10	7.25 in	5	228	391	2.75 in	0.13 in	15	1.24 in	1.125 in	0.250 in	147.5
AM184	2.10 in	8.50 in	10	7.25 in	5	228	391	2.75 in	0.13 in	15	1.24 in	1.125 in	0.250 in	147.5

Note: Dimensions in mm unless otherwise noted. For all available output shaft diameters, see page 577. For dimensions of compound gear units (ex: KT47R37) see page 565.

10 K - Helical Bevel

K.. AM.. [NEMA dimensions]

33 056 00 15US

K49..

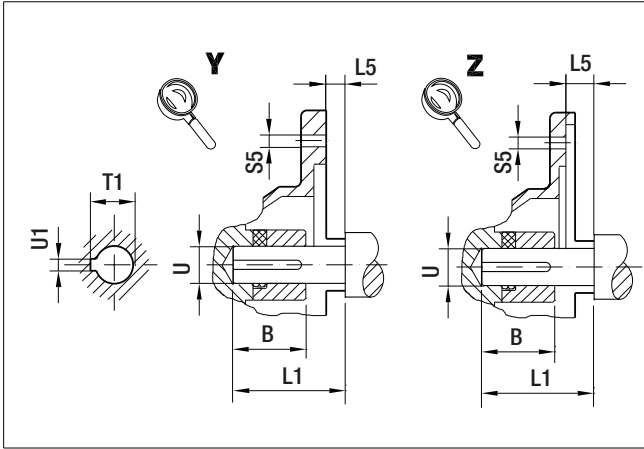
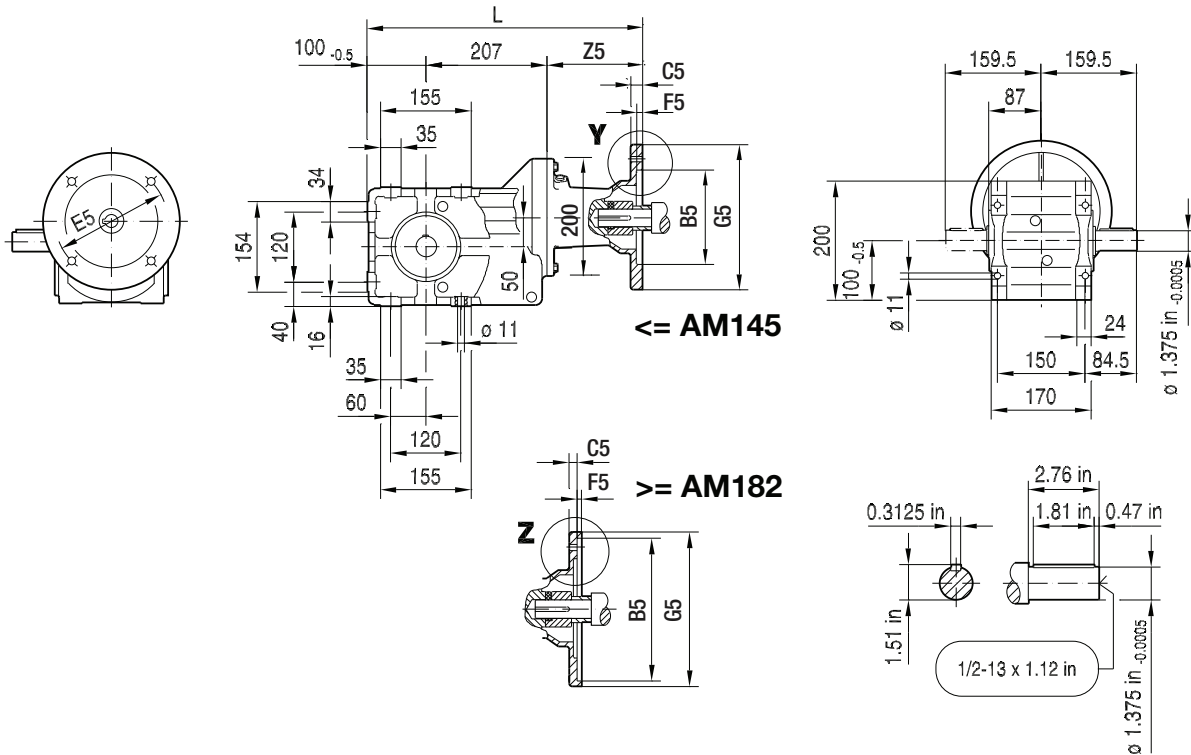

(→ 132)	B	B5	C5	E5	F5	G5	L	L1	L5	S5	T1	U	U1	Z5
AM56	1.23 in	4.50 in	11	5.875 in	4.5	170	388	1.88 in	-0.18 in	10.5	0.71 in	0.625 in	0.188 in	81
AM143	1.68 in	4.50 in	12	5.875 in	4.5	170	410.5	2.25 in	0.13 in	10.5	0.98 in	0.875 in	0.188 in	103.5
AM145	1.68 in	4.50 in	12	5.875 in	4.5	170	410.5	2.25 in	0.13 in	10.5	0.98 in	0.875 in	0.188 in	103.5
AM182	2.10 in	8.50 in	10	7.25 in	5	228	446.5	2.75 in	0.13 in	15	1.24 in	1.125 in	0.250 in	139.5
AM184	2.10 in	8.50 in	10	7.25 in	5	228	446.5	2.75 in	0.13 in	15	1.24 in	1.125 in	0.250 in	139.5
AM213/215	2.76 in	8.50 in	11	7.25 in	5	228	495.5	3.38 in	0.25 in	15	1.52 in	1.375 in	0.312 in	188.5

Note: Dimensions in mm unless otherwise noted. For all available output shaft diameters, see page 573. For dimensions of compound gear units (ex: K49R37) see page 565.

KF49..

33 057 00 15US

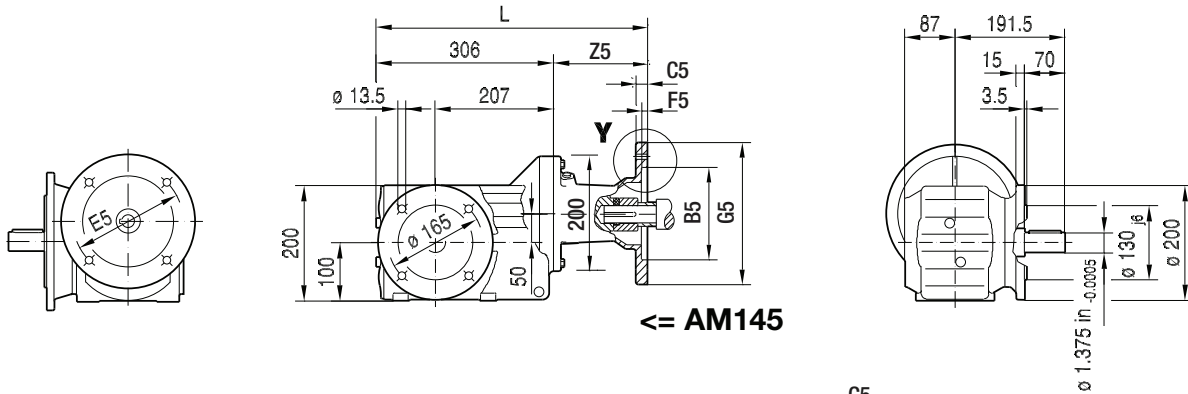

←= AM145

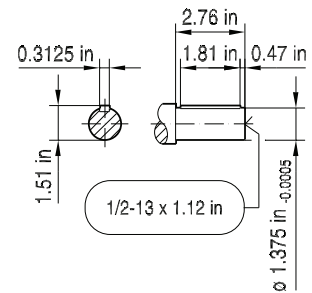
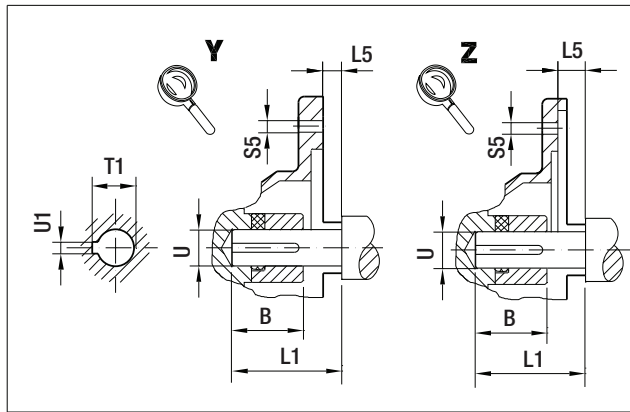

10

KAF49..

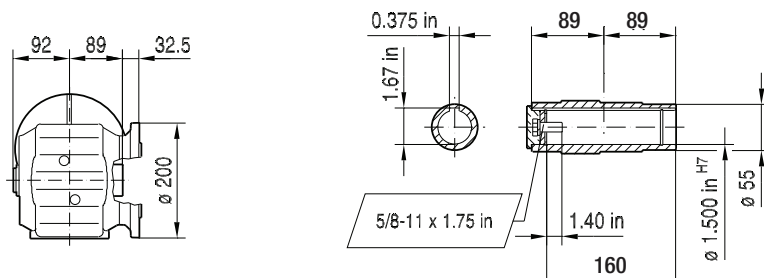

(→ 132)	B	B5	C5	E5	F5	G5	L	L1	L5	S5	T1	U	U1	Z5
AM56	1.23 in	4.50 in	11	5.875 in	4.5	170	387	1.88 in	-0.18 in	10.5	0.71 in	0.625 in	0.188 in	81
AM143	1.68 in	4.50 in	12	5.875 in	4.5	170	409.5	2.25 in	0.13 in	10.5	0.98 in	0.875 in	0.188 in	103.5
AM145	1.68 in	4.50 in	12	5.875 in	4.5	170	409.5	2.25 in	0.13 in	10.5	0.98 in	0.875 in	0.188 in	103.5
AM182	2.10 in	8.50 in	10	7.25 in	5	228	445.5	2.75 in	0.13 in	15	1.24 in	1.125 in	0.250 in	139.5
AM184	2.10 in	8.50 in	10	7.25 in	5	228	445.5	2.75 in	0.13 in	15	1.24 in	1.125 in	0.250 in	139.5
AM213/215	2.76 in	8.50 in	11	7.25 in	5	228	494.5	3.38 in	0.25 in	15	1.52 in	1.375 in	0.312 in	188.5

Note: Dimensions in mm unless otherwise noted. For all available output shaft diameters, see page 573. For dimensions of compound gear units (ex: KF49R37) see page 565.

10 K - Helical Bevel

K.. AM.. [NEMA dimensions]

KA49..

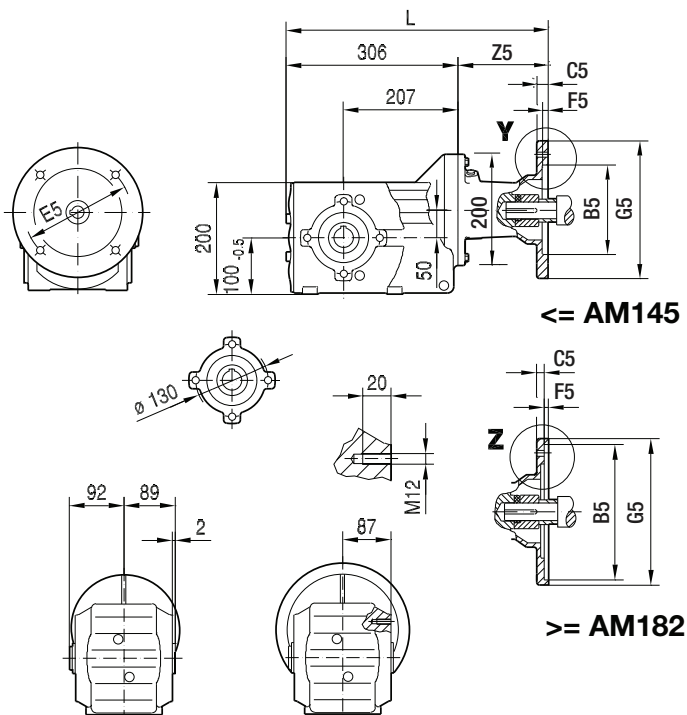

33 058 00 15US

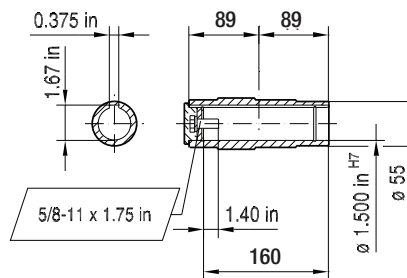
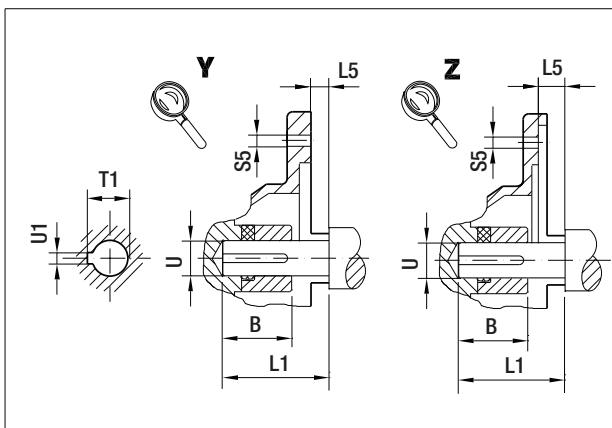
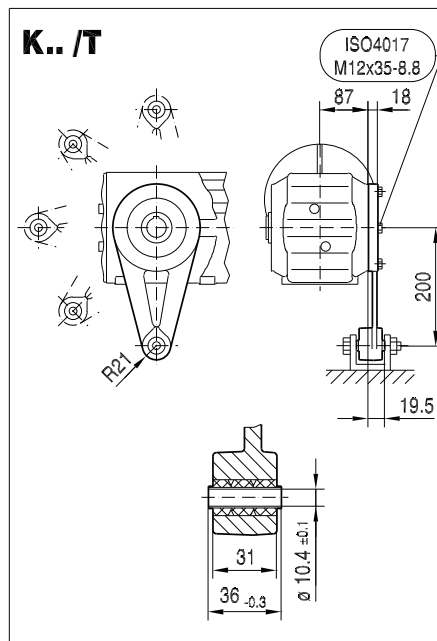

(→ 132)	B	B5	C5	E5	F5	G5	L	L1	L5	S5	T1	U	U1	Z5
AM56	1.23 in	4.50 in	11	5.875 in	4.5	170	387	1.88 in	-0.18 in	10.5	0.71 in	0.625 in	0.188 in	81
AM143	1.68 in	4.50 in	12	5.875 in	4.5	170	409.5	2.25 in	0.13 in	10.5	0.98 in	0.875 in	0.188 in	103.5
AM145	1.68 in	4.50 in	12	5.875 in	4.5	170	409.5	2.25 in	0.13 in	10.5	0.98 in	0.875 in	0.188 in	103.5
AM182	2.10 in	8.50 in	10	7.25 in	5	228	445.5	2.75 in	0.13 in	15	1.24 in	1.125 in	0.250 in	139.5
AM184	2.10 in	8.50 in	10	7.25 in	5	228	445.5	2.75 in	0.13 in	15	1.24 in	1.125 in	0.250 in	139.5
AM213/215	2.76 in	8.50 in	11	7.25 in	5	228	494.5	3.38 in	0.25 in	15	1.52 in	1.375 in	0.312 in	188.5

Note: Dimensions in mm unless otherwise noted. For all available output shaft diameters, see page 575. For dimensions of compound gear units (ex: KA49R37) see page 565.

KT49..

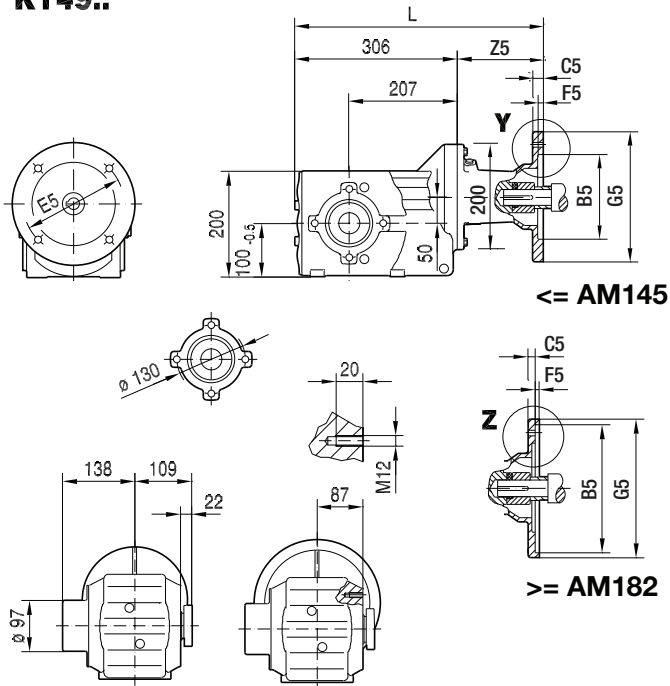

← AM145

≥ AM182

without shaft shoulder

with shaft shoulder

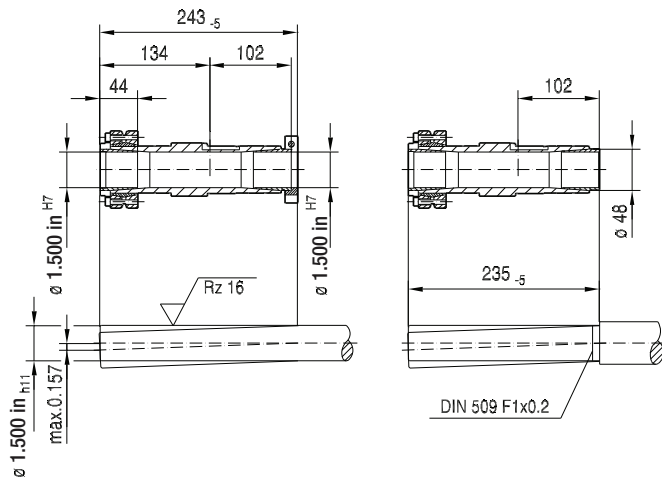

33 059 00 15US

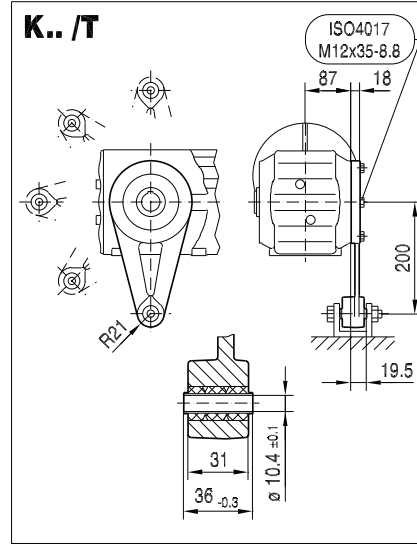

K.. / T

ISO4017
M12x35-8.8

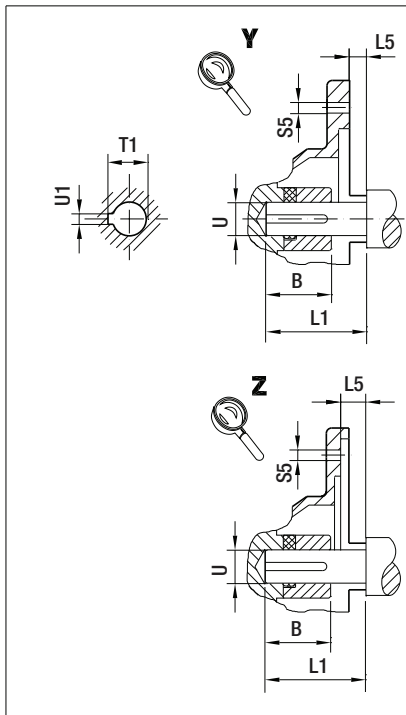

(→ 132)	B	B5	C5	E5	F5	G5	L	L1	L5	S5	T1	U	U1	Z5
AM56	1.23 in	4.50 in	11	5.875 in	4.5	170	387	1.88 in	-0.18 in	10.5	0.71 in	0.625 in	0.188 in	81
AM143	1.68 in	4.50 in	12	5.875 in	4.5	170	409.5	2.25 in	0.13 in	10.5	0.98 in	0.875 in	0.188 in	103.5
AM145	1.68 in	4.50 in	12	5.875 in	4.5	170	409.5	2.25 in	0.13 in	10.5	0.98 in	0.875 in	0.188 in	103.5
AM182	2.10 in	8.50 in	10	7.25 in	5	228	445.5	2.75 in	0.13 in	15	1.24 in	1.125 in	0.250 in	139.5
AM184	2.10 in	8.50 in	10	7.25 in	5	228	445.5	2.75 in	0.13 in	15	1.24 in	1.125 in	0.250 in	139.5
AM213/215	2.76 in	8.50 in	11	7.25 in	5	228	494.5	3.38 in	0.25 in	15	1.52 in	1.375 in	0.312 in	188.5

Note: Dimensions in mm unless otherwise noted. For all available output shaft diameters, see page 577. For dimensions of compound gear units (ex: KT49R37) see page 565.

10 K - Helical Bevel

K.. AM.. [NEMA dimensions]

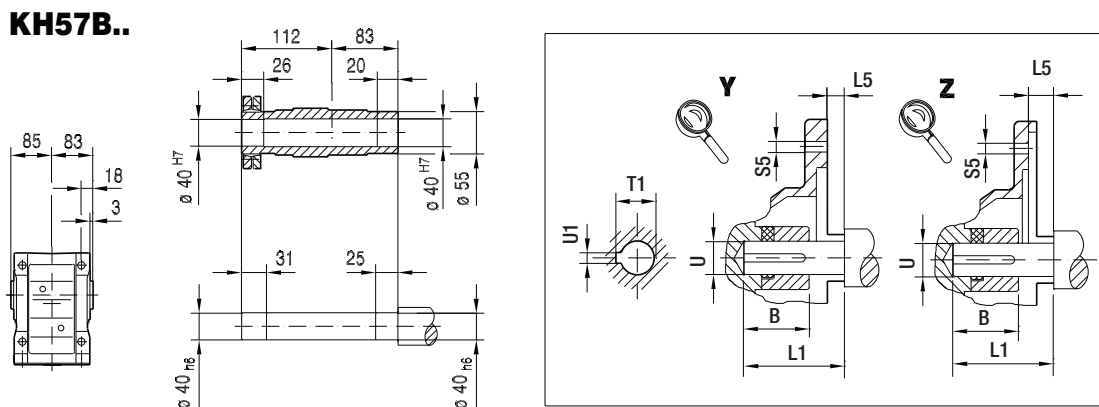
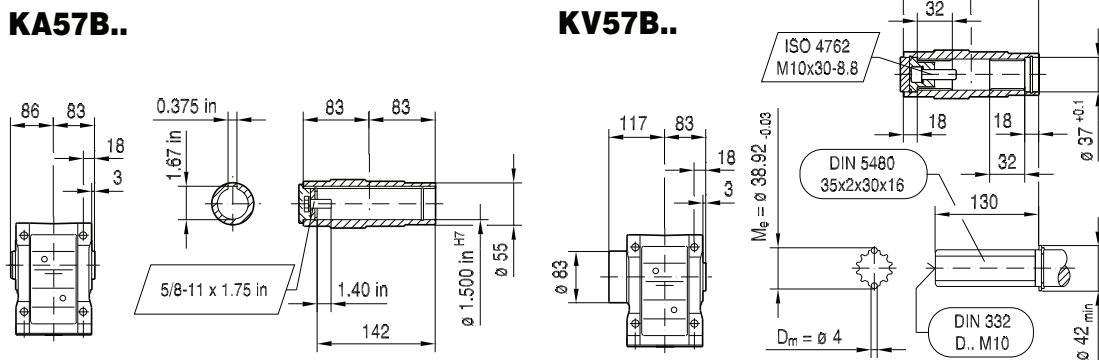
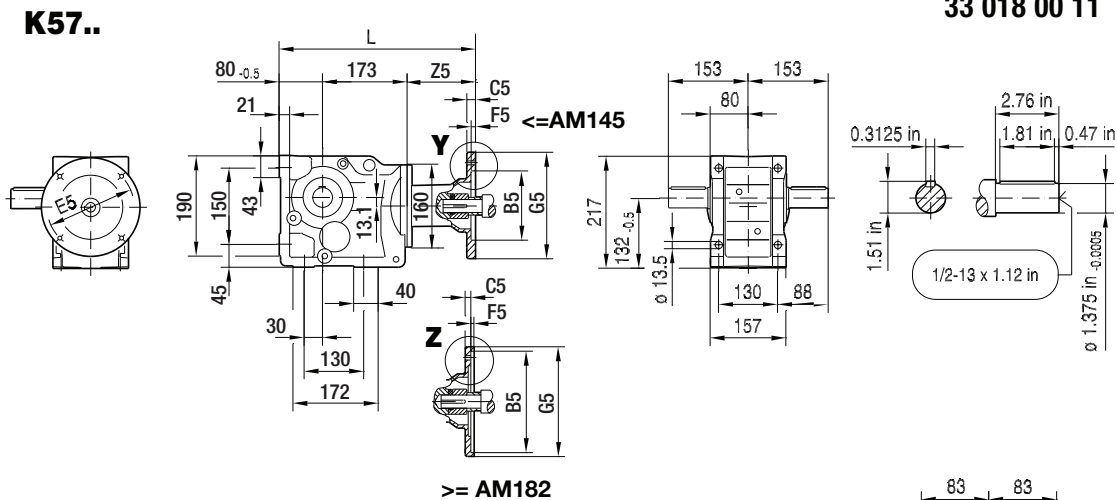

(→ 132)	B	B5	C5	E5	F5	G5	L	L1	L5	S5	T1	U	U1	Z5
AM56	1.23 in	4.50 in	11	5.875 in	4.5	170	340	1.88 in	-0.18 in	10.5	0.71 in	0.625 in	0.188 in	87
AM143	1.68 in	4.50 in	12	5.875 in	4.5	170	364	2.25 in	0.13 in	10.5	0.98 in	0.875 in	0.188 in	110.5
AM145	1.68 in	4.50 in	12	5.875 in	4.5	170	364	2.25 in	0.13 in	10.5	0.98 in	0.875 in	0.188 in	110.5
AM182	2.10 in	8.50 in	10	7.25 in	5	228	401	2.75 in	0.13 in	15	1.24 in	1.125 in	0.250 in	147.5
AM184	2.10 in	8.50 in	10	7.25 in	5	228	401	2.75 in	0.13 in	15	1.24 in	1.125 in	0.250 in	147.5
AM213/215	2.76 in	8.50 in	11	7.25 in	5	228	454	3.38 in	0.25 in	15	1.52 in	1.375 in	0.312 in	200.5

Note: Dimensions in mm unless otherwise noted. For all available output shaft diameters, see page 573. For dimensions of compound gear units (ex: K57R37) see page 565.

33 019 00 11

KF57..

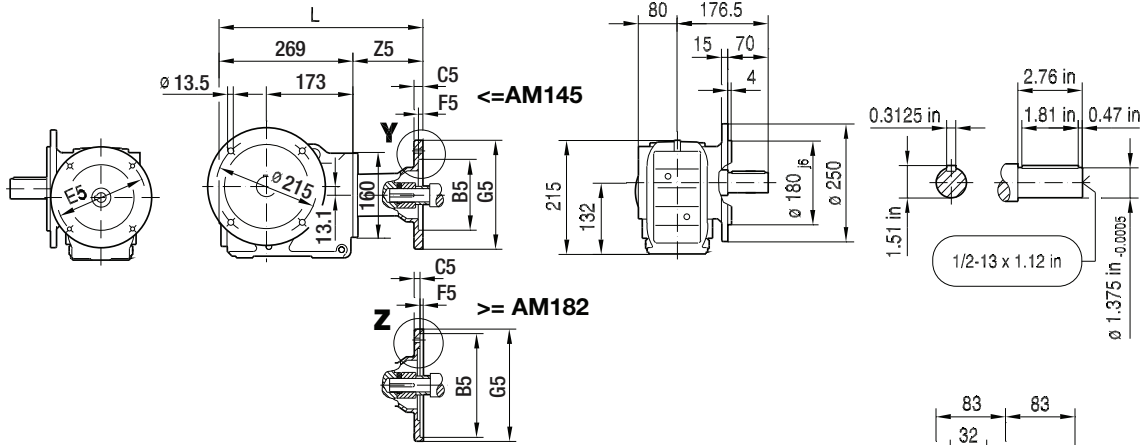

KAF57..

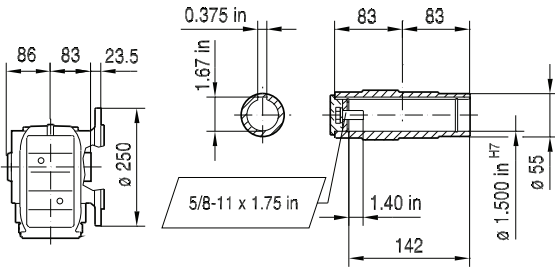

KVF57..

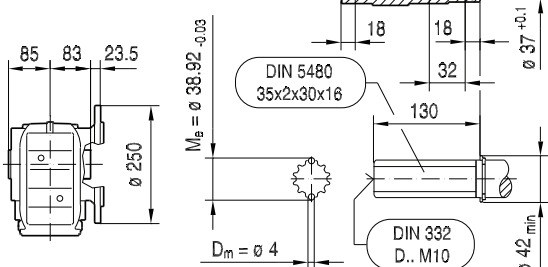

KHF57..

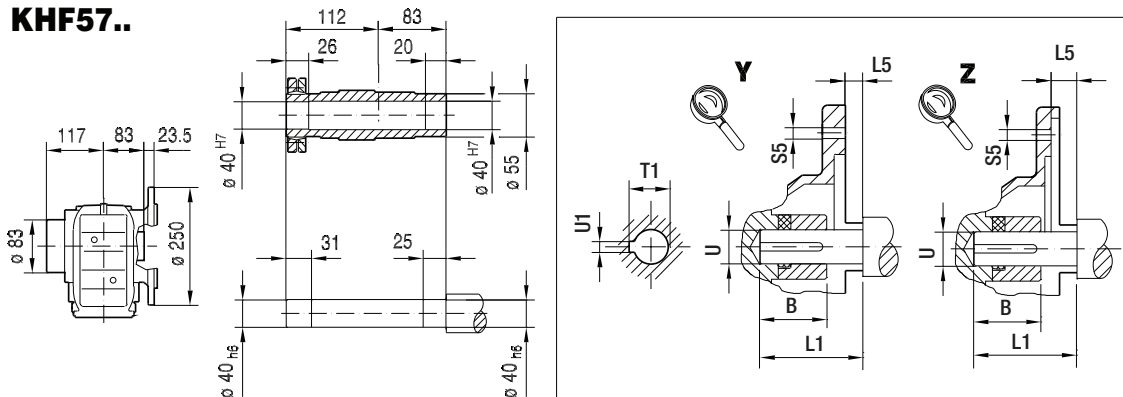

(→ 132)	B	B5	C5	E5	F5	G5	L	L1	L5	S5	T1	U	U1	Z5
AM56	1.23 in	4.50 in	11	5.875 in	4.5	170	356	1.88 in	-0.18 in	10.5	0.71 in	0.625 in	0.188 in	87
AM143	1.68 in	4.50 in	12	5.875 in	4.5	170	380	2.25 in	0.13 in	10.5	0.98 in	0.875 in	0.188 in	110.5
AM145	1.68 in	4.50 in	12	5.875 in	4.5	170	380	2.25 in	0.13 in	10.5	0.98 in	0.875 in	0.188 in	110.5
AM182	2.10 in	8.50 in	10	7.25 in	5	228	417	2.75 in	0.13 in	15	1.24 in	1.125 in	0.250 in	147.5
AM184	2.10 in	8.50 in	10	7.25 in	5	228	417	2.75 in	0.13 in	15	1.24 in	1.125 in	0.250 in	147.5
AM213/215	2.76 in	8.50 in	11	7.25 in	5	228	470	3.38 in	0.25 in	15	1.52 in	1.375 in	0.312 in	200.5

Note: Dimensions in mm unless otherwise noted. For all available output shaft diameters, see page 573. For dimensions of compound gear units (ex: K57R37) see page 565.

KA57..

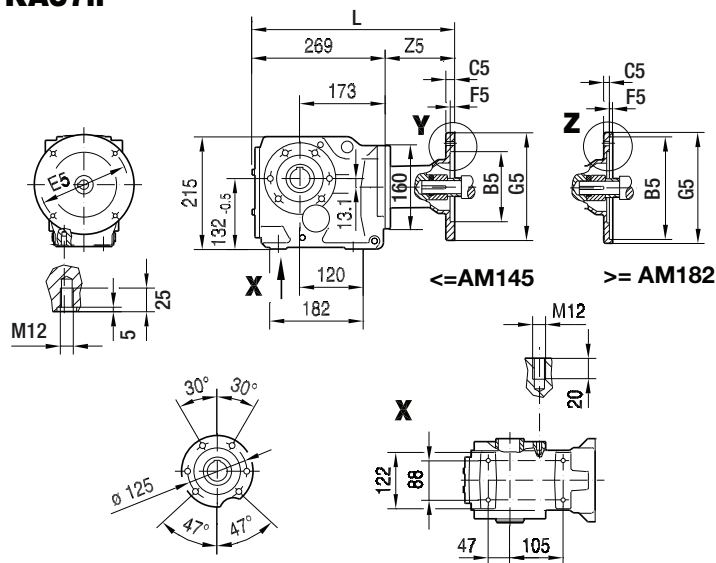

33 020 00 11

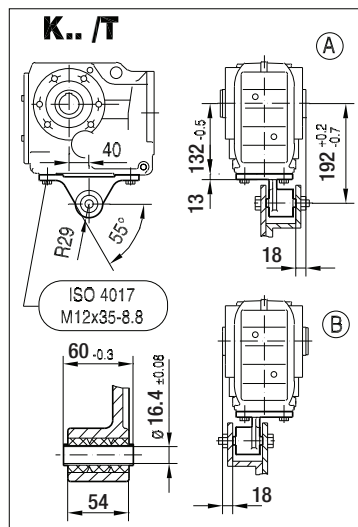

KA57..

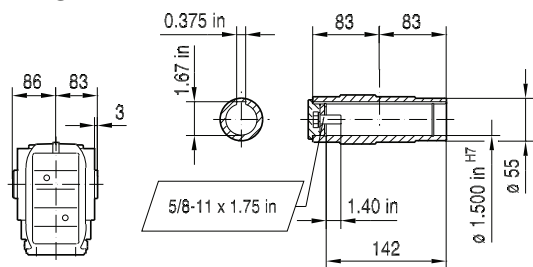

KV57..

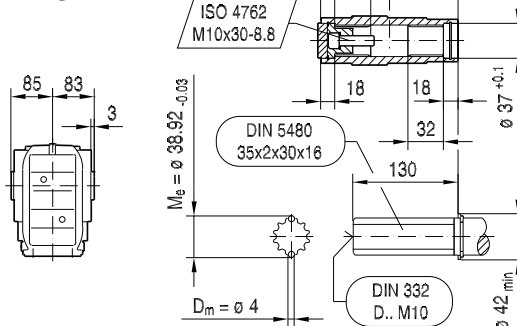

KH57..

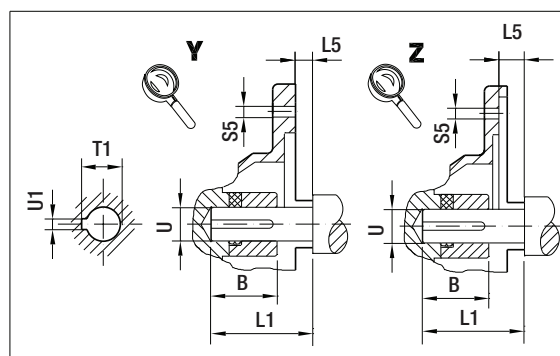
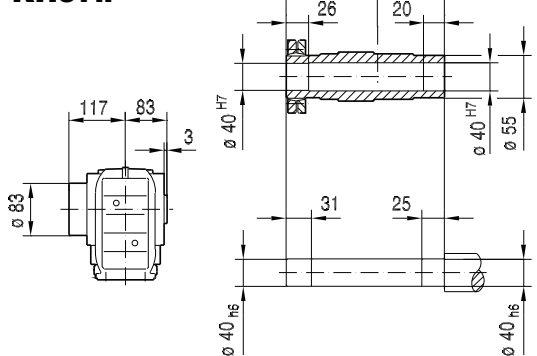

(→ 132)	B	B5	C5	F5	G5	L	L1	L5	S5	T1	U	U1	Z5
AM56	1.23 in	4.50 in	11	4.5	170	356	1.88 in	-0.18 in	10.5	0.71 in	0.625 in	0.188 in	87
AM143	1.68 in	4.50 in	12	4.5	170	380	2.25 in	0.13 in	10.5	0.98 in	0.875 in	0.188 in	110.5
AM145	1.68 in	4.50 in	12	4.5	170	380	2.25 in	0.13 in	10.5	0.98 in	0.875 in	0.188 in	110.5
AM182	2.10 in	8.50 in	10	5	228	417	2.75 in	0.13 in	15	1.24 in	1.125 in	0.250 in	147.5
AM184	2.10 in	8.50 in	10	5	228	417	2.75 in	0.13 in	15	1.24 in	1.125 in	0.250 in	147.5
AM213/215	2.76 in	8.50 in	11	5	228	470	3.38 in	0.25 in	15	1.52 in	1.375 in	0.312 in	200.5

Note: Dimensions in mm unless otherwise noted. For all available output shaft diameters, see page 575. For dimensions of compound gear units (ex: KA57R37) see page 565.

KAZ57..

33 021 00 11

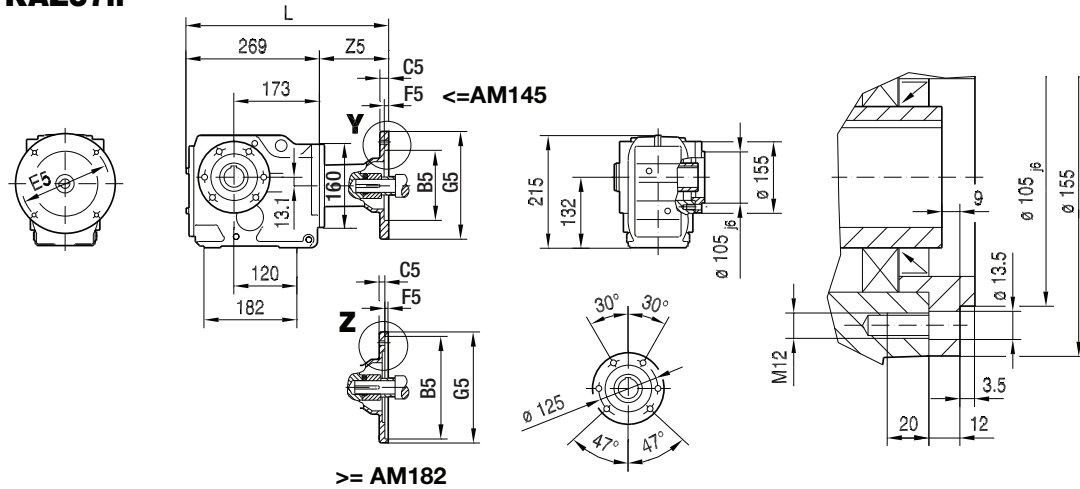

KAZ57..

KVZ57..

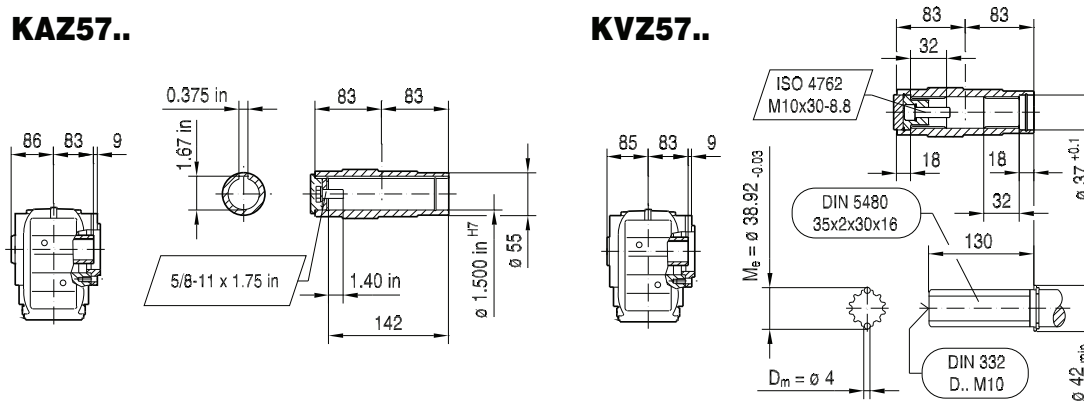

KHZ57..

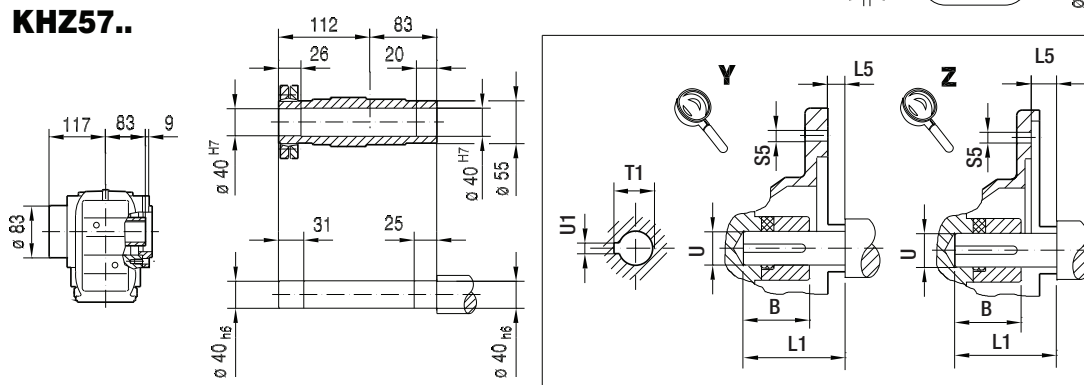

(→ 132)	B	B5	C5	E5	F5	G5	L	L1	L5	S5	T1	U	U1	Z5
AM56	1.23 in	4.50 in	11	5.875 in	4.5	170	356	1.88 in	-0.18 in	10.5	0.71 in	0.625 in	0.188 in	87
AM143	1.68 in	4.50 in	12	5.875 in	4.5	170	380	2.25 in	0.13 in	10.5	0.98 in	0.875 in	0.188 in	110.5
AM145	1.68 in	4.50 in	12	5.875 in	4.5	170	380	2.25 in	0.13 in	10.5	0.98 in	0.875 in	0.188 in	110.5
AM182	2.10 in	8.50 in	10	7.25 in	5	228	417	2.75 in	0.13 in	15	1.24 in	1.125 in	0.250 in	147.5
AM184	2.10 in	8.50 in	10	7.25 in	5	228	417	2.75 in	0.13 in	15	1.24 in	1.125 in	0.250 in	147.5
AM213/215	2.76 in	8.50 in	11	7.25 in	5	228	470	3.38 in	0.25 in	15	1.52 in	1.375 in	0.312 in	200.5

Note: Dimensions in mm unless otherwise noted. For all available output shaft diameters, see page 575. For dimensions of compound gear units (ex: KAZ57R37) see page 565.

10 K - Helical Bevel

K.. AM.. [NEMA dimensions]

KT57..

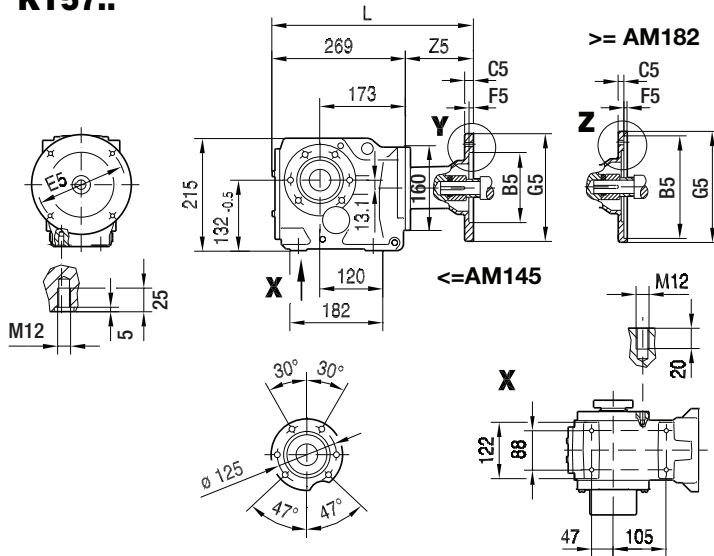

33 022 00 11

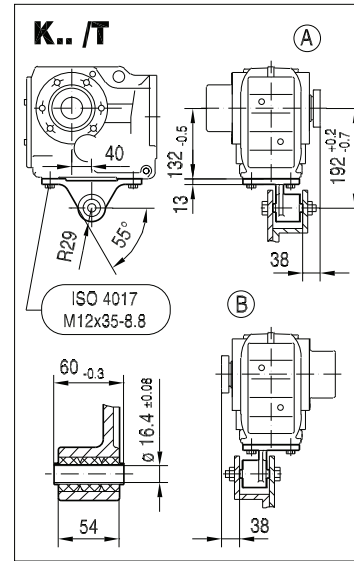

NON-Symmetrical

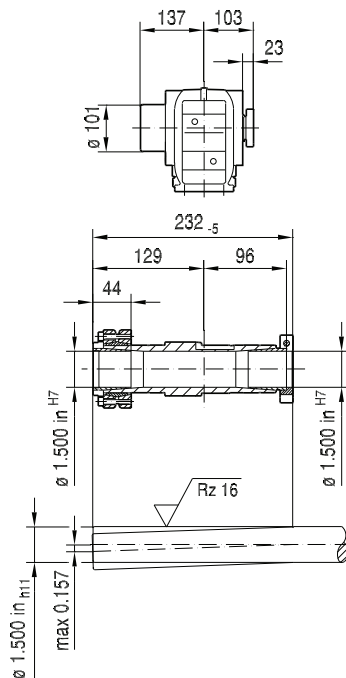

Symmetrical

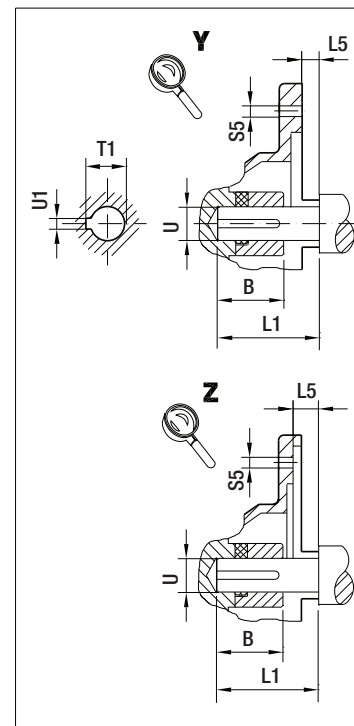
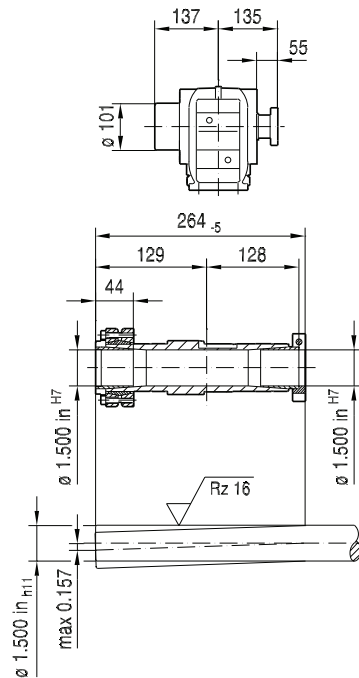

(→ 132)	B	B5	C5	E5	F5	G5	L	L1	L5	S5	T1	U	U1	Z5
AM56	1.23 in	4.50 in	11	5.875 in	4.5	170	356	1.88 in	-0.18 in	10.5	0.71 in	0.625 in	0.188 in	87
AM143	1.68 in	4.50 in	12	5.875 in	4.5	170	380	2.25 in	0.13 in	10.5	0.98 in	0.875 in	0.188 in	110.5
AM145	1.68 in	4.50 in	12	5.875 in	4.5	170	380	2.25 in	0.13 in	10.5	0.98 in	0.875 in	0.188 in	110.5
AM182	2.10 in	8.50 in	10	7.25 in	5	228	417	2.75 in	0.13 in	15	1.24 in	1.125 in	0.250 in	147.5
AM184	2.10 in	8.50 in	10	7.25 in	5	228	417	2.75 in	0.13 in	15	1.24 in	1.125 in	0.250 in	147.5
AM213/215	2.76 in	8.50 in	11	7.25 in	5	228	470	3.38 in	0.25 in	15	1.52 in	1.375 in	0.312 in	200.5

Note: Dimensions in mm unless otherwise noted. For all available output shaft diameters, see page 577. For dimensions of compound gear units (ex: KT57R37) see page 565.

33 023 00 11

K67..

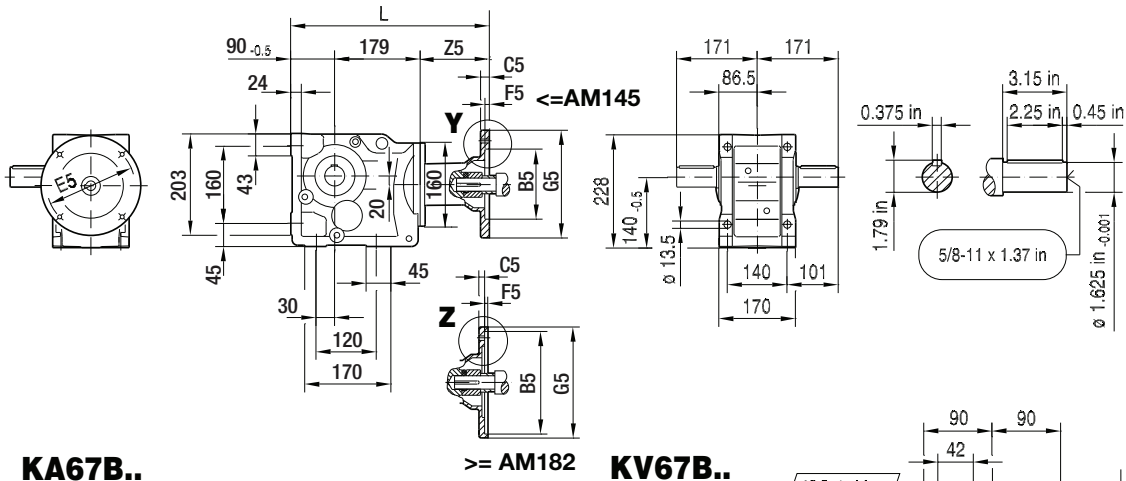

KA67B..

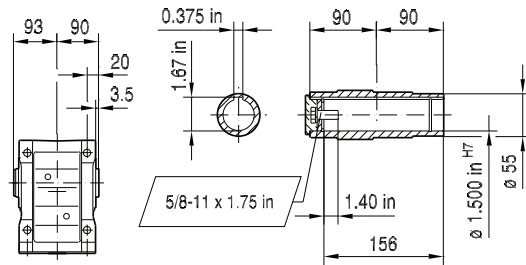

KA67B..

KV67B..

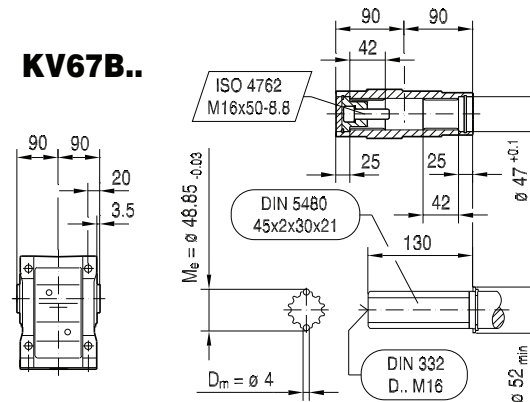

KH67B..

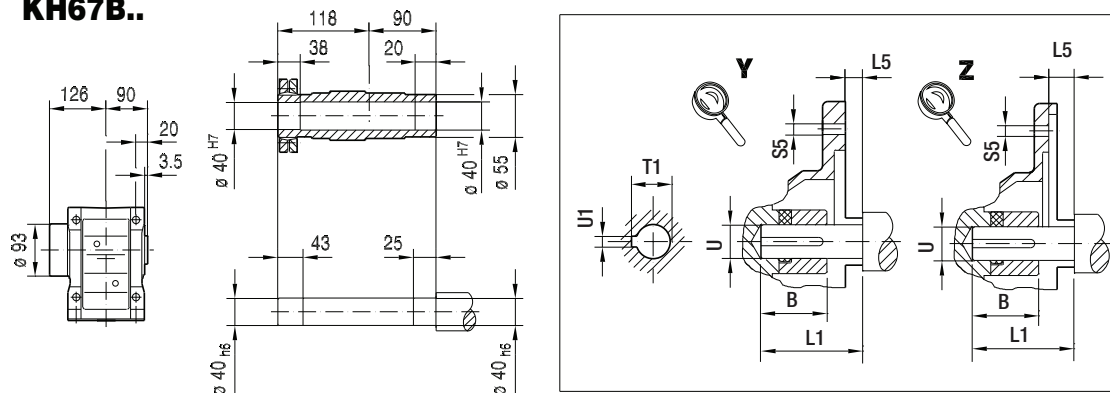

(→ 132)	B	B5	C5	E5	F5	G5	L	L1	L5	S5	T1	U	U1	Z5
AM56	1.23 in	4.50 in	11	5.875 in	4.5	170	356	1.88 in	-0.18 in	10.5	0.71 in	0.625 in	0.188 in	87
AM143	1.68 in	4.50 in	12	5.875 in	4.5	170	380	2.25 in	0.13 in	10.5	0.98 in	0.875 in	0.188 in	110.5
AM145	1.68 in	4.50 in	12	5.875 in	4.5	170	380	2.25 in	0.13 in	10.5	0.98 in	0.875 in	0.188 in	110.5
AM182	2.10 in	8.50 in	10	7.25 in	5	228	417	2.75 in	0.13 in	15	1.24 in	1.125 in	0.250 in	147.5
AM184	2.10 in	8.50 in	10	7.25 in	5	228	417	2.75 in	0.13 in	15	1.24 in	1.125 in	0.250 in	147.5
AM213/215	2.76 in	8.50 in	11	7.25 in	5	228	470	3.38 in	0.25 in	15	1.52 in	1.375 in	0.312 in	200.5

Note: Dimensions in mm unless otherwise noted. For all available output shaft diameters, see page 573. For dimensions of compound gear units (ex: K67R37) see page 565.

10 K - Helical Bevel

K.. AM.. [NEMA dimensions]

33 024 00 11

KF67..

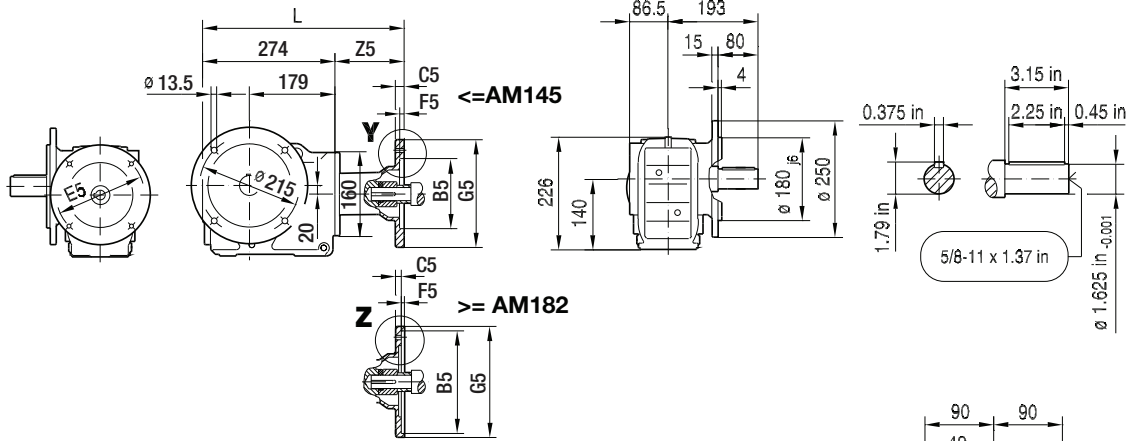

KAF67..

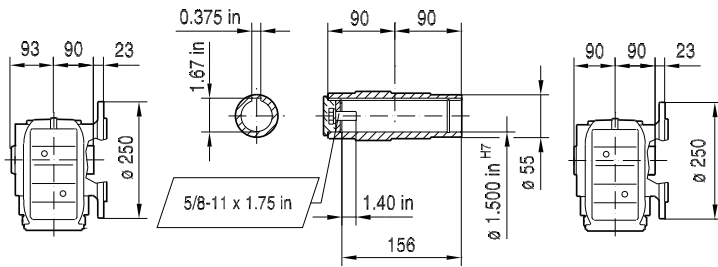

KVF67..

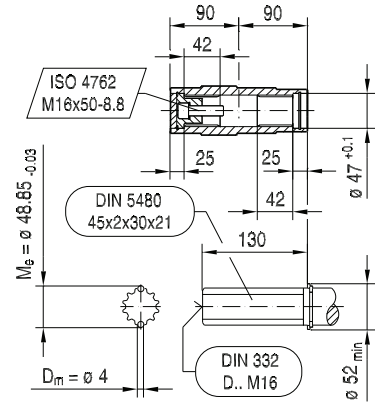

KHF67..

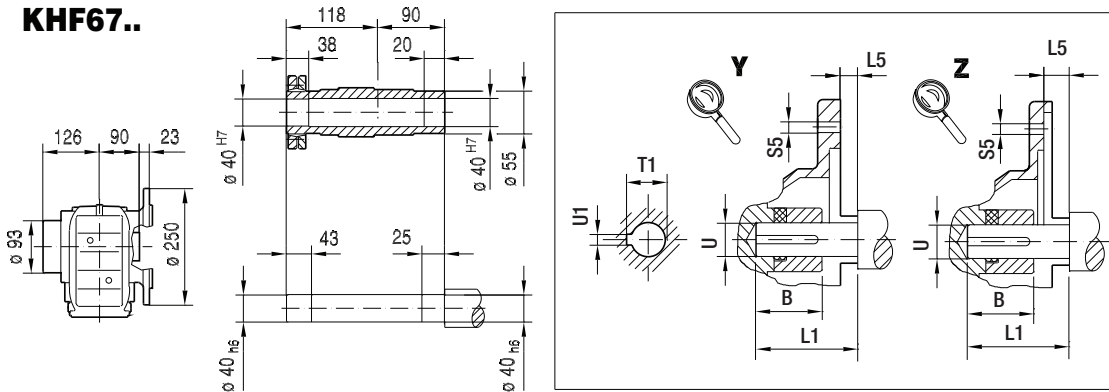

(→ 132)	B	B5	C5	E5	F5	G5	L	L1	L5	S5	T1	U	U1	Z5
AM56	1.23 in	4.50 in	11	5.875 in	4.5	170	361	1.88 in	-0.18 in	10.5	0.71 in	0.625 in	0.188 in	87
AM143	1.68 in	4.50 in	12	5.875 in	4.5	170	385	2.25 in	0.13 in	10.5	0.98 in	0.875 in	0.188 in	110.5
AM145	1.68 in	4.50 in	12	5.875 in	4.5	170	385	2.25 in	0.13 in	10.5	0.98 in	0.875 in	0.188 in	110.5
AM182	2.10 in	8.50 in	10	7.25 in	5	228	422	2.75 in	0.13 in	15	1.24 in	1.125 in	0.250 in	147.5
AM184	2.10 in	8.50 in	10	7.25 in	5	228	422	2.75 in	0.13 in	15	1.24 in	1.125 in	0.250 in	147.5
AM213/215	2.76 in	8.50 in	11	7.25 in	5	228	475	3.38 in	0.25 in	15	1.52 in	1.375 in	0.312 in	200.5

Note: Dimensions in mm unless otherwise noted. For all available output shaft diameters, see page 573. For dimensions of compound gear units (ex: KF67R37) see page 565.

KA67..

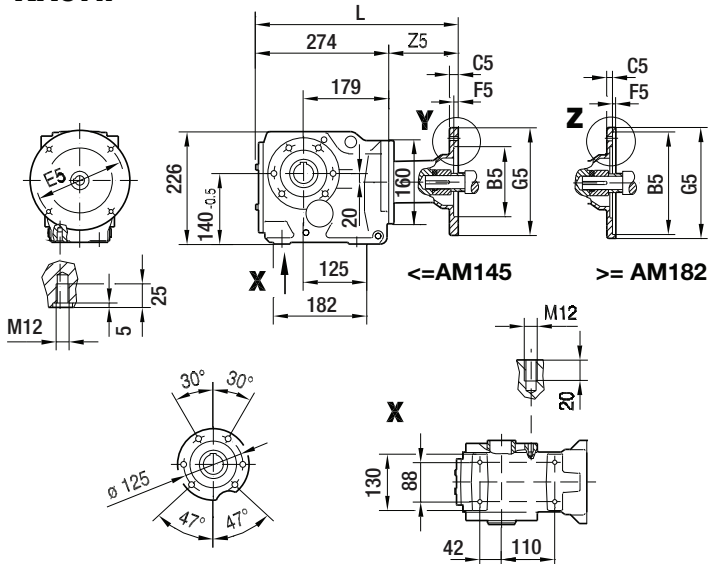

33 025 00 11

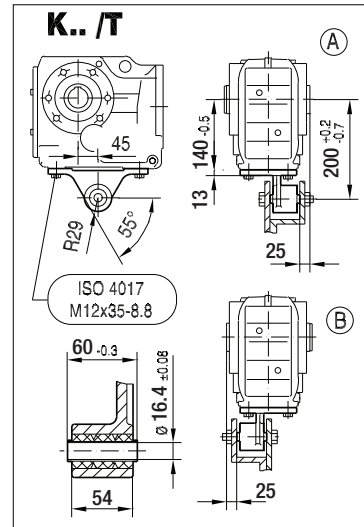

KA67..

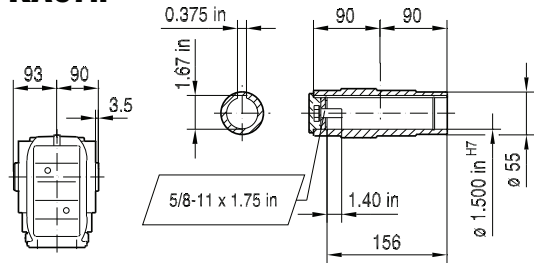

KV67..

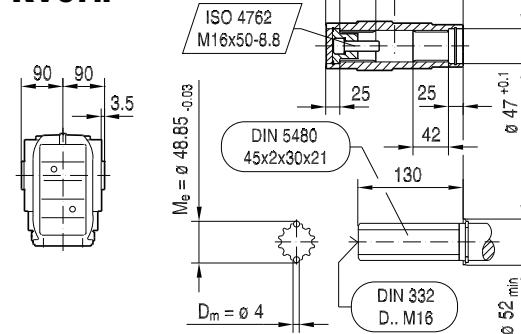

KH67..

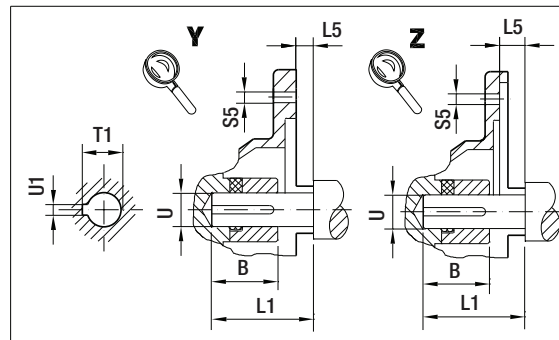
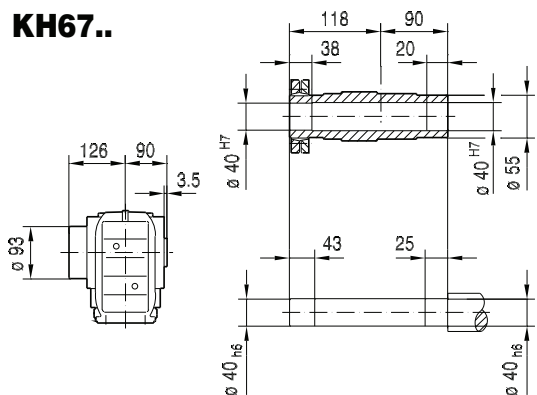

(→ 132)	B	B5	C5	E5	F5	G5	L	L1	L5	S5	T1	U	U1	Z5
AM56	1.23 in	4.50 in	11	5.875 in	4.5	170	361	1.88 in	-0.18 in	10.5	0.71 in	0.625 in	0.188 in	87
AM143	1.68 in	4.50 in	12	5.875 in	4.5	170	385	2.25 in	0.13 in	10.5	0.98 in	0.875 in	0.188 in	110.5
AM145	1.68 in	4.50 in	12	5.875 in	4.5	170	385	2.25 in	0.13 in	10.5	0.98 in	0.875 in	0.188 in	110.5
AM182	2.10 in	8.50 in	10	7.25 in	5	228	422	2.75 in	0.13 in	15	1.24 in	1.125 in	0.250 in	147.5
AM184	2.10 in	8.50 in	10	7.25 in	5	228	422	2.75 in	0.13 in	15	1.24 in	1.125 in	0.250 in	147.5
AM213/215	2.76 in	8.50 in	11	7.25 in	5	228	475	3.38 in	0.25 in	15	1.52 in	1.375 in	0.312 in	200.5

Note: Dimensions in mm unless otherwise noted. For all available output shaft diameters, see page 575. For dimensions of compound gear units (ex: KA67R37) see page 565.

10 K - Helical Bevel

K.. AM.. [NEMA dimensions]

33 026 00 11

KAZ67..

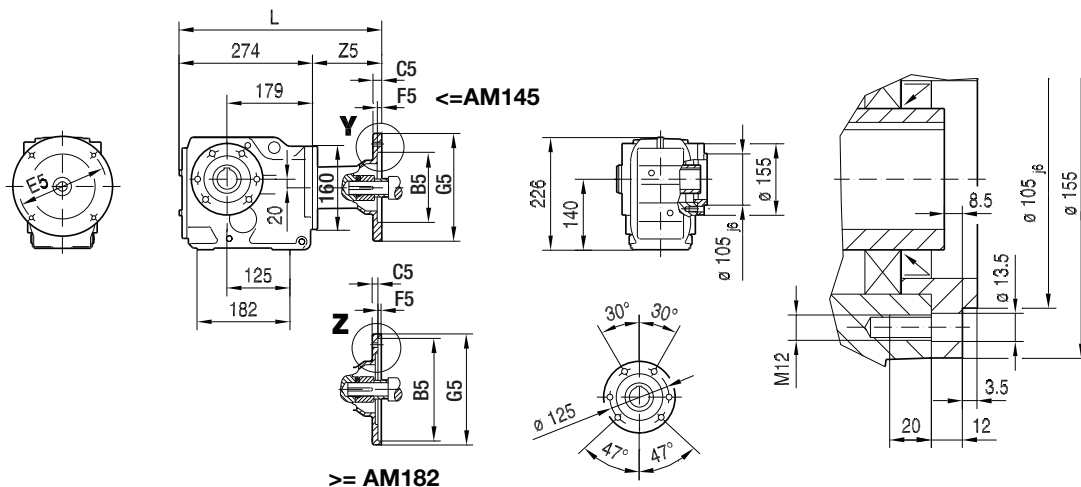

KAZ67..

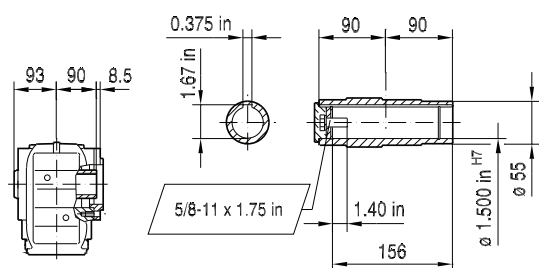

KVZ67..

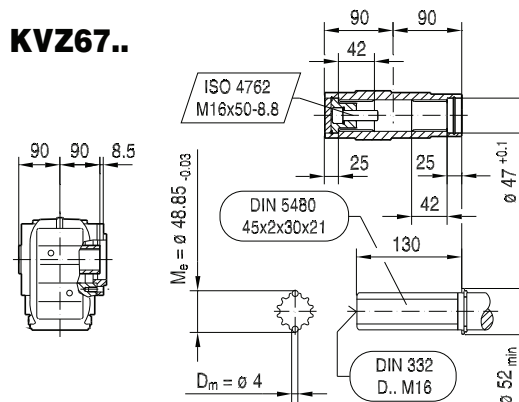

KHZ67..

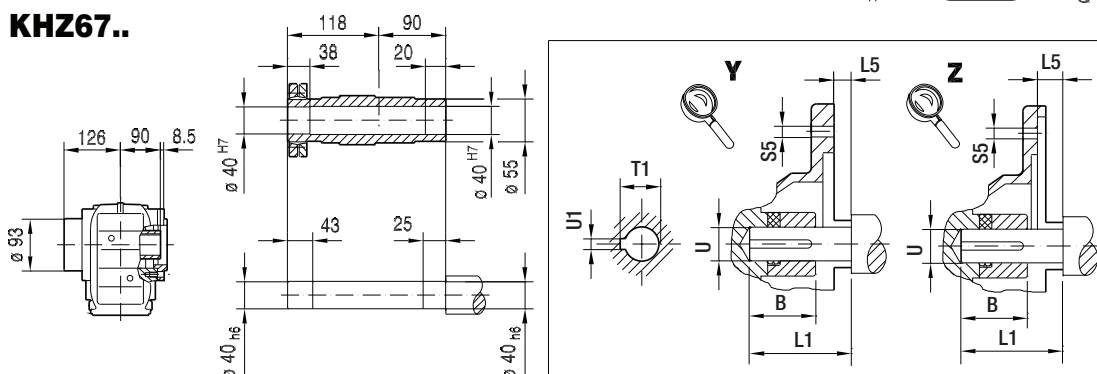

(→ 132)	B	B5	C5	E5	F5	G5	L	L1	L5	S5	T1	U	U1	Z5
AM56	1.23 in	4.50 in	11	5.875 in	4.5	170	361	1.88 in	-0.18 in	10.5	0.71 in	0.625 in	0.188 in	87
AM143	1.68 in	4.50 in	12	5.875 in	4.5	170	385	2.25 in	0.13 in	10.5	0.98 in	0.875 in	0.188 in	110.5
AM145	1.68 in	4.50 in	12	5.875 in	4.5	170	385	2.25 in	0.13 in	10.5	0.98 in	0.875 in	0.188 in	110.5
AM182	2.10 in	8.50 in	10	7.25 in	5	228	422	2.75 in	0.13 in	15	1.24 in	1.125 in	0.250 in	147.5
AM184	2.10 in	8.50 in	10	7.25 in	5	228	422	2.75 in	0.13 in	15	1.24 in	1.125 in	0.250 in	147.5
AM213/215	2.76 in	8.50 in	11	7.25 in	5	228	475	3.38 in	0.25 in	15	1.52 in	1.375 in	0.312 in	200.5

Note: Dimensions in mm unless otherwise noted. For all available output shaft diameters, see page 575. For dimensions of compound gear units (ex: KAZ67R37) see page 565.

KT67..

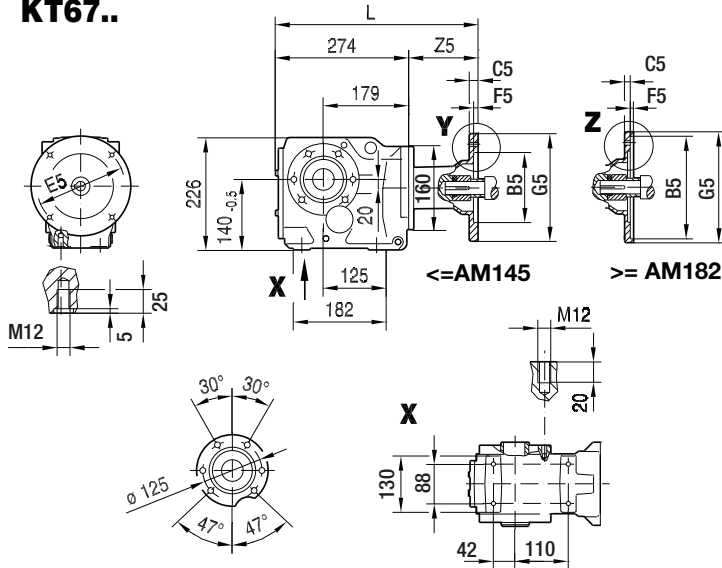

33 027 00 11

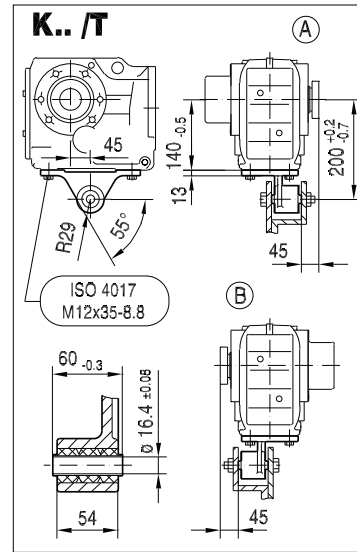

NON-Symmetrical

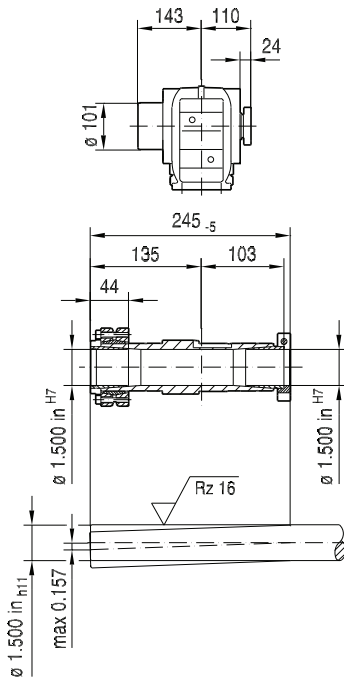

Symmetrical

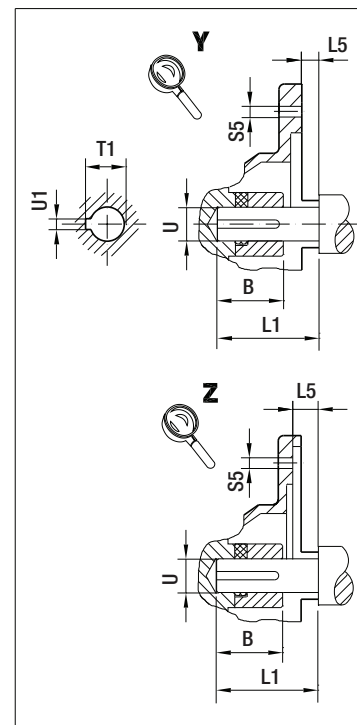
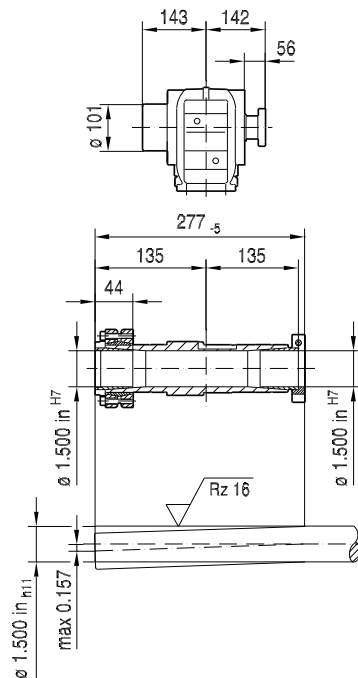

(→ 132)	B	B5	C5	E5	F5	G5	L	L1	L5	S5	T1	U	U1	Z5
AM56	1.23 in	4.50 in	11	5.875 in	4.5	170	361	1.88 in	-0.18 in	10.5	0.71 in	0.625 in	0.188 in	87
AM143	1.68 in	4.50 in	12	5.875 in	4.5	170	385	2.25 in	0.13 in	10.5	0.98 in	0.875 in	0.188 in	110.5
AM145	1.68 in	4.50 in	12	5.875 in	4.5	170	385	2.25 in	0.13 in	10.5	0.98 in	0.875 in	0.188 in	110.5
AM182	2.10 in	8.50 in	10	7.25 in	5	228	422	2.75 in	0.13 in	15	1.24 in	1.125 in	0.250 in	147.5
AM184	2.10 in	8.50 in	10	7.25 in	5	228	422	2.75 in	0.13 in	15	1.24 in	1.125 in	0.250 in	147.5
AM213/215	2.76 in	8.50 in	11	7.25 in	5	228	475	3.38 in	0.25 in	15	1.52 in	1.375 in	0.312 in	200.5

Note: Dimensions in mm unless otherwise noted. For all available output shaft diameters, see page 577. For dimensions of compound gear units (ex: KT67R37) see page 565.

10 K - Helical Bevel

K.. AM.. [NEMA dimensions]

33 028 00 11

K77..

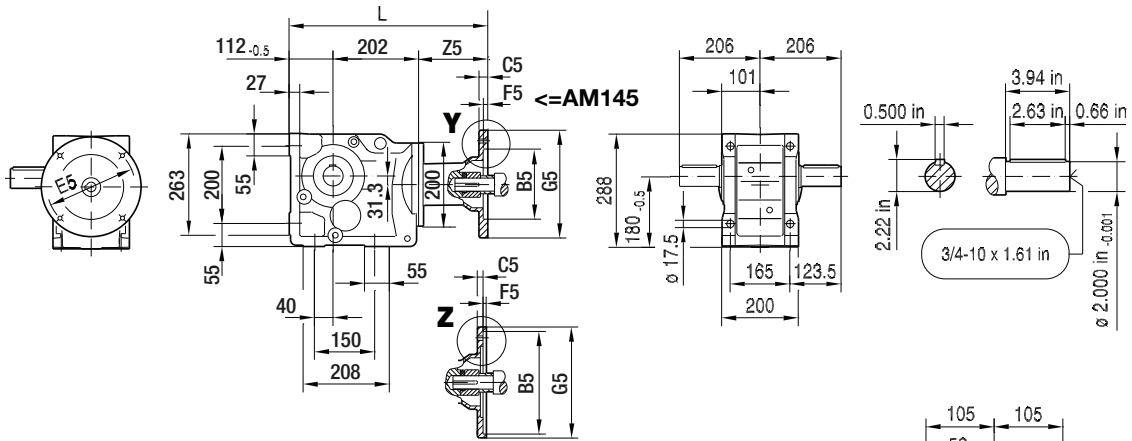

KA77B..

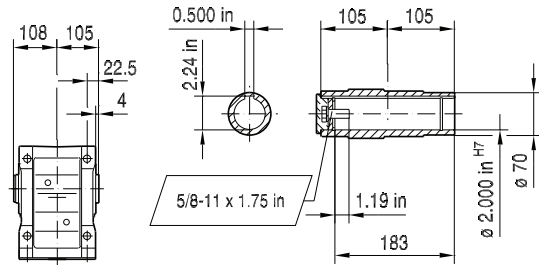

>= AM182

KV77B..

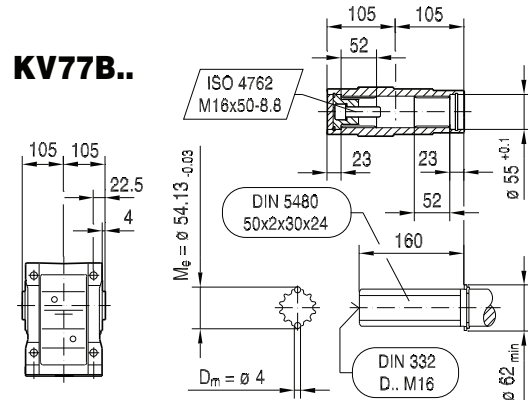

KH77B..

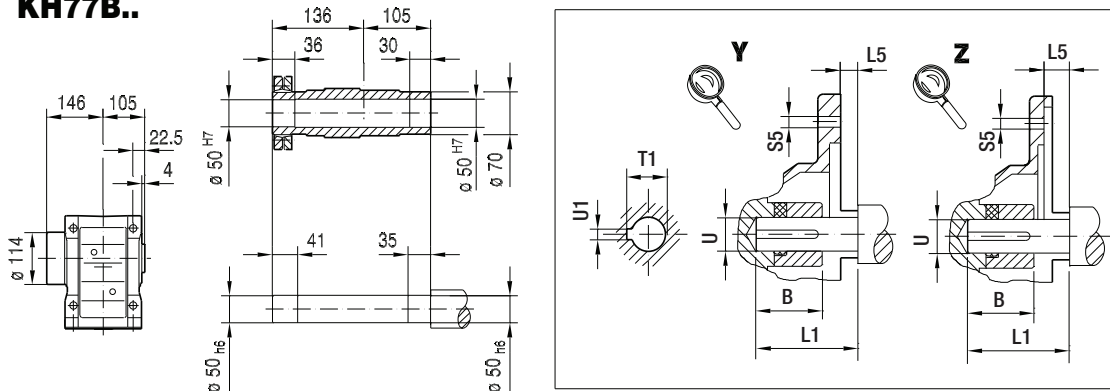

(→ 132)	B	B5	C5	E5	F5	G5	L	L1	L5	S5	T1	U	U1	Z5
AM56	1.23 in	4.50 in	11	5.875 in	4.5	170	395	1.88 in	-0.18 in	10.5	0.71 in	0.625 in	0.188 in	81
AM143	1.68 in	4.50 in	12	5.875 in	4.5	170	418	2.25 in	0.13 in	10.5	0.98 in	0.875 in	0.188 in	103.5
AM145	1.68 in	4.50 in	12	5.875 in	4.5	170	418	2.25 in	0.13 in	10.5	0.98 in	0.875 in	0.188 in	103.5
AM182	2.10 in	8.50 in	10	7.25 in	5	228	454	2.75 in	0.13 in	15	1.24 in	1.125 in	0.250 in	139.5
AM184	2.10 in	8.50 in	10	7.25 in	5	228	454	2.75 in	0.13 in	15	1.24 in	1.125 in	0.250 in	139.5
AM213/215	2.76 in	8.50 in	11	7.25 in	5	228	503	3.38 in	0.25 in	15	1.52 in	1.375 in	0.312 in	188.5

Note: Dimensions in mm unless otherwise noted. For all available output shaft diameters, see page 573. For dimensions of compound gear units (ex: K77R37) see page 565.

33 029 00 11

KF77..

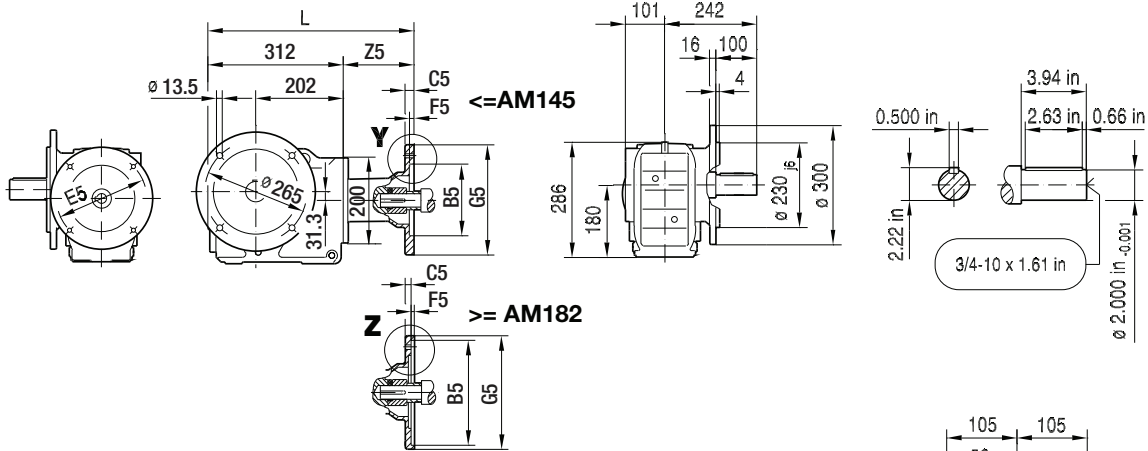

KAF77..

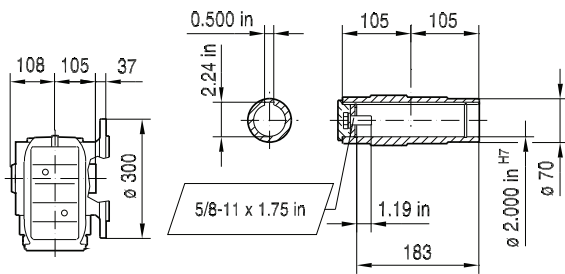

KVF77..

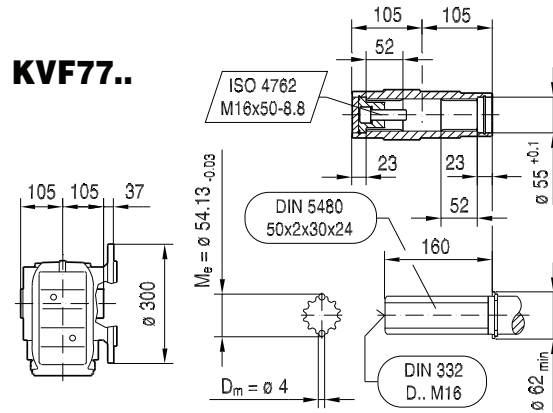

KHF77..

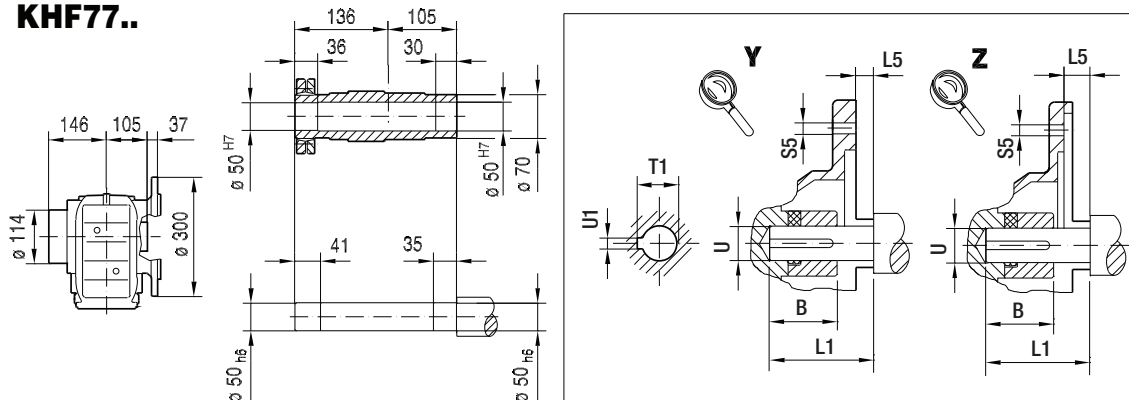

(→ 132)	B	B5	C5	E5	F5	G5	L	L1	L5	S5	T1	U	U1	Z5
AM56	1.23 in	4.50 in	11	5.875 in	4.5	170	393	1.88 in	-0.18 in	10.5	0.71 in	0.625 in	0.188 in	81
AM143	1.68 in	4.50 in	12	5.875 in	4.5	170	416	2.25 in	0.13 in	10.5	0.98 in	0.875 in	0.188 in	103.5
AM145	1.68 in	4.50 in	12	5.875 in	4.5	170	416	2.25 in	0.13 in	10.5	0.98 in	0.875 in	0.188 in	103.5
AM182	2.10 in	8.50 in	10	7.25 in	5	228	452	2.75 in	0.13 in	15	1.24 in	1.125 in	0.250 in	139.5
AM184	2.10 in	8.50 in	10	7.25 in	5	228	452	2.75 in	0.13 in	15	1.24 in	1.125 in	0.250 in	139.5
AM213/215	2.76 in	8.50 in	11	7.25 in	5	228	501	3.38 in	0.25 in	15	1.52 in	1.375 in	0.312 in	188.5

Note: Dimensions in mm unless otherwise noted. For all available output shaft diameters, see page 573. For dimensions of compound gear units (ex: KF77R37) see page 565.

10 K - Helical Bevel

K.. AM.. [NEMA dimensions]

KA77..

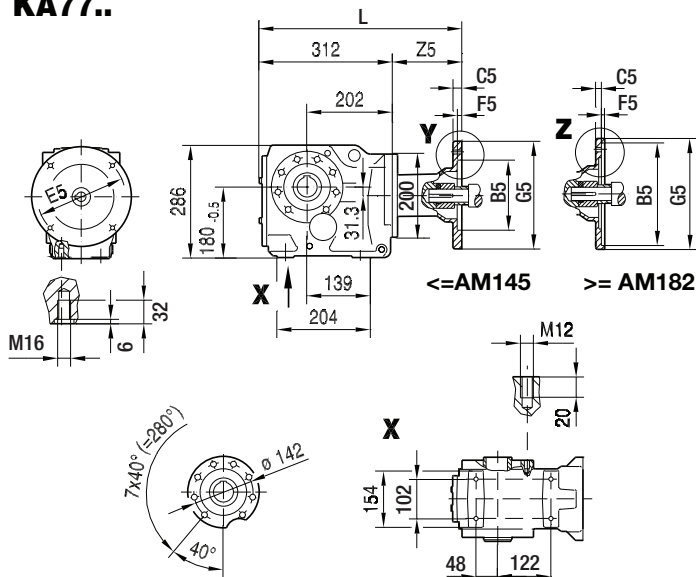

33 030 00 11

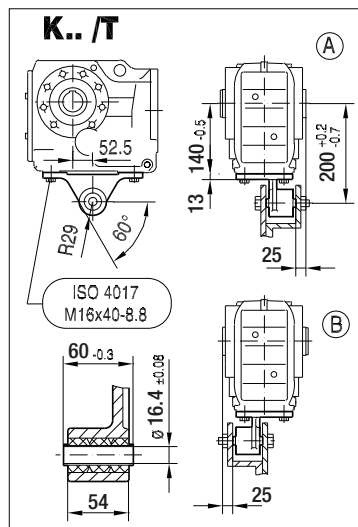

KA77..

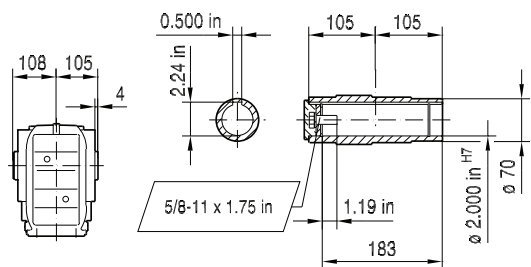

KV77..

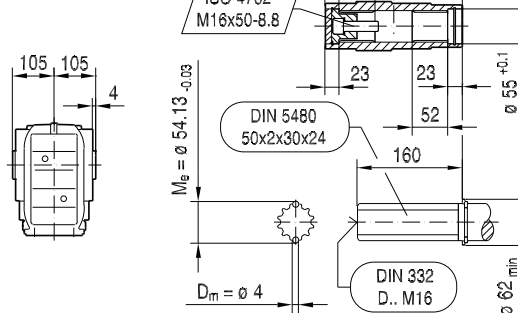

KH77..

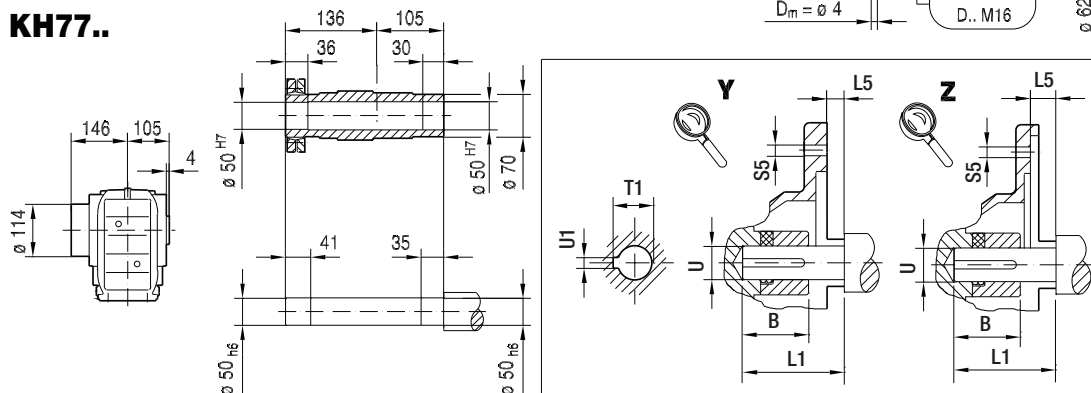

(→ 132)	B	B5	C5	E5	F5	G5	L	L1	L5	S5	T1	U	U1	Z5
AM56	1.23 in	4.50 in	11	5.875 in	4.5	170	393	1.88 in	-0.18 in	10.5	0.71 in	0.625 in	0.188 in	81
AM143	1.68 in	4.50 in	12	5.875 in	4.5	170	416	2.25 in	0.13 in	10.5	0.98 in	0.875 in	0.188 in	103.5
AM145	1.68 in	4.50 in	12	5.875 in	4.5	170	416	2.25 in	0.13 in	10.5	0.98 in	0.875 in	0.188 in	103.5
AM182	2.10 in	8.50 in	10	7.25 in	5	228	452	2.75 in	0.13 in	15	1.24 in	1.125 in	0.250 in	139.5
AM184	2.10 in	8.50 in	10	7.25 in	5	228	452	2.75 in	0.13 in	15	1.24 in	1.125 in	0.250 in	139.5
AM213/215	2.76 in	8.50 in	11	7.25 in	5	228	501	3.38 in	0.25 in	15	1.52 in	1.375 in	0.312 in	188.5

Note: Dimensions in mm unless otherwise noted. For all available output shaft diameters, see page 575. For dimensions of compound gear units (ex: KA77R37) see page 565.

33 031 00 11

KAZ77..

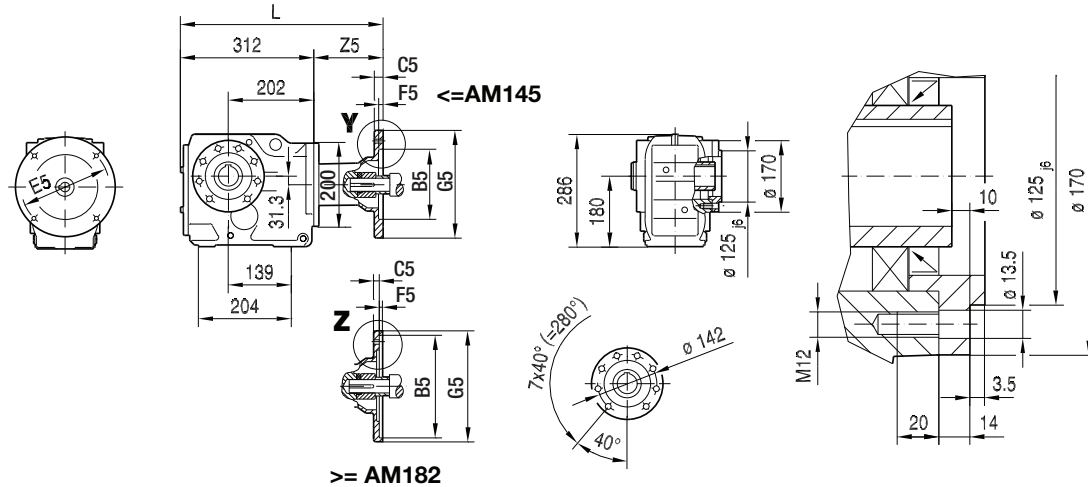

KAZ77..

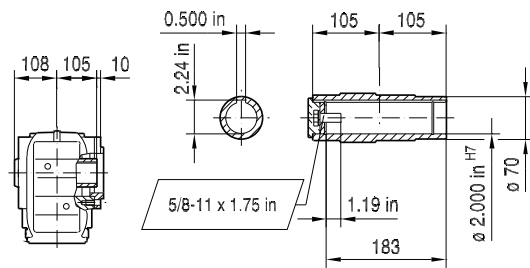

KVZ77..

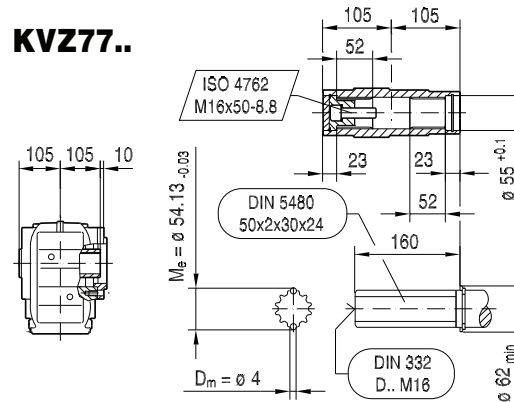

KHZ77..

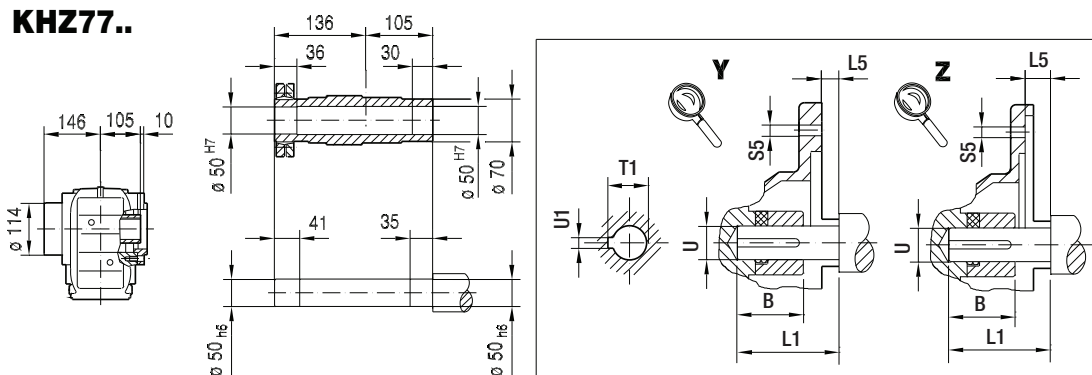

(→ 132)	B	B5	C5	E5	F5	G5	L	L1	L5	S5	T1	U	U1	Z5
AM56	1.23 in	4.50 in	11	5.875 in	4.5	170	393	1.88 in	-0.18 in	10.5	0.71 in	0.625 in	0.188 in	81
AM143	1.68 in	4.50 in	12	5.875 in	4.5	170	416	2.25 in	0.13 in	10.5	0.98 in	0.875 in	0.188 in	103.5
AM145	1.68 in	4.50 in	12	5.875 in	4.5	170	416	2.25 in	0.13 in	10.5	0.98 in	0.875 in	0.188 in	103.5
AM182	2.10 in	8.50 in	10	7.25 in	5	228	452	2.75 in	0.13 in	15	1.24 in	1.125 in	0.250 in	139.5
AM184	2.10 in	8.50 in	10	7.25 in	5	228	452	2.75 in	0.13 in	15	1.24 in	1.125 in	0.250 in	139.5
AM213/215	2.76 in	8.50 in	11	7.25 in	5	228	501	3.38 in	0.25 in	15	1.52 in	1.375 in	0.312 in	188.5

Note: Dimensions in mm unless otherwise noted. For all available output shaft diameters, see page 575. For dimensions of compound gear units (ex: KAZ77R37) see page 565.

10 K - Helical Bevel

K.. AM.. [NEMA dimensions]

KT77..

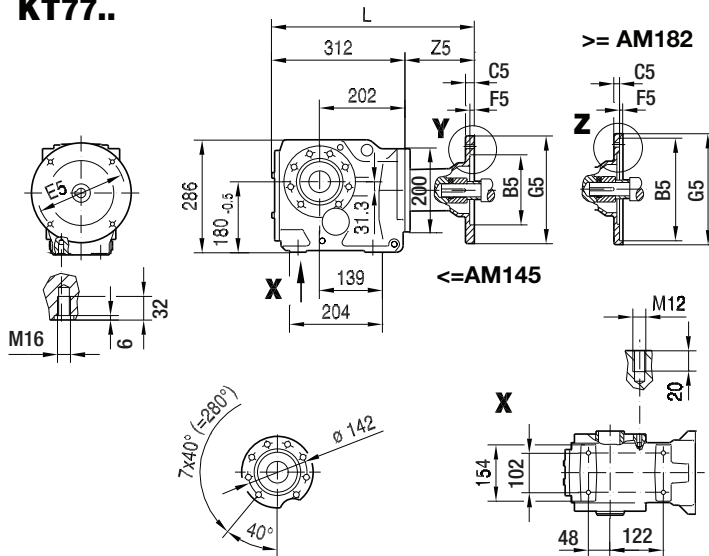

33 032 00 11

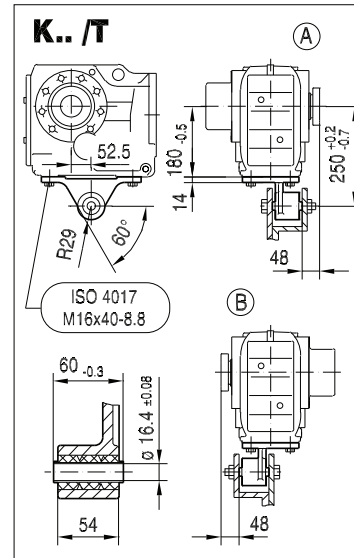

NON-Symmetrical

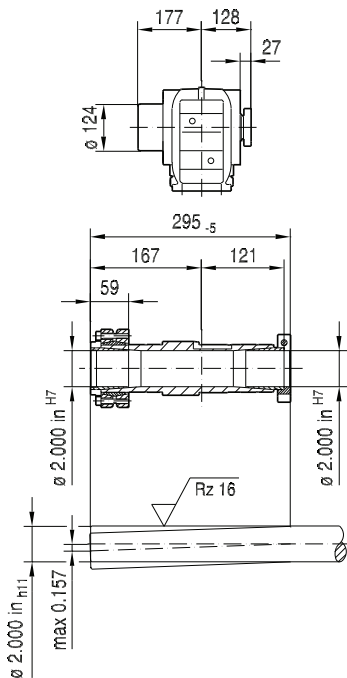

Symmetrical

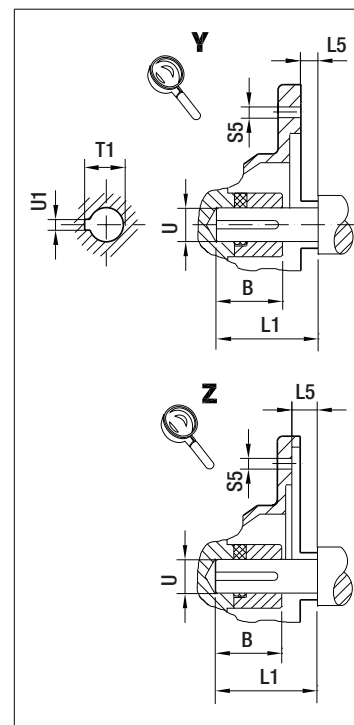
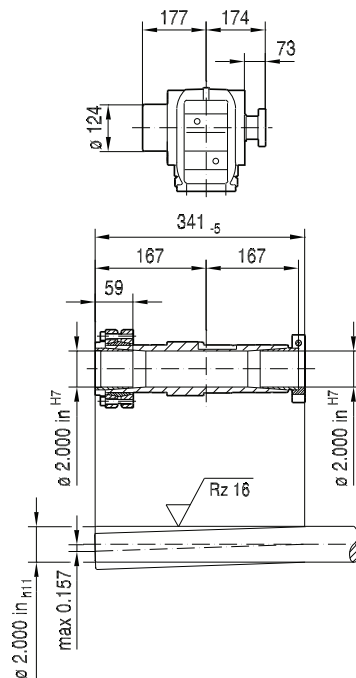

(→ 132)	B	B5	C5	E5	F5	G5	L	L1	L5	S5	T1	U	U1	Z5
AM56	1.23 in	4.50 in	11	5.875 in	4.5	170	393	1.88 in	-0.18 in	10.5	0.71 in	0.625 in	0.188 in	81
AM143	1.68 in	4.50 in	12	5.875 in	4.5	170	416	2.25 in	0.13 in	10.5	0.98 in	0.875 in	0.188 in	103.5
AM145	1.68 in	4.50 in	12	5.875 in	4.5	170	416	2.25 in	0.13 in	10.5	0.98 in	0.875 in	0.188 in	103.5
AM182	2.10 in	8.50 in	10	7.25 in	5	228	452	2.75 in	0.13 in	15	1.24 in	1.125 in	0.250 in	139.5
AM184	2.10 in	8.50 in	10	7.25 in	5	228	452	2.75 in	0.13 in	15	1.24 in	1.125 in	0.250 in	139.5
AM213/215	2.76 in	8.50 in	11	7.25 in	5	228	501	3.38 in	0.25 in	15	1.52 in	1.375 in	0.312 in	188.5

Note: Dimensions in mm unless otherwise noted. For all available output shaft diameters, see page 577. For dimensions of compound gear units (ex: KT77R37) see page 565.

K87..

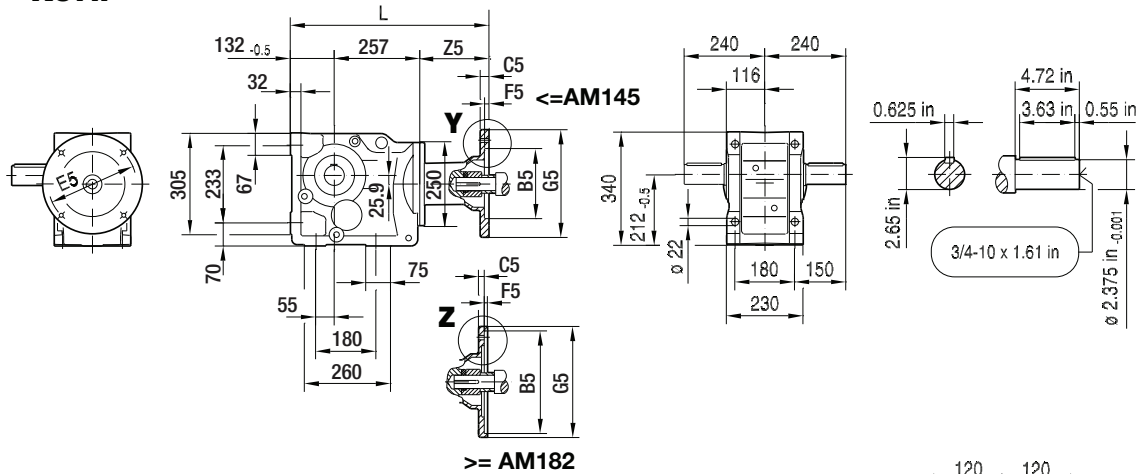

33 033 00 11

KA87B..

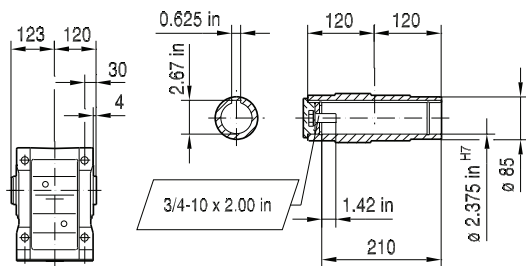

KV87B..

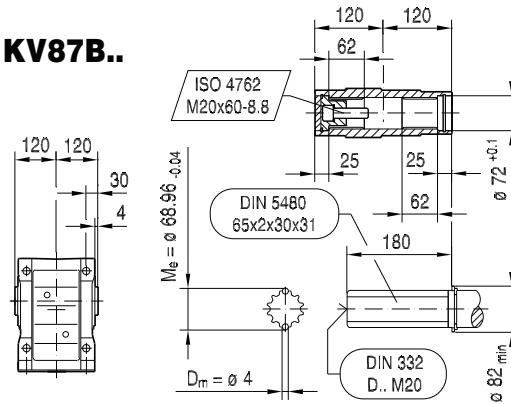

KH87B..

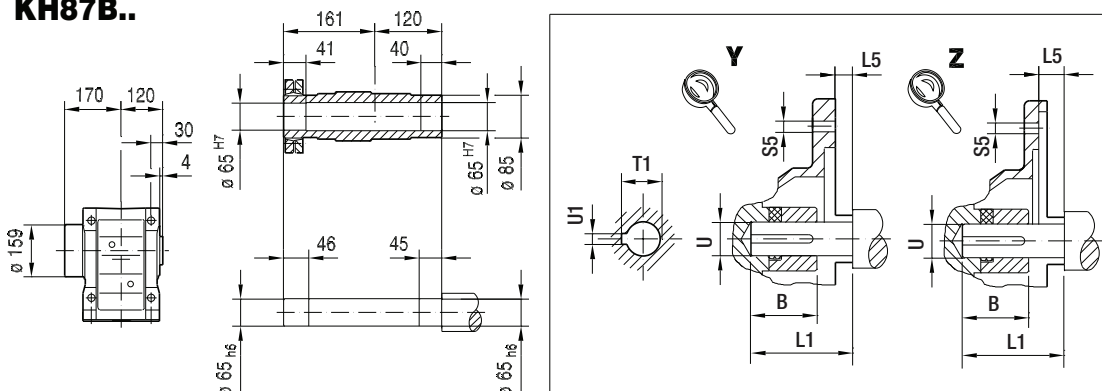

(→ 132)	B	B5	C5	E5	F5	G5	L	L1	L5	S5	T1	U	U1	Z5
AM143	1.68 in	4.50 in	12	5.875 in	4.5	170	488	2.25 in	0.13 in	10.5	0.98 in	0.875 in	0.188 in	98.5
AM145	1.68 in	4.50 in	12	5.875 in	4.5	170	488	2.25 in	0.13 in	10.5	0.98 in	0.875 in	0.188 in	98.5
AM182	2.10 in	8.50 in	10	7.25 in	5	228	524	2.75 in	0.13 in	15	1.24 in	1.125 in	0.250 in	134.5
AM184	2.10 in	8.50 in	10	7.25 in	5	228	524	2.75 in	0.13 in	15	1.24 in	1.125 in	0.250 in	134.5
AM213/215	2.76 in	8.50 in	11	7.25 in	5	228	573	3.38 in	0.25 in	15	1.52 in	1.375 in	0.312 in	183.5
AM254/256	3.65 in	8.50 in	14	7.25 in	5	228	623	4.00 in	0.25 in	15	1.80 in	1.625 in	0.375 in	234
AM284/286	4.00 in	10.50 in	15	9.00 in	5	286	630	4.62 in	0.25 in	15	2.10 in	1.875 in	0.500 in	241

Note: Dimensions in mm unless otherwise noted. For all available output shaft diameters, see page 573. For dimensions of compound gear units (ex: K87R57) see page 565.

10 K - Helical Bevel

K.. AM.. [NEMA dimensions]

33 034 00 11

KF87..

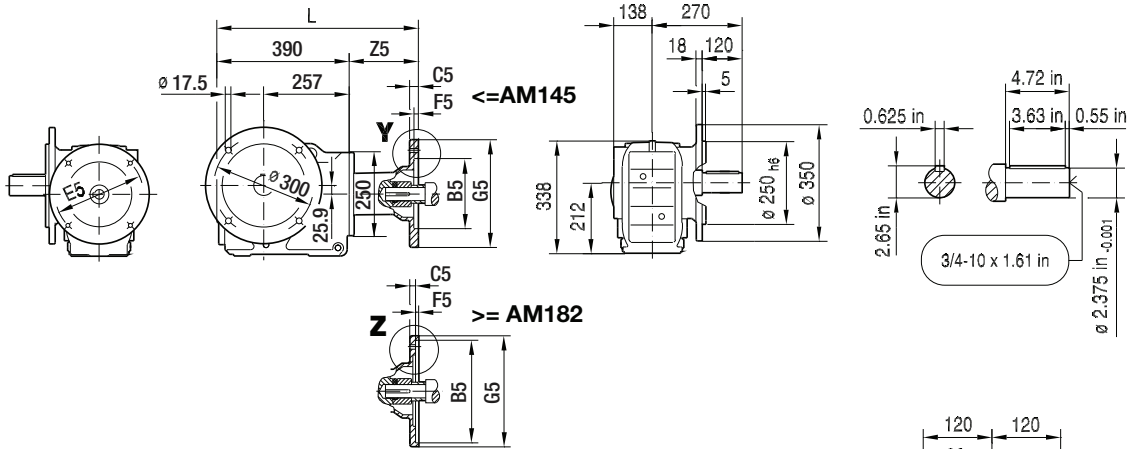

KAF87..

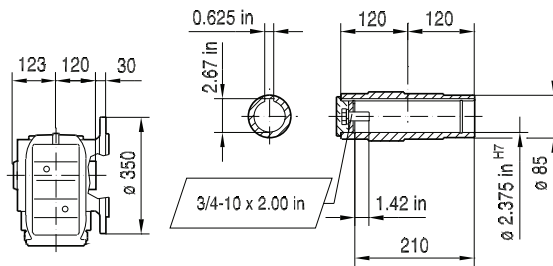

KVF87..

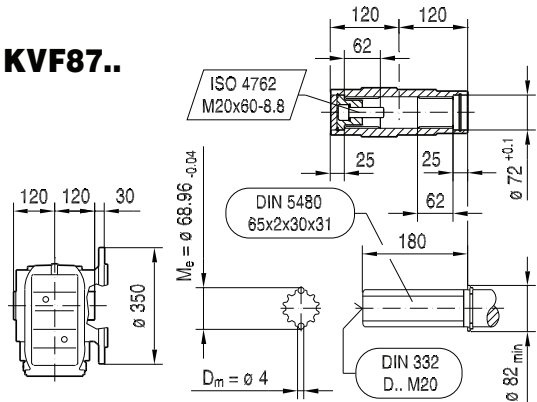

KHF87..

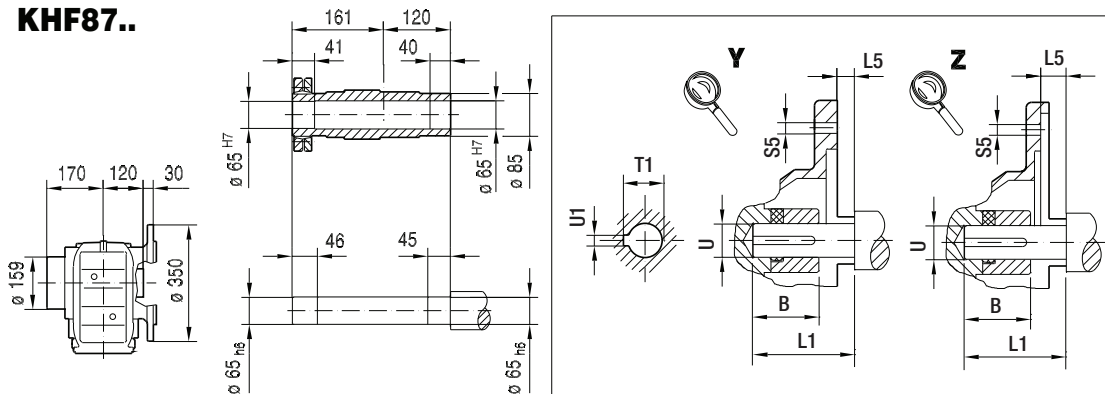

(→ 132)	B	B5	C5	E5	F5	G5	L	L1	L5	S5	T1	U	U1	Z5
AM143	1.68 in	4.50 in	12	5.875 in	4.5	170	489	2.25 in	0.13 in	10.5	0.98 in	0.875 in	0.188 in	98.5
AM145	1.68 in	4.50 in	12	5.875 in	4.5	170	489	2.25 in	0.13 in	10.5	0.98 in	0.875 in	0.188 in	98.5
AM182	2.10 in	8.50 in	10	7.25 in	5	228	525	2.75 in	0.13 in	15	1.24 in	1.125 in	0.250 in	134.5
AM184	2.10 in	8.50 in	10	7.25 in	5	228	525	2.75 in	0.13 in	15	1.24 in	1.125 in	0.250 in	134.5
AM213/215	2.76 in	8.50 in	11	7.25 in	5	228	574	3.38 in	0.25 in	15	1.52 in	1.375 in	0.312 in	183.5
AM254/256	3.65 in	8.50 in	14	7.25 in	5	228	624	4.00 in	0.25 in	15	1.80 in	1.625 in	0.375 in	234
AM284/286	4.00 in	10.50 in	15	9.00 in	5	286	631	4.62 in	0.25 in	15	2.10 in	1.875 in	0.500 in	241

Note: Dimensions in mm unless otherwise noted. For all available output shaft diameters, see page 573. For dimensions of compound gear units (ex: KF87R57) see page 565.

KA87..

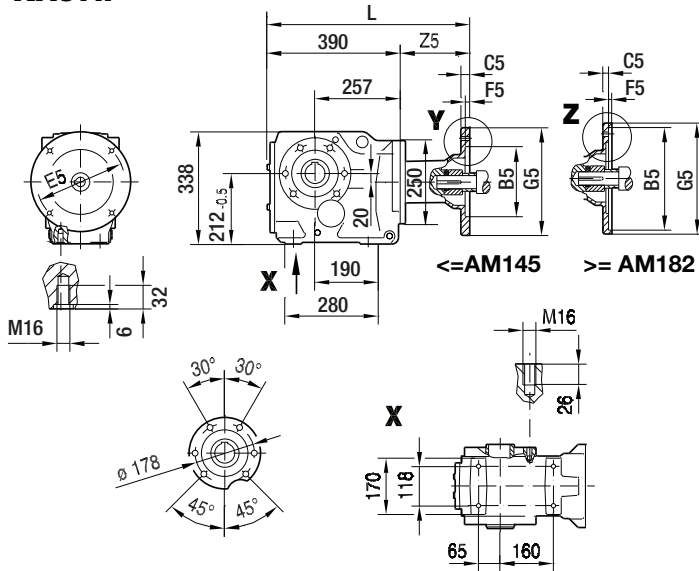

33 035 00 11

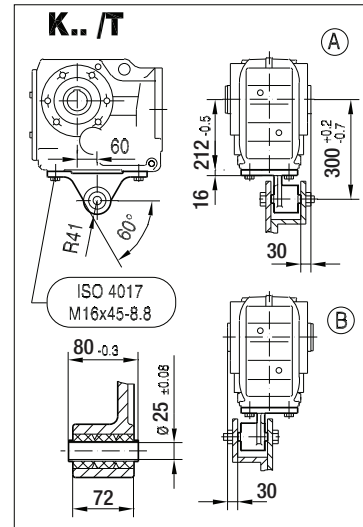

KA87..

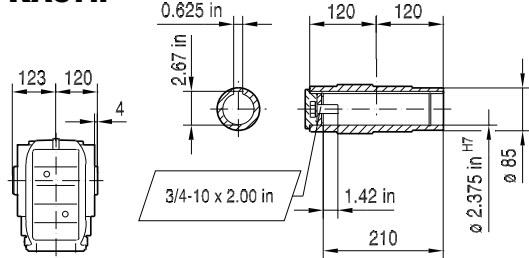

KV87..

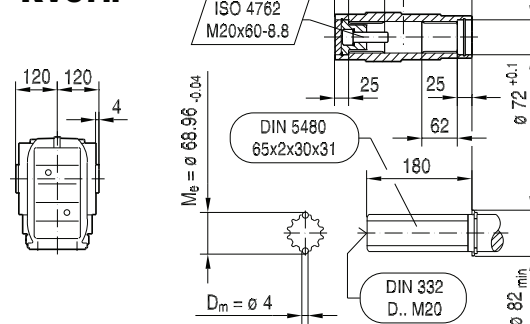

KH87..

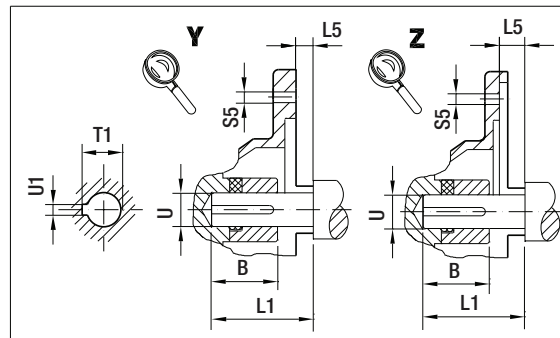
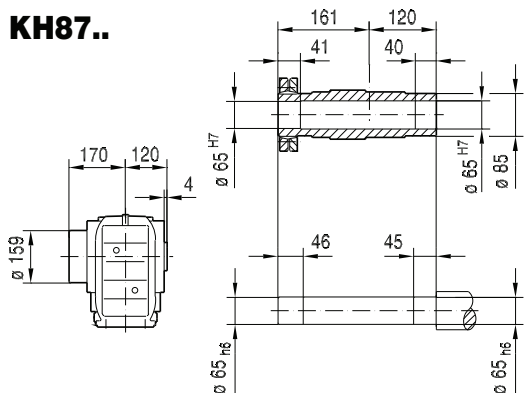

(→ 132)	B	B5	C5	E5	F5	G5	L	L1	L5	S5	T1	U	U1	Z5
AM143	1.68 in	4.50 in	12	5.875 in	4.5	170	489	2.25 in	0.13 in	10.5	0.98 in	0.875 in	0.188 in	98.5
AM145	1.68 in	4.50 in	12	5.875 in	4.5	170	489	2.25 in	0.13 in	10.5	0.98 in	0.875 in	0.188 in	98.5
AM182	2.10 in	8.50 in	10	7.25 in	5	228	525	2.75 in	0.13 in	15	1.24 in	1.125 in	0.250 in	134.5
AM184	2.10 in	8.50 in	10	7.25 in	5	228	525	2.75 in	0.13 in	15	1.24 in	1.125 in	0.250 in	134.5
AM213/215	2.76 in	8.50 in	11	7.25 in	5	228	574	3.38 in	0.25 in	15	1.52 in	1.375 in	0.312 in	183.5
AM254/256	3.65 in	8.50 in	14	7.25 in	5	228	624	4.00 in	0.25 in	15	1.80 in	1.625 in	0.375 in	234
AM284/286	4.00 in	10.50 in	15	9.00 in	5	286	631	4.62 in	0.25 in	15	2.10 in	1.875 in	0.500 in	241

Note: Dimensions in mm unless otherwise noted. For all available output shaft diameters, see page 575. For dimensions of compound gear units (ex: KA87R57) see page 565.

10 K - Helical Bevel

K.. AM.. [NEMA dimensions]

33 036 00 11

KAZ87..

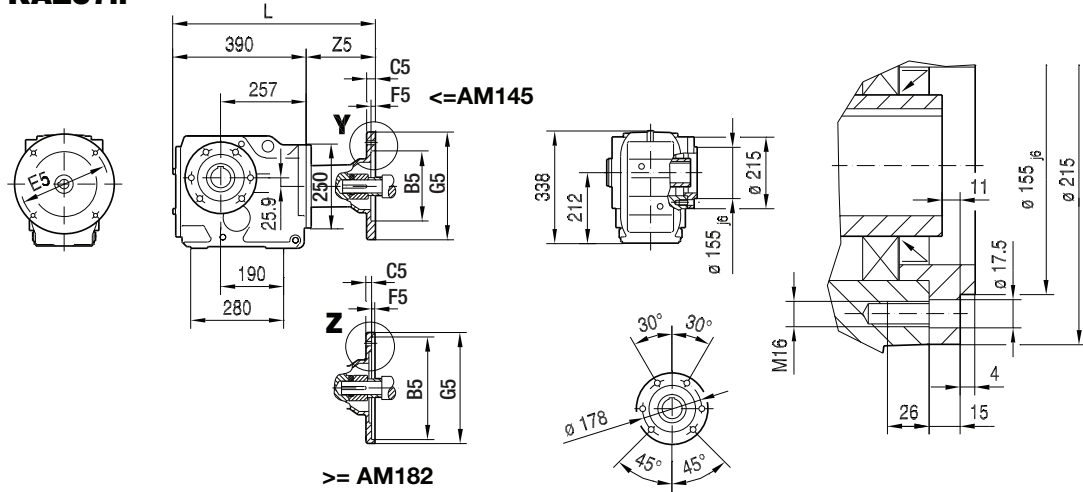

KAZ87..

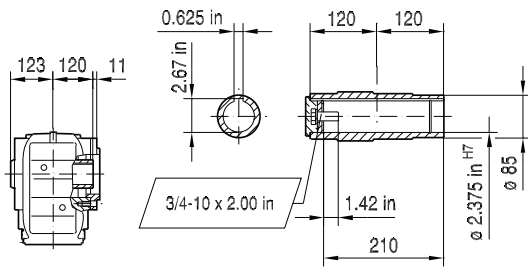

KVZ87..

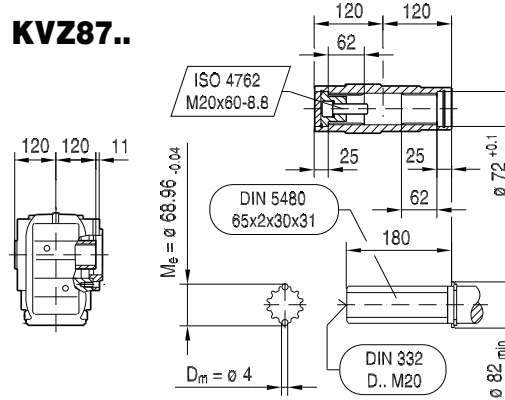

KHZ87..

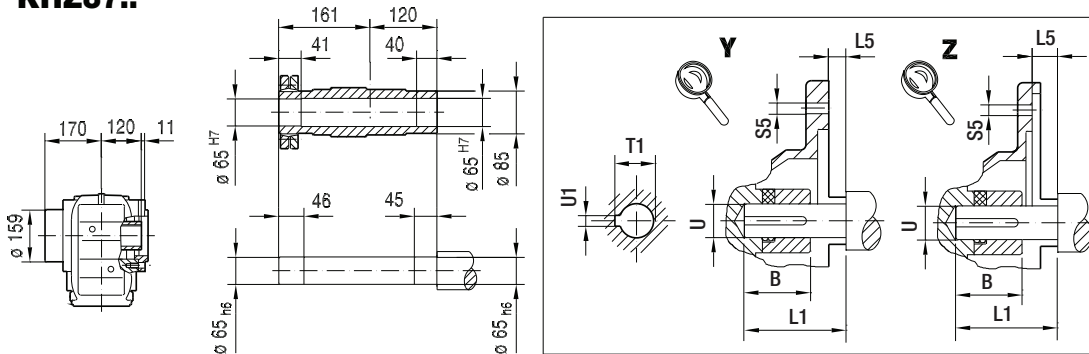

(→ 132)	B	B5	C5	E5	F5	G5	L	L1	L5	S5	T1	U	U1	Z5
AM143	1.68 in	4.50 in	12	5.875 in	4.5	170	489	2.25 in	0.13 in	10.5	0.98 in	0.875 in	0.188 in	98.5
AM145	1.68 in	4.50 in	12	5.875 in	4.5	170	489	2.25 in	0.13 in	10.5	0.98 in	0.875 in	0.188 in	98.5
AM182	2.10 in	8.50 in	10	7.25 in	5	228	525	2.75 in	0.13 in	15	1.24 in	1.125 in	0.250 in	134.5
AM184	2.10 in	8.50 in	10	7.25 in	5	228	525	2.75 in	0.13 in	15	1.24 in	1.125 in	0.250 in	134.5
AM213/215	2.76 in	8.50 in	11	7.25 in	5	228	574	3.38 in	0.25 in	15	1.52 in	1.375 in	0.312 in	183.5
AM254/256	3.65 in	8.50 in	14	7.25 in	5	228	624	4.00 in	0.25 in	15	1.80 in	1.625 in	0.375 in	234
AM284/286	4.00 in	10.50 in	15	9.00 in	5	286	631	4.62 in	0.25 in	15	2.10 in	1.875 in	0.500 in	241

Note: Dimensions in mm unless otherwise noted. For all available output shaft diameters, see page 575. For dimensions of compound gear units (ex: KAZ87R57) see page 565.

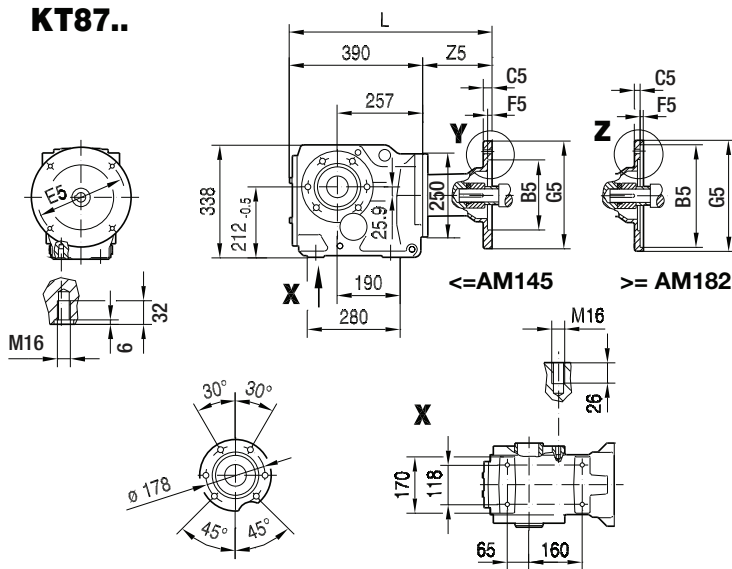

33 037 00 11

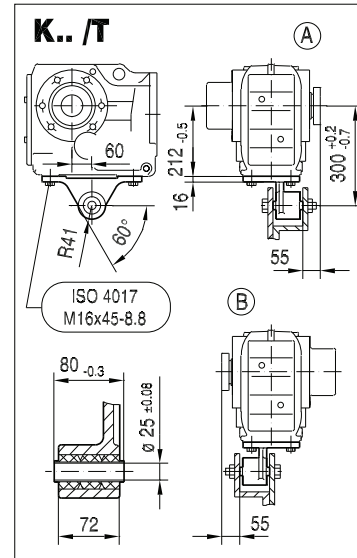

NON-Symmetrical

Symmetrical

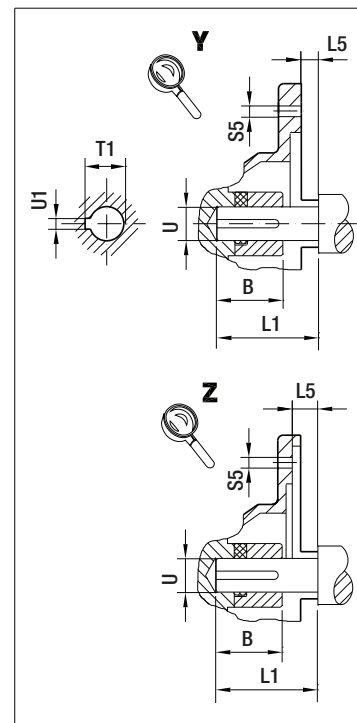
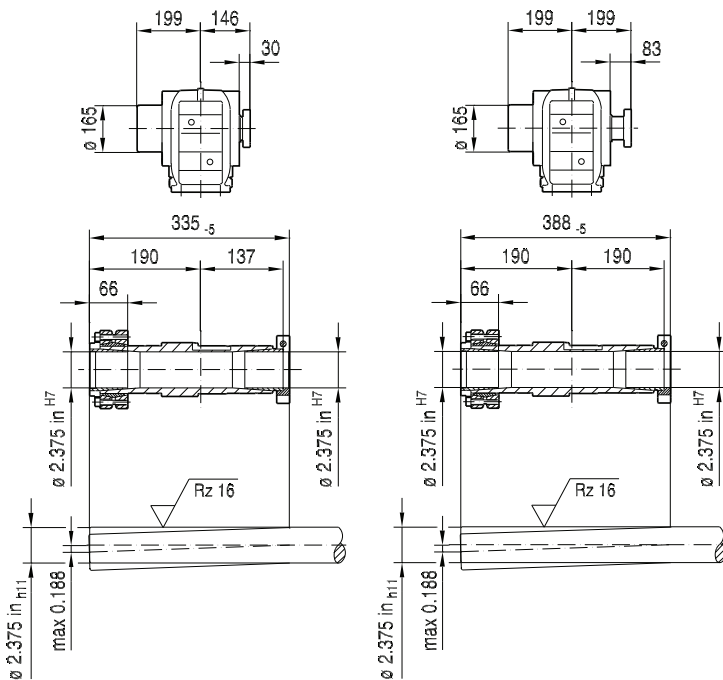

10

(→ 132)	B	B5	C5	E5	F5	G5	L	L1	L5	S5	T1	U	U1	Z5
AM143	1.68 in	4.50 in	12	5.875 in	4.5	170	489	2.25 in	0.13 in	10.5	0.98 in	0.875 in	0.188 in	98.5
AM145	1.68 in	4.50 in	12	5.875 in	4.5	170	489	2.25 in	0.13 in	10.5	0.98 in	0.875 in	0.188 in	98.5
AM182	2.10 in	8.50 in	10	7.25 in	5	228	525	2.75 in	0.13 in	15	1.24 in	1.125 in	0.250 in	134.5
AM184	2.10 in	8.50 in	10	7.25 in	5	228	525	2.75 in	0.13 in	15	1.24 in	1.125 in	0.250 in	134.5
AM213/215	2.76 in	8.50 in	11	7.25 in	5	228	574	3.38 in	0.25 in	15	1.52 in	1.375 in	0.312 in	183.5
AM254/256	3.65 in	8.50 in	14	7.25 in	5	228	624	4.00 in	0.25 in	15	1.80 in	1.625 in	0.375 in	234
AM284/286	4.00 in	10.50 in	15	9.00 in	5	286	631	4.62 in	0.25 in	15	2.10 in	1.875 in	0.500 in	241

Note: Dimensions in mm unless otherwise noted. For all available output shaft diameters, see page 577. For dimensions of compound gear units (ex: KA87R57) see page 565.

10 K - Helical Bevel

K.. AM.. [NEMA dimensions]

33 038 00 11

K97..

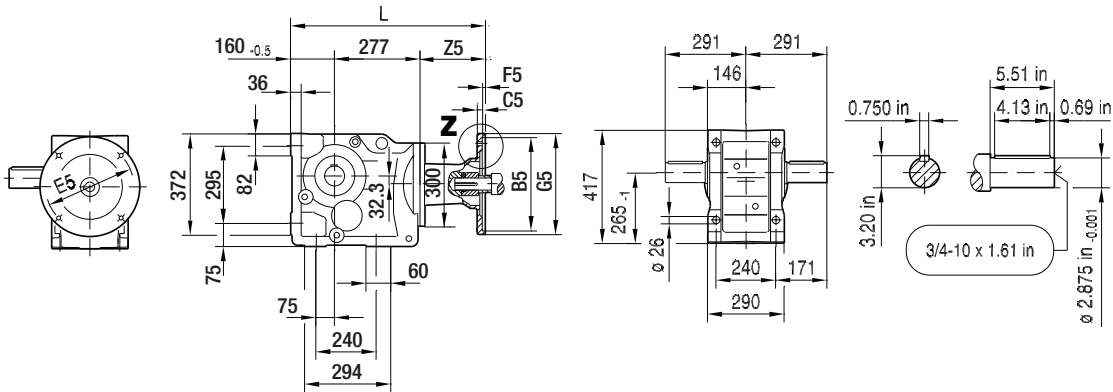

KA97B..

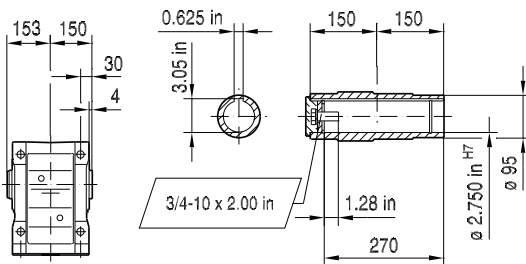

KV97B..

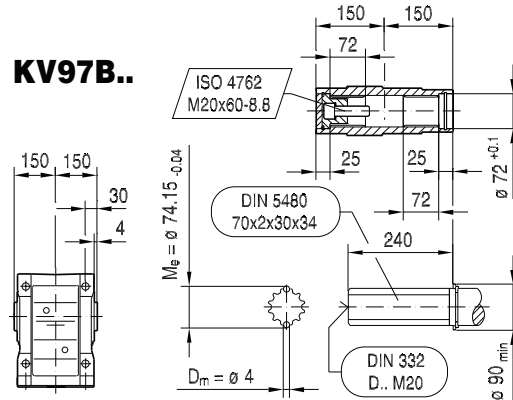

KH97B..

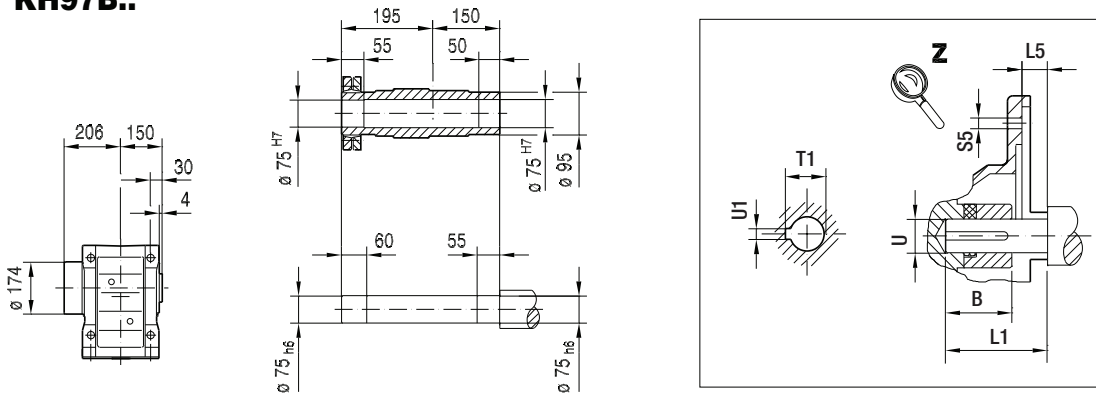

(→ 132)	B	B5	C5	E5	F5	G5	L	L1	L5	S5	T1	U	U1	Z5
AM182	2.10 in	8.50 in	10	7.25 in	5	228	567	2.75 in	0.13 in	15	1.24 in	1.125 in	0.250 in	129.5
AM184	2.10 in	8.50 in	10	7.25 in	5	228	567	2.75 in	0.13 in	15	1.24 in	1.125 in	0.250 in	129.5
AM213/215	2.76 in	8.50 in	11	7.25 in	5	228	616	3.38 in	0.25 in	15	1.52 in	1.375 in	0.312 in	178.5
AM254/256	3.65 in	8.50 in	12	7.25 in	5	228	666	4.00 in	0.25 in	15	1.80 in	1.625 in	0.375 in	229
AM284/286	4.00 in	10.50 in	15	9.00 in	5	286	673	4.62 in	0.25 in	15	2.10 in	1.875 in	0.500 in	236
AM324/326	3.88 in	12.50 in	17	11.0 in	5	356	733	5.25 in	0.25 in	17.5	2.36 in	2.125 in	0.500 in	296
AM364/365	4.51 in	12.50 in	17	11.0 in	5	356	733	5.88 in	0.25 in	17.5	2.66 in	2.375 in	0.625 in	296

Note: Dimensions in mm unless otherwise noted. For all available output shaft diameters, see page 573. For dimensions of compound gear units (ex: K97R57) see page 565.

KF97..

33 039 00 11

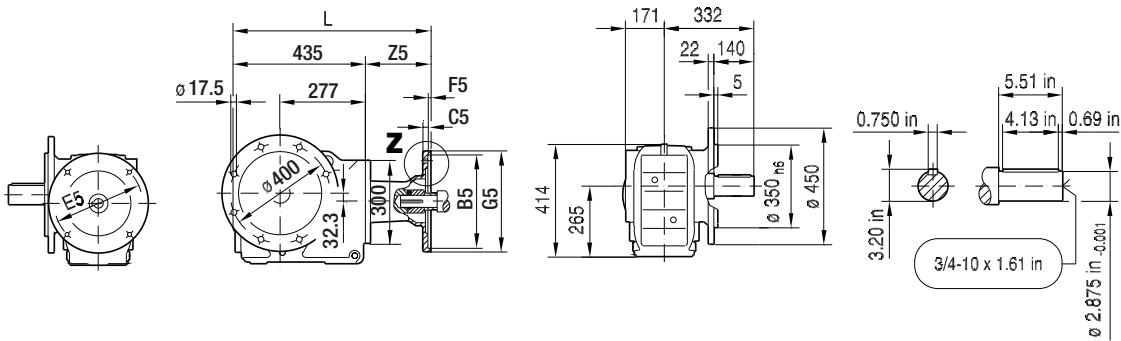

KAF97..

KVF97..

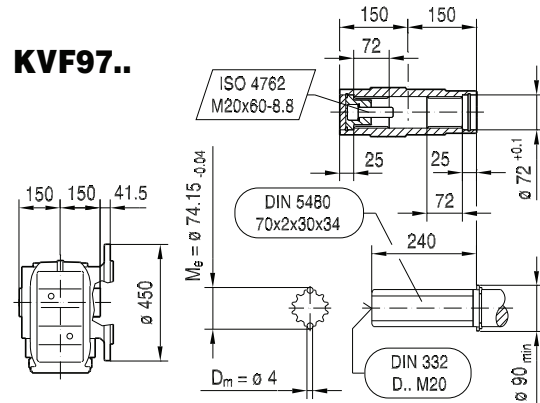
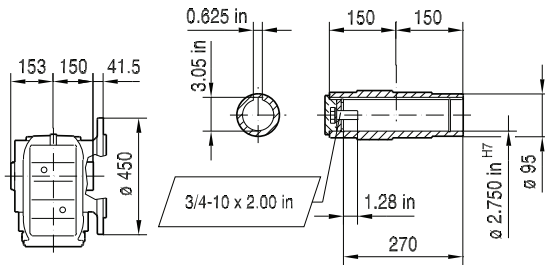

KHF97..

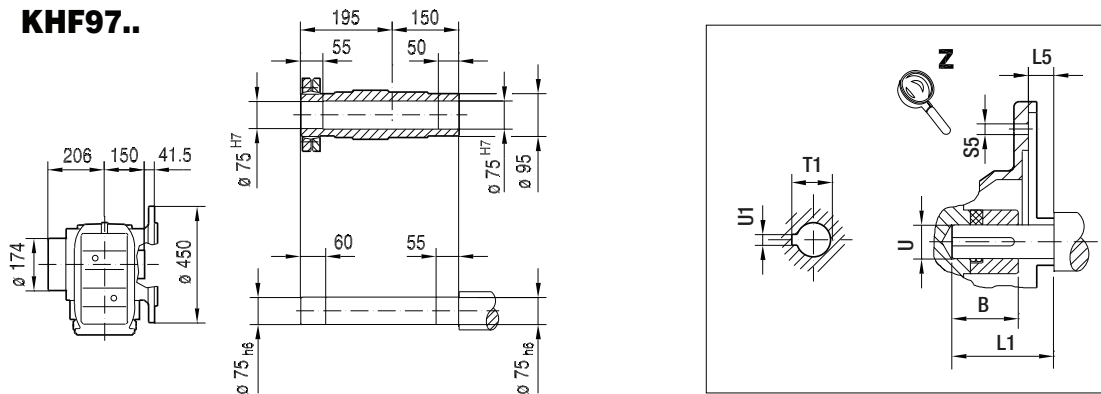

(→ 132)	B	B5	C5	E5	F5	G5	L	L1	L5	S5	T1	U	U1	Z5
AM182	2.10 in	8.50 in	10	7.25 in	5	228	565	2.75 in	0.13 in	15	1.24 in	1.125 in	0.250 in	129.5
AM184	2.10 in	8.50 in	10	7.25 in	5	228	565	2.75 in	0.13 in	15	1.24 in	1.125 in	0.250 in	129.5
AM213/215	2.76 in	8.50 in	11	7.25 in	5	228	614	3.38 in	0.25 in	15	1.52 in	1.375 in	0.312 in	178.5
AM254/256	3.65 in	8.50 in	12	7.25 in	5	228	664	4.00 in	0.25 in	15	1.80 in	1.625 in	0.375 in	229
AM284/286	4.00 in	10.50 in	15	9.00 in	5	286	671	4.62 in	0.25 in	15	2.10 in	1.875 in	0.500 in	236
AM324/326	3.88 in	12.50 in	17	11.0 in	5	356	731	5.25 in	0.25 in	17.5	2.36 in	2.125 in	0.500 in	296
AM364/365	4.51 in	12.50 in	17	11.0 in	5	356	731	5.88 in	0.25 in	17.5	2.66 in	2.375 in	0.625 in	296

Note: Dimensions in mm unless otherwise noted. For all available output shaft diameters, see page 573. For dimensions of compound gear units (ex: KF97R57) see page 565.

10 K - Helical Bevel

K.. AM.. [NEMA dimensions]

KA97..

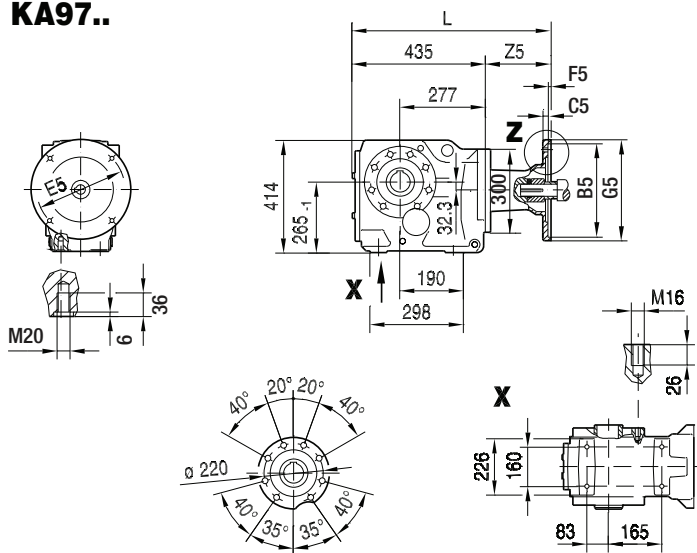

33 040 00 11

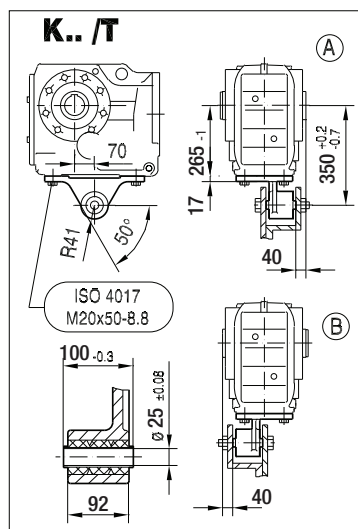

KA97..

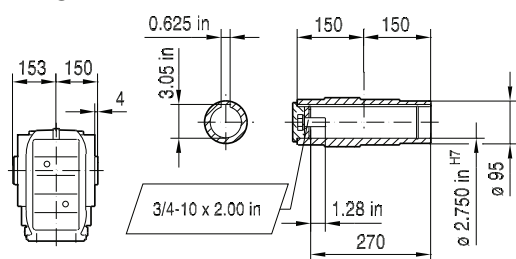

KV97..

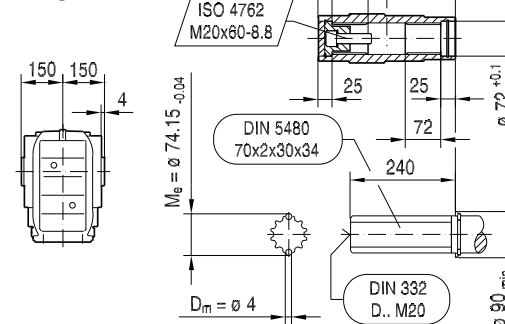

KH97..

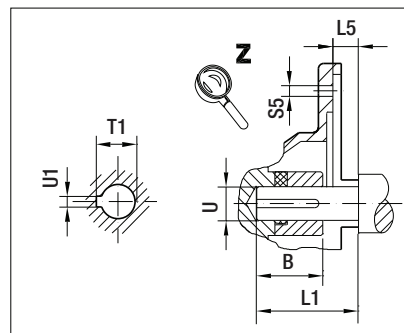
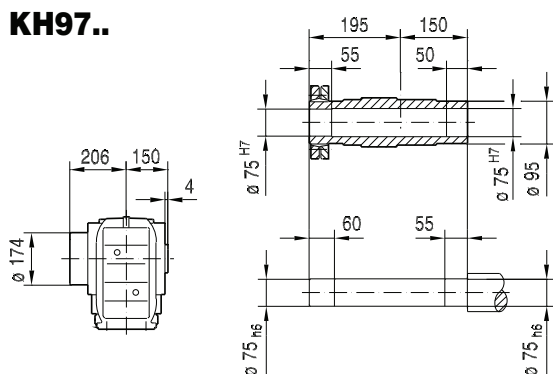

(→ 132)	B	B5	C5	E5	F5	G5	L	L1	L5	S5	T1	U	U1	Z5
AM182	2.10 in	8.50 in	10	7.25 in	5	228	565	2.75 in	0.13 in	15	1.24 in	1.125 in	0.250 in	129.5
AM184	2.10 in	8.50 in	10	7.25 in	5	228	565	2.75 in	0.13 in	15	1.24 in	1.125 in	0.250 in	129.5
AM213/215	2.76 in	8.50 in	11	7.25 in	5	228	614	3.38 in	0.25 in	15	1.52 in	1.375 in	0.312 in	178.5
AM254/256	3.65 in	8.50 in	12	7.25 in	5	228	664	4.00 in	0.25 in	15	1.80 in	1.625 in	0.375 in	229
AM284/286	4.00 in	10.50 in	15	9.00 in	5	286	671	4.62 in	0.25 in	15	2.10 in	1.875 in	0.500 in	236
AM324/326	3.88 in	12.50 in	17	11.0 in	5	356	731	5.25 in	0.25 in	17.5	2.36 in	2.125 in	0.500 in	296
AM364/365	4.51 in	12.50 in	17	11.0 in	5	356	731	5.88 in	0.25 in	17.5	2.66 in	2.375 in	0.625 in	296

Note: Dimensions in mm unless otherwise noted. For all available output shaft diameters, see page 575. For dimensions of compound gear units (ex: KA97R57) see page 565.

KAZ97..

33 041 00 11

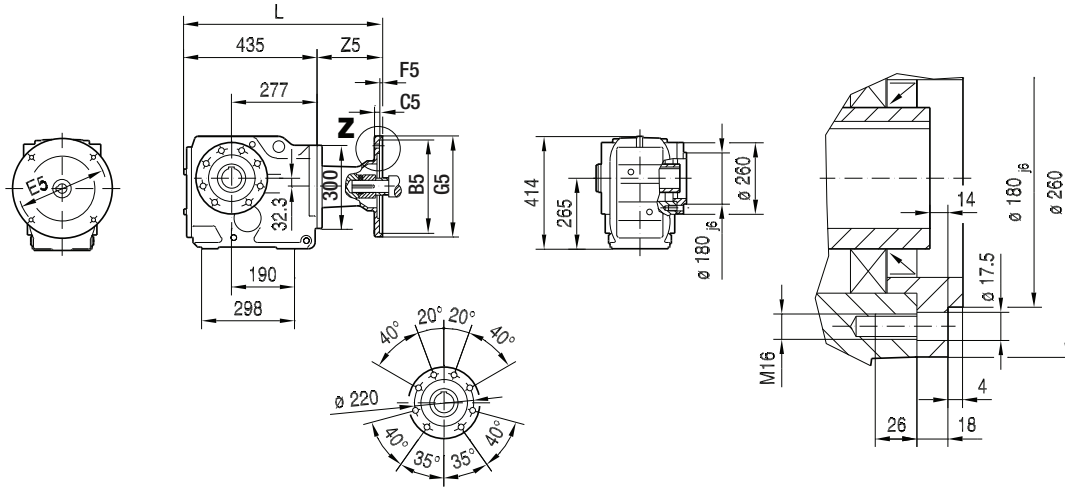

KAZ97..

KVZ97..

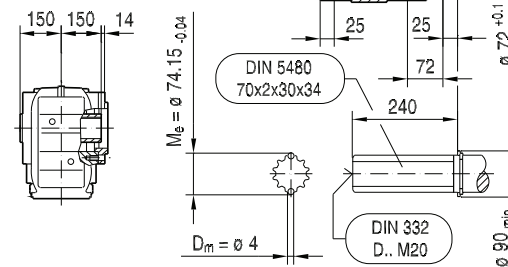
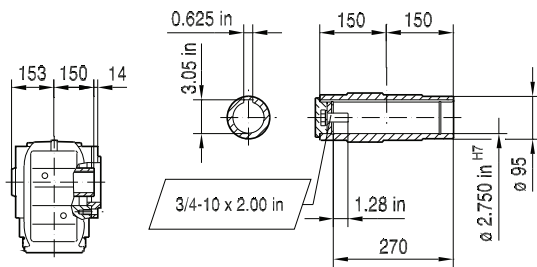

KHZ97..

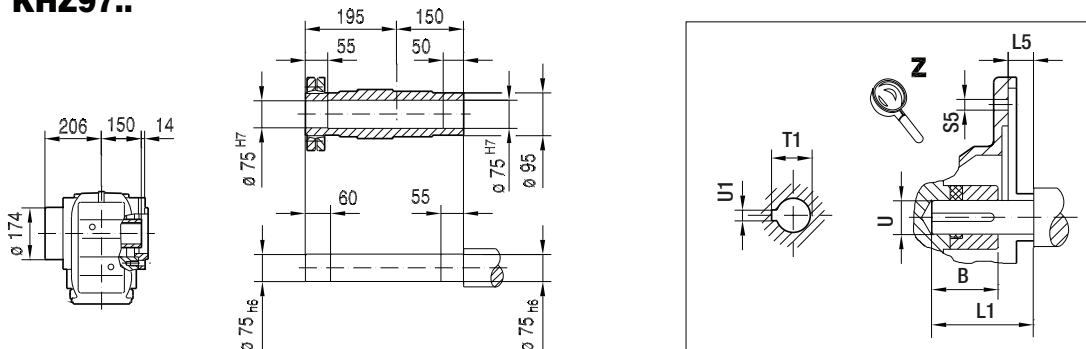

(→ 132)	B	B5	C5	E5	F5	G5	L	L1	L5	S5	T1	U	U1	Z5
AM182	2.10 in	8.50 in	10	7.25 in	5	228	565	2.75 in	0.13 in	15	1.24 in	1.125 in	0.250 in	129.5
AM184	2.10 in	8.50 in	10	7.25 in	5	228	565	2.75 in	0.13 in	15	1.24 in	1.125 in	0.250 in	129.5
AM213/215	2.76 in	8.50 in	11	7.25 in	5	228	614	3.38 in	0.25 in	15	1.52 in	1.375 in	0.312 in	178.5
AM254/256	3.65 in	8.50 in	12	7.25 in	5	228	664	4.00 in	0.25 in	15	1.80 in	1.625 in	0.375 in	229
AM284/286	4.00 in	10.50 in	15	9.00 in	5	286	671	4.62 in	0.25 in	15	2.10 in	1.875 in	0.500 in	236
AM324/326	3.88 in	12.50 in	17	11.0 in	5	356	731	5.25 in	0.25 in	17.5	2.36 in	2.125 in	0.500 in	296
AM364/365	4.51 in	12.50 in	17	11.0 in	5	356	731	5.88 in	0.25 in	17.5	2.66 in	2.375 in	0.625 in	296

Note: Dimensions in mm unless otherwise noted. For all available output shaft diameters, see page 575. For dimensions of compound gear units (ex: KAZ97R57) see page 565.

10 K - Helical Bevel

K.. AM.. [NEMA dimensions]

KT97..

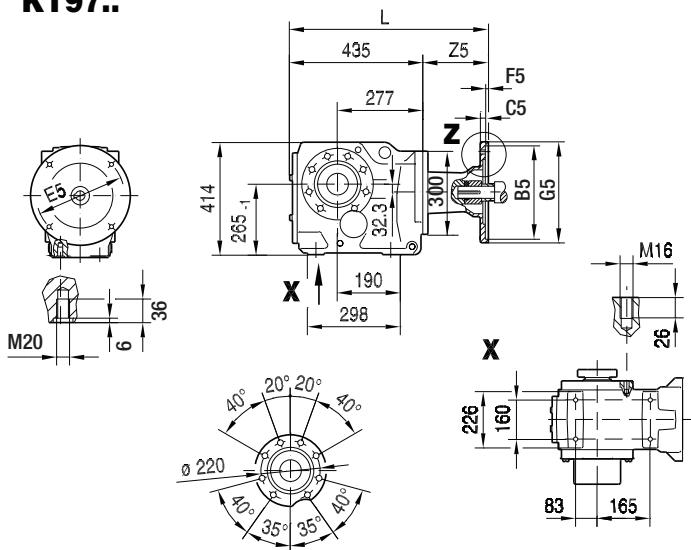

33 042 00 11

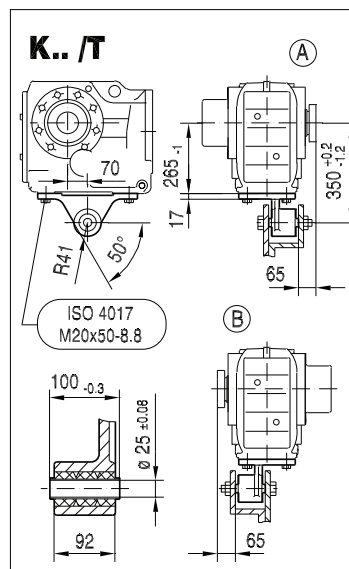

NON-Symmetrical

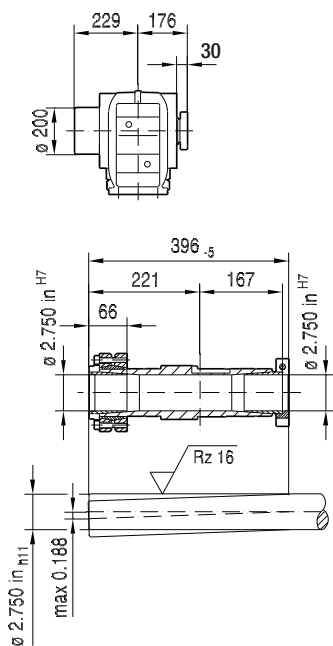

Symmetrical

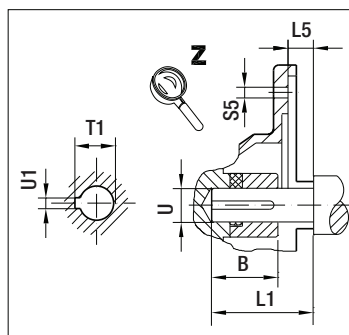
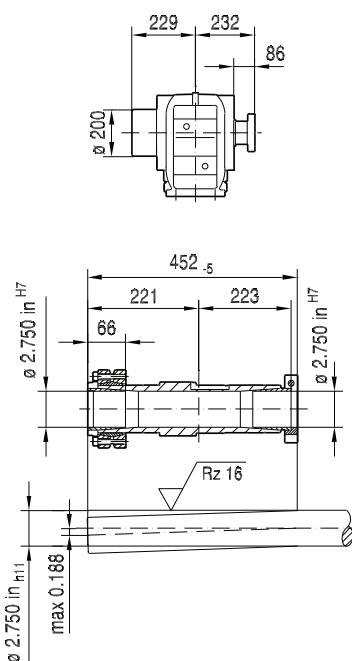

(→ 132)	B	B5	C5	E5	F5	G5	L	L1	L5	S5	T1	U	U1	Z5
AM182	2.10 in	8.50 in	10	7.25 in	5	228	565	2.75 in	0.13 in	15	1.24 in	1.125 in	0.250 in	129.5
AM184	2.10 in	8.50 in	10	7.25 in	5	228	565	2.75 in	0.13 in	15	1.24 in	1.125 in	0.250 in	129.5
AM213/215	2.76 in	8.50 in	11	7.25 in	5	228	614	3.38 in	0.25 in	15	1.52 in	1.375 in	0.312 in	178.5
AM254/256	3.65 in	8.50 in	12	7.25 in	5	228	664	4.00 in	0.25 in	15	1.80 in	1.625 in	0.375 in	229
AM284/286	4.00 in	10.50 in	15	9.00 in	5	286	671	4.62 in	0.25 in	15	2.10 in	1.875 in	0.500 in	236
AM324/326	3.88 in	12.50 in	17	11.0 in	5	356	731	5.25 in	0.25 in	17.5	2.36 in	2.125 in	0.500 in	296
AM364/365	4.51 in	12.50 in	17	11.0 in	5	356	731	5.88 in	0.25 in	17.5	2.66 in	2.375 in	0.625 in	296

Note: Dimensions in mm unless otherwise noted. For all available output shaft diameters, see page 577. For dimensions of compound gear units (ex: KT97R57) see page 565.

33 043 00 11

K107..

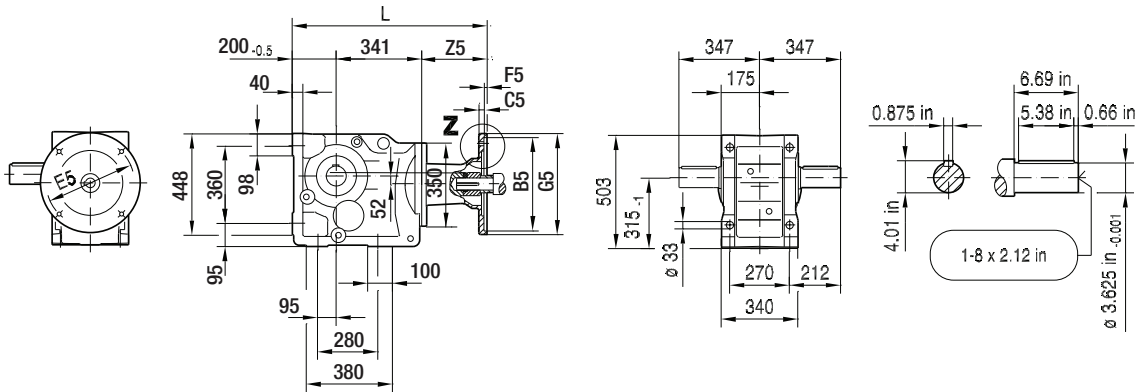

KA107B..

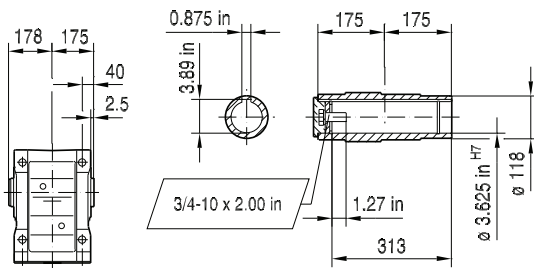

KV107B..

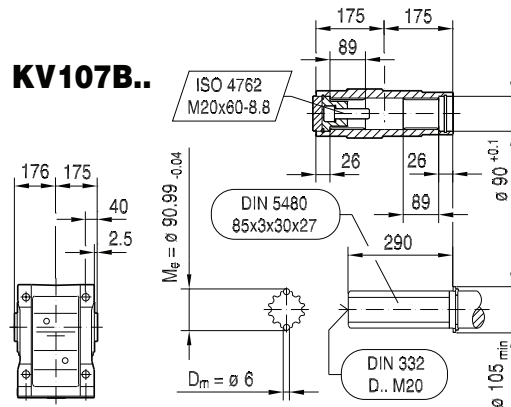

KH107B..

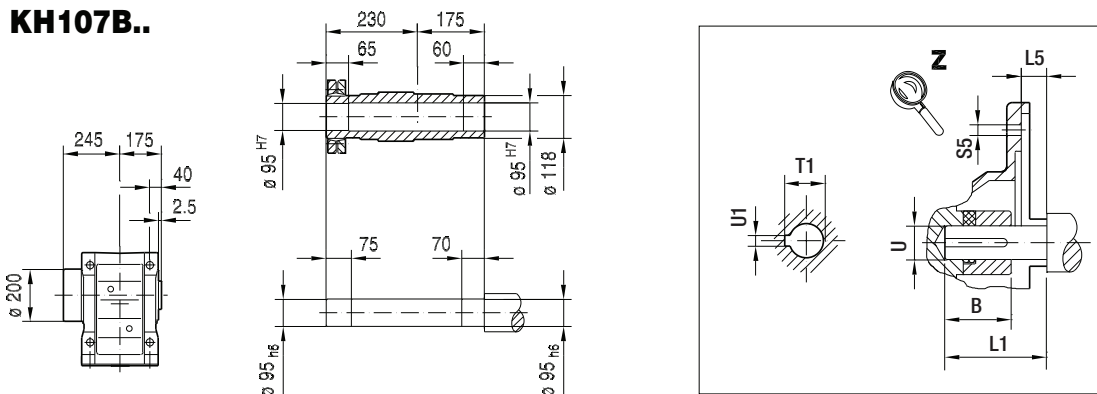

(→ 132)	B	B5	C5	E5	F5	G5	L	L1	L5	S5	T1	U	U1	Z5
AM182	2.10 in	8.50 in	10	7.25 in	5	228	665	2.75 in	0.13 in	15	1.24 in	1.125 in	0.250 in	123.5
AM184	2.10 in	8.50 in	10	7.25 in	5	228	665	2.75 in	0.13 in	15	1.24 in	1.125 in	0.250 in	123.5
AM213/215	2.76 in	8.50 in	11	7.25 in	5	228	714	3.38 in	0.25 in	15	1.52 in	1.375 in	0.312 in	172.5
AM254/256	3.65 in	8.50 in	12	7.25 in	5	228	764	4.00 in	0.25 in	15	1.80 in	1.625 in	0.375 in	223
AM284/286	4.00 in	10.50 in	15	9.00 in	5	286	771	4.62 in	0.25 in	15	2.10 in	1.875 in	0.500 in	230
AM324/326	3.88 in	12.50 in	17	11.0 in	5	356	831	5.25 in	0.25 in	17.5	2.36 in	2.125 in	0.500 in	290
AM364/365	4.51 in	12.50 in	17	11.0 in	5	356	831	5.88 in	0.25 in	17.5	2.66 in	2.375 in	0.625 in	290

Note: Dimensions in mm unless otherwise noted. For all available output shaft diameters, see page 573. For dimensions of compound gear units (ex: K107R77) see page 565.

10 K - Helical Bevel

K.. AM.. [NEMA dimensions]

33 044 00 11

KF107..

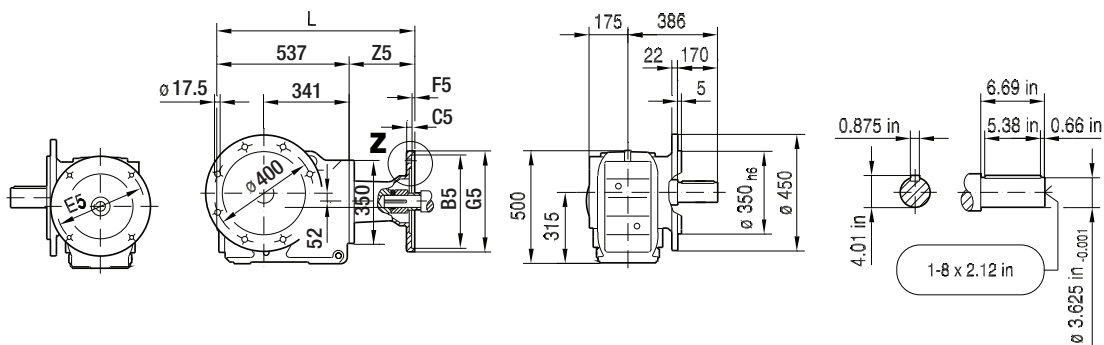

KAF107..

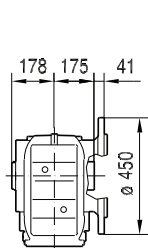

KVF107..

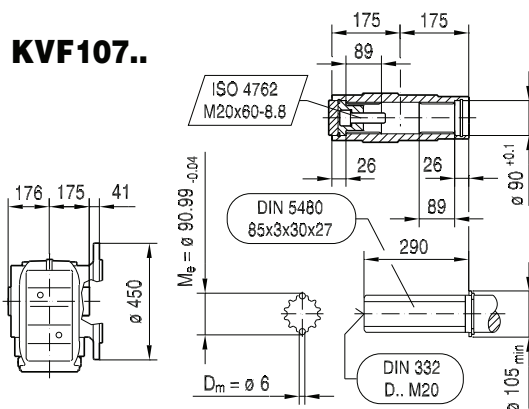

KHF107..

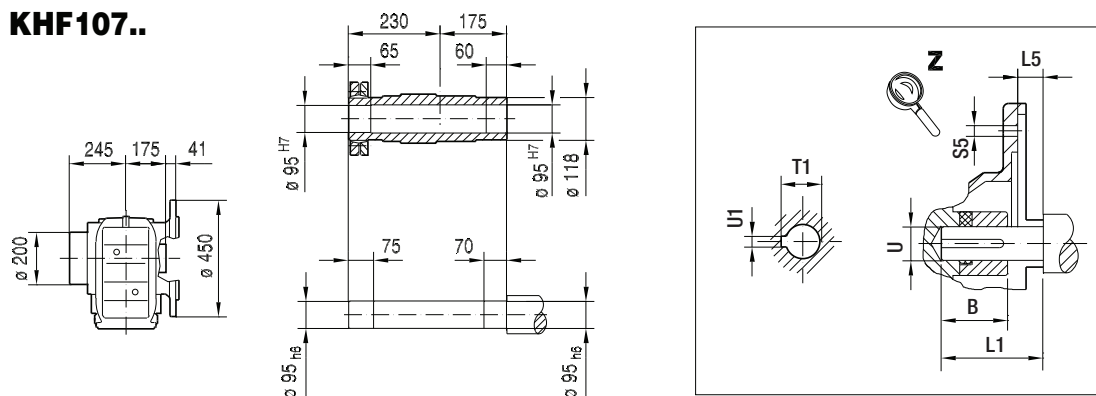

(→ 132)	B	B5	C5	E5	F5	G5	L	L1	L5	S5	T1	U	U1	Z5
AM182	2.10 in	8.50 in	10	7.25 in	5	228	661	2.75 in	0.13 in	15	1.24 in	1.125 in	0.250 in	123.5
AM184	2.10 in	8.50 in	10	7.25 in	5	228	661	2.75 in	0.13 in	15	1.24 in	1.125 in	0.250 in	123.5
AM213/215	2.76 in	8.50 in	11	7.25 in	5	228	710	3.38 in	0.25 in	15	1.52 in	1.375 in	0.312 in	172.5
AM254/256	3.65 in	8.50 in	12	7.25 in	5	228	760	4.00 in	0.25 in	15	1.80 in	1.625 in	0.375 in	223
AM284/286	4.00 in	10.50 in	15	9.00 in	5	286	767	4.62 in	0.25 in	15	2.10 in	1.875 in	0.500 in	230
AM324/326	3.88 in	12.50 in	17	11.0 in	5	356	827	5.25 in	0.25 in	17.5	2.36 in	2.125 in	0.500 in	290
AM364/365	4.51 in	12.50 in	17	11.0 in	5	356	827	5.88 in	0.25 in	17.5	2.66 in	2.375 in	0.625 in	290

Note: Dimensions in mm unless otherwise noted. For all available output shaft diameters, see page 573. For dimensions of compound gear units (ex: KF107R77) see page 565.

KA107..

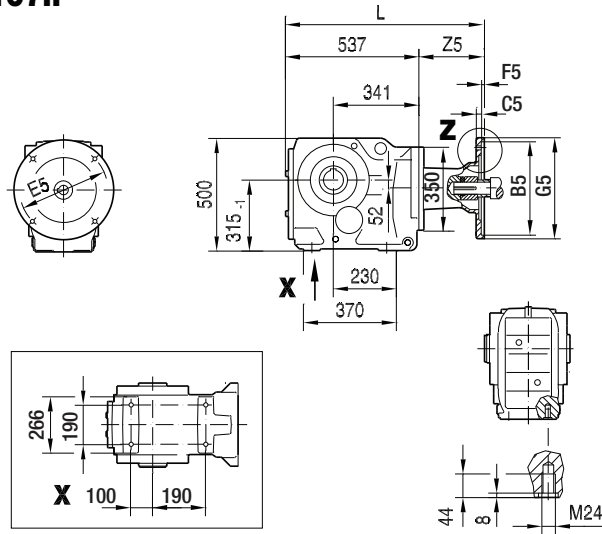

33 045 00 11

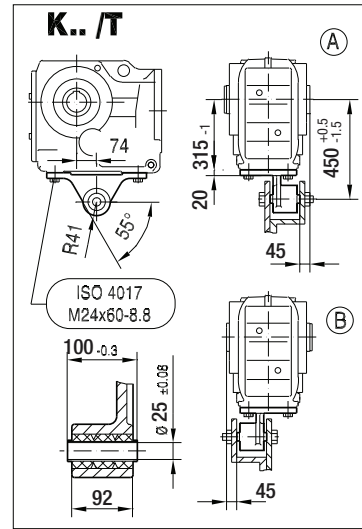

KA107..

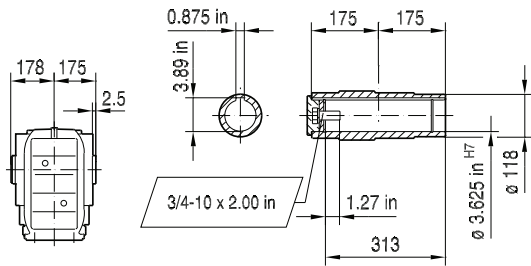

KV107..

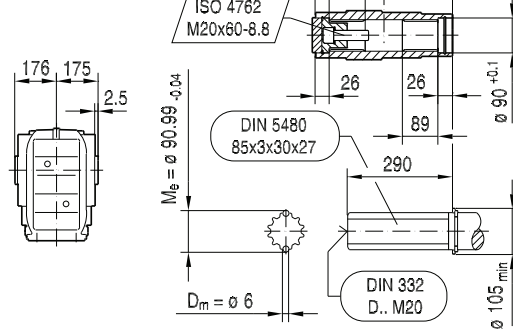

KH107..

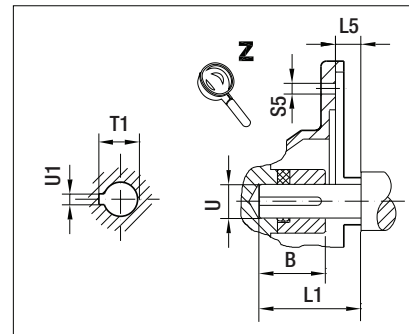
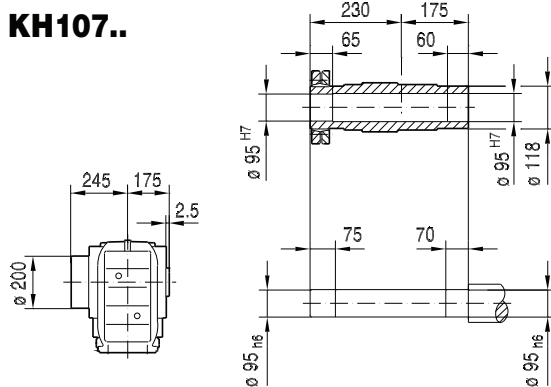

(→ 132)	B	B5	C5	E5	F5	G5	L	L1	L5	S5	T1	U	U1	Z5
AM182	2.10 in	8.50 in	10	7.25 in	5	228	661	2.75 in	0.13 in	15	1.24 in	1.125 in	0.250 in	123.5
AM184	2.10 in	8.50 in	10	7.25 in	5	228	661	2.75 in	0.13 in	15	1.24 in	1.125 in	0.250 in	123.5
AM213/215	2.76 in	8.50 in	11	7.25 in	5	228	710	3.38 in	0.25 in	15	1.52 in	1.375 in	0.312 in	172.5
AM254/256	3.65 in	8.50 in	12	7.25 in	5	228	760	4.00 in	0.25 in	15	1.80 in	1.625 in	0.375 in	223
AM284/286	4.00 in	10.50 in	15	9.00 in	5	286	767	4.62 in	0.25 in	15	2.10 in	1.875 in	0.500 in	230
AM324/326	3.88 in	12.50 in	17	11.0 in	5	356	827	5.25 in	0.25 in	17.5	2.36 in	2.125 in	0.500 in	290
AM364/365	4.51 in	12.50 in	17	11.0 in	5	356	827	5.88 in	0.25 in	17.5	2.66 in	2.375 in	0.625 in	290

Note: Dimensions in mm unless otherwise noted. For all available output shaft diameters, see page 575. For dimensions of compound gear units (ex: KA107R77) see page 565.

10 K - Helical Bevel

K.. AM.. [NEMA dimensions]

33 046 00 11

KAZ107..

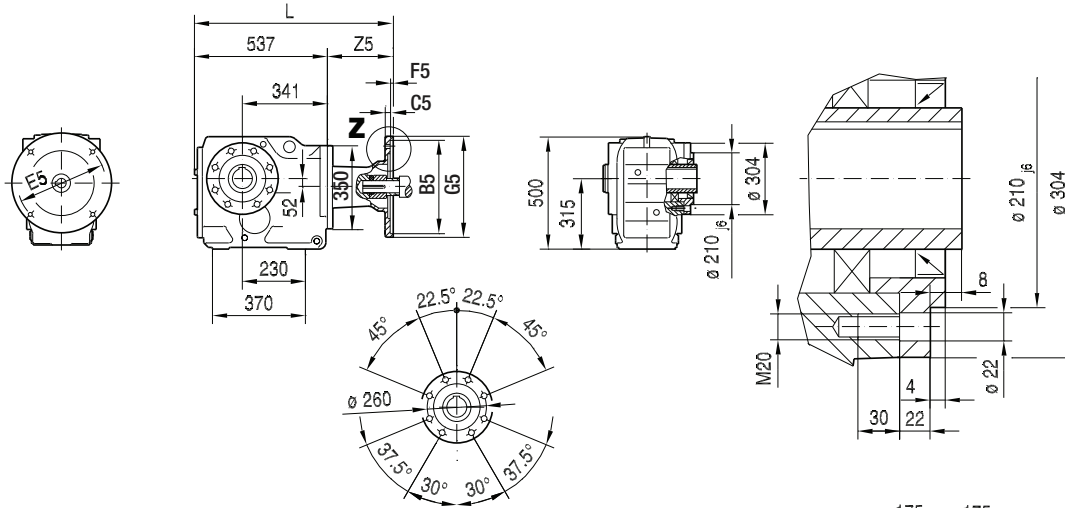

KAZ107..

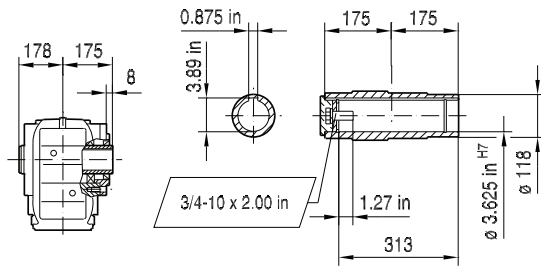

KVZ107..

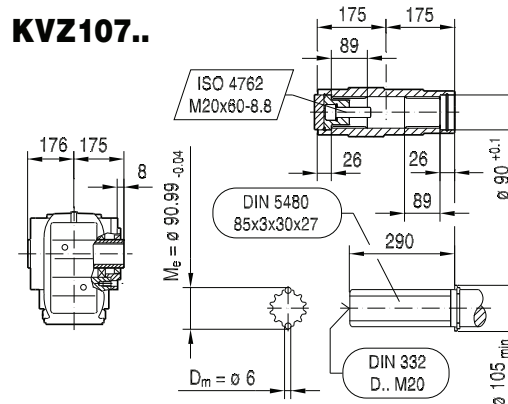

KHZ107..

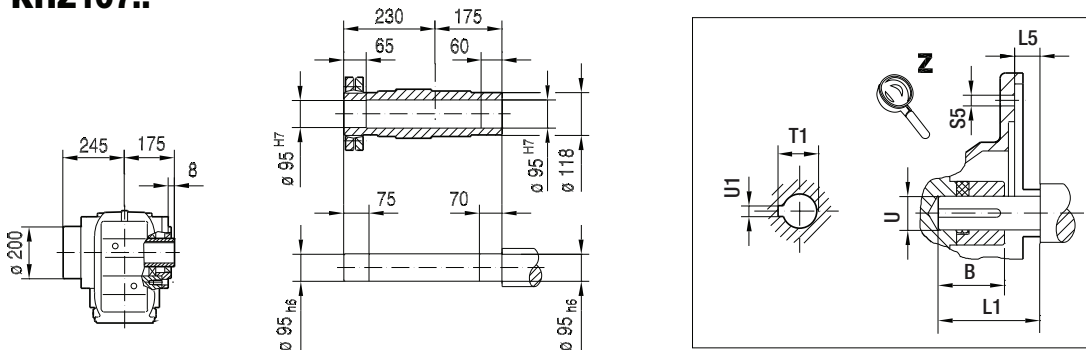

(→ 132)	B	B5	C5	E5	F5	G5	L	L1	L5	S5	T1	U	U1	Z5
AM182	2.10 in	8.50 in	10	7.25 in	5	228	661	2.75 in	0.13 in	15	1.24 in	1.125 in	0.250 in	123.5
AM184	2.10 in	8.50 in	10	7.25 in	5	228	661	2.75 in	0.13 in	15	1.24 in	1.125 in	0.250 in	123.5
AM213/215	2.76 in	8.50 in	11	7.25 in	5	228	710	3.38 in	0.25 in	15	1.52 in	1.375 in	0.312 in	172.5
AM254/256	3.65 in	8.50 in	12	7.25 in	5	228	760	4.00 in	0.25 in	15	1.80 in	1.625 in	0.375 in	223
AM284/286	4.00 in	10.50 in	15	9.00 in	5	286	767	4.62 in	0.25 in	15	2.10 in	1.875 in	0.500 in	230
AM324/326	3.88 in	12.50 in	17	11.0 in	5	356	827	5.25 in	0.25 in	17.5	2.36 in	2.125 in	0.500 in	290
AM364/365	4.51 in	12.50 in	17	11.0 in	5	356	827	5.88 in	0.25 in	17.5	2.66 in	2.375 in	0.625 in	290

Note: Dimensions in mm unless otherwise noted. For all available output shaft diameters, see page 575. For dimensions of compound gear units (ex: KAZ107R77) see page 565.

KT107..

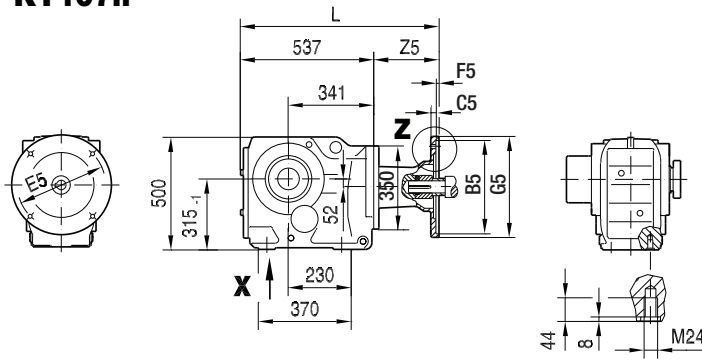

33 047 00 11

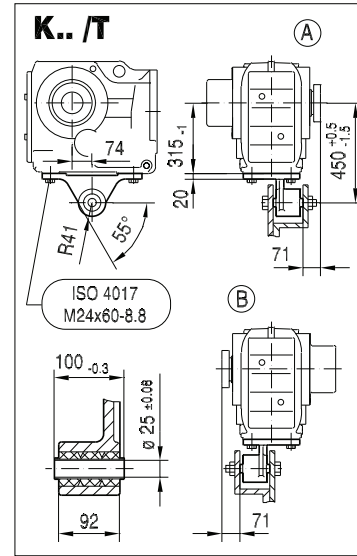

NON-Symmetrical

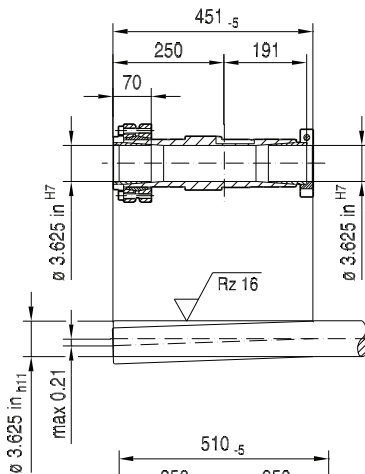
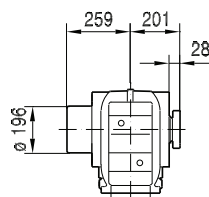

Symmetrical

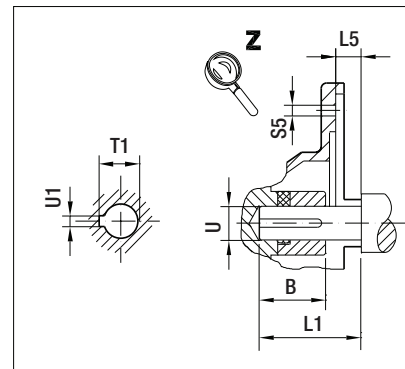
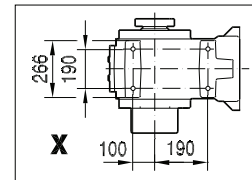
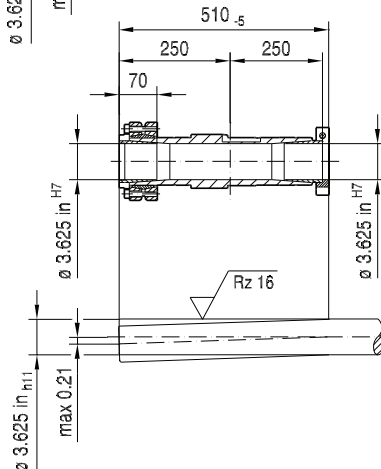
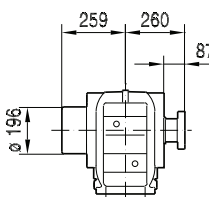

(→ 132)	B	B5	C5	E5	F5	G5	L	L1	L5	S5	T1	U	U1	Z5
AM182	2.10 in	8.50 in	10	7.25 in	5	228	661	2.75 in	0.13 in	15	1.24 in	1.125 in	0.250 in	123.5
AM184	2.10 in	8.50 in	10	7.25 in	5	228	661	2.75 in	0.13 in	15	1.24 in	1.125 in	0.250 in	123.5
AM213/215	2.76 in	8.50 in	11	7.25 in	5	228	710	3.38 in	0.25 in	15	1.52 in	1.375 in	0.312 in	172.5
AM254/256	3.65 in	8.50 in	12	7.25 in	5	228	760	4.00 in	0.25 in	15	1.80 in	1.625 in	0.375 in	223
AM284/286	4.00 in	10.50 in	15	9.00 in	5	286	767	4.62 in	0.25 in	15	2.10 in	1.875 in	0.500 in	230
AM324/326	3.88 in	12.50 in	17	11.0 in	5	356	827	5.25 in	0.25 in	17.5	2.36 in	2.125 in	0.500 in	290
AM364/365	4.51 in	12.50 in	17	11.0 in	5	356	827	5.88 in	0.25 in	17.5	2.66 in	2.375 in	0.625 in	290

Note: Dimensions in mm unless otherwise noted. For all available output shaft diameters, see page 577. For dimensions of compound gear units (ex: KT107R77) see page 565.

10 K - Helical Bevel

K.. AM.. [NEMA dimensions]

33 048 00 11

K127..

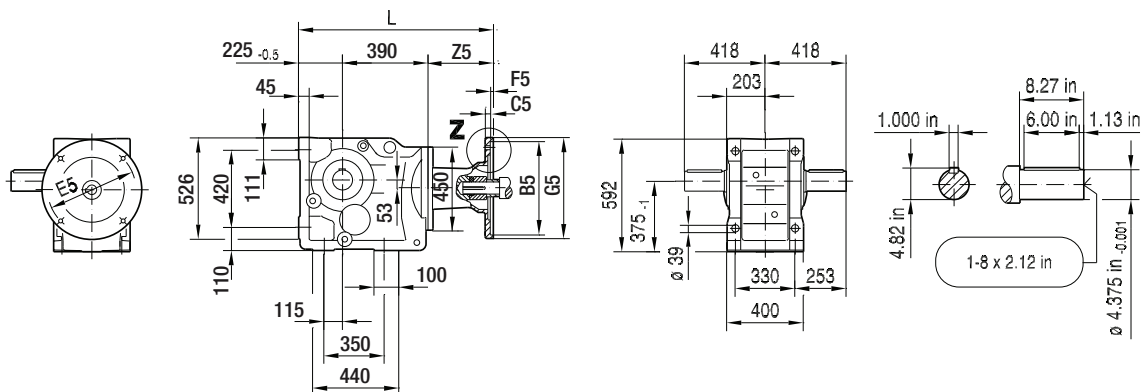

KA127B..

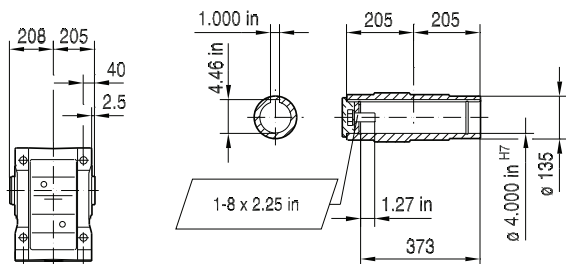

KH127B..

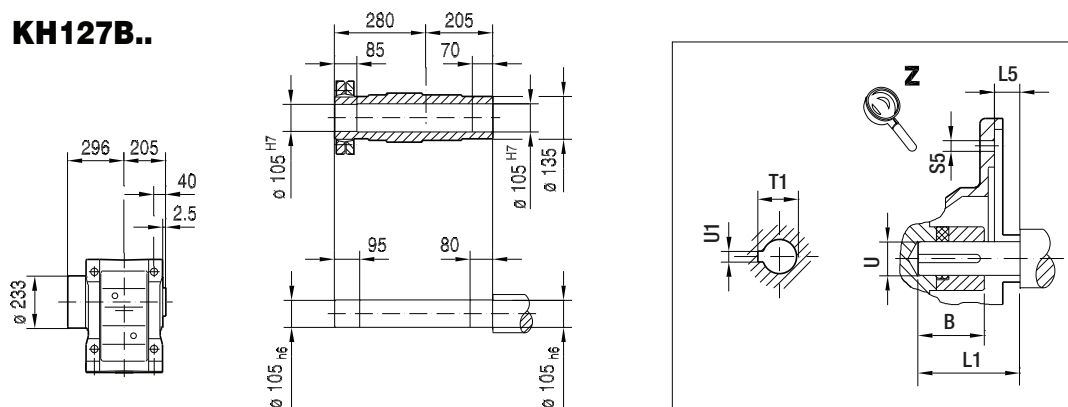

(→ 132)	B	B5	C5	E5	F5	G5	L	L1	L5	S5	T1	U	U1	Z5
AM213/215	2.76 in	8.50 in	11	7.25 in	5	228	773	3.38 in	0.25 in	15	1.52 in	1.375 in	0.312 in	157.5
AM254/256	3.65 in	8.50 in	12	7.25 in	5	228	823	4.00 in	0.25 in	15	1.80 in	1.625 in	0.375 in	208
AM284/286	4.00 in	10.50 in	15	9.00 in	5	286	830	4.62 in	0.25 in	15	2.10 in	1.875 in	0.500 in	215
AM324/326	3.88 in	12.50 in	17	11.0 in	5	356	890	5.25 in	0.25 in	17.5	2.36 in	2.125 in	0.500 in	275
AM364/365	4.51 in	12.50 in	17	11.0 in	5	356	890	5.88 in	0.25 in	17.5	2.66 in	2.375 in	0.625 in	275

Note: Dimensions in mm unless otherwise noted. For all available output shaft diameters, see page 573. For dimensions of compound gear units (ex: K127R77) see page 565.

KF127..

33 049 00 11

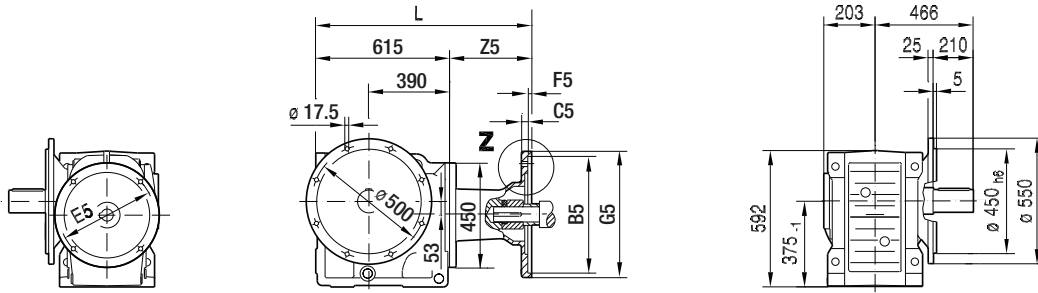

KAF127..

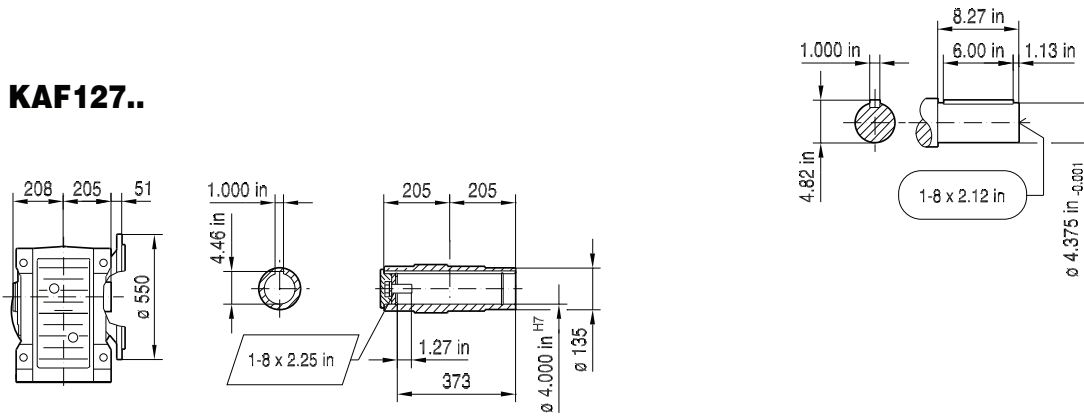

KHF127..

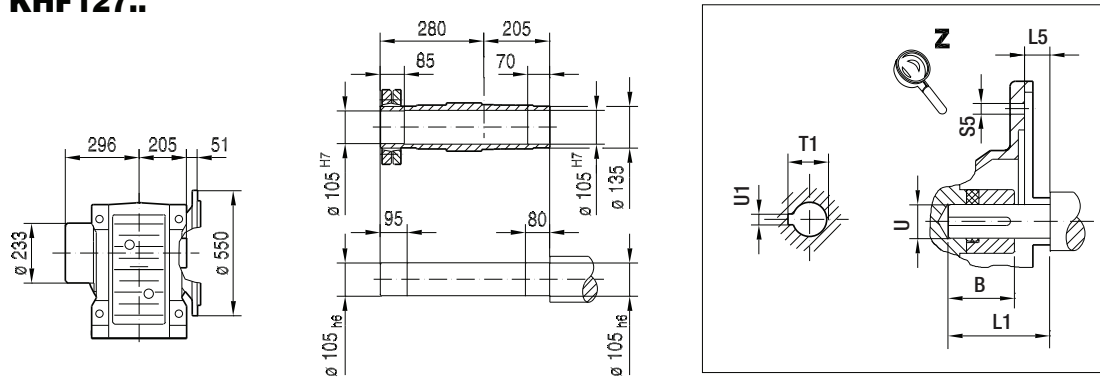

(→ 132)	B	B5	C5	E5	F5	G5	L	L1	L5	S5	T1	U	U1	Z5
AM213/215	2.76 in	8.50 in	11	7.25 in	5	228	773	3.38 in	0.25 in	15	1.52 in	1.375 in	0.312 in	157.5
AM254/256	3.65 in	8.50 in	12	7.25 in	5	228	823	4.00 in	0.25 in	15	1.80 in	1.625 in	0.375 in	208
AM284/286	4.00 in	10.50 in	15	9.00 in	5	286	830	4.62 in	0.25 in	15	2.10 in	1.875 in	0.500 in	215
AM324/326	3.88 in	12.50 in	17	11.0 in	5	356	890	5.25 in	0.25 in	17.5	2.36 in	2.125 in	0.500 in	275
AM364/365	4.51 in	12.50 in	17	11.0 in	5	356	890	5.88 in	0.25 in	17.5	2.66 in	2.375 in	0.625 in	275

Note: Dimensions in mm unless otherwise noted. For all available output shaft diameters, see page 573. For dimensions of compound gear units (ex: KF127R77) see page 565.

10 K - Helical Bevel

K.. AM.. [NEMA dimensions]

KA127..

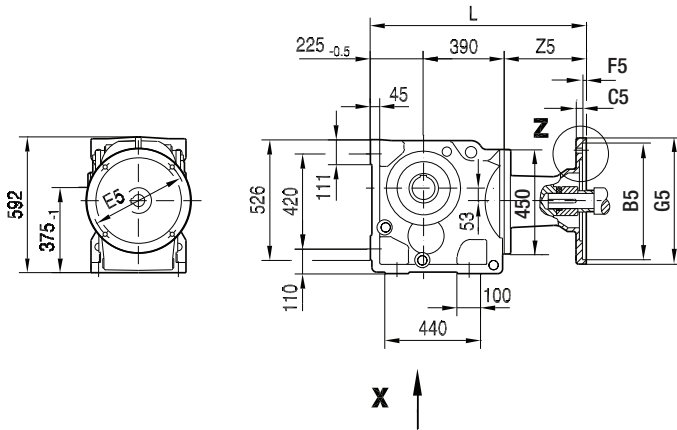

33 050 00 11

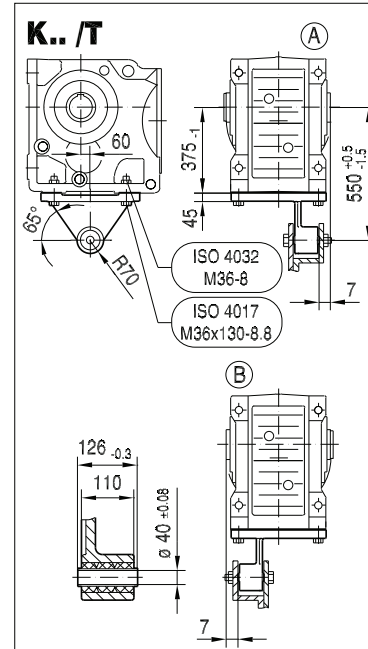

KA127..

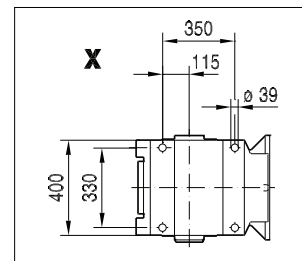
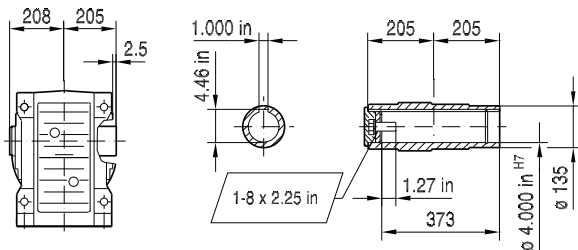

KH127..

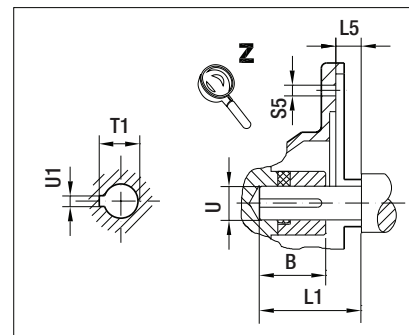
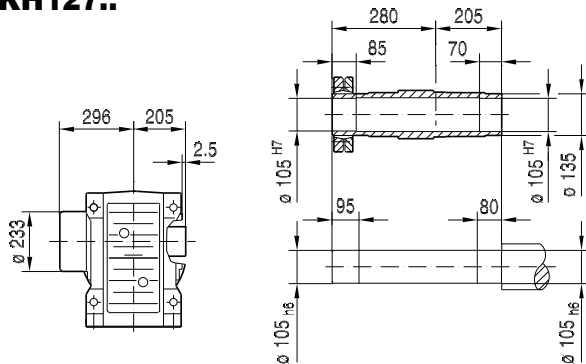

(→ 132)	B	B5	C5	E5	F5	G5	L	L1	L5	S5	T1	U	U1	Z5
AM213/215	2.76 in	8.50 in	11	7.25 in	5	228	773	3.38 in	0.25 in	15	1.52 in	1.375 in	0.312 in	157.5
AM254/256	3.65 in	8.50 in	12	7.25 in	5	228	823	4.00 in	0.25 in	15	1.80 in	1.625 in	0.375 in	208
AM284/286	4.00 in	10.50 in	15	9.00 in	5	286	830	4.62 in	0.25 in	15	2.10 in	1.875 in	0.500 in	215
AM324/326	3.88 in	12.50 in	17	11.0 in	5	356	890	5.25 in	0.25 in	17.5	2.36 in	2.125 in	0.500 in	275
AM364/365	4.51 in	12.50 in	17	11.0 in	5	356	890	5.88 in	0.25 in	17.5	2.66 in	2.375 in	0.625 in	275

Note: Dimensions in mm unless otherwise noted. For all available output shaft diameters, see page 575. For dimensions of compound gear units (ex: KA127R77) see page 565.

KAZ127..

33 051 00 11

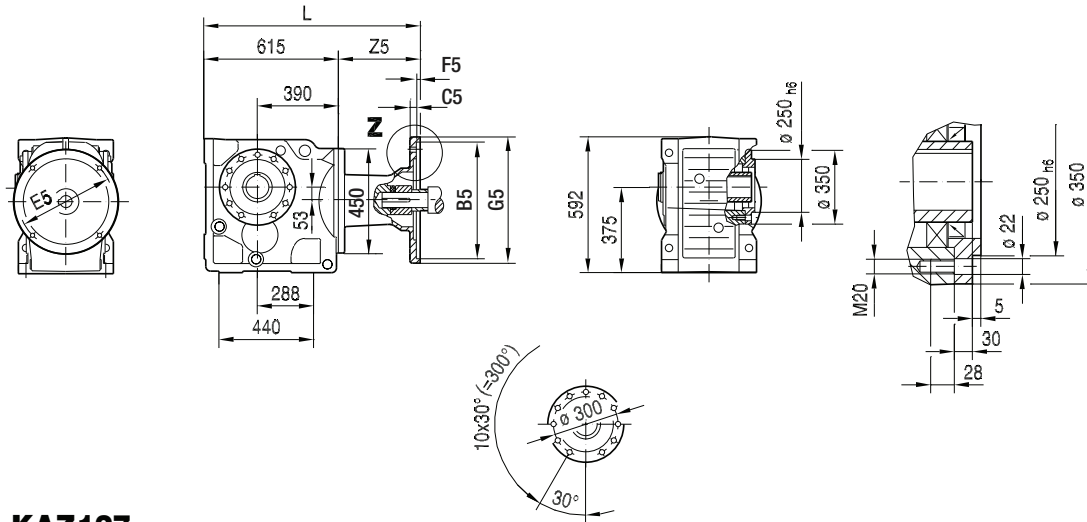

KAZ127..

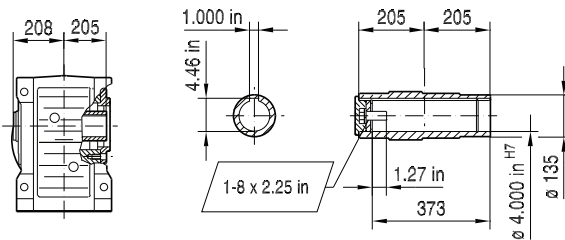

KHZ127..

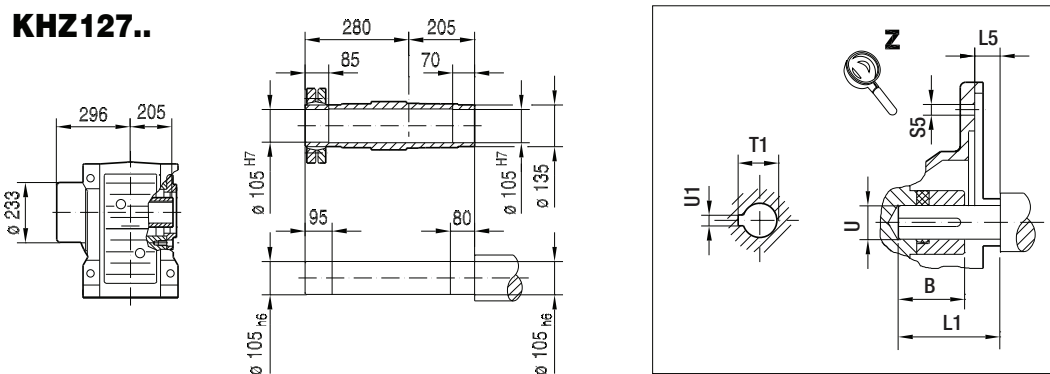

(→ 132)	B	B5	C5	E5	F5	G5	L	L1	L5	S5	T1	U	U1	Z5
AM213/215	2.76 in	8.50 in	11	7.25 in	5	228	773	3.38 in	0.25 in	15	1.52 in	1.375 in	0.312 in	157.5
AM254/256	3.65 in	8.50 in	12	7.25 in	5	228	823	4.00 in	0.25 in	15	1.80 in	1.625 in	0.375 in	208
AM284/286	4.00 in	10.50 in	15	9.00 in	5	286	830	4.62 in	0.25 in	15	2.10 in	1.875 in	0.500 in	215
AM324/326	3.88 in	12.50 in	17	11.0 in	5	356	890	5.25 in	0.25 in	17.5	2.36 in	2.125 in	0.500 in	275
AM364/365	4.51 in	12.50 in	17	11.0 in	5	356	890	5.88 in	0.25 in	17.5	2.66 in	2.375 in	0.625 in	275

Note: Dimensions in mm unless otherwise noted. For all available output shaft diameters, see page 575. For dimensions of compound gear units (ex: KAZ127R77) see page 565.

10 K - Helical Bevel

K.. AM.. [NEMA dimensions]

KT127..

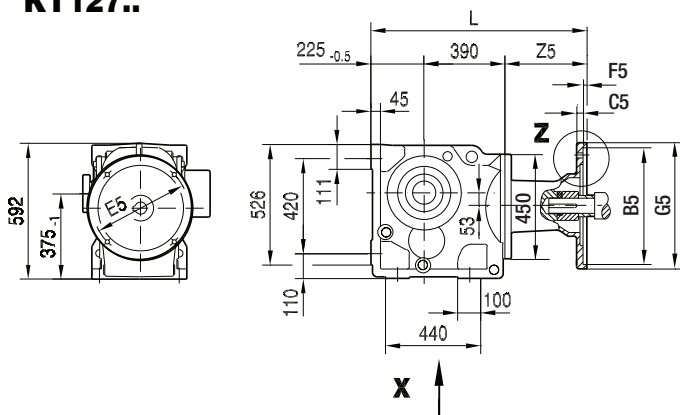

NON-Symmetrical

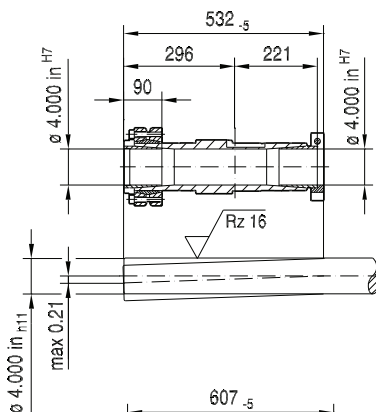
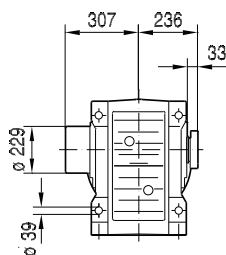

Symmetrical

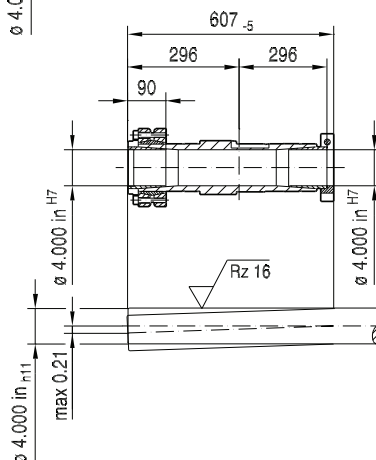
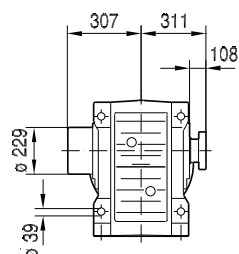

33 052 00 11

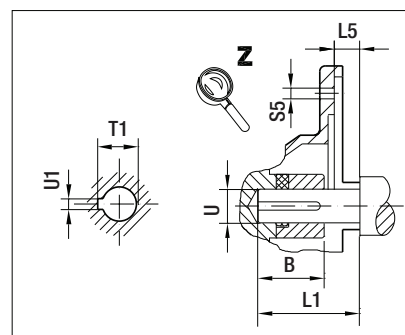
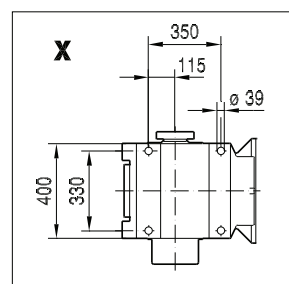
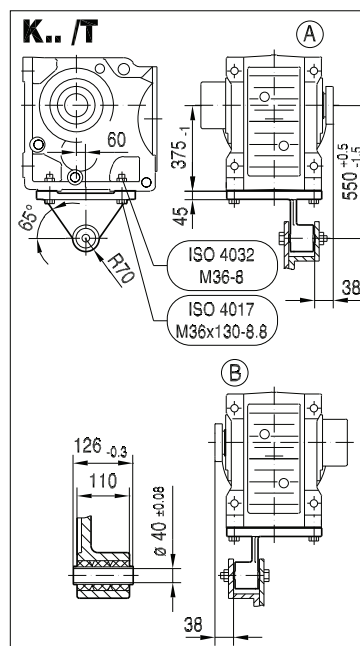

(→ 132)	B	B5	C5	E5	F5	G5	L	L1	L5	S5	T1	U	U1	Z5
AM213/215	2.76 in	8.50 in	11	7.25 in	5	228	773	3.38 in	0.25 in	15	1.52 in	1.375 in	0.312 in	157.5
AM254/256	3.65 in	8.50 in	12	7.25 in	5	228	823	4.00 in	0.25 in	15	1.80 in	1.625 in	0.375 in	208
AM284/286	4.00 in	10.50 in	15	9.00 in	5	286	830	4.62 in	0.25 in	15	2.10 in	1.875 in	0.500 in	215
AM324/326	3.88 in	12.50 in	17	11.0 in	5	356	890	5.25 in	0.25 in	17.5	2.36 in	2.125 in	0.500 in	275
AM364/365	4.51 in	12.50 in	17	11.0 in	5	356	890	5.88 in	0.25 in	17.5	2.66 in	2.375 in	0.625 in	275

Note: Dimensions in mm unless otherwise noted. For all available output shaft diameters, see page 577. For dimensions of compound gear units (ex: KT127R77) see page 565.

K157..

33 053 00 11

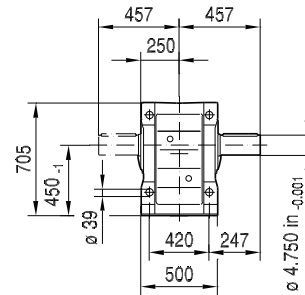
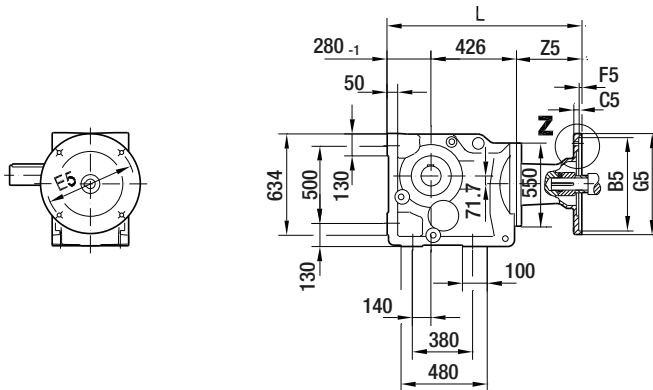

KA157B..

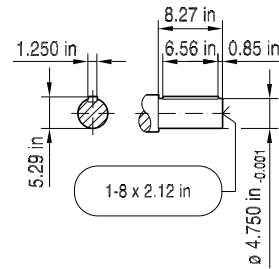
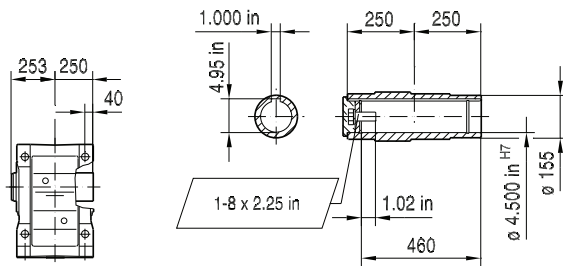

KH157B..

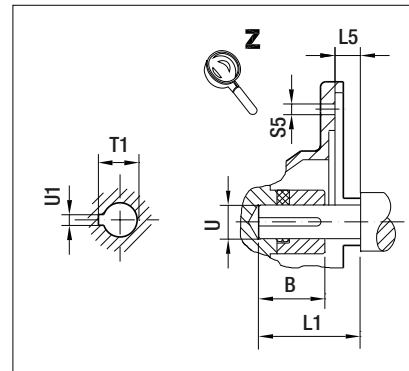
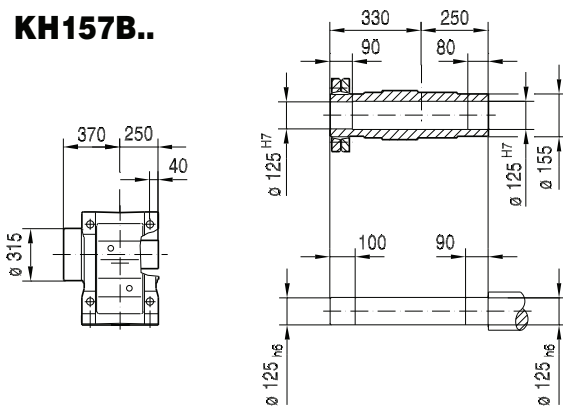

(→ 132)	B	B5	C5	E5	F5	G5	L	L1	L5	S5	T1	U	U1	Z5
AM254/256	3.65 in	8.50 in	12	7.25 in	5	228	906	4.00 in	0.25 in	15	1.80 in	1.625 in	0.375 in	200
AM284/286	4.00 in	10.50 in	15	9.00 in	5	286	913	4.62 in	0.25 in	15	2.10 in	1.875 in	0.500 in	207
AM324/326	3.88 in	12.50 in	17	11.0 in	5	356	973	5.25 in	0.25 in	17.5	2.36 in	2.125 in	0.500 in	267
AM364/365	4.51 in	12.50 in	17	11.0 in	5	356	973	5.88 in	0.25 in	17.5	2.66 in	2.375 in	0.625 in	267

Note: Dimensions in mm unless otherwise noted. For all available output shaft diameters, see page 573. For dimensions of compound gear units (ex: K157R97) see page 565.

10 K - Helical Bevel

K.. AM.. [NEMA dimensions]

KF157..

33 054 00 11

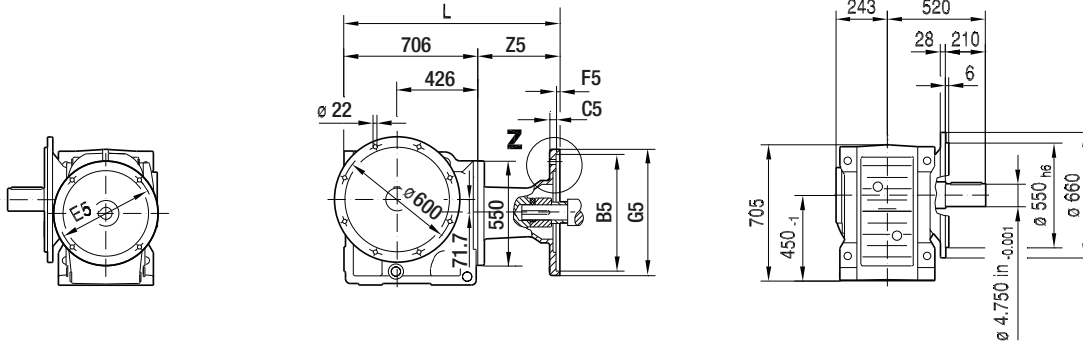

KAF157..

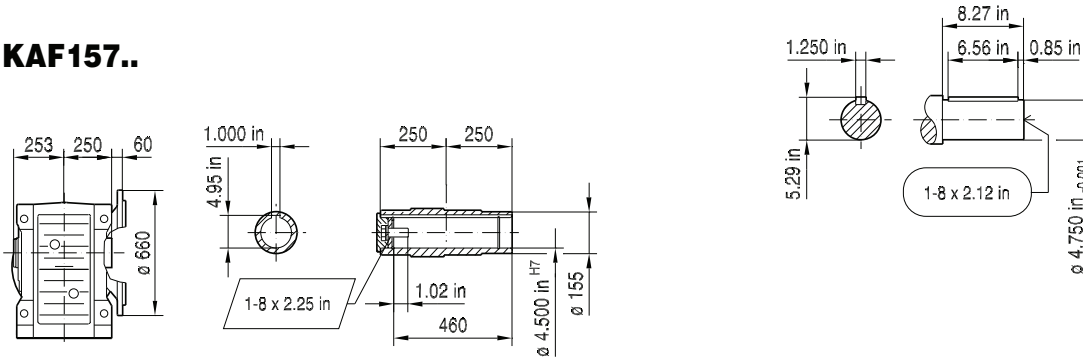

KHF157..

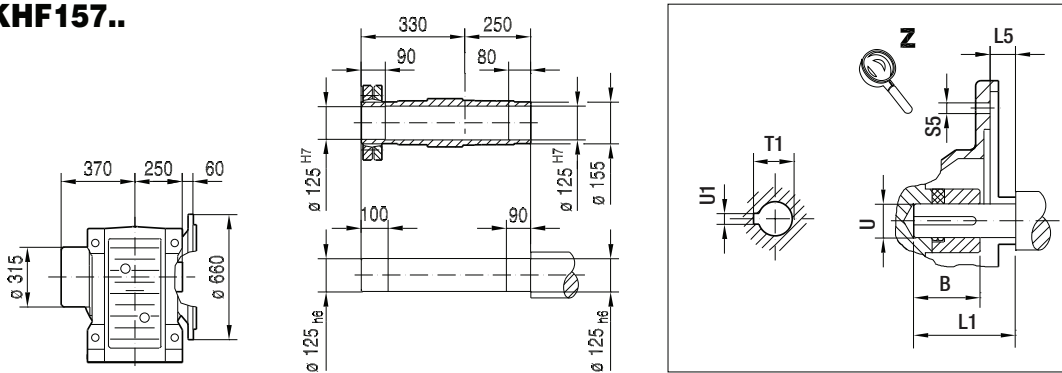

(→ 132)	B	B5	C5	E5	F5	G5	L	L1	L5	S5	T1	U	U1	Z5
AM254/256	3.65 in	8.50 in	12	7.25 in	5	228	906	4.00 in	0.25 in	15	1.80 in	1.625 in	0.375 in	200
AM284/286	4.00 in	10.50 in	15	9.00 in	5	286	913	4.62 in	0.25 in	15	2.10 in	1.875 in	0.500 in	207
AM324/326	3.88 in	12.50 in	17	11.0 in	5	356	973	5.25 in	0.25 in	17.5	2.36 in	2.125 in	0.500 in	267
AM364/365	4.51 in	12.50 in	17	11.0 in	5	356	973	5.88 in	0.25 in	17.5	2.66 in	2.375 in	0.625 in	267

Note: Dimensions in mm unless otherwise noted. For all available output shaft diameters, see page 573. For dimensions of compound gear units (ex: KF157R97) see page 565.

KA157..

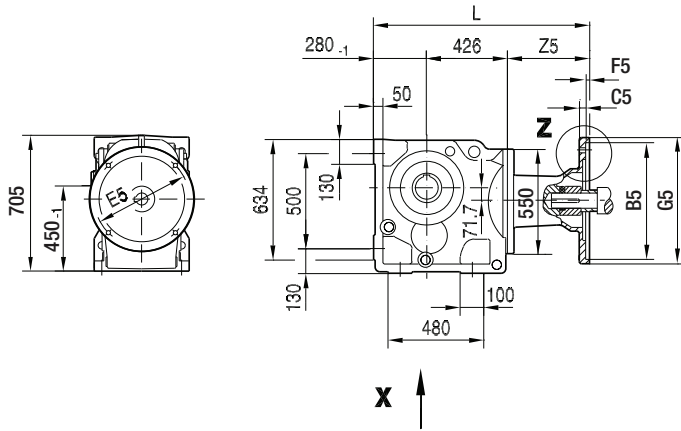

33 055 00 11

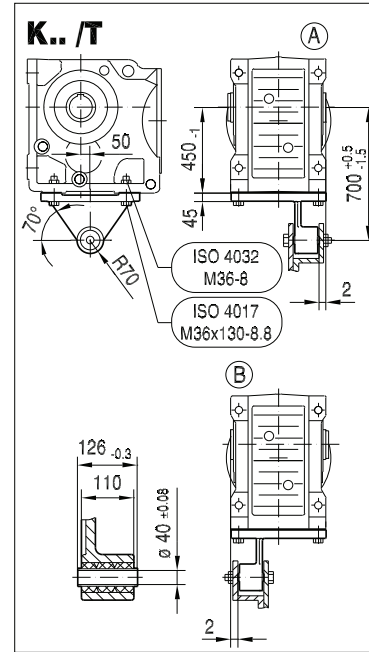

KA157..

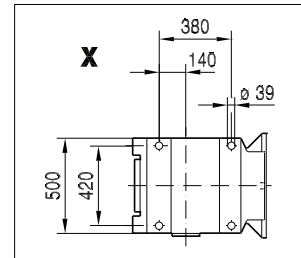
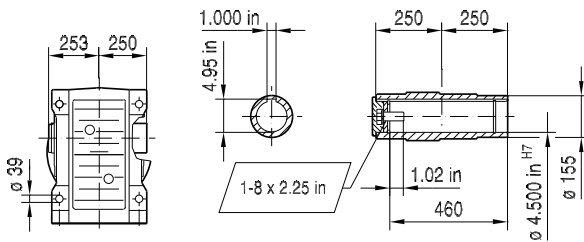

KH157..

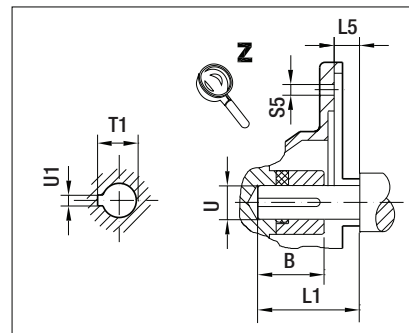
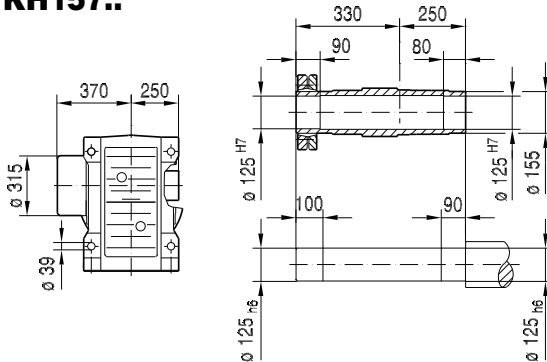

(→ 132)	B	B5	C5	E5	F5	G5	L	L1	L5	S5	T1	U	U1	Z5
AM254/256	3.65 in	8.50 in	12	7.25 in	5	228	906	4.00 in	0.25 in	15	1.80 in	1.625 in	0.375 in	200
AM284/286	4.00 in	10.50 in	15	9.00 in	5	286	913	4.62 in	0.25 in	15	2.10 in	1.875 in	0.500 in	207
AM324/326	3.88 in	12.50 in	17	11.0 in	5	356	973	5.25 in	0.25 in	17.5	2.36 in	2.125 in	0.500 in	267
AM364/365	4.51 in	12.50 in	17	11.0 in	5	356	973	5.88 in	0.25 in	17.5	2.66 in	2.375 in	0.625 in	267

Note: Dimensions in mm unless otherwise noted. For all available output shaft diameters, see page 575. For dimensions of compound gear units (ex: KA157R97) see page 565.

33 056 00 11

KAZ157..

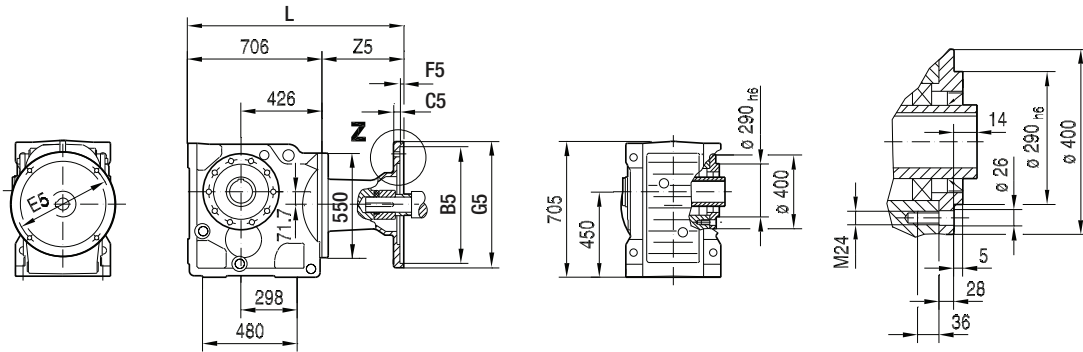

KAZ157..

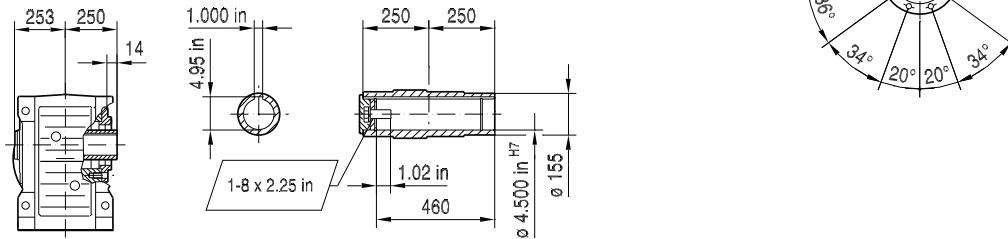

KHZ157..

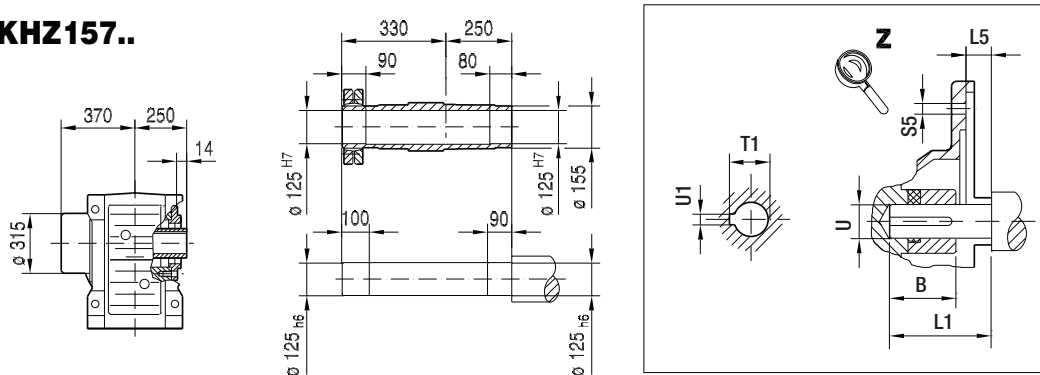

(→ 132)	B	B5	C5	E5	F5	G5	L	L1	L5	S5	T1	U	U1	Z5
AM254/256	3.65 in	8.50 in	12	7.25 in	5	228	906	4.00 in	0.25 in	15	1.80 in	1.625 in	0.375 in	200
AM284/286	4.00 in	10.50 in	15	9.00 in	5	286	913	4.62 in	0.25 in	15	2.10 in	1.875 in	0.500 in	207
AM324/326	3.88 in	12.50 in	17	11.0 in	5	356	973	5.25 in	0.25 in	17.5	2.36 in	2.125 in	0.500 in	267
AM364/365	4.51 in	12.50 in	17	11.0 in	5	356	973	5.88 in	0.25 in	17.5	2.66 in	2.375 in	0.625 in	267

Note: Dimensions in mm unless otherwise noted. For all available output shaft diameters, see page 575. For dimensions of compound gear units (ex: KAZ157R97) see page 565.

KT157..

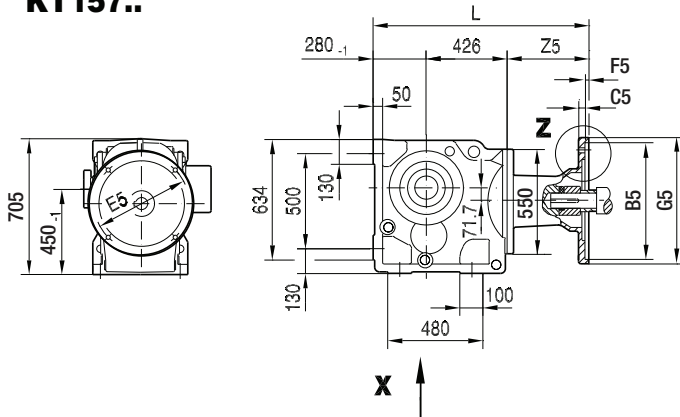

NON-Symmetrical

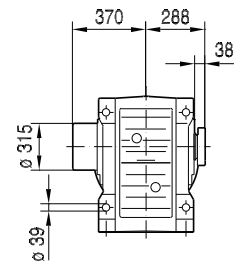

Symmetrical

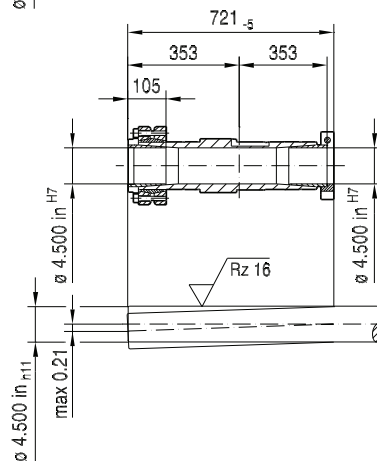
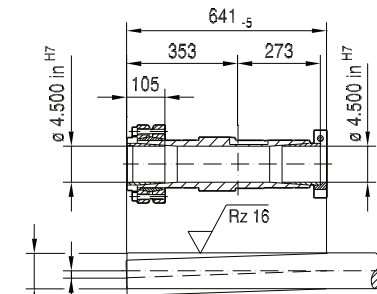
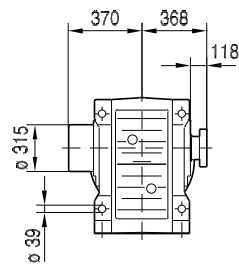

33 057 00 11

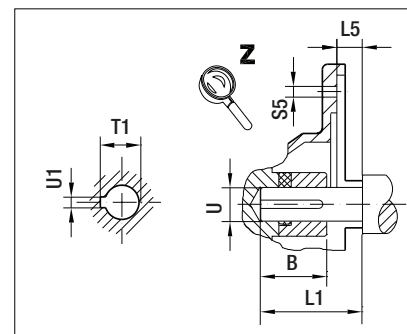
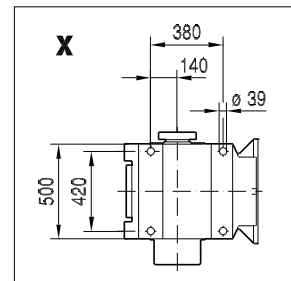
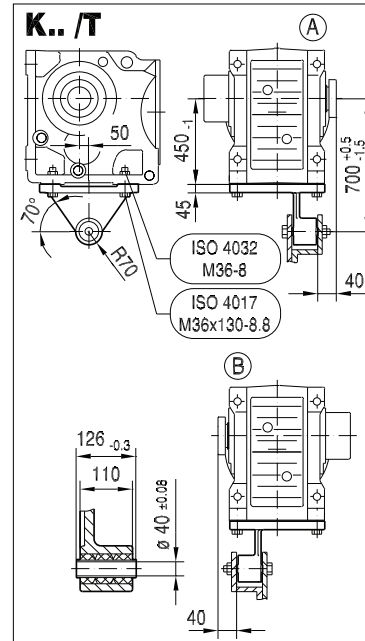

(→ 132)	B	B5	C5	E5	F5	G5	L	L1	L5	S5	T1	U	U1	Z5
AM254/256	3.65 in	8.50 in	12	7.25 in	5	228	906	4.00 in	0.25 in	15	1.80 in	1.625 in	0.375 in	200
AM284/286	4.00 in	10.50 in	15	9.00 in	5	286	913	4.62 in	0.25 in	15	2.10 in	1.875 in	0.500 in	207
AM324/326	3.88 in	12.50 in	17	11.0 in	5	356	973	5.25 in	0.25 in	17.5	2.36 in	2.125 in	0.500 in	267
AM364/365	4.51 in	12.50 in	17	11.0 in	5	356	973	5.88 in	0.25 in	17.5	2.66 in	2.375 in	0.625 in	267

Note: Dimensions in mm unless otherwise noted. For all available output shaft diameters, see page 577. For dimensions of compound gear units (ex: KT157R97) see page 565.

KH167..

33 059 00 11

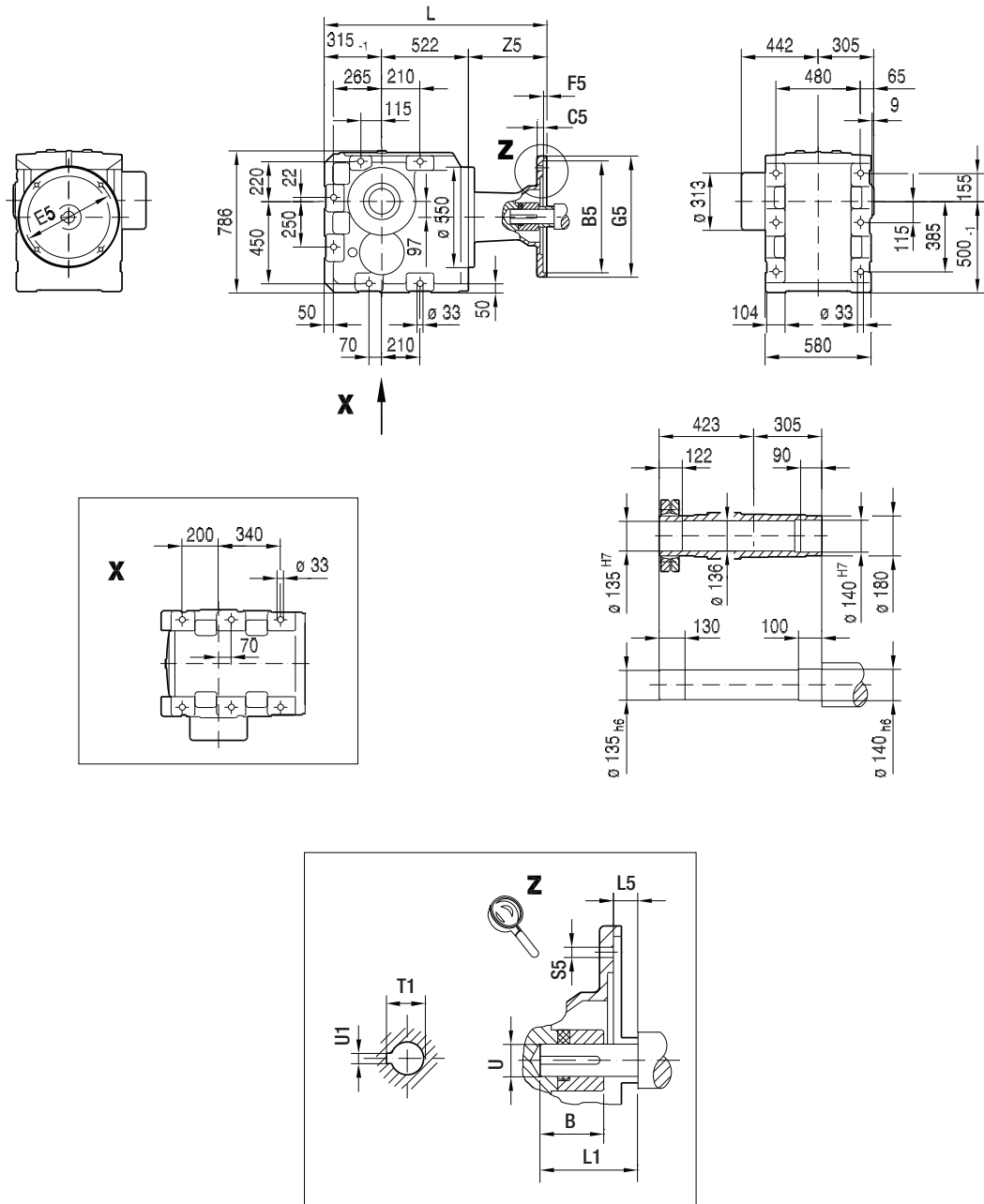

10

(→ 132)	B	B5	C5	E5	F5	G5	L	L1	L5	S5	T1	U	U1	Z5
AM254/256	3.65 in	8.50 in	12	7.25 in	5	228	1037	4.00 in	0.25 in	15	1.80 in	1.625 in	0.375 in	200
AM284/286	4.00 in	10.50 in	15	9.00 in	5	286	1044	4.62 in	0.25 in	15	2.10 in	1.875 in	0.500 in	207
AM324/326	3.88 in	12.50 in	17	11.0 in	5	356	1104	5.25 in	0.25 in	17.5	2.36 in	2.125 in	0.500 in	267
AM364/365	4.51 in	12.50 in	17	11.0 in	5	356	1104	5.88 in	0.25 in	17.5	2.66 in	2.375 in	0.625 in	267

Note: Dimensions in mm unless otherwise noted. For dimensions of compound gear units (ex: KH167R97) see page 565.

10 K - Helical Bevel

K.. AM.. [NEMA dimensions]

33 060 00 11

K187..

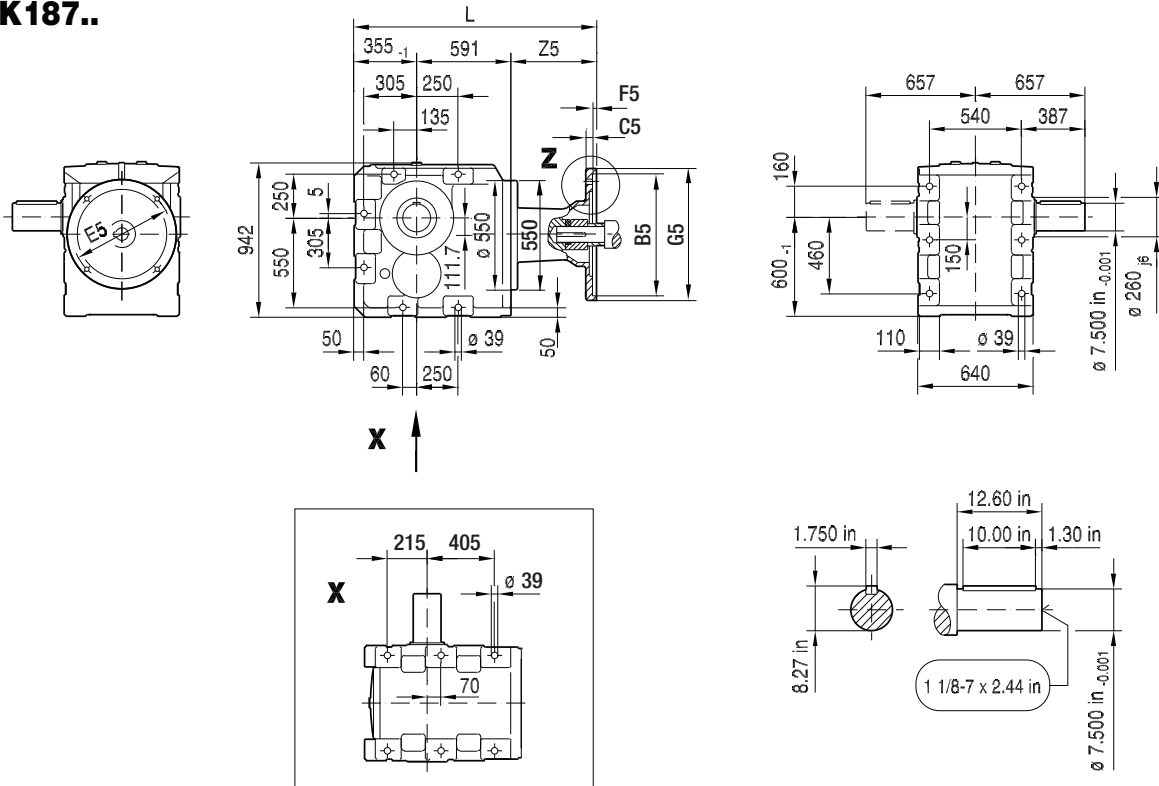

KH187B..

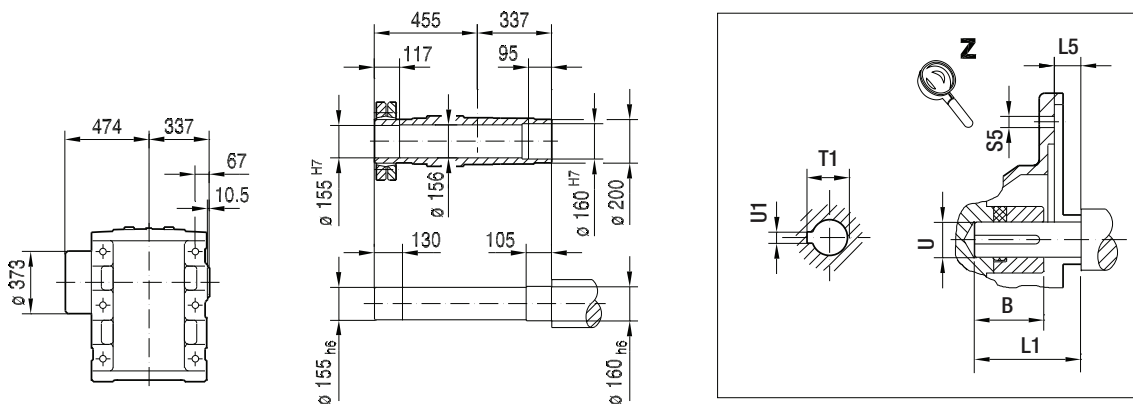

(→ 132)	B	B5	C5	E5	F5	G5	L	L1	L5	S5	T1	U	U1	Z5
AM254/256	3.65 in	8.50 in	12	7.25 in	5	228	1146	4.00 in	0.25 in	15	1.80 in	1.625 in	0.375 in	200
AM284/286	4.00 in	10.50 in	15	9.00 in	5	286	1153	4.62 in	0.25 in	15	2.10 in	1.875 in	0.500 in	207
AM324/326	3.88 in	12.50 in	17	11.0 in	5	356	1213	5.25 in	0.25 in	17.5	2.36 in	2.125 in	0.500 in	267
AM364/365	4.51 in	12.50 in	17	11.0 in	5	356	1213	5.88 in	0.25 in	17.5	2.66 in	2.375 in	0.625 in	267

Note: Dimensions in mm unless otherwise noted. For all available output shaft diameters, see page 574. For dimensions of compound gear units (ex: K187R97) see page 565.

KH187..

33 061 00 11

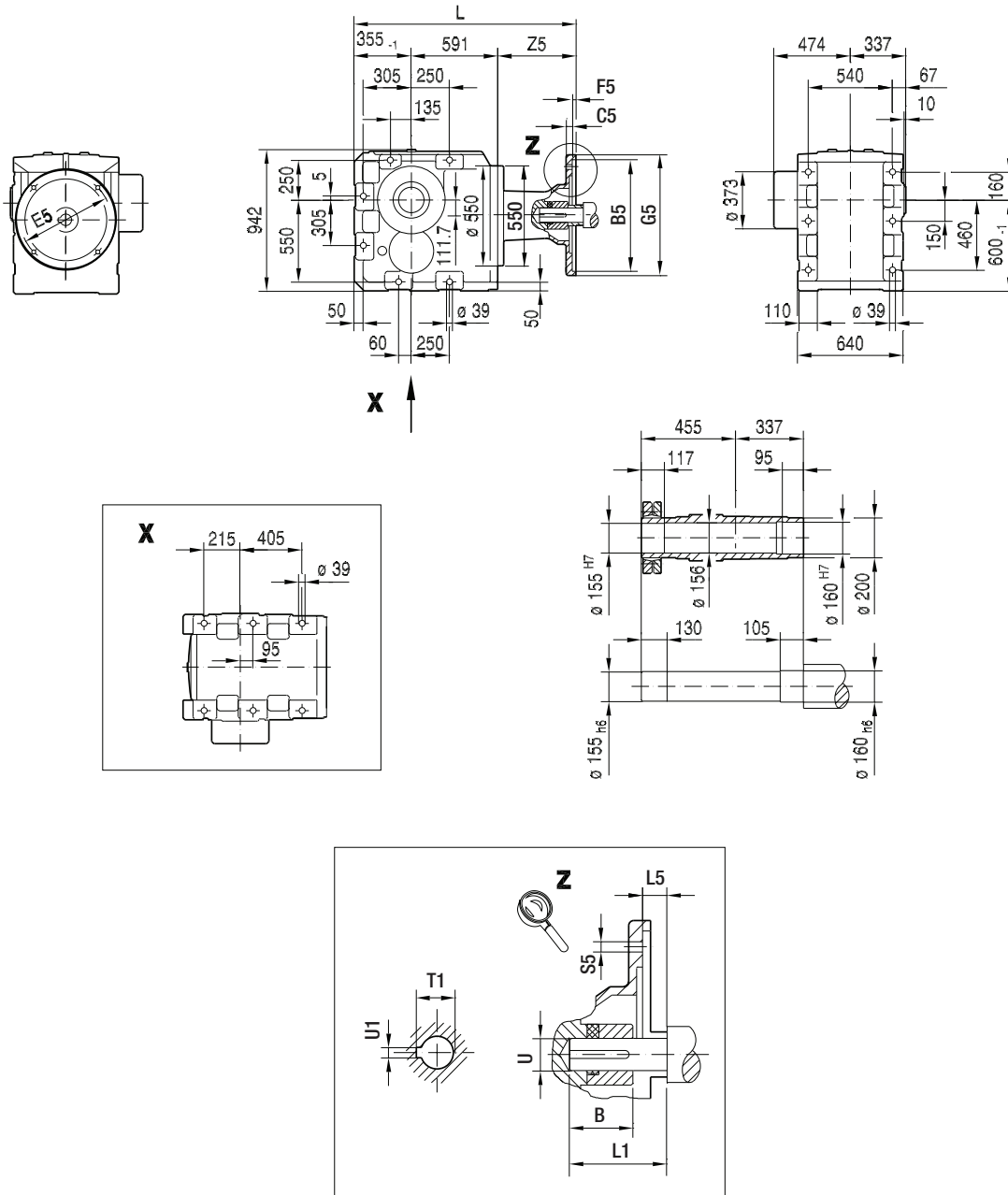

10

(→ 132)	B	B5	C5	E5	F5	G5	L	L1	L5	S5	T1	U	U1	Z5
AM254/256	3.65 in	8.50 in	12	7.25 in	5	228	1146	4.00 in	0.25 in	15	1.80 in	1.625 in	0.375 in	200
AM284/286	4.00 in	10.50 in	15	9.00 in	5	286	1153	4.62 in	0.25 in	15	2.10 in	1.875 in	0.500 in	207
AM324/326	3.88 in	12.50 in	17	11.0 in	5	356	1213	5.25 in	0.25 in	17.5	2.36 in	2.125 in	0.500 in	267
AM364/365	4.51 in	12.50 in	17	11.0 in	5	356	1213	5.88 in	0.25 in	17.5	2.66 in	2.375 in	0.625 in	267

Note: Dimensions in mm unless otherwise noted. For dimensions of compound gear units (ex: KH187R97) see page 565.

10.4 K.. AM.. [IEC dimensions]

23 002 100

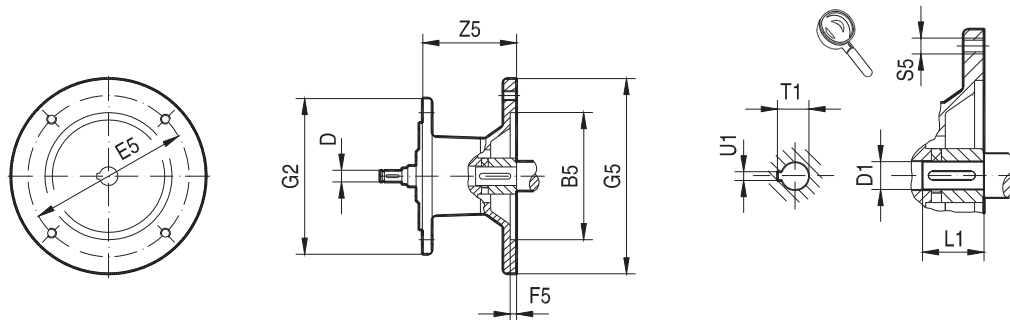

		Dimensions in mm											
		B5	D	E5	F5	G2	G5	S5	Z5	D1	L1	T1	U1
K..19 K..29 K..37	AM63	95	10	115	3.5	120	140	M8	72	11	23	12.8	4
	AM71 ¹⁾	110		130	4		14			30	16.3	5	
	AM80 ¹⁾	130	12	165	4.5		200	M10	106	19	40	21.8	6
	AM90 ¹⁾		14							24	50	27.3	8
K..47 K..57 K..67	AM63	95	10	115	3.5	160	140	M8	66	11	23	12.8	4
	AM71	110		130	4		14			30	16.3	5	
	AM80	130	12	165	4.5		200	M10	99	19	40	21.8	6
	AM90		14							24	50	27.3	8
	AM100 ¹⁾	180	16	215	5		250	M12	134	28	60	31.3	8
	AM112 ¹⁾		18							300	191	38	80
	AM132S/M ¹⁾	230	22	265									
		230	28	265									
K..77	AM63	95	10	115	3.5	200	140	M8	60	11	23	12.8	4
	AM71	110		130	4		14			30	16.3	5	
	AM80	130	12	165	4.5		200	M10	92	19	40	21.8	6
	AM90		14							24	50	27.3	8
	AM100 ¹⁾	180	16	215	5		250	M12	126	28	60	31.3	8
	AM112 ¹⁾		18							300	179	38	80
	AM132S/M ¹⁾	230	22	265									
AM132ML ¹⁾		230	28	265									
K..87	AM80	130	12	165	4.5	250	200	M10	87	19	40	21.8	6
	AM90		14							24	50	27.3	8
	AM100	180	16	215	5		250	M12	121	28	60	31.3	8
	AM112		18							300	174	38	80
	AM132S/M	230	22	265	5		250	M12	174	38	80	41.3	10
	AM132ML		28							350	232	42	110
	AM160 ¹⁾	250	28	300	6		250	M16	232	48	110	51.8	14
AM180 ¹⁾	32												

1) Check dimension (G5)/2 because adapter may protrude past the bottom of the feet on a foot-mounted gear unit.

23 003 100

Fig.1

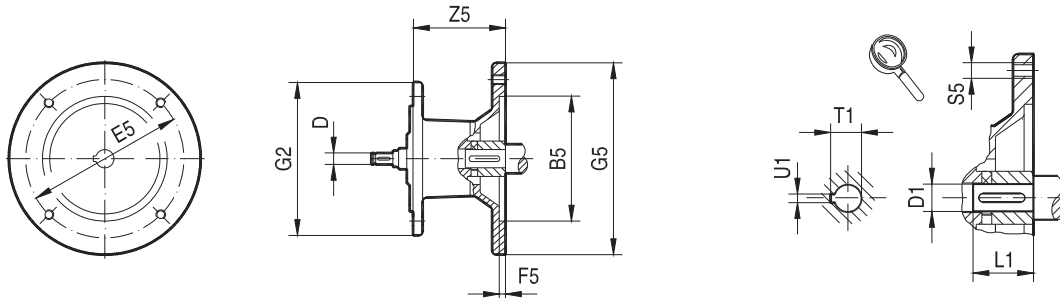

Fig.2

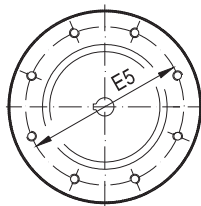

		Fig.	Dimensions in mm											
			B5	D	E5	F5	G2	G5	S5	Z5	D1	L1	T1	U1
K..97	AM100	1	180	16	215	5	300	250	M12	116	28	60	31.3	8
	AM112			18										
	AM132S/M		230	22	265	6		350	M16	227	42	110	45.3	12
	AM132ML			28							48		51.8	
	AM160		250	28	300	7		400	M16	268	55	110	59.3	16
	AM180			32							55		59.3	
	AM200		300	38	350	7		400	400	55	59.3	16		
K..107	AM100	1	180	16	215	5	350	250	M12	110	28	60	31.3	8
	AM112			18										
	AM132S/M		230	22	265	6		350	M16	221	42	110	45.3	12
	AM132ML			28							48		51.8	
	AM160		250	28	300	7		400	M16	262	55	110	59.3	16
	AM180			32							55		59.3	
	AM200		300	38	350	7		450	M16	277	60	140	64.4	18
	AM225	350		38			400				450		277	

23 004 100

Fig.1

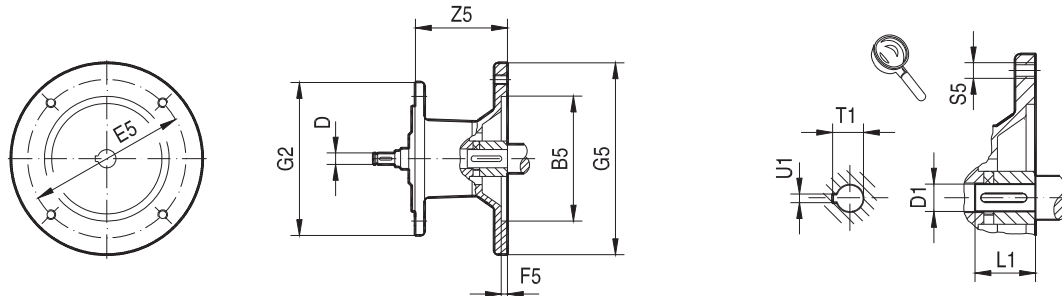

Fig.2

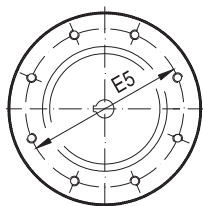
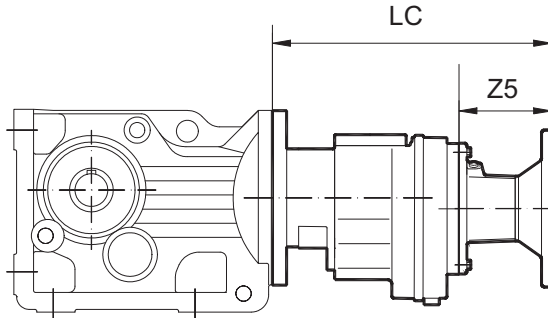

		Fig.	Dimensions in mm											
			B5	D	E5	F5	G2	G5	S5	Z5	D1	L1	T1	U1
K..127	AM132S/M	1	230	22	265	5	450	300	M12	148	38	80	41.3	10
	AM132ML			28							38			
	AM160		250	28	300	6		350	206	42	110	45.3	12	
	AM180	32		48				51.8						
	AM200	2	300	38	350	7		400	247	55	140	59.3	16	
	AM225							350				60		64.4
	AM250	450	48	500	500	550		336	65	75	140	69.4	18	
AM280	75						79.9					20		
K..157 K..167 K..187	AM160	1	250	28	300	6	550	350	M16	198	42	110	45.3	12
	AM180			32							48			
	AM200		300	38	350	7		400		55	59.3	16		
	AM225	350	38	400	450			60		64.4				
	AM250	2	450	48	500	500		550		328	65	140	69.4	18
	AM280												75	

10.5 K.. R.. AM.. [compound NEMA dimensions]



K_R_AM

Large Unit	Small Unit	Adapter	Z5	LC
K..47 K..57 K..67	R37	AM56	93.5	258.5
		AM143	117	282
		AM145	117	282
K..77	R37	AM56	93.5	250.5
		AM143	117	274
		AM145	117	274
K..87	R57	AM56	87	303
		AM143	110.5	326.5
		AM145	110.5	326.5
		AM182	147.5	363.5
		AM184	147.5	363.5
		AM213/215	200.5	416.5
K..97	R57	AM56	87	298
		AM143	110.5	321.5
		AM145	110.5	321.5
		AM182	147.5	358.5
		AM184	147.5	358.5
K..107	R77	AM56	81	328
		AM143	103.5	350.5
		AM145	103.5	350.5
		AM182	139.5	386.5
		AM184	139.5	386.5
		AM213/215	188.5	435.5

Large Unit	Small Unit	Adapter	Z5	LC
K..127	R77	AM56	81	313
		AM143	103.5	335.5
		AM145	103.5	335.5
		AM182	139.5	371.5
		AM184	139.5	371.5
	AM213/215	188.5	420.5	
	R87	AM143	98.5	378.5
		AM145	98.5	378.5
		AM182	134.5	414.5
		AM184	134.5	414.5
AM213/215		183.5	463.5	
AM254/256	234	514		
AM284/286	241	521		
K..157 K..167 K..187	R97	AM182	129.5	454.5
		AM184	129.5	454.5
		AM213/215	178.5	503.5
		AM254/256	229	554
		AM284/286	236	561
		AM324/326	296	621
	R107	AM364/365	296	621
		AM182	123.5	505.5
		AM184	123.5	505.5
		AM213/215	172.5	554.5
		AM254/256	223	605
		AM284/286	230	612
		AM324/326	290	672
AM364/365	290	672		

10.6 K.. AD.. [dimensions]

10.6.1 Input Shaft - Inch

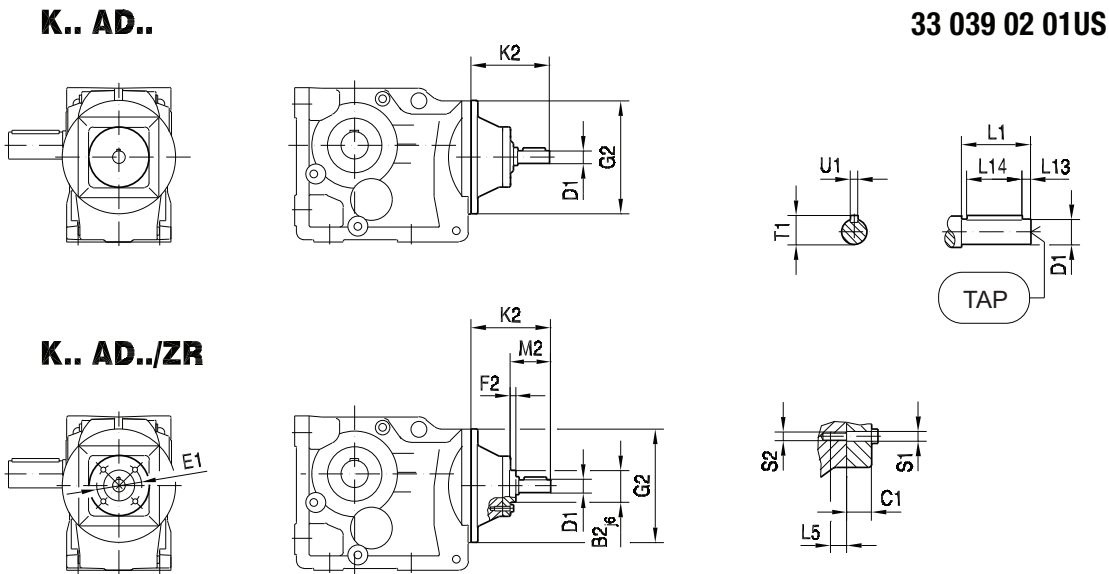

		B2	C1	D1	E1	F2	G2	K2	L1	L5	L13	L14	M2	S1	S2	T1	U1	TAP (inch)
K..19	AD1	-	-	0.625 in	-	-	120	102	40	-	4	32	-	-	-	0.70 in	0.1875 in	1/4-20 x0.63
K..29	AD2	55	13.5	0.750 in	80	8		130	40	12	4	32	50	9	M8	0.83 in		
K..37	AD3	70	15.5	0.875 in	105	8	160	123	40	12	4	32	50	9	M8	0.83 in	0.1875 in	1/4-20 x0.63
K..39	AD2	55	13.5	0.750 in	80	8		159	50	16	5	40	60	11	M10	0.96 in		
K..47	AD3	70	15.5	0.875 in	105	8	200	116	40	12	4	32	50	9	M8	0.83 in	0.1875 in	5/16-18 x0.63
K..49	AD2	55	13.5	0.750 in	80	8		151	50	16	5	40	60	11	M10	0.96 in		
K..49	AD3	70	15.5	0.875 in	105	8		224	80	20	5	70	95.5	13.5	M12	1.51 in	0.3125 in	1/2-13 x1.12
K..49	AD4	100	16	1.375 in	130	13		224	80	20	5	70	95.5	13.5	M12	1.51 in	0.3125 in	1/2-13 x1.12
K..57	AD2	55	13.5	0.750 in	80	8	160	123	40	12	4	32	50	9	M8	0.83 in	0.1875 in	1/4-20 x0.63
K..67	AD3	70	15.5	0.875 in	105	8		159	50	16	5	40	60	11	M10	0.96 in		
K..77	AD2	55	13.5	0.750 in	80	8	200	116	40	12	4	32	50	9	M8	0.83 in	0.1875 in	1/4-20 x0.63
K..77	AD3	70	15.5	0.875 in	105	8		151	50	16	5	40	60	11	M10	0.96 in		
K..77	AD4	100	16	1.375 in	130	13		224	80	20	5	70	95.5	13.5	M12	1.51 in	0.3125 in	1/2-13 x1.12
K..87	AD2	55	13.5	0.750 in	80	8		250	111	40	12	4	32	50	9	M8	0.83 in	0.1875 in
K..87	AD3	70	15.5	0.875 in	105	8	156		60	16	5	50	70	11	M10	0.96 in	5/16-18 x0.87	
K..87	AD4	100	16	1.375 in	130	13	219		80	20	5	70	95.5	13.5	M12	1.51 in	0.3125 in	1/2-13 x1.12
K..87	AD5	120	24	1.625 in	180	11	292		110	20	10	70	126	13.5	M12	1.79 in	0.375 in	5/8-11 x1.38
K..97	AD3	70	15.5	0.875 in	105	8	300	151	60	16	5	50	70	11	M10	0.96 in	0.1875 in	5/16-18 x0.87
K..97	AD4	100	16	1.375 in	130	13		214	80	20	5	70	95.5	13.5	M12	1.51 in		
K..97	AD5	120	24	1.625 in	180	11		287	110	20	10	70	126	13.5	M12	1.79 in	0.375 in	5/8-11 x1.38
K..97	AD6	130	22.5	1.875 in	200	11		327	110	26	10	80	130.5	17.5	M16	2.09 in	0.50 in	5/8-11 x1.38
K..107	AD3	70	15.5	0.875 in	105	8	350	145	60	16	5	50	70	11	M10	0.96 in	0.1875 in	5/16-18 x0.87
K..107	AD4	100	16	1.375 in	130	13		208	80	20	5	70	95.5	13.5	M12	1.51 in		
K..107	AD5	120	24	1.625 in	180	11		281	110	20	10	70	126	13.5	M12	1.79 in	0.375 in	5/8-11 x1.38
K..107	AD6	130	22.5	1.875 in	200	11		321	110	26	10	80	130.5	17.5	M16	2.09 in	0.50 in	5/8-11 x1.38
K..127	AD4	100	16	1.375 in	130	13	450	193	80	20	5	70	95.5	13.5	M12	1.51 in	0.3125 in	1/2-13 x1.12
K..127	AD5	120	24	1.625 in	180	11		266	110	20	10	70	126	13.5	M12	1.79 in		
K..127	AD6	130	22.5	1.875 in	200	11		306	110	26	10	80	130.5	17.5	M16	2.09 in	0.50 in	5/8-11 x1.38
K..127	AD7	125	19	2.125 in	190	13		300	110	30	10	90	133	22	M20	2.35 in	0.50 in	3/4-10 x1.61
K..127	AD8	120	22.5	2.750 in	210	5	383	140	19.5	15	110	155	13.5	M12	3.03 in	0.625 in	3/4-10 x1.61	
K..157	AD5	120	24	1.625 in	180	11	550	258	110	20	10	70	126	13.5	M12	1.79 in	0.375 in	5/8-11 x1.38
K..167	AD6	130	22.5	1.875 in	200	11		298	110	26	10	80	130.5	17.5	M16	2.09 in		
K..187	AD7	125	19	2.125 in	190	13		292	110	30	10	90	133	22	M20	2.35 in	0.50 in	3/4-10 x1.61
K..187	AD8	120	22.5	2.750 in	210	5		374	140	19.5	15	110	155	13.5	M12	3.03 in	0.625 in	3/4-10 x1.61

10.6.2 Input shaft - Metric

K.. AD..

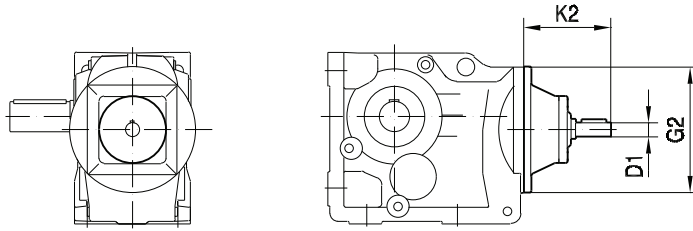

33 039 02 01

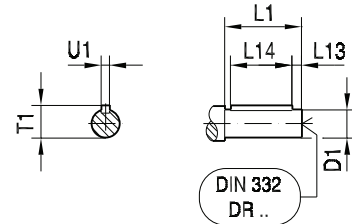

K.. AD../ZR

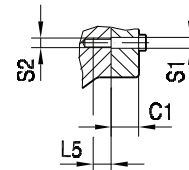
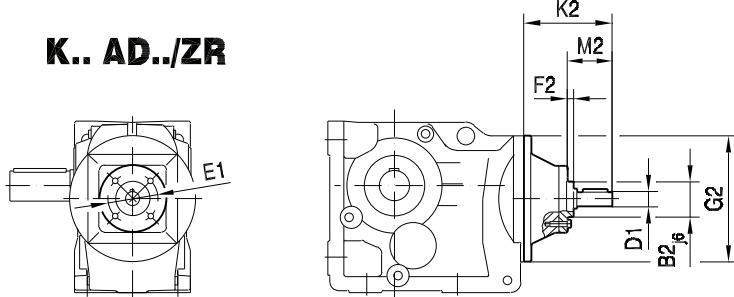

		B2	C1	E1	F2	G2	K2	L5	M2	S1	S2	D1	L1	L13	L14	T1	U1
K..19	AD1	-	-	-	-	120	102	-	-	-	-	16	40	4	32	18	5
K..29																	
K..37	AD2, AD2/ZR	55	13.5	80	8	120	130	12	50	9	M8	19	40	4	32	21.5	6
K..39	AD2, AD2/ZR	55	13.5	80	8	160	123	12	50	9	M8	19	40	4	32	21.5	6
K..47	AD3, AD3/ZR	70	15.5	105	8	160	159	16	60	11	M10	24	50	5	40	27	8
	AD2, AD2/ZR	55	13.5	80	8	200	116	12	50	9	M8	19	40	4	32	21.5	6
K..49	AD3, AD3/ZR	70	15.5	105	8	200	151	16	60	11	M10	24	50	5	40	27	8
	AD4, AD4/ZR	100	16	130	13	200	224	20	95.5	13.5	M12	38	80	5	70	41	10
K..57	AD2, AD2/ZR	55	13.5	80	8	160	123	12	50	9	M8	19	40	4	32	21.5	6
K..67	AD3, AD3/ZR	70	15.5	105	8	160	159	16	60	11	M10	24	50	5	40	27	8
	AD2, AD2/ZR	55	13.5	80	8	200	116	12	50	9	M8	19	40	4	32	21.5	6
K..77	AD3, AD3/ZR	70	15.5	105	8	200	151	16	60	11	M10	24	50	5	40	27	8
	AD4, AD4/ZR	100	16	130	13	200	224	20	95.5	13.5	M12	38	80	5	70	41	10
	AD2, AD2/ZR	55	13.5	80	8	250	111	12	50	9	M8	19	40	4	32	21.5	6
K..87	AD3, AD3/ZR	70	15.5	105	8	250	156	16	70	11	M10	28	60	5	50	31	8
	AD4, AD4/ZR	100	16	130	13	250	219	20	95.5	13.5	M12	38	80	5	70	41	10
	AD5, AD5/ZR	120	24	180	11	250	292	20	126	13.5	M12	42	110	10	70	45	12
	AD3, AD3/ZR	70	15.5	105	8	300	151	16	70	11	M10	28	60	5	50	31	8
K..97	AD4, AD4/ZR	100	16	130	13	300	214	20	95.5	13.5	M12	38	80	5	70	41	10
	AD5, AD5/ZR	120	24	180	11	300	287	20	126	13.5	M12	42	110	10	70	45	12
	AD6, AD6/ZR	130	22.5	200	11	300	327	26	130.5	17.5	M16	48	110	10	80	51.5	14
	AD3, AD3/ZR	70	15.5	105	8	350	145	16	70	11	M10	28	60	5	50	31	8
K..107	AD4, AD4/ZR	100	16	130	13	350	208	20	95.5	13.5	M12	38	80	5	70	41	10
	AD5, AD5/ZR	120	24	180	11	350	281	20	126	13.5	M12	42	110	10	70	45	12
	AD6, AD6/ZR	130	22.5	200	11	350	321	26	130.5	17.5	M16	48	110	10	80	51.5	14
	AD4, AD4/ZR	100	16	130	13	450	193	20	95.5	13.5	M12	38	80	5	70	41	10
K..127	AD5, AD5/ZR	120	24	180	11	450	266	20	126	13.5	M12	42	110	10	70	45	12
	AD6, AD6/ZR	130	22.5	200	11	450	306	26	130.5	17.5	M16	48	110	10	80	51.5	14
	AD7, AD7/ZR	125	19	190	13	450	300	30	133	22	M20	55	110	10	90	59	16
	AD8, AD8/ZR	120	22.5	210	5	450	383	19.5	155	13.5	M12	70	140	15	110	74.5	20
K..157	AD5, AD5/ZR	120	24	180	11	550	258	20	126	13.5	M12	42	110	10	70	45	12
K..167	AD6, AD6/ZR	130	22.5	200	11	550	298	26	130.5	17.5	M16	48	110	10	80	51.5	14
K..187	AD7, AD7/ZR	125	19	190	13	550	292	30	133	22	M20	55	110	10	90	59	16
	AD8, AD8/ZR	120	22.5	210	5	550	374	19.5	155	13.5	M12	70	140	15	110	74.5	20

10.7 K.. R.. AD.. [compound dimensions]

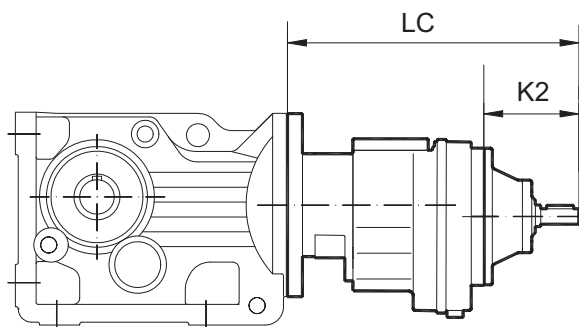

K_R_AD

Large Unit	Small Unit	Adapter	K2	LC
K..47 K..57 K..67	R37	AD1	102	267
		AD2	130	295
	K..49 K..77	R37	AD1	102
		AD2	130	287
K..87	R57	AD2	123	339
		AD3	159	375
K..97	R57	AD2	123	334
		AD3	159	370
K..107	R77	AD2	116	363
		AD3	151	398
		AD4	224	471
K..127	R77	AD2	116	348
		AD3	151	383
		AD4	224	456
	R87	AD2	111	391
		AD3	156	436
		AD4	219	499
K..157 K..167 K..187	R97	AD5	292	572
		AD3	151	476
		AD4	214	539
		AD5	287	612
	R107	AD6	327	652
		AD3	145	527
		AD4	208	590
		AD5	281	663
		AD6	321	703

10.8 K.. AD../P [dimensions]

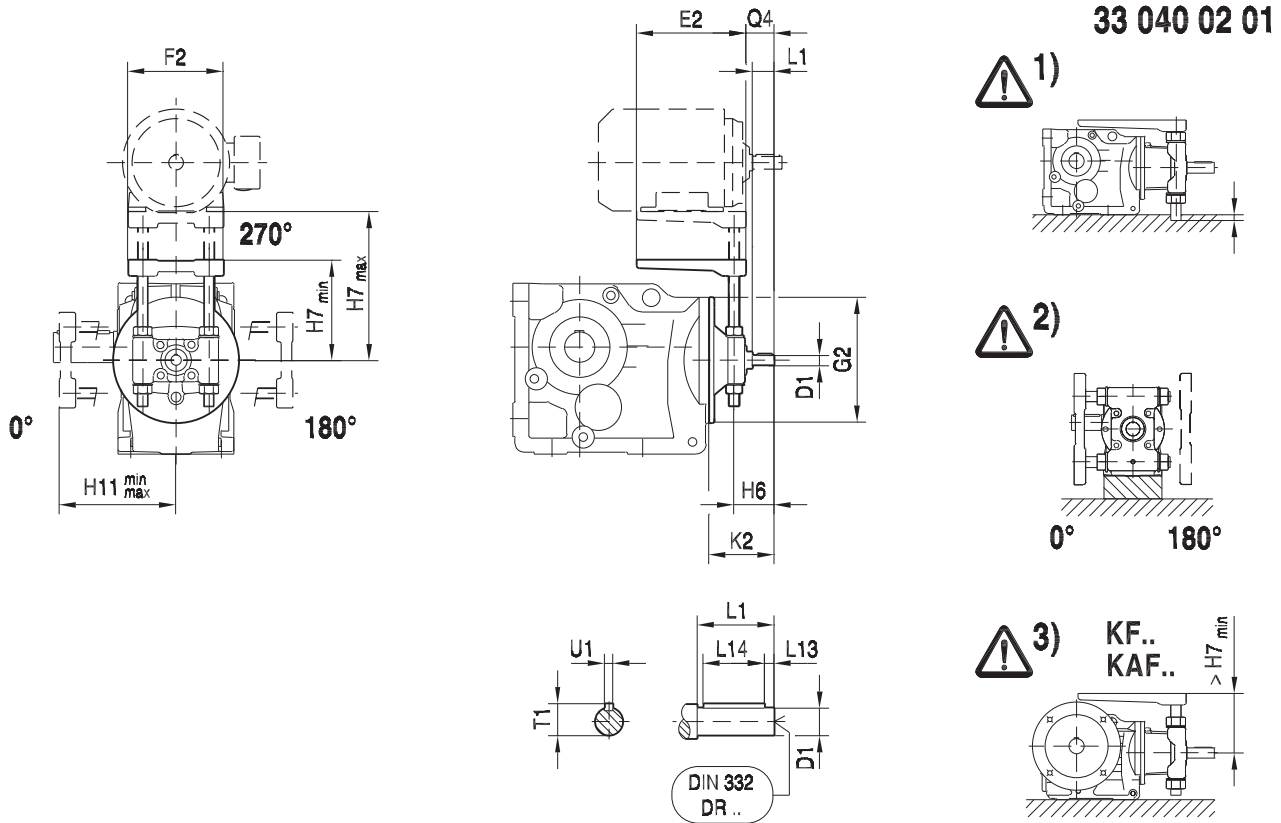

		E2	F2	G2	H6	H7 min	H7 max	H11min in	H11max ax	K2	Q4	D1	L1	L13	L14	T1	U1	⚠ ₁₃₁
K..37	AD2/P	195	180	120	65	100	165	95	165	130	43	19	40	4	32	21.5	6	1)
K..47	AD2/P	195	180	160	65	110	165	110	165	123	43	19	40	4	32	21.5	6	1)
	AD3/P	230	240		80	125	175	125	175	159	54	24	50	5	40	27	8	1), 2)
K..57	AD2/P	195	180	160	65	120	165	120	165	123	43	19	40	4	32	21.5	6	1), 2), 3)
	AD3/P	230	240		80	130	175	130	175	159	54	24	50	5	40	27	8	
K..67	AD2/P	195	180	160	65	130	200	125	165	123	43	19	40	4	32	21.5	6	1)
	AD3/P	230	240		80	135	175	130	175	159	54	24	50	5	40	27	8	3)
K..77	AD2/P	195	180	200	65	160	260	140	260	116	43	19	40	4	32	21.5	6	1)
	AD3/P	230	240		80	160	230	145	175	151	54	24	50	5	40	27	8	1)
	AD4/P	345	291		118	170	210	150	210	224	83	38	80	5	70	41	10	3)
K..87	AD2/P	195	180	250	65	180	260	170	200	111	43	19	40	4	32	21.5	6	1)
	AD3/P	230	240		90	180	230	175	230	156	64	28	60	5	50	31	8	
	AD4/P	345	291		118	190	280	180	210	219	83	38	80	5	70	41	10	
	AD5/P	430	355		153	190	250	185	250	292	113	42	110	10	70	45	12	
K..97	AD3/P	230	240	300	90	210	320	210	320	151	64	28	60	5	50	31	8	1), 3)
	AD4/P	345	291		118	215	280	215	280	214	83	38	80	5	70	41	10	
	AD5/P	430	355		153	225	325	215	250	287	113	42	110	10	70	45	12	
K..107	AD3/P	230	240	350	90	260	320	220	320	145	64	28	60	5	50	31	8	3)
	AD4/P	345	291		118	265	360	220	280	208	83	38	80	5	70	41	10	
	AD5/P	430	355		153	270	325	225	325	281	113	42	110	10	70	45	12	
	AD6/P	495	457		163	270	310	250	310	321	114	48	110	10	80	51.5	14	
K..127	AD4/P	345	291	450	118	305	360	245	280	193	83	38	80	5	70	41	10	3)
	AD5/P	430	355		153	310	405	255	325	266	113	42	110	10	70	45	12	
	AD6/P	495	457		163	305	360	300	360	306	114	48	110	10	80	51.5	14	
	AD7/P	650	570		170	305	365	305	365	300	112	55	110	10	90	59	16	

10 K - Helical Bevel

K.. AD../P [dimensions]

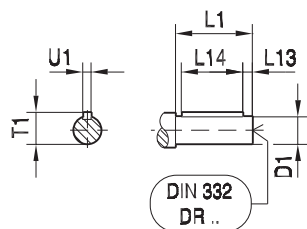
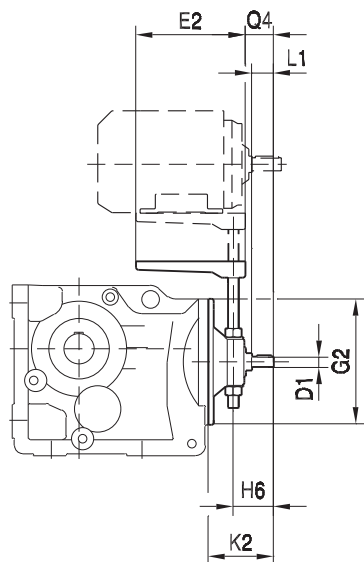
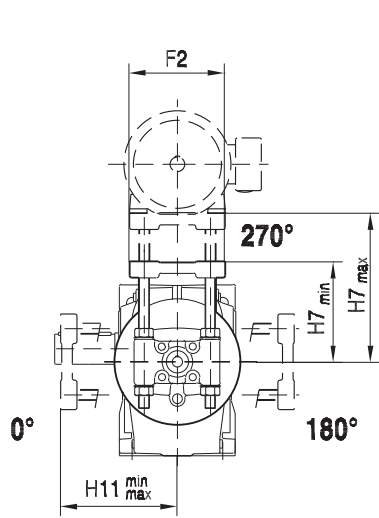

33 042 02 01

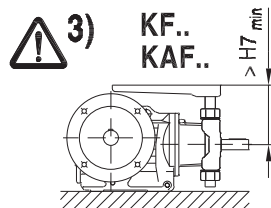
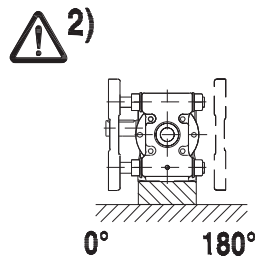
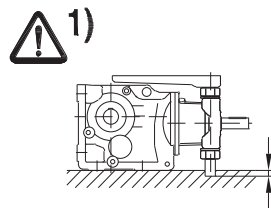

		E2	F2	G2	H6	H7 min	H7 max	H11 min	H11 max	K2	Q4	D1	L1	L13	L14	T1	U1	⚠
K..157	AD5/P	430	355	550	153	360	405	295	325	258	113	42	110	10	70	45	12	→131
	AD6/P	495	457		163	375	475	375	475	298	114	48	110	10	80	51.5	14	3)
	AD7/P	650	570		170	375	475	375	475	292	112	55	110	10	90	59	16	3)
K..167	AD5/P	430	355	550	153	415	495	350	405	258	113	42	110	10	70	45	12	
	AD6/P	495	457		163	420	475	375	475	298	114	48	110	10	80	51.5	14	
	AD7/P	650	570		170	420	475	375	475	292	112	55	110	10	90	59	16	
K..187	AD5/P	430	355	550	153	480	545	380	495	258	113	42	110	10	70	45	12	
	AD6/P	495	457		163	485	525	380	475	298	114	48	110	10	80	51.5	14	
	AD7/P	650	570		170	485	525	380	475	292	112	55	110	10	90	59	16	

10.9 K.. AR.. [dimensions]

K.. AR..

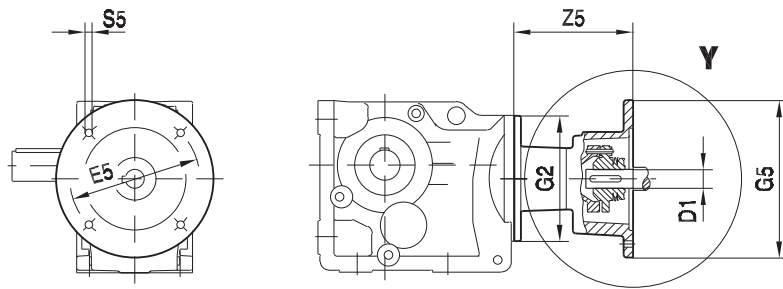

33 037 02 01

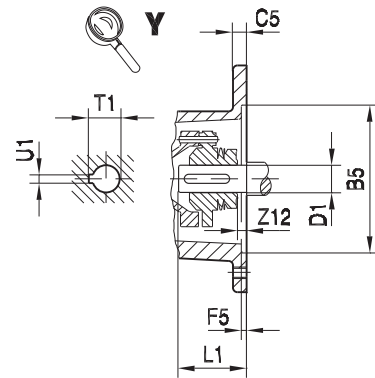

K.. AR../W

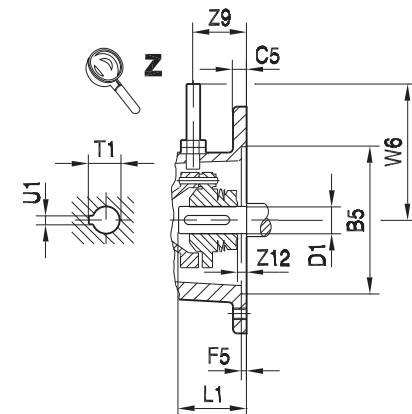
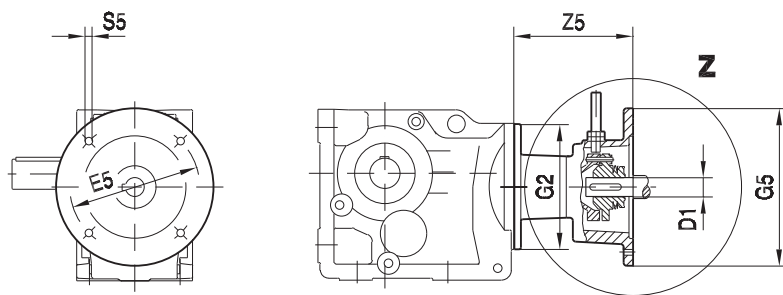

		B5	C5	E5	F5	G2	G5	S5	W6	Z5	Z9	Z12	D1	L1	T1	U1			
K..19	AR71	110	10	130	3.5	120	160	M8	120	104	37	0	14	30	16.3	5			
K..29	AR80	130	12	165	4.5		200	M10		140.5			19	40	21.8	6			
K..37	AR90						24	50		27.3			8						
K..39	AR71	110	10	130	3.5	160	160	M8	120	97.5	37	0	14	30	16.3	5			
K..47	AR80	130	12	165	4.5		200	M10		134			19	40	21.8	6			
K..57	AR90						24	50		27.3			8						
K..67	AR100	180	15	215	5		250	M12		130			174.5	52	5.5	28	60	31.3	8
	AR112					28	60	31.3	8										
K..49	AR71	110	10	130	3.5	200	160	M8	120	91.5	37	0	14	30	16.3	5			
K..77	AR80	130	12	165	4.5		200	M10		127			19	40	21.8	6			
	AR90						24	50		27.3			8						
	AR100	180	15	215	5		250	M12		130			166.5	52	5.5	28	60	31.3	8
	AR112						28	60		31.3			8						
	AR132S/M	230	16	265	5		300	M12		145			234	72	5	38	80	41.3	10
	AR132ML					38	80	41.3	10										
K..87	AR80	130	12	165	4.5	250	200	M10	120	122	37	0	19	40	21.8	6			
	AR90						24	50		27.3			8						
	AR100	180	15	215	5		250	M12		130			161.5	52	5.5	28	60	31.3	8
	AR112						28	60		31.3			8						
	AR132S/M	230	16	265	5		300	M12		145			229	72	5	38	80	41.3	10
	AR132ML						38	80		41.3			10						
	AR160	250	18	300	6	350	M16	165	306.5	105	35	42	110	45.3	12				
	AR180					48	110	51.8	14										

10 K - Helical Bevel

K.. AR.. [dimensions]

K.. AR..

33 038 02 01

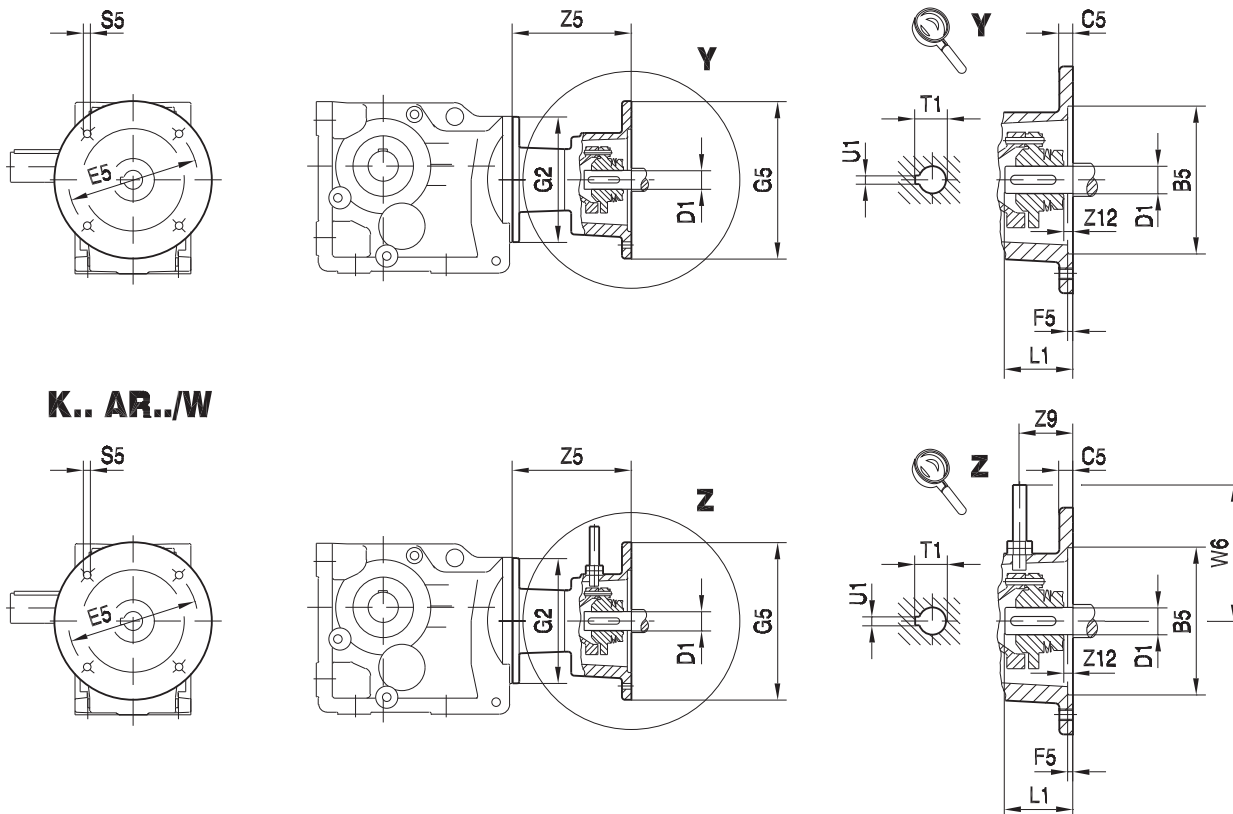

K.. AR../W

		B5	C5	E5	F5	G2	G5	S5	W6	Z5	Z9	Z12	D1	L1	T1	U1
K..97	AR100	180	15	215	5	300	250	M12	130	156.5	52	5.5	28	60	31.3	8
	AR112															
	AR132S/M	230	16	265	5		300	M12	145	224	72	5	38	80	41.3	10
	AR132ML															
	AR160															
AR180	250	18	300	6	350	M16	165	301.5	105	35	42	110	45.3	12		
		48	110	51.8	14											
K..107	AR100	180	15	215	5	350	250	M12	130	150.5	52	5.5	28	60	31.3	8
	AR112															
	AR132S/M	230	16	265	5		300	M12	145	218	72	5	38	80	41.3	10
	AR132ML															
	AR160															
AR180	250	18	300	6	350	M16	165	295.5	105	35	42	110	45.3	12		
		48	110	51.8	14											
K..127	AR132S/M	230	16	265	5	450	300	M12	145	203	72	5	38	80	41.3	10
	AR132ML															
	AR160	250	18	300	6		350	M16	165	280.5	105	35	42	110	45.3	12
	AR180															
K..157 K..167 K..187	AR160	250	18	300	6	550	350	M16	165	272.5	105	35	42	110	45.3	12
	AR180															

10.10 Output shaft sizes

10.10.1 Solid shaft - Inch

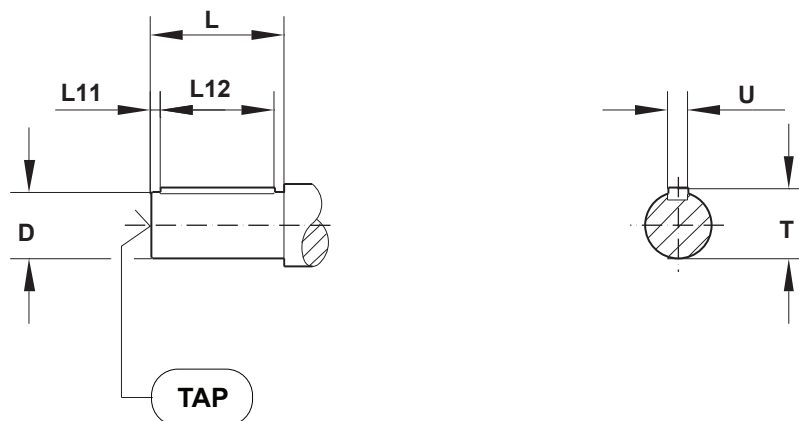

All dimensions in inches								
Model	D	T	U	L ¹⁾	L11	L12	TAP	Change ²⁾
K..19	0.75	0.83	3/16	1.57	0.25	1-1/16	1/4 - 20 x 0.63	0
K..29	1.00	1.11	1/4	1.97	0.32	1-5/16	3/8 - 16 x 0.87	0
K..37	1.00	1.11	1/4	1.97	0.32	1-5/16	3/8 - 16 x 0.87	0
K..39	1.00	1.11	1/4	1.97	0.32	1-5/16	3/8 - 16 x 0.87	-0.39
	1.25	1.36	1/4	2.36	0.26	1-11/16	1/2 - 13 x 1.12	0
K..47	1.25	1.36	1/4	2.36	0.26	1-11/16	1/2 - 13 x 1.12	0
K..49	1.375	1.51	5/16	2.76	0.43	1-13/16	1/2 - 13 x 1.12	0
K..57 ..	1.375	1.51	5/16	2.76	0.43	1-13/16	1/2 - 13 x 1.12	0
K..67	1.375	1.51	5/16	2.76	0.47	1-13/16	1/2 - 13 x 1.12	-0.39
	1.625	1.79	3/8	3.15	0.38	2-3/8	5/8 - 11 x 1.38	0
K..77	1.75	1.92	3/8	3.54	0.4	2-3/4	5/8 - 11 x 1.38	-0.40
	2	2.22	1/2	3.94	0.64	2-5/8	3/4 - 10 x 1.61	0
K..87	2.375	2.65	5/8	4.72	0.51	3-5/8	3/4 - 10 x 1.61	0
K..97	2.875	3.2	3/4	5.51	0.67	4-1/8	3/4 - 10 x 1.61	0
K..107	3.625	4.01	7/8	6.69	0.63	5-3/8	1 - 8 x 2.13	0
K..127	4.375	4.82	1	8.27	1.09	6	1 - 8 x 2.13	0
K..157	4.75	5.29	1-1/4	8.27	0.82	6-9/16	1 - 8 x 2.13	0
K167	6.25	6.65	1-1/2	9.84	0.59	7-1/8	1-1/8 - 7 x 2.13	0
K187	7.5	8.27	1-3/4	12.6	0.39	10	1-1/8 - 7 x 2.13	0

1) Longer shafts to match older designs are available for flanged units.

2) The change in length, L, when compared to the standard shaft that is shown in dimension pages.

10 K - Helical Bevel

Output shaft sizes

10.10.2 Solid shaft - Metric

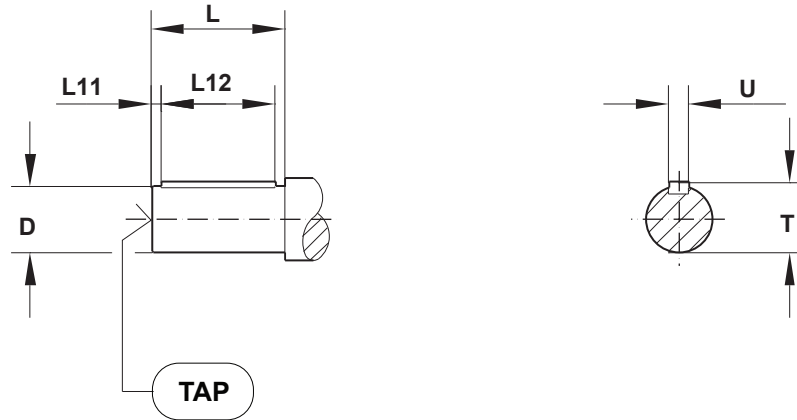

All dimensions in mm							
Model	D	T	U	L ¹⁾	L11	L12	TAP
K..19	20	22.5	6	40	4	32	M6 x 16
K..29	25	28	8	50	5	40	M10 x 22
K..37	25	28	8	50	5	40	M10 x 22
K..39	30	33	8	60	3.5	50	M10 x 22
K..47	30	33	8	60	3.5	50	M10 x 22
K..49	35	38	10	70	7	56	M12 x 28
K..57	35	38	10	70	7	56	M12 x 28
K..67	35	38	10	70	7	56	M12 x 28
	40	43	12	80	5	70	M16 x 36
K..77	45	48.5	14	90	5	80	M16 x 36
	50	53.5	14	100	10	80	M16 x 36
K..87	60	64	18	120	5	110	M20 x 42
K..97	70	74.5	20	140	7.5	125	M20 x 42
K..107	90	95	25	170	5	160	M24 x 50
K..127	110	116	28	210	15	180	M24 x 50
K..157	120	127	32	210	5	200	M24 x 50
K167	160	169	40	250	15	220	M30 x 63
K187	190	200	45	320	10	300	M30 x 63

1) Longer shafts to match older designs are available for flanged units.

10.10.3 Hollow shaft - Inch

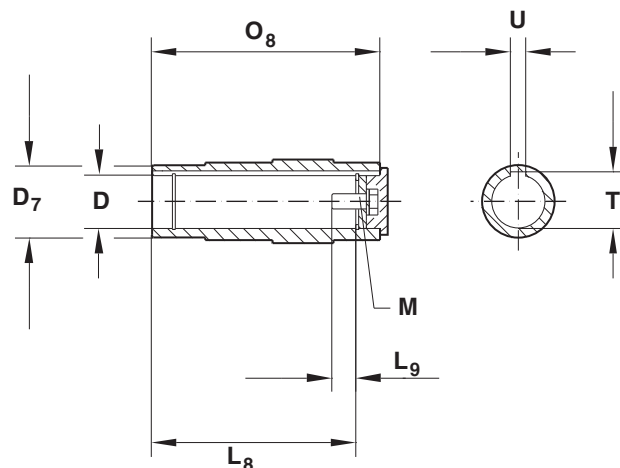

All dimensions in inches								
Model	D	D ₇	O ₈	T	U	L ₈	L ₉	M
KA..19	0.75	1.18	4.25	0.85	3/16	3.62	0.39	1/4 - 20 x 5/8
KA..29	1.00	1.57	4.80	1.12	1/4	4.21	0.69	3/8 - 16 x 1
KA..37	1.25	1.77	4.72	1.37	1/4	4.13	0.67	7/16 - 14 x 1
KA..39	1.25	1.97	6.10	1.37	1/4	5.39	0.67	7/16 - 14 x 1
	1.375	1.97	6.10	1.52	5/16	5.39	0.65	1/2 - 13 x 1
KA..47	1.1875	1.97	5.91	1.30	1/4	5.2	0.67	3/8 - 16 x 1
	1.25	1.97	5.91	1.37	1/4	5.2	0.67	7/16 - 14 x 1
	1.375	1.97	5.91	1.52	5/16	5.2	0.65	1/2 - 13 x 1
	1.4375	1.97	5.91	1.61	3/8	5.2	0.65	5/8 - 11 x 1-3/4
KA..49	1.375	2.17	7.01	1.52	5/16	6.3	0.65	1/2 - 13 x 1
	1.50	2.17	7.01	1.67	3/8	6.3	1.36	5/8 - 11 x 1-3/4
KA..57	1.4375	2.17	6.54	1.61	3/8	5.59	1.36	5/8 - 11 x 1-3/4
	1.50	2.17	6.54	1.67	3/8	5.59	1.36	5/8 - 11 x 1-3/4
KA..67	1.4375	2.17	7.09	1.61	3/8	6.14	1.36	5/8 - 11 x 1-3/4
	1.50	2.17	7.09	1.67	3/8	6.14	1.36	5/8 - 11 x 1-3/4
KA..77	1.9375	2.76	8.27	2.16	1/2	7.2	1.16	5/8 - 11 x 1-3/4
	2.00	2.76	8.27	2.22	1/2	7.2	1.16	5/8 - 11 x 1-3/4
KA..87	2.375	3.35	9.45	2.65	5/8	8.27	1.39	3/4 - 10 x 2
	2.4375	3.35	9.45	2.62	5/8	8.27	1.39	3/4 - 10 x 2
KA..97	2.75	3.74	11.81	3.03	5/8	10.63	1.24	3/4 - 10 x 2
	2.9375	3.74	11.81	3.14	3/4	10.63	1.24	3/4 - 10 x 2
KA..107	3.25	4.65	13.78	3.59	3/4	12.32	1.24	3/4 - 10 x 2
	3.4375	4.65	13.78	3.7	7/8	12.32	1.24	3/4 - 10 x 2
	3.625	4.65	13.78	3.89	7/8	12.32	1.24	3/4 - 10 x 2
KA..127	4.00	5.31	16.14	4.44	1	14.69	1.26	1 - 8 x 2-1/4
KA..157	4.50	6.1	19.69	4.95	1	18.11	1.26	1 - 8 x 2-1/4

10.10.4 Hollow shaft - Metric

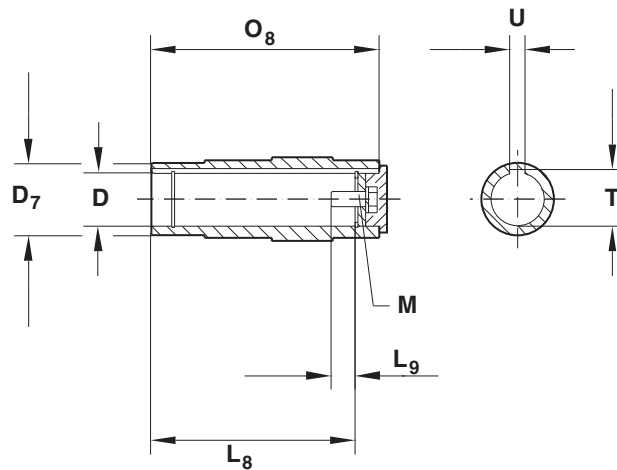

All dimensions in mm								
Model	D	D ₇	O ₈	T	U	L ₈	L ₉	M
KA..19	20	30	108	22.8	6	92	8	M6 x 16
KA..29	25	40	122	27	8	107	17	M10 x 25
KA..37	30	45	120	33.3	8	105	17	M10 x 25
KA..39	30	50	155	33.3	8	137	17	M10 x 25
	35	50	155	38.3	10	137	17	M12 x 30
KA..47	30	50	150	33.3	8	132	16	M10 x 25
	35	50	150	38.3	10	132	22	M12 x 30
KA..49	35	55	178	38.3	10	160	22	M12 x 30
	40	55	178	43.3	12	160	22	M12 x 30
KA..57	40	55	166	43.3	12	142	29	M16 x 40
KA..67	40	55	180	43.3	12	156	29	M16 x 40
KA..77	50	70	210	53.8	14	183	32	M16 x 45
KA..87	60	85	240	64.4	18	210	36	M20 x 50
KA..97	70	95	300	74.9	20	270	34	M20 x 50
KA..107	80	118	350	85.4	22	313	30	M20 x 50
	90	118	350	95.4	25	313	40	M24 x 60
KA..127	100	135	410	106.4	28	373	38	M24 x 60
KA..157	120	155	500	127.4	32	460	36	M24 x 60

10.10.5 TorqLOC keyless hollow shaft

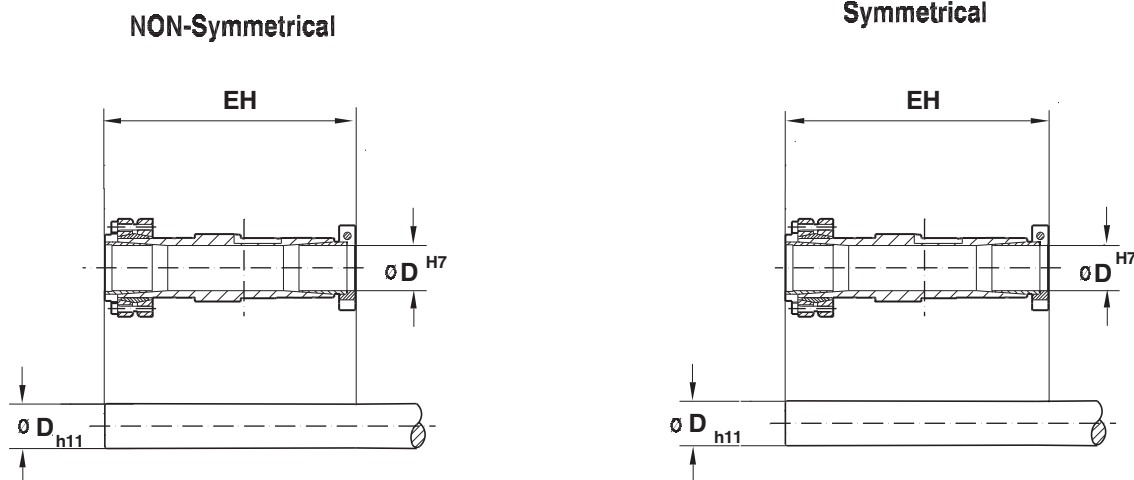

Metric and inch bores are available as shown below.

Model	D (in)					D (mm)			EH (inches)	
	Inch Bores					Metric Bores			NON-Symmetrical	Symmetrical
KT37	1.00	1.1875	1.25	-	-	25	30	-	6.69	7.63
KT39	1.1875	1.25	1.375	1.4375	-	30	35	-	8.23	-
KT47	1.1875	1.25	1.375	1.4375	-	30	35	-	8.15	9.13
KT49	1.375	1.4375	1.50	1.625	1.6875	35	40	-	9.57	-
KT57	1.375	1.4375	1.50	1.625	-	35	38	40	9.13	10.39
KT67	1.375	1.4375	1.50	1.625	1.6875	35	38	40	9.65	10.91
KT77	1.625	1.75	1.9375	2.00	-	50	-	-	11.61	13.34
KT87	1.9375	2.00	2.375	2.4375	-	51	62	65	13.19	15.28
KT97	2.4375	2.75	2.9375	-	-	62	70	75	15.59	17.79
KT107	3.250	3.4375	3.625	3.750	-	80	90	95	17.76	20.08
KT127	3.4375	3.750	4.00	4.1875	-	105	-	-	20.94	23.89
KT157	4.4375	4.50	4.9375	5.00	-	110	125	-	25.24	28.39

11 S - Helical Worm

11.1 S.. AM

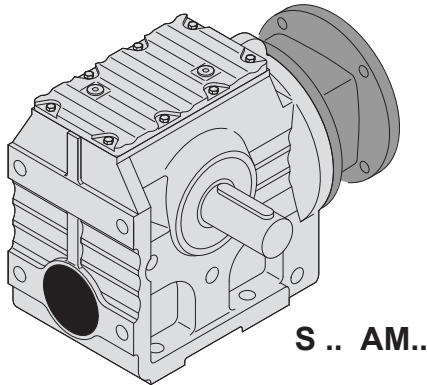

S .. AM..

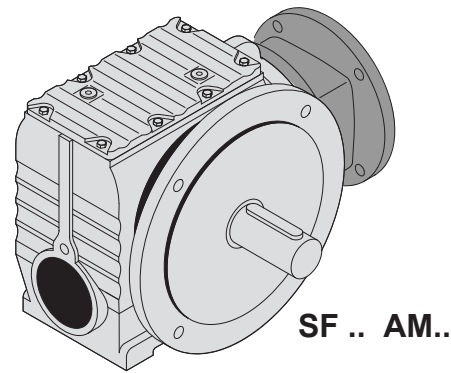

SF .. AM..

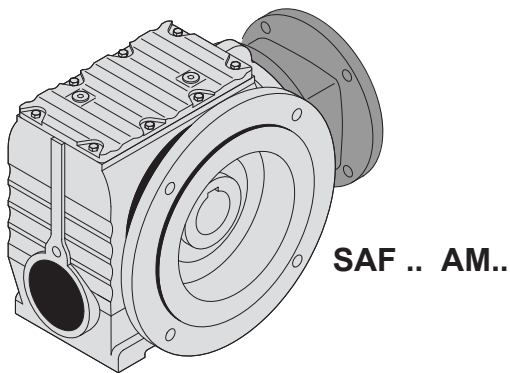

SAF .. AM..

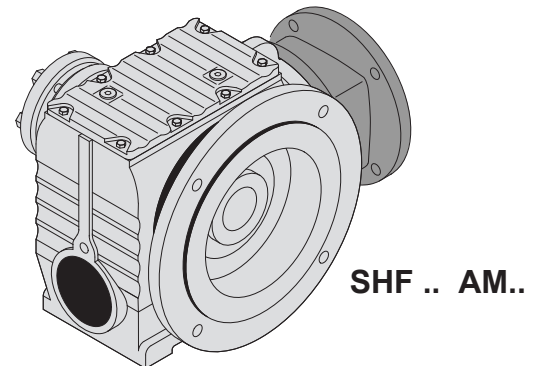

SHF .. AM..

50413axx

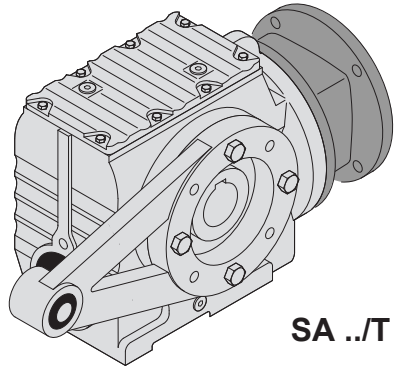

SA ..T AM..

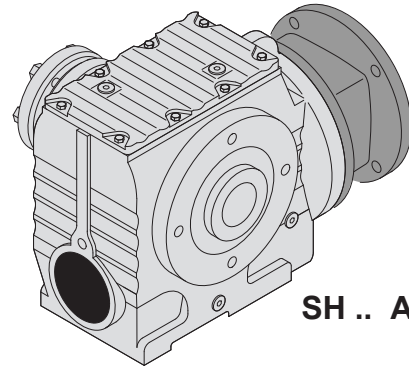

SH .. AM..

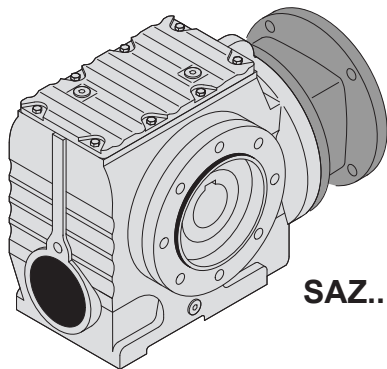

SAZ.. AM..

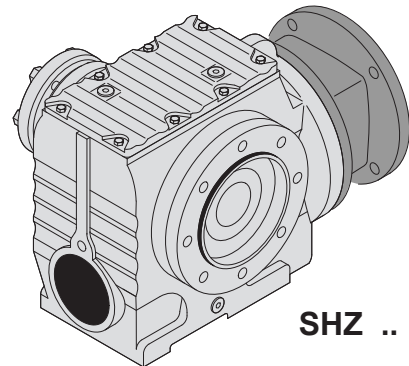

SHZ .. AM..

50414axx

11.1.1 S37

S37, n _e = 1700 rpm						800 lb-in		
Stages	i [ratio]	n _a [rpm]	T _{a max} [lb-in]	F _{Ra} [lb]	Φ (/R) [']	AM		
						56	143	145
	3.97	428	280	285	-			
	4.86	350	290	310	-			
	5.38	316	300	325	-			
	6.33	269	305	345	-			
	6.80	250	360	340	-			
	8.00	212	380	360	-			
	9.02	188	380	380	-			
	10.23	166	395	395	-			
	10.91	156	395	410	-			
	12.48	136	405	430	-			
	13.39	127	415	440	-			
	15.53	109	420	470	-			
	18.24	93	430	500	-			
	19.13	89	600	495	-			
	19.89	85	440	515	-			
	22.50	76	615	530	-			
	25.38	67	625	555	-			
	28.76	59	645	580	-			
	30.68	55	645	600	-			
	35.10	48	660	630	-			
	37.66	45	670	645	-			
	43.68	39	690	675	-			
	51.30	33	705	675	-			
	53.83	32	670	675	-			
	55.93	30	715	675	-			
	63.33	27	695	675	-			
	71.44	24	705	675	-			
	80.96	21	725	675	-			
	86.36	20	725	675	-			
	98.80	17	750	675	-			
	106.00	16	760	675	-			
	122.94	14	765	675	-			
	144.40	12	795	675	-			
	157.43	11	800	675	-			

Weight [lbs]		Stages	56	AM 143	145
S37	NEMA	2	21	25	25
			71	80	90
	IEC	2	20	25	25

SA37: -1 lbs / SAF37: +3 lbs / SF37: +3 lbs

11.1.2 S47

S47, n_e = 1700 rpm						1500 lb-in		
Stages	i [ratio]	n _a [rpm]	T _{a max} [lb-in]	F _{Ra} [lb]	Φ (/R) [']	AM		
						56	143	145
	4.00	425	420	445	-			
	4.76	357	510	450	-			
	5.39	315	575	455	-			
	6.40	266	670	465	-			
	6.83	249	690	470	-			
	7.28	234	760	475	-			
	8.64	197	880	475	-			
	9.23	184	920	480	-			
	10.80	157	950	510	-			
	12.10	140	960	540	-			
	14.24	119	960	585	-			
	16.47	103	960	630	-			
	17.62	96	960	650	-			
	19.54	87	1080	735	-			
	20.33	84	970	690	-			
	23.20	73	1250	755	-			
	24.77	69	1280	770	-			
S47  2	29.00	59	1360	810	-			
	32.48	52	1370	850	-			
	38.23	44	1370	910	-			
	44.22	38	1370	970	-			
	47.32	36	1370	1000	-			
	54.59	31	1370	1070	-			
	56.61	30	1340	1120	-			
	63.80	27	1370	1140	-			
	67.20	25	1450	1190	-			
	69.39	24	1370	1180	-			
	71.75	24	1470	1200	-			
	84.00	20	1470	1200	-			
	94.08	18	1470	1200	-			
	110.73	15	1470	1200	-			
	128.10	13	1470	1200	-			
	137.05	12	1470	1200	-			
	158.12	11	1480	1200	-			
	184.80	9.2	1480	1200	-			
	201.00	8.5	1500	1200	-			

Weight [lbs]		Stages	56	AM 143	145
S47	NEMA	2	27	32	32
			71	80	90
	IEC	2	26	32	32

SA47: +3 lbs / SAF47: +6 lbs / SF47: +8 lbs

11.1.3 S57

S57, n _e = 1700 rpm						2610 lb-in		
Stages	i [ratio]	n _a [rpm]	T _{a max} [lb-in]	F _{Ra} [lb]	Φ (i/R) [']	56	AM 143	145
	4.00	425	625	740	-			
	4.76	357	740	765	-			
	5.39	315	840	780	-			
	6.40	266	860	830	-			
	6.83	249	880	850	-			
	7.28	234	1070	830	-			
	8.64	197	1240	850	-			
	9.23	184	1310	860	-			
	10.80	157	1490	880	-			
	12.10	140	1490	930	-			
	14.24	119	1490	1000	-			
	16.47	103	1480	1070	-			
	17.62	96	1480	1100	-			
	19.54	87	1610	1240	-			
	20.33	84	1480	1180	-			
	23.20	73	1850	1280	-			
	24.77	69	1940	1300	-			
S57  2	29.00	59	2160	1350	-			
	32.48	52	2160	1420	-			
	38.23	44	2160	1520	-			
	44.22	38	2160	1610	-			
	47.32	36	2160	1660	-			
	54.59	31	2160	1690	-			
	56.61	30	1990	1720	-			
	63.80	27	2160	1690	-			
	67.20	25	2300	1670	-			
	69.39	24	2160	1690	-			
	71.75	24	2430	1640	-			
	84.00	20	2520	1620	-			
	94.08	18	2610	1590	-			
	110.73	15	2610	1600	-			
	128.10	13	2610	1600	-			
	137.05	12	2610	1600	-			
	158.12	11	2610	1600	-			
	184.80	9.2	2610	1600	-			
	201.00	8.5	2610	1600	-			

11

Weight [lbs]		Stages	56	AM 143	145
S57	NEMA	2	36	40	40
			71	80	90
	IEC	2	35	40	40

SA57: -1 lbs / SAF57: +6 lbs / SF57: +8 lbs

11.1.4 S67

S67, n _e = 1700 rpm						4600 lb-in					
Stages	i [ratio]	n _a [rpm]	T _a max [lb-in]	F _{Ra} [lb]	φ (/R) [']	AM					
						56	143	145	182	184	213/215
	7.56	225	2210	795	-						
	8.69	196	2470	755	-						
	10.03	169	2780	700	-						
	11.03	154	3000	655	-						
	12.96	131	3000	795	-						
	13.73	124	3000	840	-						
	15.60	109	3000	960	-						
	17.28	98	3000	1030	-						
	20.30	84	3180	1270	-						
	20.37	83	3000	1120	-						
	23.22	73	3000	1200	-						
	23.33	73	3580	1290	-						
	24.44	70	3000	1230	-						
	26.93	63	4020	1310	-						
	29.63	57	4240	1340	-						
	34.80	49	4240	1450	-						
	36.85	46	4240	1490	-						
S67  2	41.89	41	4240	1580	-						
	46.40	37	4240	1660	-						
	54.70	31	4240	1790	-						
	58.80	29	4070	1950	-						
	62.35	27	4240	1890	-						
	65.63	26	4240	1940	-						
	67.57	25	4370	2000	-						
	75.06	23	4240	2030	-						
	78.00	22	4510	1970	-						
	85.83	20	4600	1950	-						
	100.80	17	4600	1950	-						
	106.75	16	4600	1950	-						
	121.33	14	4600	1950	-						
	134.40	13	4600	1950	-						
	158.45	11	4600	1950	-						
180.60	9.4	4600	1950	-							
190.11	8.9	4600	1950	-							
217.41	7.8	4600	1950	-							

Weight [lbs]		Stages	AM					
			56	143	145	182	184	213/215
S67	NEMA	2	61	65	65	73	73	85
			71	80	90	100	112	132S/M
	IEC	2	60	65	65	75	75	91

SA67: +2 lbs / SAF67: +12 lbs / SF67: +14 lbs

11.1.5 S67R37

S67R37, $n_e = 1700$ rpm							5040 lb-in		
i [ratio]	n_a [rpm]	T_a max [lb-in]	F_{Ra} ¹⁾ [lb]	Stages		Φ (/R) [']	56	AM	
				Lg	Sm			143	145
156	11	5040	1840	2	2	-			
168	10	5040	1840	2	2	-			
198	8.6	5040	1840	2	2	-			
221	7.7	5040	1840	2	2	-			
246	6.9	5040	1840	2	2	-			
281	6.0	5040	1840	2	2	-			
319	5.3	5040	1840	2	2	-			
365	4.7	5040	1840	2	2	-			
424	4.0	5040	1840	2	2	-			
469	3.6	5040	1840	2	2	-			
543	3.1	5040	1840	2	2	-			
615	2.8	5040	1840	2	2	-			
712	2.4	5040	1840	2	2	-			
809	2.1	5040	1840	2	2	-			
914	1.9	5040	1840	2	3	-			
1045	1.6	5040	1840	2	3	-			
1194	1.4	5040	1840	2	3	-			
1363	1.2	5040	1840	2	3	-			
1559	1.1	5040	1840	2	3	-			
1772	0.96	5040	1840	2	3	-			
2014	0.84	5040	1840	2	3	-			
2279	0.75	5040	1840	2	3	-			
2630	0.65	5040	1840	2	3	-			
2944	0.58	5040	1840	2	3	-			
3432	0.50	5040	1840	2	3	-			
3880	0.44	5040	1840	2	3	-			
4410	0.39	5040	1840	2	3	-			
4965	0.34	5040	1840	2	3	-			
5759	0.30	5040	1840	2	3	-			
6531	0.26	5040	1840	2	3	-			
7455	0.23	5040	1840	2	3	-			
8529	0.20	5040	1840	2	3	-			
9694	0.18	5040	1840	2	3	-			
11013	0.15	5040	1840	2	3	-			
12774	0.13	5040	1840	2	3	-			
14383	0.12	5040	1840	2	3	-			
16682	0.10	5040	1840	2	3	-			
18120	0.09	5040	1840	2	3	-			
19594	0.09	5040	1840	2	3	-			
21362	0.08	5040	1840	2	3	-			

11

Weight [lbs]		Stages		56	AM	
		Large	Small		143	145
S67R37	NEMA	2	2	84	88	88
		2	3	84	89	89
			71	80	90	
	IEC	2	2	83	88	88
		2	3	83	89	89
	SA67: +2 lbs / SAF67: +12 lbs / SF67: +14 lbs					

11.1.6 S77

S77, n _e = 1700 rpm						11200 lb-in					
Stages	i [ratio]	n _a [rpm]	T _{a max} [lb-in]	F _{Ra} [lb]	Φ _(/R) [']	AM					
						56	143	145	182	184	213/215
	8.06	211	5080	325	-						
	9.44	180	5790	161	-						
	10.65	160	6370	11	-						
	12.07	141	6370	152	-						
	13.76	124	6280	325	-						
	15.28	111	6280	455	-						
	17.45	97	6280	665	-						
	18.42	92	6230	735	-						
	18.97	90	7600	1360	-						
	20.99	81	6230	930	-						
	22.22	77	8140	1420	-						
	22.89	74	6230	1050	-						
	25.07	68	8490	1470	-						
	28.41	60	8750	1550	-						
	32.38	53	9200	1610	-						
	35.94	47	9370	1680	-						
	41.07	41	9730	1770	-						
S77  2	43.33	39	9730	1820	-						
	49.38	34	9730	1960	-						
	53.87	32	9730	2050	-						
	56.92	30	8140	2460	-						
	63.03	27	9730	2220	-						
	66.67	25	8580	2590	-						
	71.33	24	9730	2370	-						
	75.09	23	9730	2430	-						
	75.20	23	8930	2700	-						
	85.22	20	9290	2820	-						
	97.14	18	9640	2950	-						
	107.83	16	9820	2930	-						
	123.20	14	10100	2860	-						
	130.00	13	10300	2830	-						
	148.15	11	10600	2770	-						
	161.60	11	10700	2730	-						
	189.09	9.0	10900	2690	-						
	214.00	7.9	11200	2630	-						
	225.26	7.5	11200	2630	-						
	256.47	6.6	11200	2630	-						

Weight [lbs]		Stages	AM					
			56	143	145	182	184	213/215
S77	NEMA	2	105	110	110	115	115	130
			71	80	90	100	112	132S/M
	IEC	2	105	110	110	120	120	135

SA77: -1.0 lbs / SAF77: +14 lbs / SF77: +21 lbs

11.1.7 S77R37

S77R37, $n_e = 1700$ rpm							11240 lb-in		
i [ratio]	n_a [rpm]	T_a max [lb-in]	$F_{Ra}^{1)}$ [lb]	Stages		ϕ (/R) [']	AM		
				Lg	Sm		56	143	145
219	7.8	10970	2690	2	2	-			
250	6.8	10970	2690	2	2	-			
289	5.9	10970	2690	2	2	-			
327	5.2	10970	2690	2	2	-			
389	4.4	10970	2690	2	2	-			
438	3.9	10970	2690	2	2	-			
499	3.4	10970	2690	2	2	-			
574	3.0	10970	2690	2	2	-			
637	2.7	10970	2690	2	2	-			
714	2.4	10970	2690	2	2	-			
837	2.0	10970	2690	2	2	-			
954	1.8	10970	2690	2	2	-			
1100	1.5	10970	2690	2	2	-			
1245	1.4	10970	2690	2	3	-			
1404	1.2	10970	2690	2	3	-			
1600	1.1	10970	2690	2	3	-			
1745	0.97	10970	2690	2	3	-			
1813	0.94	10970	2690	2	3	-			
2083	0.82	10970	2690	2	3	-			
2374	0.72	10970	2690	2	3	-			
2753	0.62	10970	2690	2	3	-			
3098	0.55	11240	2630	2	3	-			
3540	0.48	11240	2630	2	3	-			
3992	0.43	11240	2630	2	3	-			
4618	0.37	11240	2630	2	3	-			
5214	0.33	11240	2630	2	3	-			
5943	0.29	11240	2630	2	3	-			
6735	0.25	11240	2630	2	3	-			
7735	0.22	11240	2630	2	3	-			
8817	0.19	11240	2630	2	3	-			
9887	0.17	11240	2630	2	3	-			
11569	0.15	11240	2630	2	3	-			
13110	0.13	11240	2630	2	3	-			
14668	0.12	11240	2630	2	3	-			
17013	0.10	11240	2630	2	3	-			
19907	0.09	11240	2630	2	3	-			
21787	0.08	11240	2630	2	3	-			
25493	0.07	11240	2630	2	3	-			

11

Weight [lbs]		Stages		AM		
		Large	Small	56	143	145
S77R37	NEMA	2	2	125	130	130
		2	3	125	130	130
			71	80	90	
	IEC	2	2	125	130	130
		2	3	125	130	130
	SA77: -1.0 lbs / SAF77: +14 lbs / SF77: +21 lbs					

11.1.8 S87

S87, n_e = 1700 rpm 20100 lb-in

Stages	i [ratio]	n _a [rpm]	T _{a max} [[b-in]	F _{Ra} [lb]	Φ (R) [']	AM						
						143	145	182	184	213/215	254/256	284/286
S87  2	7.88	216	7340	3490	-							
	9.07	187	8400	3530	-							
	10.93	156	9990	3580	-							
	12.21	139	10900	3480	-							
	14.06	121	10900	3830	-							
	15.64	109	10900	4000	-							
	17.49	97	10900	4190	-							
	19.70	86	10900	4400	-							
	20.27	84	12500	4760	-							
	21.43	79	10900	4550	-							
	24.43	70	14100	4950	-							
	25.50	67	10900	4870	-							
	27.28	62	14100	5160	-							
	31.43	54	14100	5440	-							
	34.96	49	14100	5660	-							
	39.10	43	14100	5900	-							
	44.03	39	14100	6160	-							
	47.91	35	14100	6360	-							
	57.00	30	14100	6520	-							
	64.00	27	13900	6530	-							
	64.27	26	14100	6520	-							
	70.43	24	14100	6520	-							
	77.14	22	15000	6500	-							
	81.76	21	14100	6520	-							
	86.15	20	15600	6470	-							
	91.20	19	13300	6540	-							
	99.26	17	16200	6450	-							
	110.40	15	16800	6430	-							
	123.48	14	17300	6410	-							
	139.05	12	17800	6380	-							
151.30	11	18200	6370	-								
180.00	9.4	18800	6340	-								
202.96	8.4	19300	6320	-								
222.40	7.6	19500	6310	-								
258.18	6.6	19900	6290	-								
288.00	5.9	20100	6280	-								

Weight [lbs]		Stages	AM						
			143	145	182	184	213/215	254/256	284/286
S87	NEMA	2	185	185	195	195	210	240	245
			80	90	100	112	132S/M	160	180
	IEC	2	185	185	200	200	215	250	250

SA87: -5.0 lbs / SAF87: +30 lbs / SF87: +48 lbs

11.1.9 S87R57

S87R57, $n_e = 1700$ rpm							22130 lb-in					
i [ratio]	n_a [rpm]	$T_{a \max}$ [lb-in]	$F_{Ra}^{1)}$ [lb]	Stages		ϕ (/R) [']	AM					
				Lg	Sm		56	143	145	182	184	213/215
205	8.3	17520	6390	2	2	-						
222	7.7	17520	6390	2	2	-						
255	6.7	17520	6390	2	2	-						
281	6.0	21240	6230	2	2	-						
323	5.3	21240	6230	2	2	-						
378	4.5	21680	6210	2	2	-						
435	3.9	21680	6210	2	2	-						
485	3.5	22130	6180	2	2	-						
558	3.0	22130	6180	2	2	-						
624	2.7	22130	6180	2	2	-						
719	2.4	22130	6180	2	2	-						
831	2.0	22130	6180	2	2	-						
930	1.8	22130	6180	2	2	-						
1032	1.6	22130	6180	2	2	-						
1191	1.4	22130	6180	2	2	-						
1332	1.3	22130	6180	2	2	-						
1631	1.0	22130	6180	2	2	-						
1824	0.93	22130	6180	2	2	-						
2054	0.83	22130	6180	2	2	-						
2335	0.73	22130	6180	2	2	-						
2586	0.66	22130	6180	2	2	-						
2905	0.59	22130	6180	2	2	-						
3475	0.49	22130	6180	2	2	-						
3872	0.44	22130	6180	2	3	-						
4606	0.37	22130	6180	2	3	-						
5187	0.33	22130	6180	2	3	-						
5875	0.29	22130	6180	2	3	-						
6706	0.25	22130	6180	2	3	-						
7643	0.22	22130	6180	2	3	-						
8549	0.20	22130	6180	2	3	-						
9904	0.17	22130	6180	2	3	-						
11200	0.15	22130	6180	2	3	-						
13160	0.13	22130	6180	2	3	-						
14820	0.11	22130	6180	2	3	-						
16774	0.10	22130	6180	2	3	-						
18265	0.09	22130	6180	2	3	-						
20568	0.08	22130	6180	2	3	-						
23940	0.07	22130	6180	2	3	-						
25987	0.07	22130	6180	2	3	-						

11

Weight [lbs]		Stages		AM					
		Large	Small	56	143	145	182	184	213/215
S87R57	NEMA	2	2	233	238	238	246	246	260
		2	3	235	240	240	248	248	262
			71	80	90	100	112	132S/M	
	IEC	2	2	233	238	238	248	248	264
2		3	235	240	240	250	250	266	

SA87: -5.0 lbs / SAF87: +30 lbs / SF87: +48 lbs

11.1.10 S97

S97, n _e = 1700 rpm						35300 lb-in						
Stages	i [ratio]	n _a [rpm]	T _{a max} [lb-in]	F _{Ra} [lb]	φ (/R) [']	AM						
						182	184	213/215	254/256	284/286	324/326	364/365
S97  2	8.26	206	12700	4220	-							
	9.55	178	14700	4230	-							
	11.41	149	17600	4170	-							
	13.07	130	19200	4080	-							
	15.42	110	20300	4220	-							
	17.05	100	21200	4260	-							
	19.23	88	22100	4370	-							
	21.23	80	22700	4510	-							
	23.59	72	23000	4790	-							
	24.13	70	23600	5960	-							
	26.39	64	23000	5210	-							
	27.63	62	24800	6180	-							
	32.60	52	26300	6480	-							
	36.05	47	27500	6650	-							
	40.65	42	28500	6880	-							
	44.89	38	29100	7110	-							
	49.87	34	29100	7410	-							
	55.79	30	29100	7740	-							
	60.59	28	29100	7750	-							
	65.45	26	23400	7960	-							
	71.43	24	29100	7750	-							
	78.26	22	25300	7900	-							
	80.85	21	28500	7760	-							
	89.60	19	26700	7850	-							
	105.71	16	28400	7780	-							
	116.92	15	29500	7740	-							
	131.85	13	30400	7700	-							
	145.60	12	31400	7650	-							
161.74	11	32200	7610	-								
180.95	9.4	33300	7560	-								
196.52	8.7	33900	7530	-								
231.67	7.3	35000	7480	-								
262.22	6.5	35300	7460	-								
286.40	5.9	35300	7460	-								

Weight [lbs]		Stages	AM						
			182	184	213/215	254/256	284/286	324/326	364/365
S97	NEMA	2	325	325	340	370	375	415	415
			100	112	132S/M	160	180	200	225
	IEC	2	330	330	345	380	385	420	430

SA97: -12 lbs / SAF97: +46 lbs / SF97: +72 lbs

11.1.11 S97R57

S97R57, n _e = 1700 rpm							37170 lb-in					
i [ratio]	n _a [rpm]	T _{a max} [lb-in]	F _{Ra} ¹⁾ [lb]	Stages		Φ (i/R) [']	AM					
				Lg	Sm		56	143	145	182	184	213/215
205	8.3	37170	7100	2	2	-						
219	7.8	37170	7100	2	2	-						
252	6.7	37170	7090	2	2	-						
287	5.9	37170	7080	2	2	-						
327	5.2	37170	7080	2	2	-						
376	4.5	37170	7070	2	2	-						
420	4.0	37170	7060	2	2	-						
484	3.5	37170	7050	2	2	-						
538	3.2	37170	7050	2	2	-						
626	2.7	37170	7040	2	2	-						
714	2.4	37170	7370	2	2	-						
824	2.1	37170	7040	2	2	-						
928	1.8	37170	7040	2	2	-						
1070	1.6	37170	7040	2	2	-						
1223	1.4	37170	7040	2	2	-						
1394	1.2	37170	7040	2	2	-						
1574	1.1	37170	7040	2	3	-						
1860	0.91	37170	7040	2	3	-						
2081	0.82	37170	7040	2	3	-						
2329	0.73	37170	7040	2	3	-						
2654	0.64	37170	7040	2	3	-						
3108	0.55	37170	7040	2	3	-						
3453	0.49	37170	7040	2	3	-						
4017	0.42	37170	7040	2	3	-						
4444	0.38	37170	7040	2	3	-						
4937	0.34	37170	7040	2	3	-						
5780	0.29	37170	7040	2	3	-						
6640	0.26	37170	7040	2	3	-						
7554	0.23	37170	7370	2	3	-						
8608	0.20	37170	7370	2	3	-						
10078	0.17	37170	7370	2	3	-						
11267	0.15	37170	7370	2	3	-						
12752	0.13	37170	7370	2	3	-						
14576	0.12	37170	7370	2	3	-						
16233	0.10	37170	7370	2	3	-						
18749	0.09	37170	7370	2	3	-						
21537	0.08	37170	7370	2	3	-						
24641	0.07	37170	7370	2	3	-						
27847	0.06	37170	7370	2	3	-						
31154	0.05	37170	7370	2	3	-						
33818	0.05	37170	7370	2	3	-						

11

Weight [lbs]		Stages		AM					
		Large	Small	56	143	145	182	184	213/215
S97R57	NEMA	2	2	365	370	370	378	378	392
		2	3	367	372	372	380	380	394
			71	80	90	100	112	132S/M	
	IEC	2	2	365	370	370	380	380	396
2		3	367	372	372	382	382	398	

SA97: -12 lbs / SAF97: +46 lbs / SF97: +72 lbs

11.2 S.. AD

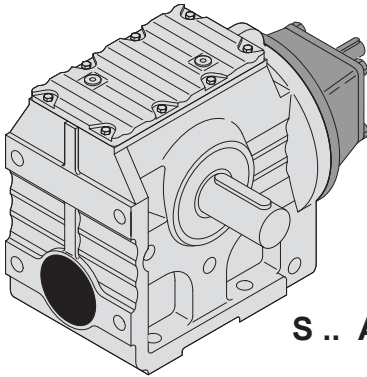

S .. AD..

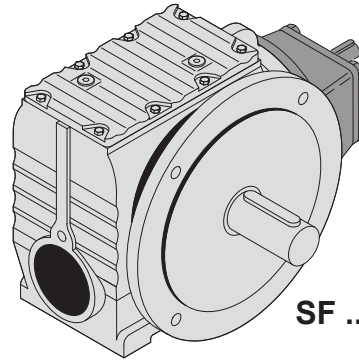

SF .. AD..

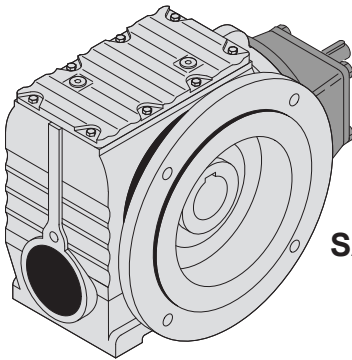

SAF .. AD..

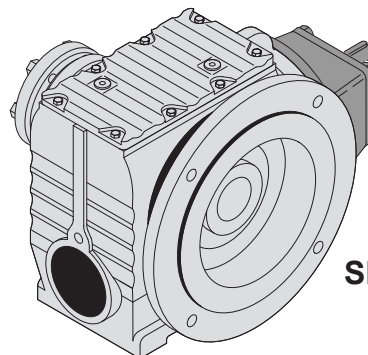

SHF .. AD..

50417AXX

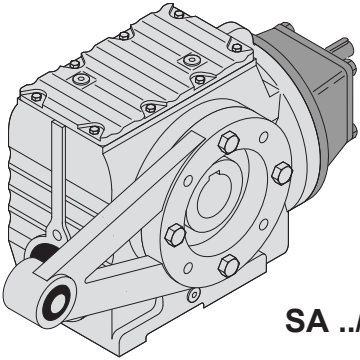

SA .. / T AD..

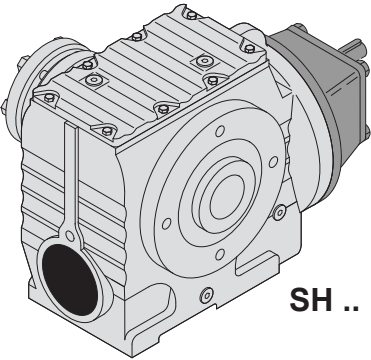

SH .. AD..

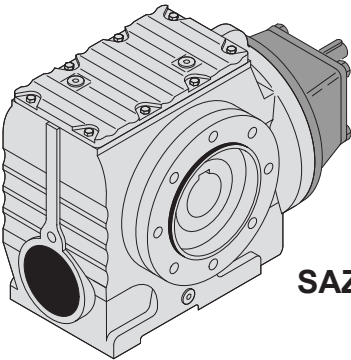

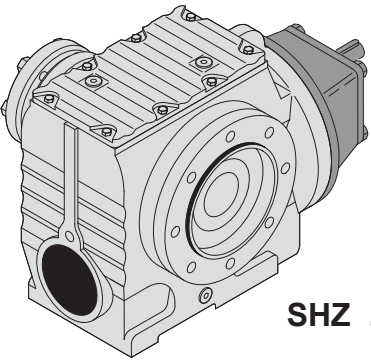

SAZ.. AD..



SHZ .. AD..

50418AXX



11.2.1 S37

S37 AD.. , n _e = 1700 rpm										810 lb-in		
i [ratio]	n _a [rpm]	T _{a max} [lb-in]	P _e [HP]	F _{Ra} ¹⁾ [lb]	F _{Re} [lb]	Stages		φ ^(/R) [']				
						Lg	Sm					
15.53	109	400	0.84	490	70	2	-	-	-			
18.24	93	420	0.76	510	70	2	-	-	-			
19.89	85	430	0.72	530	70	2	-	-	-			
22.50	76	620	0.98	530	110	2	-	-	M1-6			
25.38	67	630	0.89	560	110	2	-	-	M1-6			
28.76	59	650	0.82	580	110	2	-	-	M1-6			
30.68	55	650	0.77	600	110	2	-	-	M1-6			
35.10	48	660	0.69	630	110	2	-	-	M1-6			
37.66	45	670	0.66	650	110	2	-	-	M2-6			
43.68	39	690	0.59	670	120	2	-	-	-			
51.30	33	710	0.53	670	120	2	-	-	-		S37	AD1
55.93	30	720	0.50	670	120	2	-	-	-			
63.33	27	700	0.53	670	160	2	-	-	M1-6			
71.44	24	710	0.48	670	160	2	-	-	M1-6			
80.96	21	730	0.45	670	160	2	-	-	M1-6			
86.36	20	730	0.42	670	160	2	-	-	M1-6			
98.80	17	750	0.39	670	160	2	-	-	M2-6			
106.00	16	760	0.37	670	160	2	-	-	M2-6			
122.94	14	770	0.33	670	160	2	-	-	-			
144.40	12	800	0.30	670	160	2	-	-	-			
157.43	11	810	0.28	670	160	2	-	-	-			
3.97	428	280	2.2	290	340	2	-	-	M1-6			
4.86	350	290	1.9	320	350	2	-	-	M1-6			
5.38	316	300	1.7	330	350	2	-	-	M1-6			
6.33	269	310	1.5	350	350	2	-	-	M1-6			
6.80	250	360	1.7	350	350	2	-	-	M1-6			
8.00	213	380	1.5	370	300	2	-	-	M1-6			
9.02	188	380	1.4	390	310	2	-	-	M1-6			
10.23	166	400	1.3	400	310	2	-	-	M1-6			
10.91	156	400	1.2	420	310	2	-	-	M2-6			
12.48	136	410	1.1	440	310	2	-	-	-			
13.39	127	420	1.0	450	310	2	-	-	-			
15.53	109	420	0.89	480	320	2	-	-	-			
18.24	93	430	0.79	510	320	2	-	-	-			
19.13	89	600	1.1	500	370	2	-	-	M1-6			
19.89	85	440	0.74	520	320	2	-	-	-			
22.50	76	620	0.99	530	370	2	-	-	M1-6			
25.38	67	630	0.90	560	370	2	-	-	M1-6			
28.76	59	650	0.83	580	370	2	-	-	M1-6			
30.68	55	650	0.78	600	370	2	-	-	M1-6			
35.10	48	660	0.71	630	370	2	-	-	M2-6			
37.66	45	670	0.67	650	370	2	-	-	M2,4-6			
43.68	39	690	0.61	670	370	2	-	-	-			
51.30	33	710	0.54	670	370	2	-	-	-			
53.83	32	670	0.60	670	380	2	-	-	M1-6			
55.93	30	720	0.51	670	370	2	-	-	-			
63.33	27	700	0.54	670	380	2	-	-	M1-6			
71.44	24	710	0.50	670	380	2	-	-	M1-6			
80.96	21	730	0.46	670	380	2	-	-	M1-6			
86.36	20	730	0.44	670	390	2	-	-	M1-6			
98.80	17	750	0.40	670	390	2	-	-	M2-6			
106.00	16	760	0.38	670	390	2	-	-	-			
122.94	14	770	0.34	670	390	2	-	-	-			
144.40	12	800	0.31	670	390	2	-	-	-			
157.43	11	810	0.30	670	390	2	-	-	-			

Weight [lbs]	Stages		AD1	AD2
	Large	Small		
S37	2	-	18	21

SA37: -1 lbs / SAF37: +3 lbs / SF37: +3 lbs



11.2.2 S47

S47 AD.. , n _e = 1700 rpm										1500 lb-in		
i [ratio]	n _a [rpm]	T _a max [lb-in]	P _e [HP]	F _{Ra} ¹⁾ [lb]	F _{Re} [lb]	Stages		φ (°/R) [']				
						Lg	Sm					
44.22	38	1250	1.0	1000	80	2	-	-	M1-6	S47	AD1	
47.32	36	1270	0.97	1030	80	2	-	-	M1-6			
54.59	31	1340	0.90	1080	70	2	-	-	M1-6			
63.80	27	1370	0.80	1140	70	2	-	-	-			
67.20	25	1450	0.97	1190	130	2	-	-	M1-6			
69.39	24	1370	0.74	1180	70	2	-	-	-			
71.75	24	1480	0.94	1200	130	2	-	-	M1-6			
84.00	20	1480	0.82	1200	130	2	-	-	M1-6			
94.08	18	1480	0.74	1200	130	2	-	-	M1-6			
110.73	15	1480	0.64	1200	140	2	-	-	M1-6			
128.10	13	1480	0.57	1200	140	2	-	-	M1-6			
137.05	12	1480	0.54	1200	140	2	-	-	M1-6			
158.12	11	1490	0.48	1200	140	2	-	-	-			
184.80	9.2	1490	0.42	1200	140	2	-	-	-			
201.00	8.5	1500	0.39	1200	140	2	-	-	-			
4.00	425	420	3.2	450	330	2	-	-	M1-6	S47	AD2	
4.76	357	510	3.3	460	320	2	-	-	M1-6			
5.39	315	580	3.3	460	320	2	-	-	M1-6			
6.40	266	670	3.2	470	310	2	-	-	M1-6			
6.83	249	690	3.1	480	310	2	-	-	M1-6			
7.28	234	760	3.2	480	320	2	-	-	M1-6			
8.64	197	890	3.2	490	310	2	-	-	M1-6			
9.23	184	930	3.1	490	310	2	-	-	M1-6			
10.80	157	960	2.8	520	310	2	-	-	M1-6			
12.10	140	960	2.5	550	320	2	-	-	M1-6			
14.24	119	960	2.1	600	320	2	-	-	M1-6			
16.47	103	960	1.9	640	320	2	-	-	M1-6			
17.62	96	960	1.7	660	320	2	-	-	M1-6			
19.54	87	1090	1.9	730	350	2	-	-	M1-6			
20.33	84	970	1.5	700	190	2	-	-	M1-6			
23.20	73	1260	1.9	750	350	2	-	-	M1-6			
24.77	69	1280	1.8	770	350	2	-	-	M1-6			
29.00	59	1360	1.6	810	290	2	-	-	M1-6			
32.48	52	1370	1.5	850	300	2	-	-	M1-6			
38.23	44	1370	1.3	910	300	2	-	-	M1-6			
44.22	38	1370	1.1	980	310	2	-	-	M1-6			
47.32	36	1370	1.1	1000	310	2	-	-	M1-6			
54.59	31	1370	0.93	1070	320	2	-	-	M1-6			
56.61	30	1350	1.1	1130	380	2	-	-	M1-6			
63.80	27	1370	0.81	1140	320	2	-	-	-			
67.20	25	1450	0.98	1190	370	2	-	-	M1-6			
69.39	24	1370	0.75	1180	320	2	-	-	-			
71.75	24	1480	0.95	1200	380	2	-	-	M1-6			
84.00	20	1480	0.83	1200	380	2	-	-	M1-6			
94.08	18	1480	0.75	1200	380	2	-	-	M1-6			
110.73	15	1480	0.66	1200	380	2	-	-	M1-6			
128.10	13	1480	0.58	1200	380	2	-	-	M1-6			
137.05	12	1480	0.55	1200	380	2	-	-	M1-6			
158.12	11	1490	0.49	1200	380	2	-	-	-			
184.80	9.2	1490	0.43	1200	380	2	-	-	-			
201.00	8.5	1500	0.41	1200	380	2	-	-	-			

Weight [lbs]	Stages		AD1	AD2
	Large	Small		
S47	2	-	25	27

SA47: +3 lbs / SAF47: +6 lbs / SF47: +8 lbs

11.2.3 S57

S57 AD.. , n _e = 1700 rpm										2610 lb-in				
i [ratio]	n _a [rpm]	T _{a max} [lb-in]	P _e [HP]	F _{Ra} ¹⁾ [lb]	F _{Re} [lb]	Stages		φ (/R) [']						
						Lg	Sm							
84.00	20	2430	1.3	1640	80	2	-	-	M1-6	S57	AD1			
94.08	18	2520	1.2	1620	80	2	-	-	M1-6					
110.73	15	2610	1.1	1600	80	2	-	-	M1-6					
128.10	13	2610	0.93	1600	90	2	-	-	M1-6					
137.05	12	2610	0.88	1600	90	2	-	-	M1-6					
158.12	11	2610	0.78	1600	90	2	-	-	M1-6					
184.80	9.2	2610	0.68	1600	90	2	-	-	M1-6					
201.00	8.5	2610	0.64	1600	90	2	-	-	M1-6					
4.00	425	630	4.7	750	290	2	-	-	M1-6			S57	AD2	
4.76	357	740	4.7	770	280	2	-	-	M1-6					
5.39	315	840	4.7	790	280	2	-	-	M1-6					
6.40	266	870	4.1	840	280	2	-	-	M1-6					
6.83	249	890	4.0	860	280	2	-	-	M1-6					
7.28	234	1080	4.5	840	280	2	-	-	M1-6					
8.64	197	1250	4.4	870	270	2	-	-	M1-6					
9.23	184	1320	4.4	880	270	2	-	-	M1-6					
10.80	157	1500	4.3	900	260	2	-	-	M1-6					
12.10	140	1500	3.8	940	270	2	-	-	M1-6					
14.24	119	1500	3.3	1020	270	2	-	-	M1-6					
16.47	103	1490	2.8	1090	280	2	-	-	M1-6					
17.62	96	1490	2.7	1120	280	2	-	-	M1-6					
19.54	87	1620	2.8	1240	330	2	-	-	M1-6					
20.33	84	1490	2.3	1190	280	2	-	-	M1-6					
23.20	73	1860	2.7	1280	320	2	-	-	M1-6					
24.77	69	1950	2.7	1300	320	2	-	-	M1-6					
29.00	59	2170	2.5	1350	320	2	-	-	M1-6					
32.48	52	2170	2.3	1420	320	2	-	-	M1-6					
38.23	44	2170	2.0	1520	320	2	-	-	M1-6					
44.22	38	2170	1.7	1610	330	2	-	-	M1-6					
47.32	36	2170	1.6	1660	200	2	-	-	M1-6					
54.59	31	2170	1.4	1690	210	2	-	-	M1-6					
56.61	30	1990	1.5	1720	360	2	-	-	M1-6					
63.80	27	2170	1.2	1690	220	2	-	-	M1-6					
67.20	25	2300	1.5	1670	340	2	-	-	M1-6					
69.39	24	2170	1.1	1690	220	2	-	-	-					
71.75	24	2430	1.5	1640	330	2	-	-	M1-6					
84.00	20	2520	1.3	1620	330	2	-	-	M1-6					
94.08	18	2660	1.3	1590	330	2	-	-	M1-6					
110.73	15	2610	1.1	1600	330	2	-	-	M1-6					
128.10	13	2610	0.94	1600	340	2	-	-	M1-6					
137.05	12	2610	0.89	1600	340	2	-	-	M1-6					
158.12	11	2610	0.79	1600	350	2	-	-	M1-6					
184.80	9.2	2610	0.69	1600	350	2	-	-	M1-6					
201.00	8.5	2610	0.65	1600	350	2	-	-	-					



Weight [lbs]	Stages		AD1	AD2
	Large	Small		
S57	2	-	33	36

SA57: -1 lbs / SAF57: +6 lbs / SF57: +8 lbs

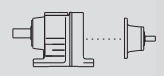

11.2.4 S67

S67 AD.. , n _e = 1700 rpm										4600 lb-in				
i [ratio]	n _a [rpm]	T _a max [lb-in]	P _e [HP]	F _{Ra} ¹⁾ [lb]	F _{Re} [lb]	Stages		φ (/R) [']						
						Lg	Sm							
7.56	225	1950	7.8	870	230	2	-	-	M1-6	S67	AD2			
8.69	196	2120	7.4	900	230	2	-	-	M1-6					
10.03	169	2350	7.1	920	220	2	-	-	M1-6					
11.03	154	2520	7.0	930	210	2	-	-	M1-6					
12.96	131	2790	6.6	940	210	2	-	-	M1-6					
13.73	124	2880	6.4	940	210	2	-	-	M1-6					
15.60	109	3010	5.9	990	200	2	-	-	M1-6					
17.28	98	3010	5.4	1060	210	2	-	-	M1-6					
20.37	83	3010	4.6	1150	220	2	-	-	M1-6					
23.22	73	3010	4.0	1230	230	2	-	-	M1-6					
23.33	73	3580	5.1	1290	280	2	-	-	M1-6					
24.44	70	3010	3.8	1260	230	2	-	-	M1-6					
26.93	63	4030	5.0	1310	280	2	-	-	M1-6					
29.63	57	4250	4.8	1340	270	2	-	-	M1-6					
34.80	49	4250	4.1	1450	280	2	-	-	M1-6					
36.85	46	4250	3.9	1490	280	2	-	-	M1-6					
41.89	41	4250	3.4	1580	290	2	-	-	M1-6					
46.40	37	4250	3.1	1660	290	2	-	-	M1-6					
54.70	31	4250	2.7	1790	290	2	-	-	M1-6					
62.35	27	4250	2.4	1900	300	2	-	-	M1-6					
65.63	26	4250	2.3	1940	300	2	-	-	M1-6					
67.57	25	4380	2.7	2000	340	2	-	-	M1-6					
75.06	23	4250	2.0	2030	300	2	-	-	M1-6					
78.00	22	4510	2.4	1970	340	2	-	-	M1-6					
85.83	20	4600	2.3	1950	340	2	-	-	M1-6					
100.80	17	4600	2.0	1950	350	2	-	-	M1-6					
106.75	16	4600	1.9	1950	350	2	-	-	M1-6					
121.33	14	4600	1.7	1950	290	2	-	-	M1-6					
134.40	13	4600	1.5	1950	290	2	-	-	M1-6					
158.45	11	4600	1.3	1950	290	2	-	-	M1-6					
180.60	9.4	4600	1.2	1950	300	2	-	-	M1-6					
190.11	8.9	4600	1.1	1950	300	2	-	-	M1-6					
217.41	7.8	4600	1.0	1950	300	2	-	-	-					
7.56	225	2210	8.9	810	430	2	-	-	M1-6			S67	AD3	
8.69	196	2480	8.7	770	420	2	-	-	M1-6					
10.03	169	2790	8.5	720	410	2	-	-	M1-6					
11.03	154	3010	8.3	680	400	2	-	-	M1-6					
12.96	131	3010	7.1	820	410	2	-	-	M1-6					
13.73	124	3010	6.7	870	410	2	-	-	M1-6					
15.60	109	3010	5.9	990	420	2	-	-	M1-6					
17.28	98	3010	5.4	1060	420	2	-	-	M1-6					
20.30	84	3190	5.2	1270	500	2	-	-	M1-6					
20.37	83	3010	4.6	1150	430	2	-	-	M1-6					
23.33	73	3580	5.1	1290	500	2	-	-	M1-6					
26.93	63	4030	5.0	1310	490	2	-	-	M1-6					
29.63	57	4250	4.8	1340	490	2	-	-	M1-6					
34.80	49	4250	4.1	1450	500	2	-	-	M1-6					
36.85	46	4250	3.9	1490	500	2	-	-	M1-6					
41.89	41	4250	3.5	1580	500	2	-	-	M1-6					
46.40	37	4250	3.2	1660	500	2	-	-	M1-6					
54.70	31	4250	2.7	1790	510	2	-	-	M1-6					
58.80	29	4070	2.9	1950	550	2	-	-	M1-6					
67.57	25	4380	2.7	2000	550	2	-	-	M1-6					
78.00	22	4510	2.4	1970	550	2	-	-	M1-6					
85.83	20	4600	2.3	1950	560	2	-	-	M1-6					
100.80	17	4600	2.0	1950	560	2	-	-	M1-6					
106.75	16	4600	1.9	1950	560	2	-	-	M1-6					
121.33	14	4600	1.7	1950	560	2	-	-	M1-6					
134.40	13	4600	1.5	1950	560	2	-	-	M1-6					
158.45	11	4600	1.3	1950	560	2	-	-	M1-6					
Weight [lbs]		Stages		AD2		AD3								
		Large	Small											
S67		2	-	60		67								
SA67: +2 lbs / SAF67: +12 lbs / SF67: +14 lbs														

11.2.5 S67R37

S67R37 AD.. , n _e = 1700 rpm										5040 lb-in		
i [ratio]	n _a [rpm]	T _{a max} [lb-in]	P _e [HP]	F _{Ra} ¹⁾ [lb]	F _{Re} [lb]	Stages		φ _(/R) [']				
						Lg	Sm					
156	11	4560	1.1	1960	70	2	2	-	-			
168	10	5040	1.1	1840	80	2	2	-	-			
198	8.6	5040	0.98	1840	90	2	2	-	-			
221	7.7	5040	0.90	1840	130	2	2	-	-			
246	6.9	5040	0.81	1840	110	2	2	-	-			
281	6.0	5040	0.73	1840	150	2	2	-	-			
319	5.3	5040	0.65	1840	140	2	2	-	-			
365	4.7	5040	0.57	1840	140	2	2	-	-			
424	4.0	5040	0.51	1840	160	2	2	-	-			
469	3.6	5040	0.47	1840	160	2	2	-	-			
543	3.1	5040	0.41	1840	160	2	2	-	-			
615	2.8	5040	0.37	1840	160	2	2	-	-			
712	2.4	5040	0.32	1840	160	2	2	-	-			
809	2.1	5040	0.28	1840	160	2	2	-	-			
914	1.9	5040	0.26	1840	160	2	3	-	-			
1045	1.6	5040	0.23	1840	170	2	3	-	-			
1194	1.4	5040	0.22	1840	170	2	3	-	-			
1363	1.2	5040	0.19	1840	170	2	3	-	-			
1559	1.1	5040	0.17	1840	170	2	3	-	-			
1772	0.96	5040	0.15	1840	170	2	3	-	-		S67R37	AD1
2014	0.84	5040	0.14	1840	170	2	3	-	-			
2279	0.75	5040	0.13	1840	170	2	3	-	-			
2630	0.65	5040	0.12	1840	170	2	3	-	-			
2944	0.58	5040	0.11	1840	170	2	3	-	-			
3432	0.50	5040	0.10	1840	170	2	3	-	-			
3880	0.44	5040	0.09	1840	170	2	3	-	-			
4410	0.39	5040	0.08	1840	170	2	3	-	-			
4965	0.34	5040	0.08	1840	170	2	3	-	-			
5759	0.30	5040	0.07	1840	170	2	3	-	-			
6531	0.26	5040	0.09	1840	170	2	3	-	-			
7455	0.23	5040	0.08	1840	170	2	3	-	-			
8529	0.20	5040	0.07	1840	170	2	3	-	-			
9694	0.18	5040	0.08	1840	170	2	3	-	-			
11013	0.15	5040	0.06	1840	170	2	3	-	-			
12774	0.13	5040	0.06	1840	170	2	3	-	-			
14383	0.12	5040	0.06	1840	170	2	3	-	-			
16682	0.10	5040	0.05	1840	170	2	3	-	-			
18120	0.09	5040	0.05	1840	170	2	3	-	-			
19594	0.09	5040	0.05	1840	170	2	3	-	-			
21362	0.08	5040	0.05	1840	170	2	3	-	-			
156	11	5040	1.2	1840	300	2	2	-	-			
168	10	5040	1.2	1840	340	2	2	-	-			
198	8.6	5040	0.99	1840	340	2	2	-	-			
221	7.7	5040	0.92	1840	380	2	2	-	-			
246	6.9	5040	0.82	1840	370	2	2	-	-			
281	6.0	5040	0.75	1840	380	2	2	-	-			
319	5.3	5040	0.66	1840	380	2	2	-	-			
365	4.7	5040	0.59	1840	380	2	2	-	-			
424	4.0	5040	0.53	1840	390	2	2	-	-		S67R37	AD2
469	3.6	5040	0.49	1840	390	2	2	-	-			
543	3.1	5040	0.42	1840	390	2	2	-	-			
615	2.8	5040	0.38	1840	390	2	2	-	-			
712	2.4	5040	0.33	1840	390	2	2	-	-			
809	2.1	5040	0.30	1840	390	2	2	-	-			
914	1.9	5040	0.28	1840	390	2	3	-	-			
1045	1.6	5040	0.25	1840	390	2	3	-	-			
1194	1.4	5040	0.23	1840	400	2	3	-	-			



S67R37 AD.. , n_e = 1700 rpm 5040 lb-in

i [ratio]	n _a [rpm]	T _{a max} [lb-in]	P _e [HP]	F _{Ra} ¹⁾ [lb]	F _{Re} [lb]	Stages		φ _(/R) [']		
						Lg	Sm			
1363	1.2	5040	0.20	1840	400	2	3	-	-	S67R37 AD2
1559	1.1	5040	0.18	1840	400	2	3	-	-	
1772	0.96	5040	0.17	1840	400	2	3	-	-	
2014	0.84	5040	0.15	1840	400	2	3	-	-	
2279	0.75	5040	0.14	1840	400	2	3	-	-	
2630	0.65	5040	0.13	1840	400	2	3	-	-	
2944	0.58	5040	0.12	1840	400	2	3	-	-	
3432	0.50	5040	0.12	1840	400	2	3	-	-	
3880	0.44	5040	0.10	1840	400	2	3	-	-	
4410	0.39	5040	0.10	1840	400	2	3	-	-	
4965	0.34	5040	0.09	1840	400	2	3	-	-	
5759	0.30	5040	0.09	1840	400	2	3	-	-	
6531	0.26	5040	0.10	1840	400	2	3	-	-	
7455	0.23	5040	0.09	1840	400	2	3	-	-	
8529	0.20	5040	0.09	1840	400	2	3	-	-	
9694	0.18	5040	0.09	1840	400	2	3	-	-	
11013	0.15	5040	0.08	1840	400	2	3	-	-	
12774	0.13	5040	0.07	1840	400	2	3	-	-	
14383	0.12	5040	0.07	1840	400	2	3	-	-	
16682	0.10	5040	0.07	1840	400	2	3	-	-	
18120	0.09	5040	0.07	1840	400	2	3	-	-	
19594	0.09	5040	0.06	1840	400	2	3	-	-	
21362	0.08	5040	0.06	1840	400	2	3	-	-	



Weight [lbs]	Stages		AD1	AD2
	Large	Small		
S67R37	2	2	81	83
	2	3	82	84
SA67: +2 lbs / SAF67: +12 lbs / SF67: +14 lbs				

11

11.2.6 S77

S77 AD.. , n _e = 1700 rpm										11240 lb-in		
i [ratio]	n _a [rpm]	T _a max [lb-in]	P _e [HP]	F _{Ra} ¹⁾ [lb]	F _{Re} [lb]	Stages		φ (/R) [']				
						Lg	Sm					
41.07	41	8670	6.8	1910	210	2	-	-	M1-6	S77	AD2	
43.33	39	8940	6.6	1930	210	2	-	-	M1-6			
49.38	34	9560	6.2	1990	200	2	-	-	M1-6			
53.87	32	9740	5.8	2060	200	2	-	-	M1-6			
56.92	30	8140	5.4	2460	300	2	-	-	M1-6			
63.03	27	9740	5.0	2240	210	2	-	-	M1-6			
66.67	25	8580	4.9	2600	310	2	-	-	M1-6			
71.33	24	9740	4.5	2380	220	2	-	-	M1-6			
75.09	23	9740	4.3	2440	220	2	-	-	M1-6			
75.20	23	8940	4.6	2700	310	2	-	-	M1-6			
85.22	20	9290	4.2	2820	310	2	-	-	M1-6			
97.14	18	9650	3.9	2950	310	2	-	-	M1-6			
107.83	16	9820	3.6	2930	310	2	-	-	M1-6			
123.20	14	10180	3.3	2860	310	2	-	-	M1-6			
130.00	13	10350	3.2	2830	310	2	-	-	M1-6			
148.15	11	10620	2.9	2770	310	2	-	-	M1-6			
161.60	11	10800	2.7	2730	310	2	-	-	M1-6			
189.09	9.0	10970	2.4	2690	310	2	-	-	M1-6			
214.00	7.9	11240	2.2	2630	310	2	-	-	M1-6			
225.26	7.5	11240	2.1	2630	310	2	-	-	M1-6			
256.47	6.6	11240	1.9	2630	310	2	-	-	M1-6			
15.28	111	6280	12.3	550	310	2	-	-	M1-6	S77	AD3	
17.45	97	6280	10.9	720	320	2	-	-	M1-6			
18.42	92	6280	10.3	790	320	2	-	-	M1-6			
18.97	90	7610	12.6	1370	400	2	-	-	M1-6			
20.99	81	6240	9.0	990	330	2	-	-	M1-6			
22.22	77	8140	11.5	1430	400	2	-	-	M1-6			
22.89	74	6240	8.3	1110	340	2	-	-	M1-6			
25.07	68	8500	10.7	1480	400	2	-	-	M1-6			
28.41	60	8760	9.8	1560	400	2	-	-	M1-6			
32.38	53	9200	9.0	1620	400	2	-	-	M1-6			
35.94	47	9380	8.3	1700	410	2	-	-	M1-6			
41.07	41	9740	7.6	1780	410	2	-	-	M1-6			
43.33	39	9740	7.2	1830	410	2	-	-	M1-6			
49.38	34	9740	6.4	1970	420	2	-	-	M1-6			
53.87	32	9740	5.9	2060	420	2	-	-	M1-6			
56.92	30	8140	5.5	2460	520	2	-	-	M1-6			
63.03	27	9740	5.1	2240	420	2	-	-	M1-6			
66.67	25	8580	5.0	2600	520	2	-	-	M1-6			
75.20	23	8940	4.6	2700	520	2	-	-	M1-6			
85.22	20	9290	4.3	2820	520	2	-	-	M1-6			
97.14	18	9650	3.9	2950	520	2	-	-	M1-6			
107.83	16	9820	3.6	2930	520	2	-	-	M1-6			
123.20	14	10180	3.3	2860	520	2	-	-	M1-6			
130.00	13	10350	3.2	2830	520	2	-	-	M1-6			
148.15	11	10620	2.9	2770	520	2	-	-	M1-6			
161.60	11	10800	2.8	2730	520	2	-	-	M1-6			
189.09	9.0	10970	2.4	2690	520	2	-	-	M1-6			
8.06	211	5090	18.8	370	710	2	-	-	M1-6	S77	AD4	
9.44	180	5800	18.3	210	690	2	-	-	M1-6			
10.65	160	6420	18.0	70	680	2	-	-	M1-6			
12.07	141	6420	15.9	210	690	2	-	-	M1-6			
13.76	124	6370	13.9	380	700	2	-	-	M1-6			
15.28	111	6370	12.6	510	720	2	-	-	M1-6			
17.45	97	6280	10.9	720	730	2	-	-	M1-6			
18.42	92	6280	10.4	790	740	2	-	-	M1-6			



S77 AD.. , $n_e = 1700$ rpm 11240 lb-in

i [ratio]	n_a [rpm]	T_a max [lb-in]	P_e [HP]	$F_{Ra}^{1)}$ [lb]	F_{Re} [lb]	Stages		ϕ (/R) [']		
						Lg	Sm			
18.97	90	7610	12.6	1370	800	2	-	-	M1-6	S77 AD4
22.22	77	8140	11.6	1430	800	2	-	-	M1-6	
25.07	68	8500	10.7	1480	800	2	-	-	M1-6	
28.41	60	8760	9.8	1560	800	2	-	-	M1-6	
32.38	53	9200	9.1	1620	800	2	-	-	M1-6	
35.94	47	9380	8.4	1700	810	2	-	-	M1-6	
41.07	41	9740	7.7	1780	810	2	-	-	M1-6	
43.33	39	9740	7.3	1830	810	2	-	-	M1-6	
56.92	30	8140	5.5	2460	910	2	-	-	M1-6	
66.67	25	8580	5.0	2600	910	2	-	-	M1-6	
75.20	23	8940	4.7	2700	910	2	-	-	M1-6	
85.22	20	9290	4.3	2820	910	2	-	-	M1-6	
97.14	18	9650	4.0	2950	910	2	-	-	M1-6	
107.83	16	9820	3.7	2930	910	2	-	-	M1-6	
123.20	14	10180	3.4	2860	910	2	-	-	M1-6	
130.00	13	10350	3.3	2830	910	2	-	-	M1-6	



Weight [lbs]	Stages		AD2	AD3	AD4
	Large	Small			
S77	2	-	104	111	125

SA77: -1.0 lbs / SAF77: +14 lbs / SF77: +21 lbs

11.2.7 S77R37

S77R37 AD.. , n _e = 1700 rpm										11240 lb-in		
i [ratio]	n _a [rpm]	T _a max [lb-in]	P _e [HP]	F _{Ra} ¹⁾ [lb]	F _{Re} [lb]	Stages		φ _(/R) [']				
						Lg	Sm					
327	5.2	10970	1.2	2690	110	2	2	-	-			
389	4.4	10970	1.1	2690	120	2	2	-	-			
438	3.9	10970	0.95	2690	120	2	2	-	-			
499	3.4	10970	0.84	2690	130	2	2	-	-			
574	3.0	10970	0.74	2690	130	2	2	-	-			
637	2.7	10970	0.67	2690	140	2	2	-	-			
714	2.4	10970	0.60	2690	150	2	2	-	-			
837	2.0	10970	0.51	2690	140	2	2	-	-			
954	1.8	10970	0.45	2690	150	2	2	-	-			
1100	1.5	10970	0.40	2690	150	2	2	-	-			
1245	1.4	10970	0.37	2690	160	2	3	-	-			
1404	1.2	10970	0.33	2690	160	2	3	-	-			
1600	1.1	10970	0.30	2690	160	2	3	-	-			
1745	0.97	10970	0.28	2690	170	2	3	-	-			
1813	0.94	10970	0.27	2690	160	2	3	-	-			
2083	0.82	10970	0.23	2690	160	2	3	-	-			
2374	0.72	10970	0.21	2690	170	2	3	-	-			
2753	0.62	10970	0.18	2690	170	2	3	-	-			
3098	0.55	11240	0.23	2630	170	2	3	-	-			
3540	0.48	11240	0.21	2630	170	2	3	-	-			
3992	0.43	11240	0.19	2630	170	2	3	-	-			
4618	0.37	11240	0.18	2630	170	2	3	-	-			
5214	0.33	11240	0.15	2630	170	2	3	-	-			
5943	0.29	11240	0.14	2630	170	2	3	-	-			
6735	0.25	11240	0.13	2630	170	2	3	-	-			
7735	0.22	11240	0.11	2630	170	2	3	-	-			
8817	0.19	11240	0.10	2630	170	2	3	-	-			
9887	0.17	11240	0.10	2630	170	2	3	-	-			
11569	0.15	11240	0.10	2630	170	2	3	-	-			
13110	0.13	11240	0.09	2630	170	2	3	-	-			
14668	0.12	11240	0.08	2630	170	2	3	-	-			
17013	0.10	11240	0.07	2630	170	2	3	-	-			
19907	0.09	11240	0.07	2630	170	2	3	-	-			
21787	0.08	11240	0.06	2630	170	2	3	-	-			
25493	0.07	11240	0.06	2630	170	2	3	-	-			
219	7.8	10970	1.8	2690	340	2	2	-	-			
250	6.8	10970	1.6	2690	350	2	2	-	-			
289	5.9	10970	1.4	2690	280	2	2	-	-			
327	5.2	10970	1.3	2690	370	2	2	-	-			
389	4.4	10970	1.1	2690	370	2	2	-	-			
438	3.9	10970	0.96	2690	370	2	2	-	-			
499	3.4	10970	0.86	2690	380	2	2	-	-			
574	3.0	10970	0.75	2690	380	2	2	-	-			
637	2.7	10970	0.68	2690	380	2	2	-	-			
714	2.4	10970	0.61	2690	380	2	2	-	-			
837	2.0	10970	0.53	2690	380	2	2	-	-			
954	1.8	10970	0.47	2690	380	2	2	-	-			
1100	1.5	10970	0.41	2690	380	2	2	-	-			
1245	1.4	10970	0.38	2690	390	2	3	-	-			
1404	1.2	10970	0.35	2690	390	2	3	-	-			
1600	1.1	10970	0.31	2690	390	2	3	-	-			
1745	0.97	10970	0.29	2690	390	2	3	-	-			
1813	0.94	10970	0.28	2690	390	2	3	-	-			
2083	0.82	10970	0.25	2690	390	2	3	-	-			
2374	0.72	10970	0.22	2690	390	2	3	-	-			
2753	0.62	10970	0.20	2690	390	2	3	-	-			



S77R37 AD.. , n_e = 1700 rpm 11240 lb-in

i [ratio]	n _a [rpm]	T _{a max} [lb-in]	P _e [HP]	F _{Ra} ¹⁾ [lb]	F _{Re} [lb]	Stages		φ (°/R) [']			
						Lg	Sm				
3098	0.55	11240	0.24	2630	400	2	3	-	-	S77R37	AD2
3540	0.48	11240	0.22	2630	400	2	3	-	-		
3992	0.43	11240	0.20	2630	400	2	3	-	-		
4618	0.37	11240	0.19	2630	400	2	3	-	-		
5214	0.33	11240	0.17	2630	400	2	3	-	-		
5943	0.29	11240	0.15	2630	400	2	3	-	-		
6735	0.25	11240	0.14	2630	400	2	3	-	-		
7735	0.22	11240	0.13	2630	400	2	3	-	-		
8817	0.19	11240	0.12	2630	400	2	3	-	-		
9887	0.17	11240	0.12	2630	400	2	3	-	-		
11569	0.15	11240	0.11	2630	400	2	3	-	-		
13110	0.13	11240	0.10	2630	400	2	3	-	-		
14668	0.12	11240	0.09	2630	400	2	3	-	-		
17013	0.10	11240	0.08	2630	400	2	3	-	-		
19907	0.09	11240	0.08	2630	400	2	3	-	-		
21787	0.08	11240	0.08	2630	400	2	3	-	-		
25493	0.07	11240	0.07	2630	400	2	3	-	-		



Weight [lbs]	Stages		AD1	AD2
	Large	Small		
S77R37	2	2	124	126
	2	3	125	127

SA77: -1.0 lbs / SAF77: +14 lbs / SF77: +21 lbs

11.2.8 S87



S87 AD.. , n _e = 1700 rpm										20180 lb-in		
i [ratio]	n _a [rpm]	T _{a max} [lb-in]	P _e [HP]	F _{Ra} ¹⁾ [lb]	F _{Re} [lb]	Stages		φ (/R) [']				
						Lg	Sm					
57.00	30	12120	6.8	6590	210	2	-	-	M1-6	S87	AD2	
64.27	26	12830	6.4	6570	200	2	-	-	M1-6			
70.43	24	13450	6.1	6550	200	2	-	-	M1-6			
77.14	22	15050	7.2	6500	280	2	-	-	M1-6			
81.76	21	14160	5.6	6520	190	2	-	-	M2			
86.15	20	15660	6.8	6480	280	2	-	-	M1-6			
91.20	19	13450	4.8	6550	210	2	-	-	-			
99.26	17	16280	6.2	6450	280	2	-	-	M1-6			
110.40	15	16820	5.8	6430	280	2	-	-	M1-6			
123.48	14	17350	5.3	6410	290	2	-	-	M1-6			
139.05	12	17880	4.9	6390	290	2	-	-	M1-6			
151.30	11	18230	4.6	6370	290	2	-	-	M1-6			
180.00	9.4	18850	4.1	6340	290	2	-	-	M1-6			
202.96	8.4	19380	3.8	6320	290	2	-	-	M1-6			
222.40	7.6	19560	3.5	6310	290	2	-	-	M1-6			
258.18	6.6	20000	3.1	6290	290	2	-	-	M1-6			
288.00	5.9	20180	2.8	6280	290	2	-	-	M1-6			
27.28	62	13280	15.1	5260	340	2	-	-	M1-6	S87	AD3	
31.43	54	14160	14.0	5460	340	2	-	-	M1-6			
34.96	49	14160	12.6	5680	350	2	-	-	M1-6			
39.10	43	14160	11.3	5920	360	2	-	-	M1-6			
44.03	39	14160	10.1	6180	370	2	-	-	M1-6			
47.91	35	14160	9.3	6370	370	2	-	-	M1-6			
57.00	30	14160	7.9	6520	380	2	-	-	M1-6			
64.00	27	13980	8.1	6530	480	2	-	-	M1-6			
64.27	26	14160	7.0	6520	380	2	-	-	M1-6			
70.43	24	14160	6.5	6520	390	2	-	-	M1-6			
77.14	22	15050	7.3	6500	480	2	-	-	M1-6			
81.76	21	14160	5.6	6520	390	2	-	-	M2			
86.15	20	15660	6.8	6480	480	2	-	-	M1-6			
99.26	17	16280	6.2	6450	480	2	-	-	M1-6			
110.40	15	16820	5.8	6430	480	2	-	-	M1-6			
123.48	14	17350	5.4	6410	480	2	-	-	M1-6			
139.05	12	17880	5.0	6390	480	2	-	-	M1-6			
151.30	11	18230	4.7	6370	480	2	-	-	M1-6			
180.00	9.4	18850	4.1	6340	480	2	-	-	M1-6			
202.96	8.4	19380	3.8	6320	480	2	-	-	M1-6			
222.40	7.6	19560	3.5	6310	480	2	-	-	M1-6			
258.18	6.6	20000	3.1	6290	480	2	-	-	M1-6			
7.88	216	7350	28	3540	670	2	-	-	M1-6	S87	AD4	
9.07	187	8410	27	3590	640	2	-	-	M1-6			
10.93	156	10000	27	3630	620	2	-	-	M1-6			
12.21	139	10970	27	3480	600	2	-	-	M1-6			
14.06	121	10970	23	3820	620	2	-	-	M1-6			
15.64	109	10970	21	4080	630	2	-	-	M1-6			
17.49	97	10970	18.7	4270	640	2	-	-	M1-6			
19.70	86	10970	16.7	4470	660	2	-	-	M1-6			
20.27	84	12570	19.2	4770	750	2	-	-	M1-6			
21.43	79	10970	15.3	4620	670	2	-	-	M1-6			
24.43	70	14160	17.9	4960	740	2	-	-	M1-6			
25.50	67	10970	13.0	4940	680	2	-	-	M1-6			
27.28	62	14160	16.1	5180	750	2	-	-	M1-6			
31.43	54	14160	14.1	5460	760	2	-	-	M1-6			
34.96	49	14160	12.7	5680	770	2	-	-	M1-6			
39.10	43	14160	11.4	5920	780	2	-	-	M1-6			
44.03	39	14160	10.2	6180	790	2	-	-	M1-6			
47.91	35	14160	9.4	6370	790	2	-	-	M1-6			

S87 AD.. , n_e = 1700 rpm **20180 lb-in**



i [ratio]	n _a [rpm]	T _{a max} [lb-in]	P _e [HP]	F _{Ra} ¹⁾ [lb]	F _{Re} [lb]	Stages		φ (°/R) [']			
						Lg	Sm				
57.00	30	14160	7.9	6520	800	2	-	-	M1-6	S87	AD4
64.00	27	13980	8.1	6530	890	2	-	-	M1-6		
77.14	22	15050	7.3	6500	890	2	-	-	M1-6		
86.15	20	15660	6.9	6480	890	2	-	-	M1-6		
99.26	17	16280	6.2	6450	890	2	-	-	M1-6		
110.40	15	16820	5.8	6430	890	2	-	-	M1-6		
123.48	14	17350	5.4	6410	890	2	-	-	M1-6		
139.05	12	17880	5.0	6390	890	2	-	-	M1-6		
151.30	11	18230	4.7	6370	890	2	-	-	M1-6		
180.00	9.4	18850	4.2	6340	890	2	-	-	M1-6		
7.88	216	7350	28	3540	1340	2	-	-	M1-6	S87	AD5
9.07	187	8410	27	3590	1320	2	-	-	M1-6		
10.93	156	10000	27	3630	1290	2	-	-	M1-6		
12.21	139	10970	27	3480	1270	2	-	-	M1-6		
14.06	121	10970	23	3820	1290	2	-	-	M1-6		
15.64	109	10970	21	4080	1300	2	-	-	M1-6		
17.49	97	10970	18.8	4270	1310	2	-	-	M1-6		
19.70	86	10970	16.7	4470	1320	2	-	-	M1-6		
20.27	84	12570	19.2	4770	1420	2	-	-	M1-6		
24.43	70	14160	18.0	4960	1410	2	-	-	M1-6		
27.28	62	14160	16.2	5180	1420	2	-	-	M1-6		
31.43	54	14160	14.1	5460	1430	2	-	-	M1-6		
34.96	49	14160	12.7	5680	1440	2	-	-	M1-6		
39.10	43	14160	11.5	5920	1440	2	-	-	M1-6		
44.03	39	14160	10.2	6180	1450	2	-	-	M1-6		
64.00	27	13980	8.2	6530	1550	2	-	-	M1-6		
77.14	22	15050	7.4	6500	1550	2	-	-	M1-6		
86.15	20	15660	6.9	6480	1550	2	-	-	M1-6		
99.26	17	16280	6.3	6450	1550	2	-	-	M1-6		
110.40	15	16820	5.9	6430	1550	2	-	-	M1-6		
123.48	14	17350	5.5	6410	1550	2	-	-	M1-6		
139.05	12	17880	5.1	6390	1550	2	-	-	M1-6		

Weight [lbs]	Stages		AD2	AD3	AD4	AD5
	Large	Small				
S87	2	-	183	192	205	238
SA87: -5.0 lbs / SAF87: +30 lbs / SF87: +48 lbs						

11.2.9 S87R57

S87R57 AD.. , n _e = 1700 rpm										22130 lb-in		
i [ratio]	n _a [rpm]	T _a max [lb-in]	P _e [HP]	F _{Ra} ¹⁾ [lb]	F _{Re} [lb]	Stages		φ _(/R) [']				
						Lg	Sm					
205	8.3	17520	2.9	6390	320	2	2	-	-			
222	7.7	17520	2.7	6390	340	2	2	-	-			
255	6.7	17520	2.4	6390	350	2	2	-	-			
281	6.0	21240	3.0	6230	340	2	2	-	-			
323	5.3	21240	2.7	6230	340	2	2	-	-			
378	4.5	21680	2.4	6210	350	2	2	-	-			
435	3.9	21680	2.1	6210	350	2	2	-	-			
485	3.5	22130	2.0	6180	360	2	2	-	-			
558	3.0	22130	1.7	6180	360	2	2	-	-			
624	2.7	22130	1.6	6180	370	2	2	-	-			
719	2.4	22130	1.4	6180	370	2	2	-	-			
831	2.0	22130	1.2	6180	370	2	2	-	-			
930	1.8	22130	1.1	6180	370	2	2	-	-			
1032	1.6	22130	1.0	6180	380	2	2	-	-			
1191	1.4	22130	0.92	6180	380	2	2	-	-			
1332	1.3	22130	0.84	6180	380	2	2	-	-			
1631	1.0	22130	0.70	6180	380	2	2	-	-			
1824	0.93	22130	0.64	6180	380	2	2	-	-			
2054	0.83	22130	0.58	6180	390	2	2	-	-			
2335	0.73	22130	0.51	6180	390	2	2	-	-		S87R57	AD2
2586	0.66	22130	0.47	6180	390	2	2	-	-			
2905	0.59	22130	0.41	6180	390	2	2	-	-			
3475	0.49	22130	0.36	6180	390	2	2	-	-			
3872	0.44	22130	0.35	6180	390	2	3	-	-			
4606	0.37	22130	0.30	6180	390	2	3	-	-			
5187	0.33	22130	0.28	6180	390	2	3	-	-			
5875	0.29	22130	0.24	6180	390	2	3	-	-			
6706	0.25	22130	0.22	6180	400	2	3	-	-			
7643	0.22	22130	0.19	6180	390	2	3	-	-			
8549	0.20	22130	0.18	6180	400	2	3	-	-			
9904	0.17	22130	0.17	6180	400	2	3	-	-			
11200	0.15	22130	0.16	6180	400	2	3	-	-			
13160	0.13	22130	0.14	6180	400	2	3	-	-			
14820	0.11	22130	0.13	6180	400	2	3	-	-			
16774	0.10	22130	0.12	6180	400	2	3	-	-			
18265	0.09	22130	0.11	6180	400	2	3	-	-			
20568	0.08	22130	0.11	6180	400	2	3	-	-			
23940	0.07	22130	0.10	6180	400	2	3	-	-			
25987	0.07	22130	0.10	6180	400	2	3	-	-			
205	8.3	17520	2.9	6390	530	2	2	-	-			
222	7.7	17520	2.8	6390	550	2	2	-	-			
255	6.7	17520	2.4	6390	560	2	2	-	-			
281	6.0	21240	3.1	6230	550	2	2	-	-			
323	5.3	21240	2.7	6230	550	2	2	-	-			
378	4.5	21680	2.4	6210	560	2	2	-	-			
435	3.9	21680	2.2	6210	570	2	2	-	-			
485	3.5	22130	2.0	6180	570	2	2	-	-			
558	3.0	22130	1.8	6180	580	2	2	-	-		S87R57	AD3
624	2.7	22130	1.6	6180	580	2	2	-	-			
719	2.4	22130	1.4	6180	580	2	2	-	-			
831	2.0	22130	1.3	6180	580	2	2	-	-			
930	1.8	22130	1.2	6180	580	2	2	-	-			
1032	1.6	22130	1.1	6180	590	2	2	-	-			
1191	1.4	22130	0.95	6180	590	2	2	-	-			
1332	1.3	22130	0.87	6180	590	2	2	-	-			
1631	1.0	22130	0.73	6180	590	2	2	-	-			



S87R57 AD.. , $n_e = 1700$ rpm 22130 lb-in

i [ratio]	n_a [rpm]	T_a max [lb-in]	P_e [HP]	$F_{Ra}^{1)}$ [lb]	F_{Re} [lb]	Stages		ϕ (°/R) [']		
						Lg	Sm			
1824	0.93	22130	0.67	6180	600	2	2	-	-	S87R57 AD3
2054	0.83	22130	0.61	6180	600	2	2	-	-	
2335	0.73	22130	0.54	6180	600	2	2	-	-	
2586	0.66	22130	0.50	6180	600	2	2	-	-	
3872	0.44	22130	0.38	6180	600	2	3	-	-	
4606	0.37	22130	0.33	6180	610	2	3	-	-	
5187	0.33	22130	0.31	6180	610	2	3	-	-	
6706	0.25	22130	0.25	6180	610	2	3	-	-	
9904	0.17	22130	0.20	6180	610	2	3	-	-	
11200	0.15	22130	0.19	6180	610	2	3	-	-	
13160	0.13	22130	0.17	6180	610	2	3	-	-	
14820	0.11	22130	0.16	6180	610	2	3	-	-	



Weight [lbs]	Stages		AD2	AD3
	Large	Small		
S87R57	2	2	234	241
	2	3	236	243

SA87: -5.0 lbs / SAF87: +30 lbs / SF87: +48 lbs

11.2.10 S97

S97 AD.. , n _e = 1700 rpm										35400 lb-in		
i [ratio]	n _a [rpm]	T _{a max} [lb-in]	P _e [HP]	F _{Ra} ¹⁾ [lb]	F _{Re} [lb]	Stages		φ (/R) [']				
						Lg	Sm					
65.45	26	23450	12.9	7970	430	2	-	-	M1-6	S97	AD3	
71.43	24	25580	11.2	7890	280	2	-	-	M1-6			
78.26	22	25400	11.8	7900	430	2	-	-	M1-6			
80.85	21	26640	10.3	7850	270	2	-	-	M1-6			
89.60	19	26730	10.8	7850	430	2	-	-	M1-6			
105.71	16	28410	9.8	7790	430	2	-	-	M1-6			
116.92	15	29560	9.3	7740	430	2	-	-	M1-6			
131.85	13	30440	8.5	7700	430	2	-	-	M1-6			
145.60	12	31420	8.0	7660	430	2	-	-	M1-6			
161.74	11	32300	7.5	7620	430	2	-	-	M1-6			
180.95	9.4	33360	6.9	7570	430	2	-	-	M1-6			
196.52	8.7	33980	6.5	7540	430	2	-	-	M1-6			
231.67	7.3	35050	5.8	7480	430	2	-	-	M1-6			
262.22	6.5	35400	5.2	7460	430	2	-	-	M1-6			
286.40	5.9	35400	4.8	7460	440	2	-	-	M1-6			
32.60	52	26370	25	6500	640	2	-	-	M1-6	S97	AD4	
36.05	47	27520	23	6670	640	2	-	-	M1-6			
40.65	42	28590	22	6910	640	2	-	-	M1-6			
44.89	38	29210	20	7140	640	2	-	-	M1-6			
49.87	34	29210	18.1	7440	650	2	-	-	M1-6			
55.79	30	29210	16.2	7750	660	2	-	-	M1-6			
60.59	28	29210	15.0	7750	670	2	-	-	M1-6			
65.45	26	23450	13.0	7970	850	2	-	-	M1-6			
71.43	24	29210	12.8	7750	680	2	-	-	M1-6			
78.26	22	25400	11.8	7900	850	2	-	-	M1-6			
89.60	19	26730	10.9	7850	850	2	-	-	M1-6			
105.71	16	28410	9.9	7790	850	2	-	-	M1-6			
116.92	15	29560	9.3	7740	850	2	-	-	M1-6			
131.85	13	30440	8.6	7700	850	2	-	-	M1-6			
145.60	12	31420	8.1	7660	850	2	-	-	M1-6			
161.74	11	32300	7.5	7620	850	2	-	-	M1-6			
180.95	9.4	33360	7.0	7570	850	2	-	-	M1-6			
196.52	8.7	33980	6.6	7540	850	2	-	-	M1-6			
231.67	7.3	35050	5.8	7480	850	2	-	-	M1-6			
8.26	206	12740	45	4290	1220	2	-	-	M1-6	S97	AD5	
9.55	178	14780	45	4310	1180	2	-	-	M1-6			
11.41	149	17700	45	4160	1140	2	-	-	M1-6			
13.07	130	19200	43	4070	1120	2	-	-	M1-6			
15.42	110	20360	39	4210	1120	2	-	-	M1-6			
17.05	100	21240	37	4250	1120	2	-	-	M1-6			
19.23	88	22130	34	4360	1110	2	-	-	M1-6			
21.23	80	22740	32	4500	1110	2	-	-	M1-6			
23.59	72	23010	29	4790	1120	2	-	-	M1-6			
24.13	70	23630	30	5980	1310	2	-	-	M1-6			
26.39	64	23010	26	5200	1140	2	-	-	M1-6			
27.63	62	24870	27	6200	1310	2	-	-	M1-6			
32.60	52	26370	25	6500	1310	2	-	-	M1-6			
36.05	47	27520	23	6670	1310	2	-	-	M1-6			
40.65	42	28590	22	6910	1310	2	-	-	M1-6			
44.89	38	29210	20	7140	1310	2	-	-	M1-6			
49.87	34	29210	18.1	7440	1320	2	-	-	M1-6			
55.79	30	29210	16.3	7750	1330	2	-	-	M1-6			
65.45	26	23450	13.0	7970	1520	2	-	-	M1-6			
78.26	22	25400	11.8	7900	1520	2	-	-	M1-6			
89.60	19	26730	10.9	7850	1520	2	-	-	M1-6			
105.71	16	28410	9.9	7790	1520	2	-	-	M1-6			
116.92	15	29560	9.4	7740	1520	2	-	-	M1-6			



S97 AD.. , n_e = 1700 rpm 35400 lb-in

i [ratio]	n _a [rpm]	T _{a max} [lb-in]	P _e [HP]	F _{Ra} ¹⁾ [lb]	F _{Re} [lb]	Stages		φ (/R) [']				
						Lg	Sm					
131.85	13	30440	8.6	7700	1510	2	-	-	M1-6	S97	AD5	
145.60	12	31420	8.1	7660	1510	2	-	M1-6				
161.74	11	32300	7.6	7620	1510	2	-	M1-6				
180.95	9.4	33360	7.0	7570	1510	2	-	M1-6				
8.26	206	12740	45	4290	1820	2	-	-	M1-6	S97	AD6	
9.55	178	14780	45	4310	1790	2	-	M1-6				
11.41	149	17700	45	4160	1740	2	-	M1-6				
13.07	130	19200	43	4070	1730	2	-	M1-6				
15.42	110	20360	39	4210	1730	2	-	M1-6				
17.05	100	21240	37	4250	1730	2	-	M1-6				
19.23	88	22130	34	4360	1720	2	-	M1-6				
21.23	80	22740	32	4500	1720	2	-	M1-6				
24.13	70	23630	30	5980	1910	2	-	M1-6				
27.63	62	24870	27	6200	1910	2	-	M1-6				
32.60	52	26370	25	6500	1910	2	-	M1-6				
36.05	47	27520	23	6670	1910	2	-	M1-6				
40.65	42	28590	22	6910	1900	2	-	M1-6				
44.89	38	29210	20	7140	1900	2	-	M1-6				
65.45	26	23450	13.0	7970	2100	2	-	M1-6				
78.26	22	25400	11.9	7900	2100	2	-	M1-6				
89.60	19	26730	11.0	7850	2100	2	-	M1-6				
105.71	16	28410	10.0	7790	2100	2	-	M1-6				
116.92	15	29560	9.4	7740	2100	2	-	M1-6				
131.85	13	30440	8.7	7700	2100	2	-	M1-6				
145.60	12	31420	8.2	7660	2100	2	-	M1-6				



Weight [lbs]	Stages		AD3	AD4	AD5	AD6
	Large	Small				
S97	2	-	322	334	370	400

SA97: -12 lbs / SAF97: +46 lbs / SF97: +72 lbs

11.2.11 S97R57

S97R57 AD.. , n _e = 1700 rpm										37170 lb-in		
i [ratio]	n _a [rpm]	T _a max [lb-in]	P _e [HP]	F _{Ra} ¹⁾ [lb]	F _{Re} [lb]	Stages		φ _(/R) [']				
						Lg	Sm					
205	8.3	37170	5.9	7160	270	2	2	-	-			
219	7.8	37170	5.6	7160	280	2	2	-	-			
252	6.7	37170	4.9	7150	290	2	2	-	-			
287	5.9	37170	4.3	7140	270	2	2	-	-			
327	5.2	37170	3.8	7130	280	2	2	-	-			
376	4.5	37170	3.4	7130	310	2	2	-	-			
420	4.0	37170	3.0	7120	330	2	2	-	-			
484	3.5	37170	2.7	7110	340	2	2	-	-			
538	3.2	37170	2.4	7110	340	2	2	-	-			
626	2.7	37170	2.1	7100	340	2	2	-	-			
714	2.4	37170	2.2	7370	340	2	2	-	-			
824	2.1	37170	1.6	7090	350	2	2	-	-			
928	1.8	37170	1.4	7090	300	2	2	-	-			
1070	1.6	37170	1.2	7090	280	2	2	-	-			
1223	1.4	37170	1.1	7090	330	2	2	-	-			
1394	1.2	37170	0.97	7090	340	2	2	-	-			
1574	1.1	37170	0.89	7090	380	2	3	-	-			
1860	0.91	37170	0.77	7090	380	2	3	-	-			
2081	0.82	37170	0.69	7090	380	2	3	-	-			
2329	0.73	37170	0.61	7090	380	2	3	-	-			
2654	0.64	37170	0.55	7090	380	2	3	-	-		S97R57	AD2
3108	0.55	37170	0.47	7090	380	2	3	-	-			
3453	0.49	37170	0.43	7090	380	2	3	-	-			
4017	0.42	37170	0.39	7090	390	2	3	-	-			
4444	0.38	37170	0.35	7090	390	2	3	-	-			
4937	0.34	37170	0.32	7090	390	2	3	-	-			
5780	0.29	37170	0.28	7090	390	2	3	-	-			
6640	0.26	37170	0.25	7090	390	2	3	-	-			
7554	0.23	37170	0.29	7370	390	2	3	-	-			
8608	0.20	37170	0.26	7370	390	2	3	-	-			
10078	0.17	37170	0.23	7370	390	2	3	-	-			
11267	0.15	37170	0.21	7370	390	2	3	-	-			
12752	0.13	37170	0.19	7370	400	2	3	-	-			
14576	0.12	37170	0.19	7370	400	2	3	-	-			
16233	0.10	37170	0.17	7370	400	2	3	-	-			
18749	0.09	37170	0.15	7370	400	2	3	-	-			
21537	0.08	37170	0.14	7370	400	2	3	-	-			
24641	0.07	37170	0.13	7370	400	2	3	-	-			
27847	0.06	37170	0.12	7370	400	2	3	-	-			
31154	0.05	37170	0.11	7370	400	2	3	-	-			
33818	0.05	37170	0.11	7370	400	2	3	-	-			
205	8.3	37170	6.0	7160	480	2	2	-	-			
219	7.8	37170	5.6	7160	500	2	2	-	-			
252	6.7	37170	4.9	7150	500	2	2	-	-			
287	5.9	37170	4.4	7140	490	2	2	-	-			
327	5.2	37170	3.8	7130	490	2	2	-	-			
376	4.5	37170	3.4	7130	520	2	2	-	-			
420	4.0	37170	3.1	7120	550	2	2	-	-			
484	3.5	37170	2.7	7110	550	2	2	-	-			
538	3.2	37170	2.4	7110	560	2	2	-	-			
626	2.7	37170	2.1	7100	560	2	2	-	-			
714	2.4	37170	2.2	7370	550	2	2	-	-			
824	2.1	37170	1.6	7090	570	2	2	-	-			
928	1.8	37170	1.5	7090	560	2	2	-	-			
1223	1.4	37170	1.1	7090	570	2	2	-	-			
1574	1.1	37170	0.92	7090	590	2	3	-	-			
1860	0.91	37170	0.80	7090	590	2	3	-	-		S97R57	AD3

S97R57 AD.. , $n_e = 1700$ rpm 37170 lb-in

i [ratio]	n_a [rpm]	T_a max [lb-in]	P_e [HP]	$F_{Ra}^{1)}$ [lb]	F_{Re} [lb]	Stages		ϕ (/R) [']		
						Lg	Sm			
2081	0.82	37170	0.72	7090	590	2	3	-	-	S97R57
2329	0.73	37170	0.65	7090	590	2	3	-	-	
4017	0.42	37170	0.42	7090	600	2	3	-	-	
7554	0.23	37170	0.32	7370	600	2	3	-	-	
11267	0.15	37170	0.25	7370	610	2	3	-	-	
14576	0.12	37170	0.22	7370	610	2	3	-	-	
16233	0.10	37170	0.20	7370	610	2	3	-	-	

Weight [lbs]	Stages		AD2	AD3
	Large	Small		
S97R57	2	2	366	373
	2	3	368	375

SA97: -12 lbs / SAF97: +46 lbs / SF97: +72 lbs

11.3 S.. AM.. [NEMA dimensions]

02 003 00 11

S37..

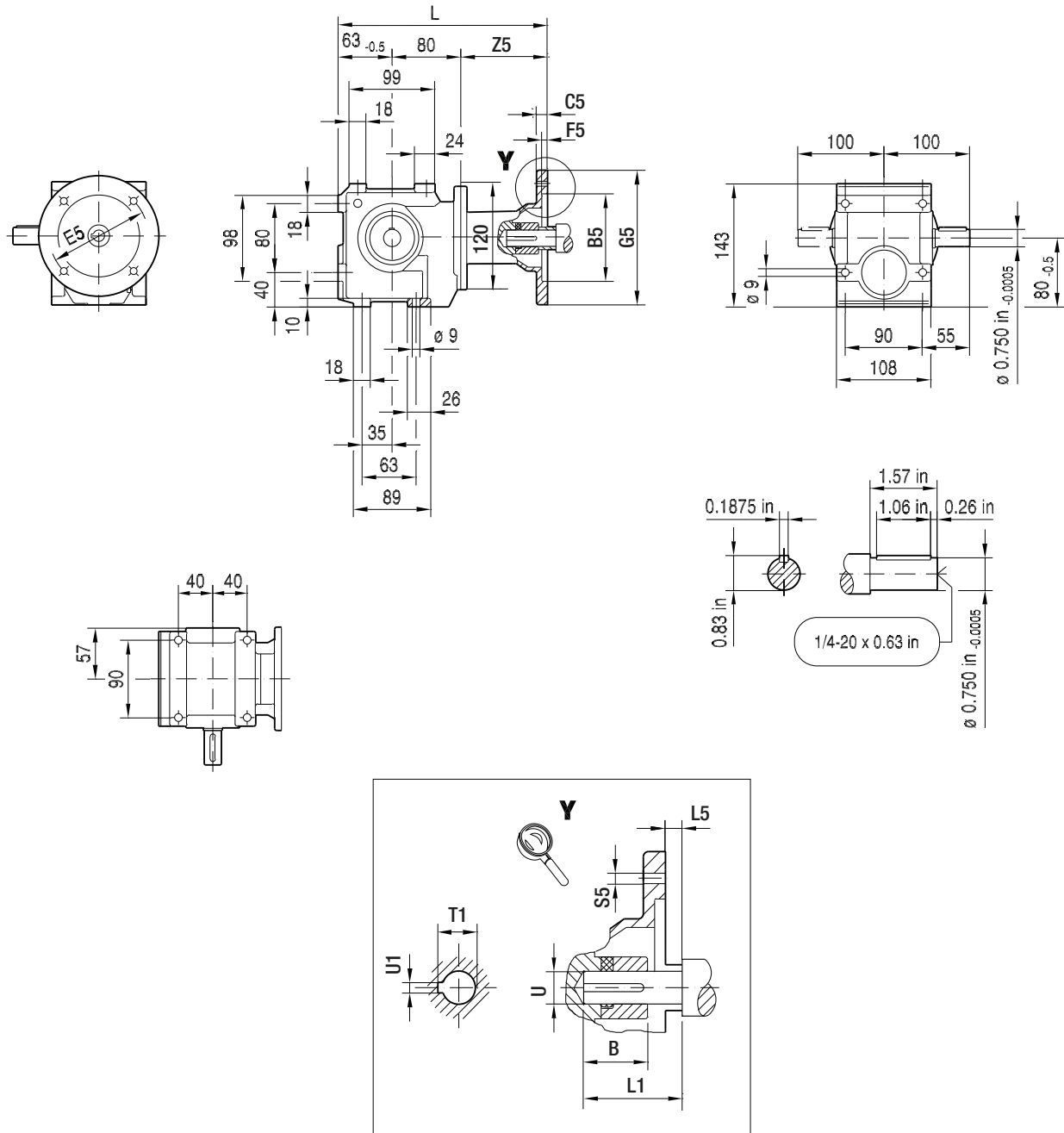

(→ 132)	B	B5	C5	E5	F5	G5	L	L1	L5	S5	T1	U	U1	Z5
AM56	1.23 in	4.50 in	11	5.875 in	4.5	170	237	1.88 in	-0.18 in	10.5	0.71 in	0.625 in	0.188 in	93.5
AM143	1.68 in	4.50 in	12	5.875 in	4.5	170	260	2.25 in	0.13 in	10.5	0.98 in	0.875 in	0.188 in	117
AM145	1.68 in	4.50 in	12	5.875 in	4.5	170	260	2.25 in	0.13 in	10.5	0.98 in	0.875 in	0.188 in	117

Dimensions in mm unless otherwise noted. For all available output shaft diameters, see page 682.

SF37..

02 004 00 11

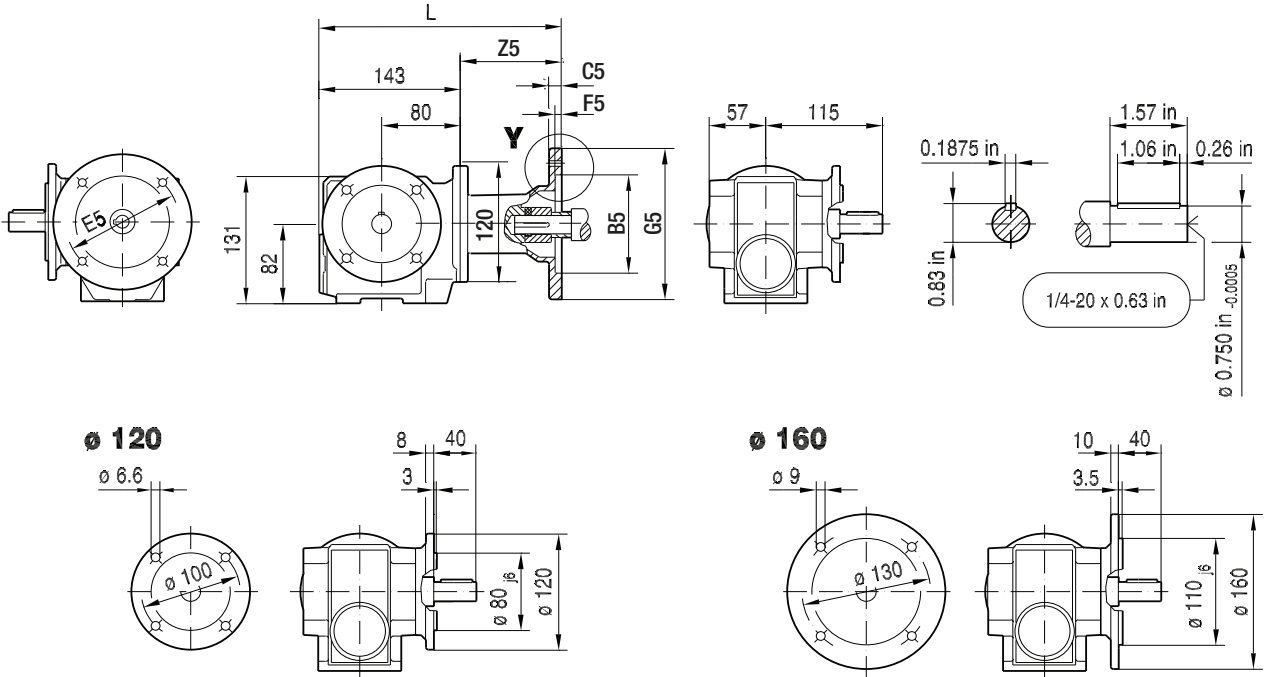

SHF37..

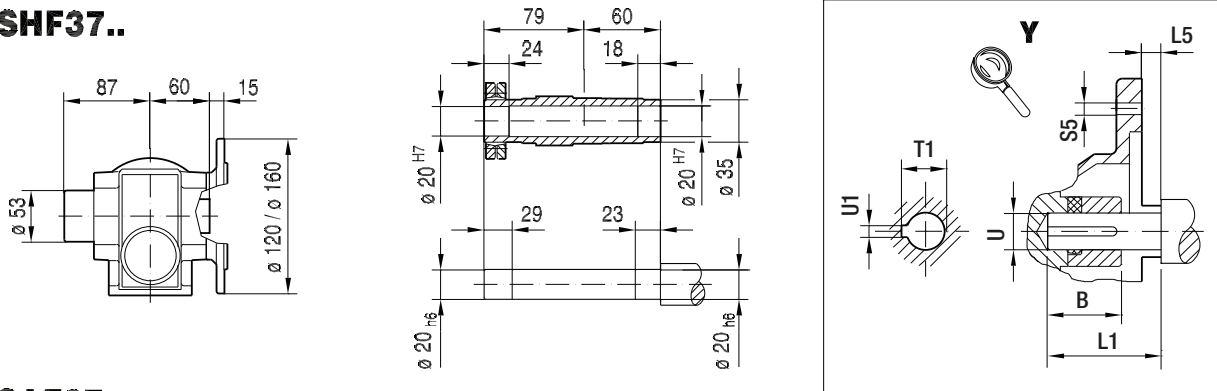

SAF37..

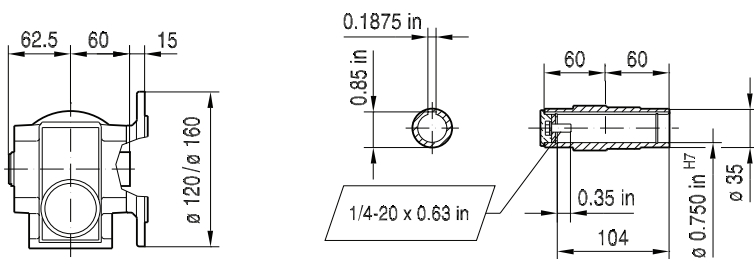

(→ 132)	B	B5	C5	E5	F5	G5	L	L1	L5	S5	T1	U	U1	Z5
AM56	1.23 in	4.50 in	11	5.875 in	4.5	170	237	1.88 in	-0.18 in	10.5	0.71 in	0.625 in	0.188 in	93.5
AM143	1.68 in	4.50 in	12	5.875 in	4.5	170	260	2.25 in	0.13 in	10.5	0.98 in	0.875 in	0.188 in	117
AM145	1.68 in	4.50 in	12	5.875 in	4.5	170	260	2.25 in	0.13 in	10.5	0.98 in	0.875 in	0.188 in	117

Dimensions in mm unless otherwise noted. For all available output shaft diameters, see page 682.

02 005 00 11

SA37..

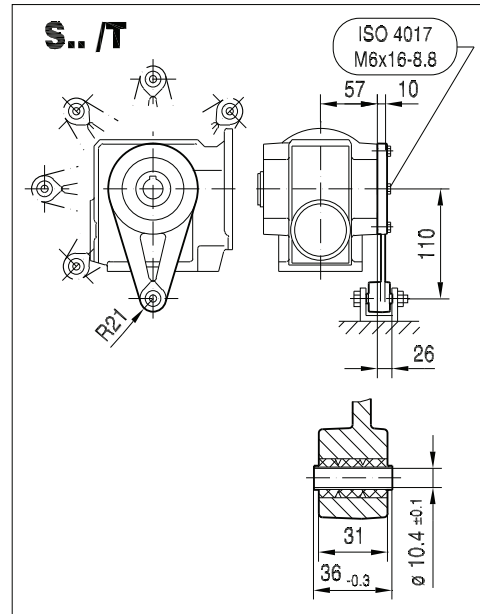
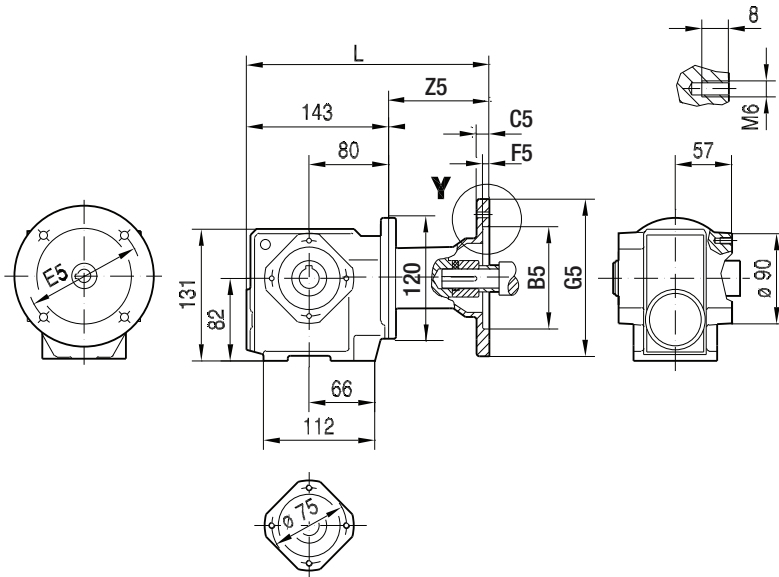

SA37..

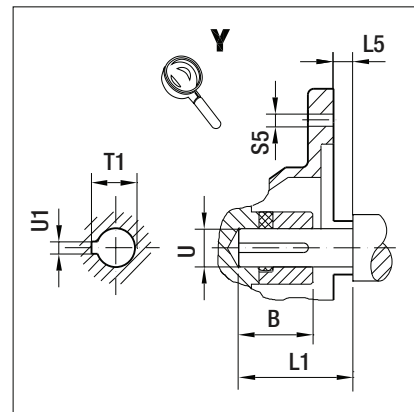
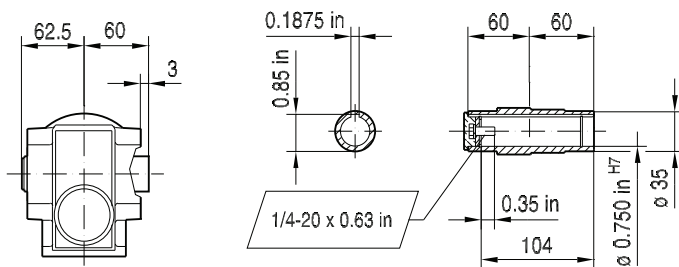

SH37..

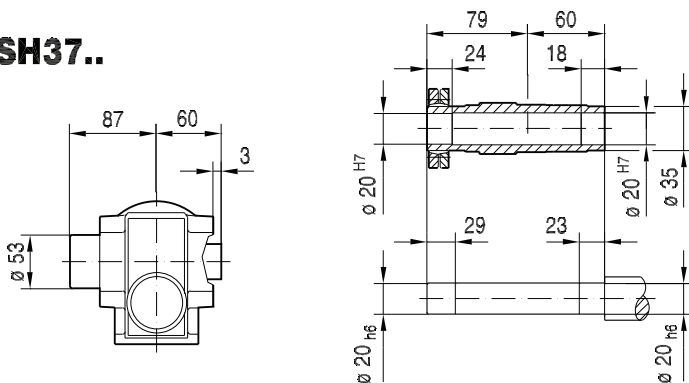

(→ 132)	B	B5	C5	E5	F5	G5	L	L1	L5	S5	T1	U	U1	Z5
AM56	1.23 in	4.50 in	11	5.875 in	4.5	170	237	1.88 in	-0.18 in	10.5	0.71 in	0.625 in	0.188 in	93.5
AM143	1.68 in	4.50 in	12	5.875 in	4.5	170	260	2.25 in	0.13 in	10.5	0.98 in	0.875 in	0.188 in	117
AM145	1.68 in	4.50 in	12	5.875 in	4.5	170	260	2.25 in	0.13 in	10.5	0.98 in	0.875 in	0.188 in	117

Dimensions in mm unless otherwise noted. For all available output shaft diameters, see page 684.

02 006 00 11

ST37..

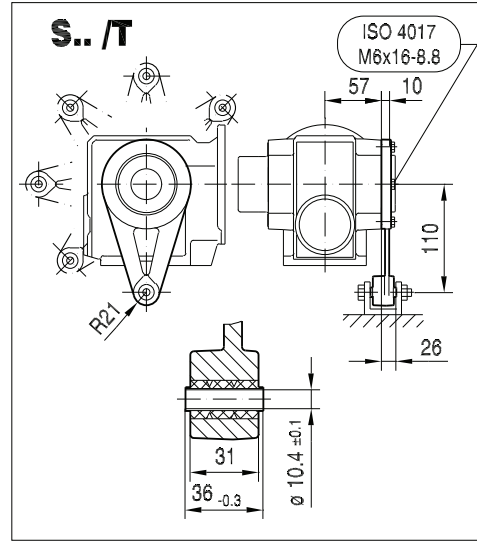
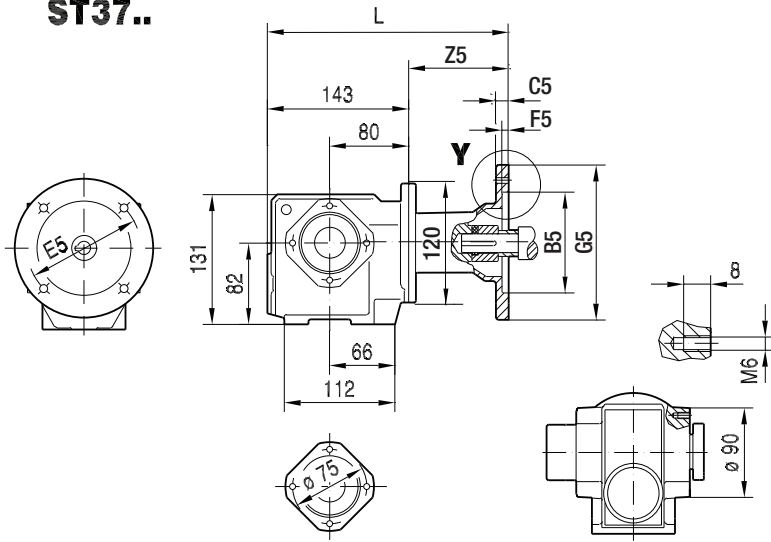

NON-Symmetrical

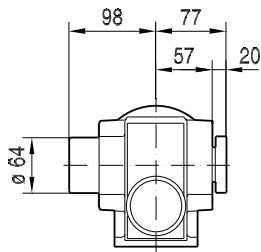

Symmetrical

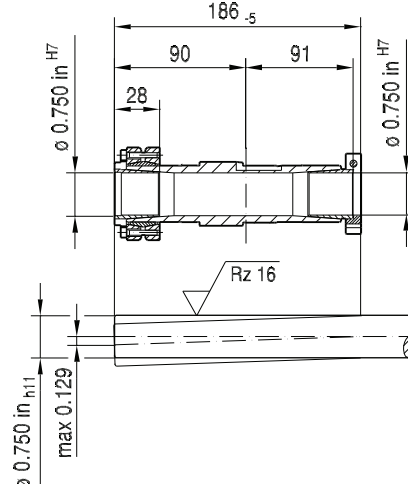
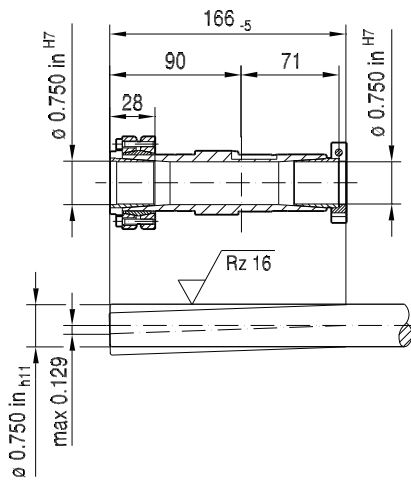
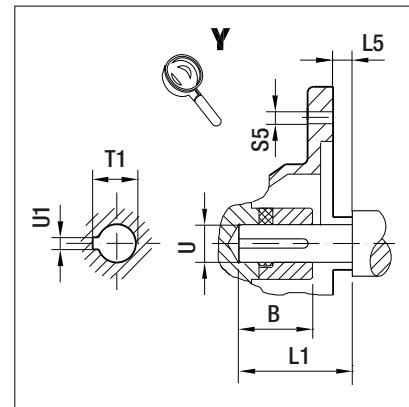
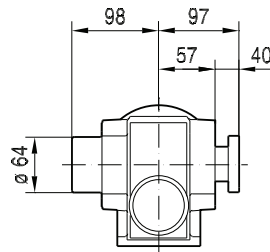

(→ 132)	B	B5	C5	E5	F5	G5	L	L1	L5	S5	T1	U	U1	Z5
AM56	1.23 in	4.50 in	11	5.875 in	4.5	170	237	1.88 in	-0.18 in	10.5	0.71 in	0.625 in	0.188 in	93.5
AM143	1.68 in	4.50 in	12	5.875 in	4.5	170	260	2.25 in	0.13 in	10.5	0.98 in	0.875 in	0.188 in	117
AM145	1.68 in	4.50 in	12	5.875 in	4.5	170	260	2.25 in	0.13 in	10.5	0.98 in	0.875 in	0.188 in	117

Dimensions in mm unless otherwise noted. For all available output shaft diameters, see page 686.

02 007 00 11

S47..

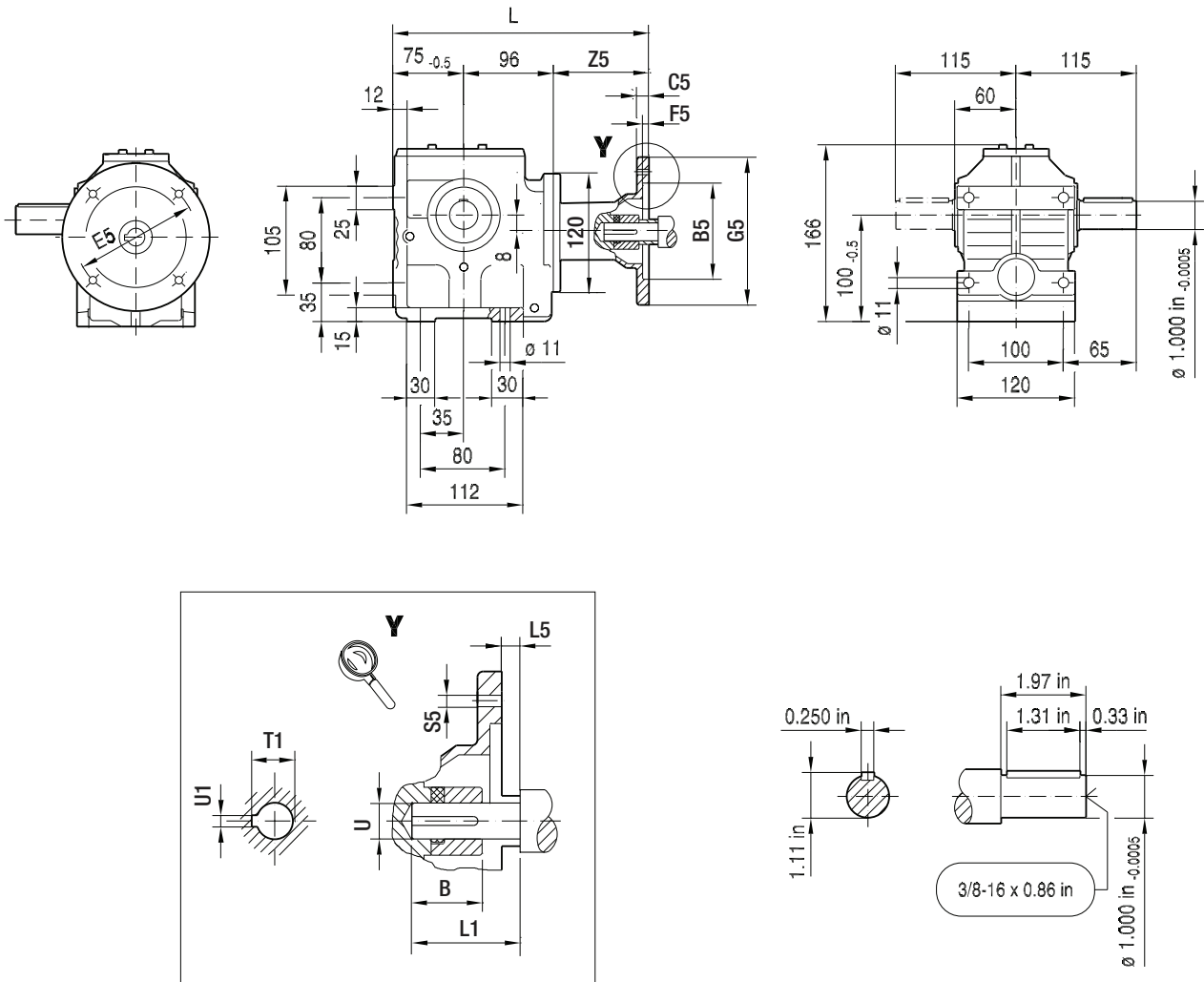

(→ 132)	B	B5	C5	E5	F5	G5	L	L1	L5	S5	T1	U	U1	Z5
AM56	1.23 in	4.50 in	11	5.875 in	4.5	170	265	1.88 in	-0.18 in	10.5	0.71 in	0.625 in	0.188 in	93.5
AM143	1.68 in	4.50 in	12	5.875 in	4.5	170	288	2.25 in	0.13 in	10.5	0.98 in	0.875 in	0.188 in	117
AM145	1.68 in	4.50 in	12	5.875 in	4.5	170	288	2.25 in	0.13 in	10.5	0.98 in	0.875 in	0.188 in	117

Dimensions in mm unless otherwise noted. For all available output shaft diameters, see page 682.

02 008 00 11

SF47..

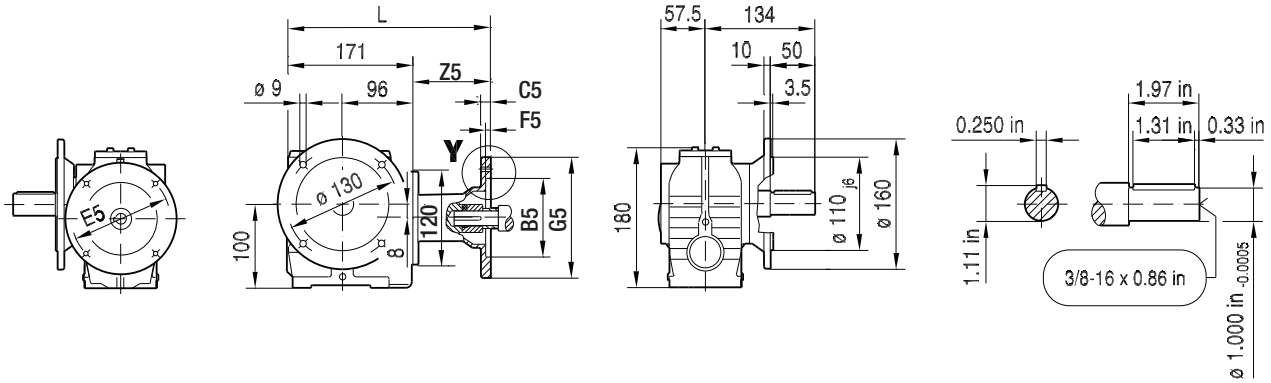

SAF47..

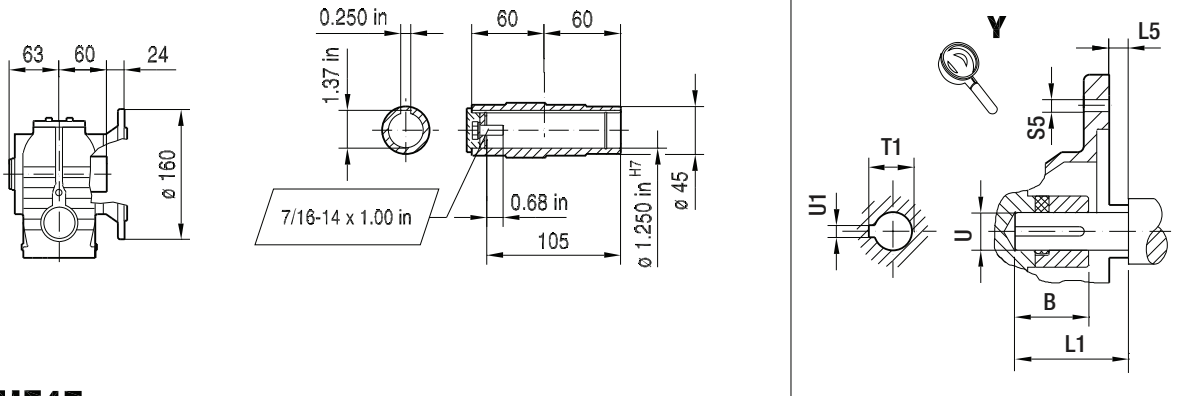

SHF47..

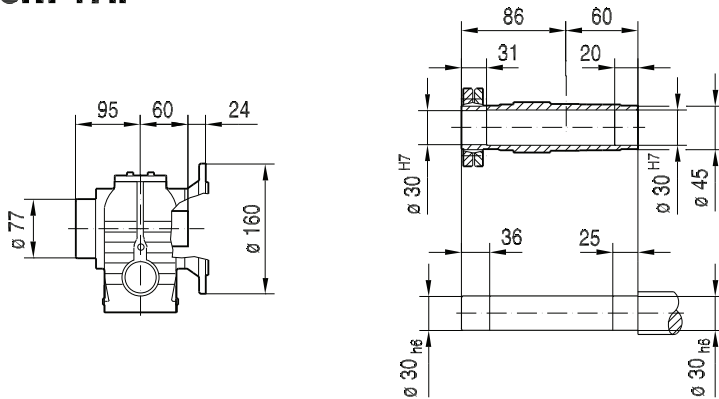

(→ 132)	B	B5	C5	E5	F5	G5	L	L1	L5	S5	T1	U	U1	Z5
AM56	1.23 in	4.50 in	11	5.875 in	4.5	170	265	1.88 in	-0.18 in	10.5	0.71 in	0.625 in	0.188 in	93.5
AM143	1.68 in	4.50 in	12	5.875 in	4.5	170	288	2.25 in	0.13 in	10.5	0.98 in	0.875 in	0.188 in	117
AM145	1.68 in	4.50 in	12	5.875 in	4.5	170	288	2.25 in	0.13 in	10.5	0.98 in	0.875 in	0.188 in	117

Dimensions in mm unless otherwise noted. For all available output shaft diameters, see page 682.

02 009 00 11

SA47..

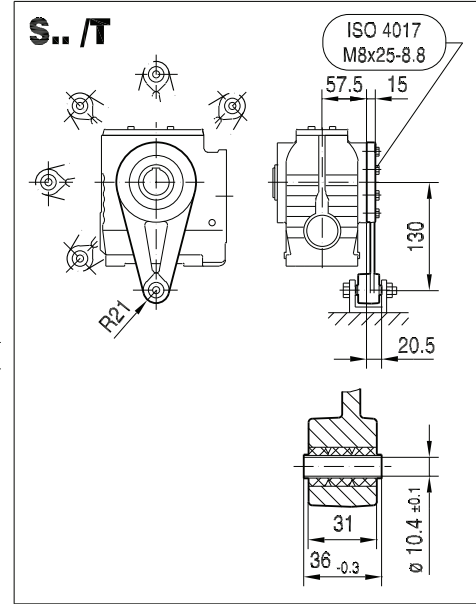
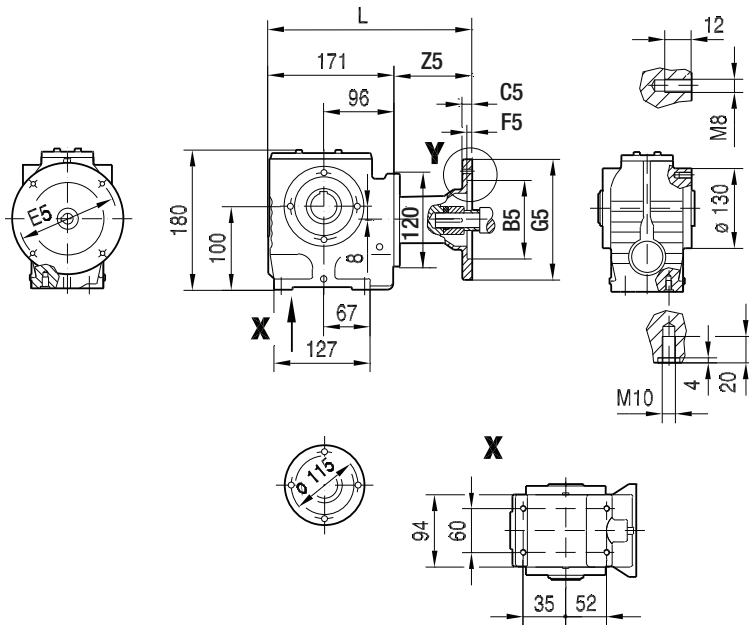

SA47..

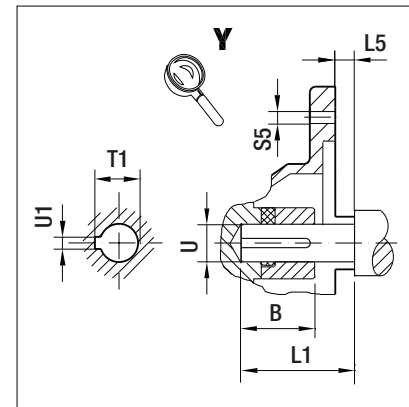
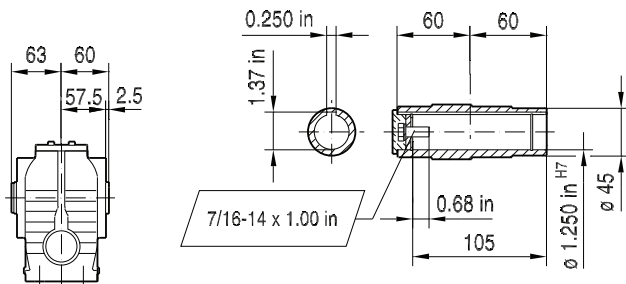

SH47..

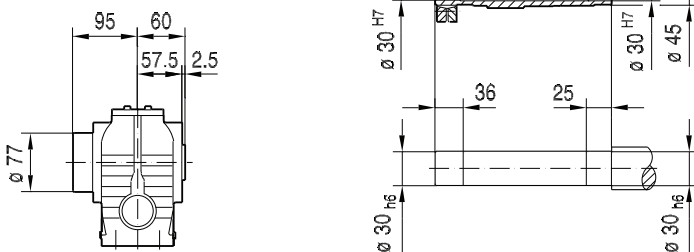

(→ 132)	B	B5	C5	E5	F5	G5	L	L1	L5	S5	T1	U	U1	Z5
AM56	1.23 in	4.50 in	11	5.875 in	4.5	170	265	1.88 in	-0.18 in	10.5	0.71 in	0.625 in	0.188 in	93.5
AM143	1.68 in	4.50 in	12	5.875 in	4.5	170	288	2.25 in	0.13 in	10.5	0.98 in	0.875 in	0.188 in	117
AM145	1.68 in	4.50 in	12	5.875 in	4.5	170	288	2.25 in	0.13 in	10.5	0.98 in	0.875 in	0.188 in	117

Dimensions in mm unless otherwise noted. For all available output shaft diameters, see page 684.

SAZ47..

02 010 00 11

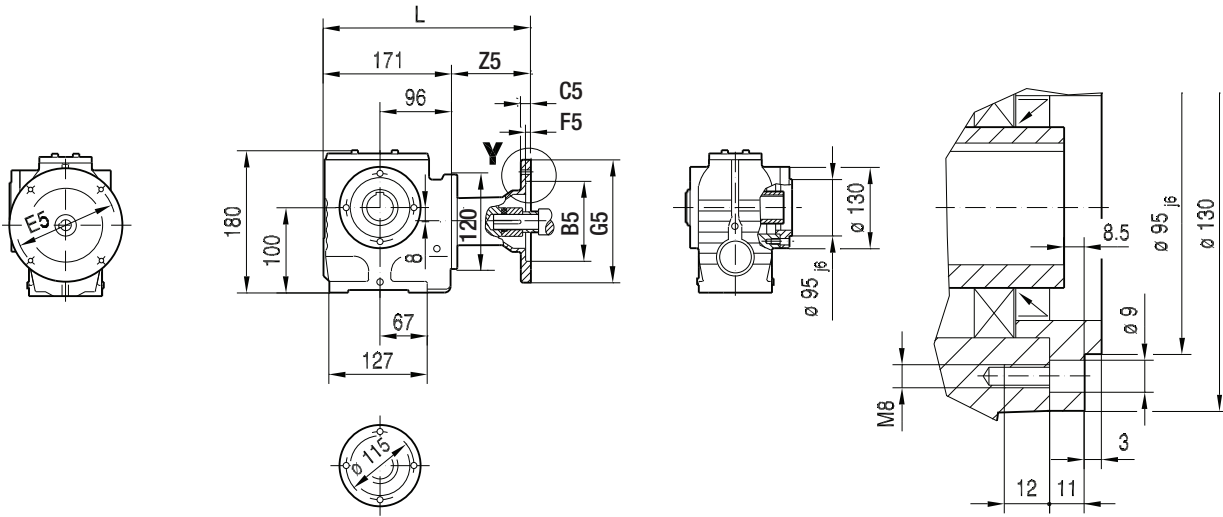

SAZ47..

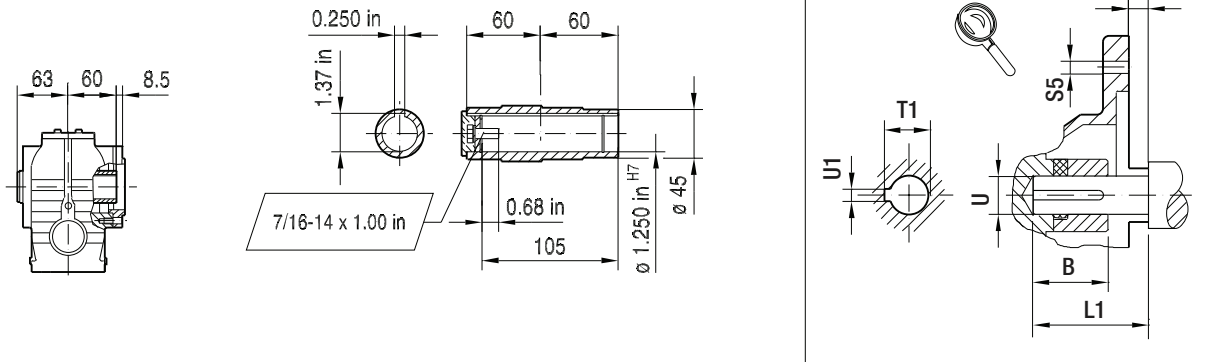

SHZ47..

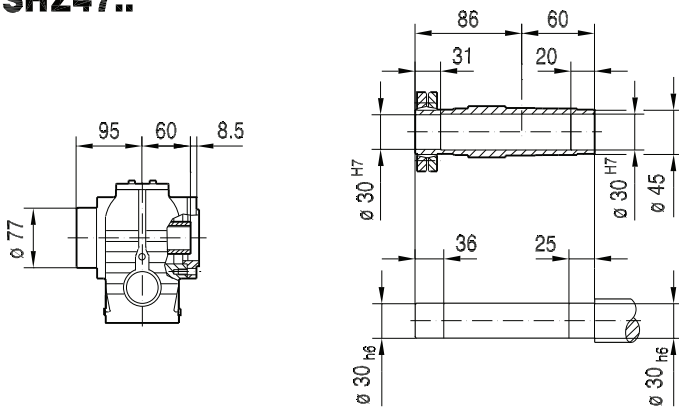

(→ 132)	B	B5	C5	E5	F5	G5	L	L1	L5	S5	T1	U	U1	Z5
AM56	1.23 in	4.50 in	11	5.875 in	4.5	170	265	1.88 in	-0.18 in	10.5	0.71 in	0.625 in	0.188 in	93.5
AM143	1.68 in	4.50 in	12	5.875 in	4.5	170	288	2.25 in	0.13 in	10.5	0.98 in	0.875 in	0.188 in	117
AM145	1.68 in	4.50 in	12	5.875 in	4.5	170	288	2.25 in	0.13 in	10.5	0.98 in	0.875 in	0.188 in	117

Dimensions in mm unless otherwise noted. For all available output shaft diameters, see page 684.

02 011 00 11

ST47..

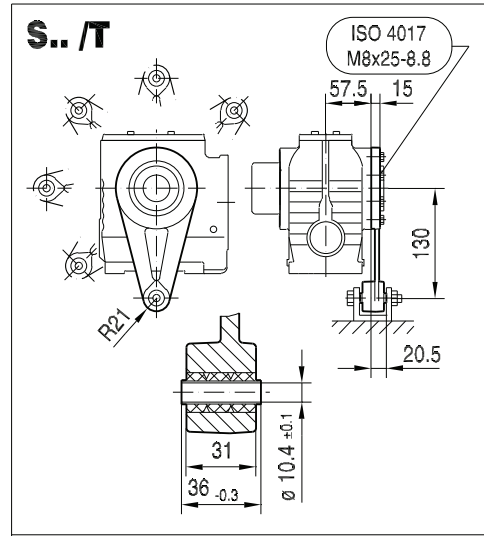
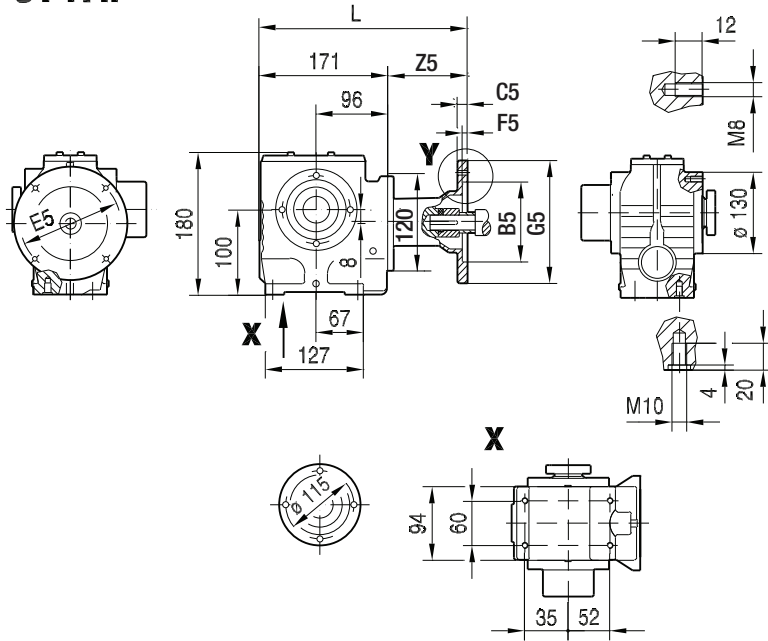

NON-Symmetrical

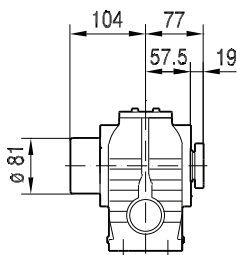

Symmetrical

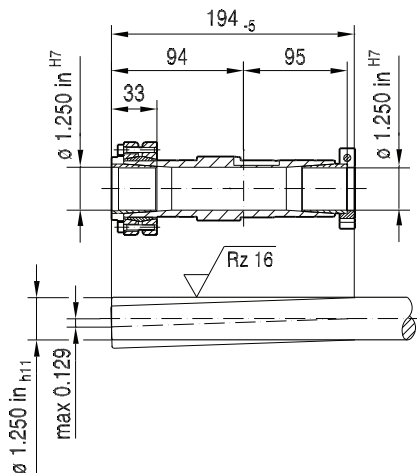
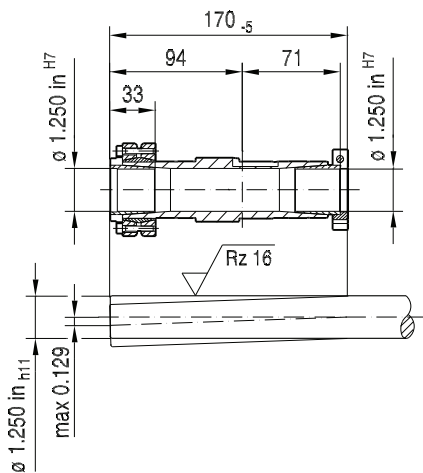
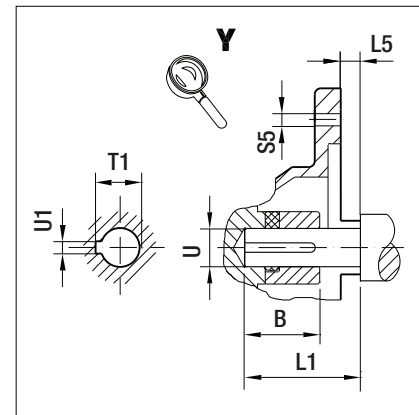
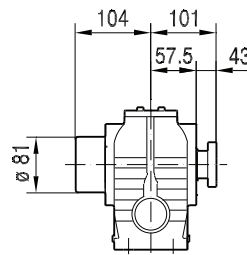

(→ 132)	B	B5	C5	E5	F5	G5	L	L1	L5	S5	T1	U	U1	Z5
AM56	1.23 in	4.50 in	11	5.875 in	4.5	170	265	1.88 in	-0.18 in	10.5	0.71 in	0.625 in	0.188 in	93.5
AM143	1.68 in	4.50 in	12	5.875 in	4.5	170	288	2.25 in	0.13 in	10.5	0.98 in	0.875 in	0.188 in	117
AM145	1.68 in	4.50 in	12	5.875 in	4.5	170	288	2.25 in	0.13 in	10.5	0.98 in	0.875 in	0.188 in	117

Dimensions in mm unless otherwise noted. For all available output shaft diameters, see page 686.

S57..

02 012 00 11

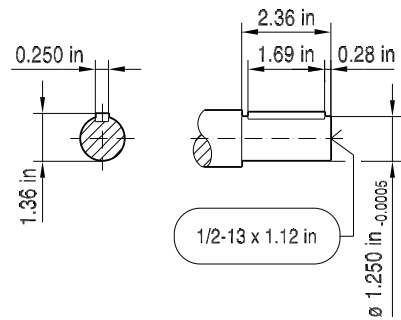
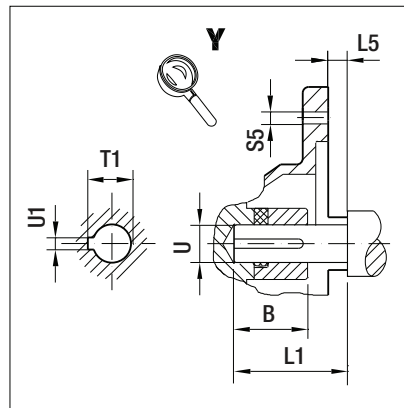
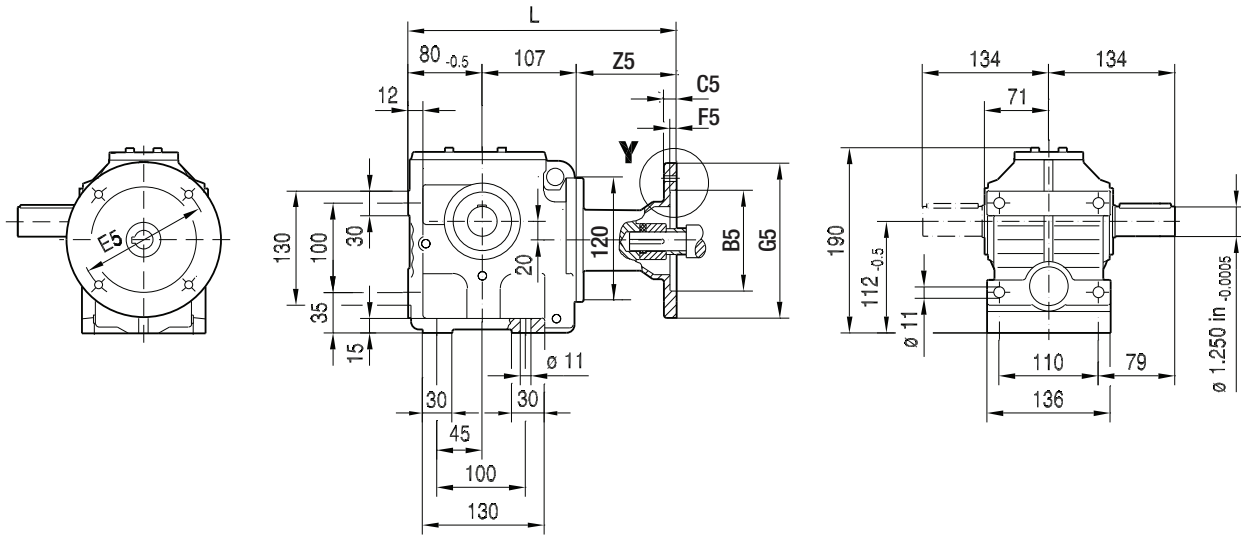

11

(→ 132)	B	B5	C5	E5	F5	G5	L	L1	L5	S5	T1	U	U1	Z5
AM56	1.23 in	4.50 in	11	5.875 in	4.5	170	281	1.88 in	-0.18 in	10.5	0.71 in	0.625 in	0.188 in	93.5
AM143	1.68 in	4.50 in	12	5.875 in	4.5	170	304	2.25 in	0.13 in	10.5	0.98 in	0.875 in	0.188 in	117
AM145	1.68 in	4.50 in	12	5.875 in	4.5	170	304	2.25 in	0.13 in	10.5	0.98 in	0.875 in	0.188 in	117

Dimensions in mm unless otherwise noted. For all available output shaft diameters, see page 682.

02 013 00 11

SF57..

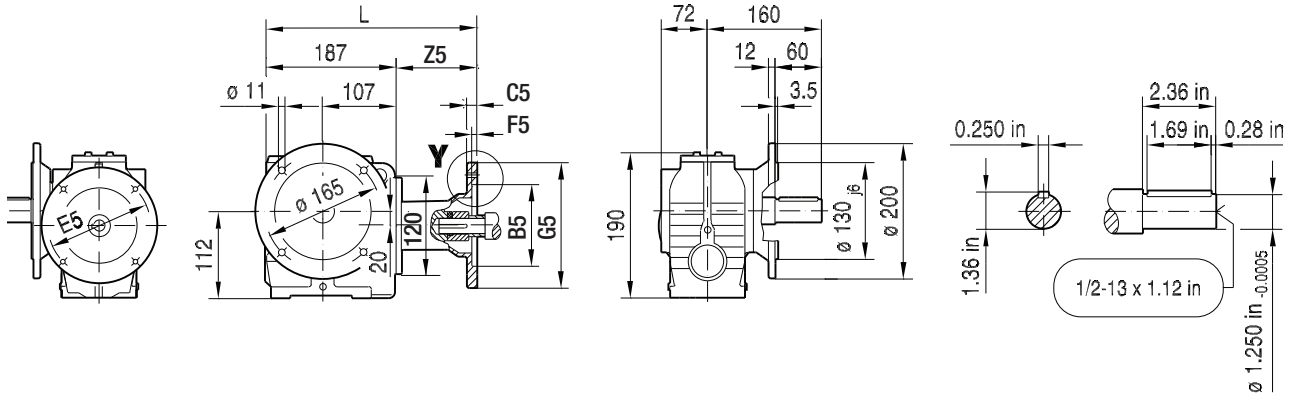

SAF57..

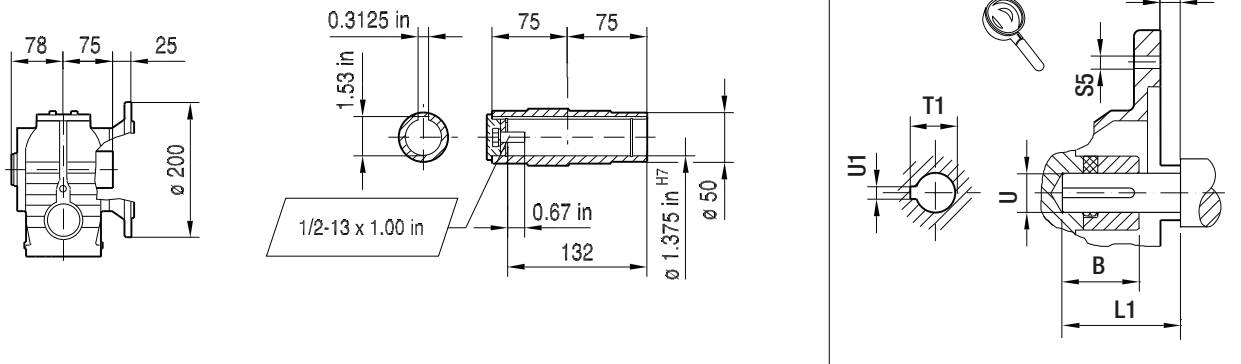

SHF57..

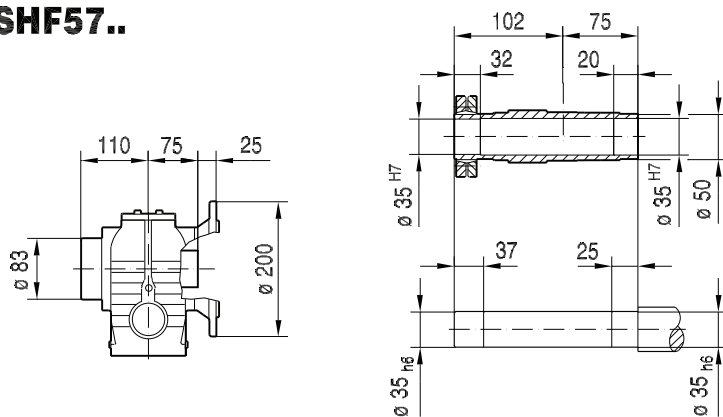

(→ 132)	B	B5	C5	E5	F5	G5	L	L1	L5	S5	T1	U	U1	Z5
AM56	1.23 in	4.50 in	11	5.875 in	4.5	170	281	1.88 in	-0.18 in	10.5	0.71 in	0.625 in	0.188 in	93.5
AM143	1.68 in	4.50 in	12	5.875 in	4.5	170	304	2.25 in	0.13 in	10.5	0.98 in	0.875 in	0.188 in	117
AM145	1.68 in	4.50 in	12	5.875 in	4.5	170	304	2.25 in	0.13 in	10.5	0.98 in	0.875 in	0.188 in	117

Dimensions in mm unless otherwise noted. For all available output shaft diameters, see page 682.

02 014 00 11

SA57..

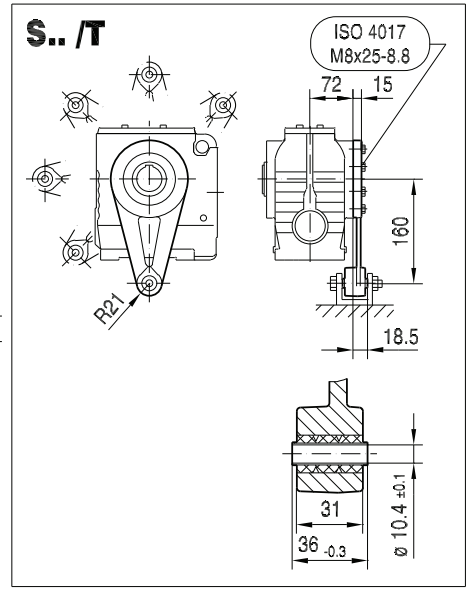
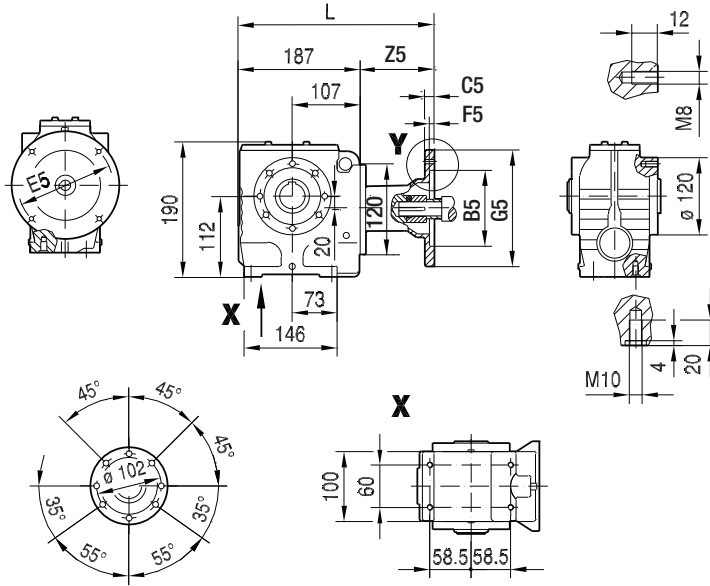

SA57..

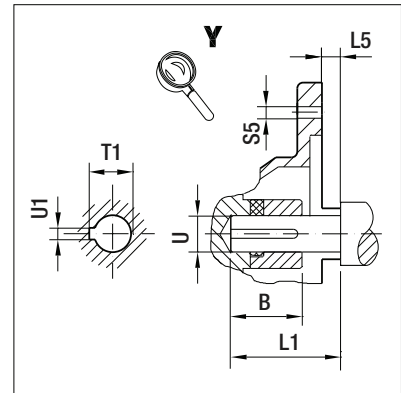
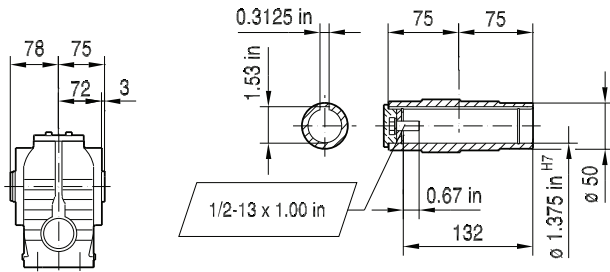

SH57..

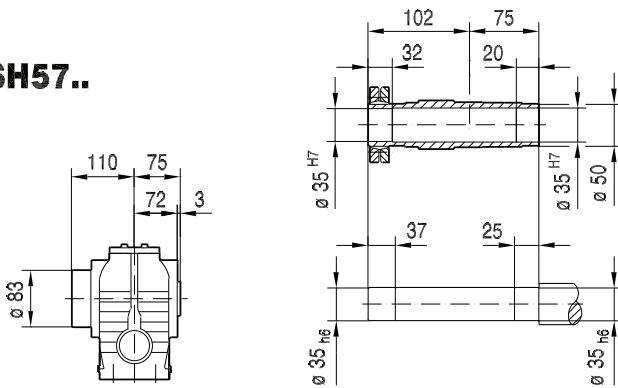

(→ 132)	B	B5	C5	E5	F5	G5	L	L1	L5	S5	T1	U	U1	Z5
AM56	1.23 in	4.50 in	11	5.875 in	4.5	170	281	1.88 in	-0.18 in	10.5	0.71 in	0.625 in	0.188 in	93.5
AM143	1.68 in	4.50 in	12	5.875 in	4.5	170	304	2.25 in	0.13 in	10.5	0.98 in	0.875 in	0.188 in	117
AM145	1.68 in	4.50 in	12	5.875 in	4.5	170	304	2.25 in	0.13 in	10.5	0.98 in	0.875 in	0.188 in	117

Dimensions in mm unless otherwise noted. For all available output shaft diameters, see page 684.

02 015 00 11

SAZ57..

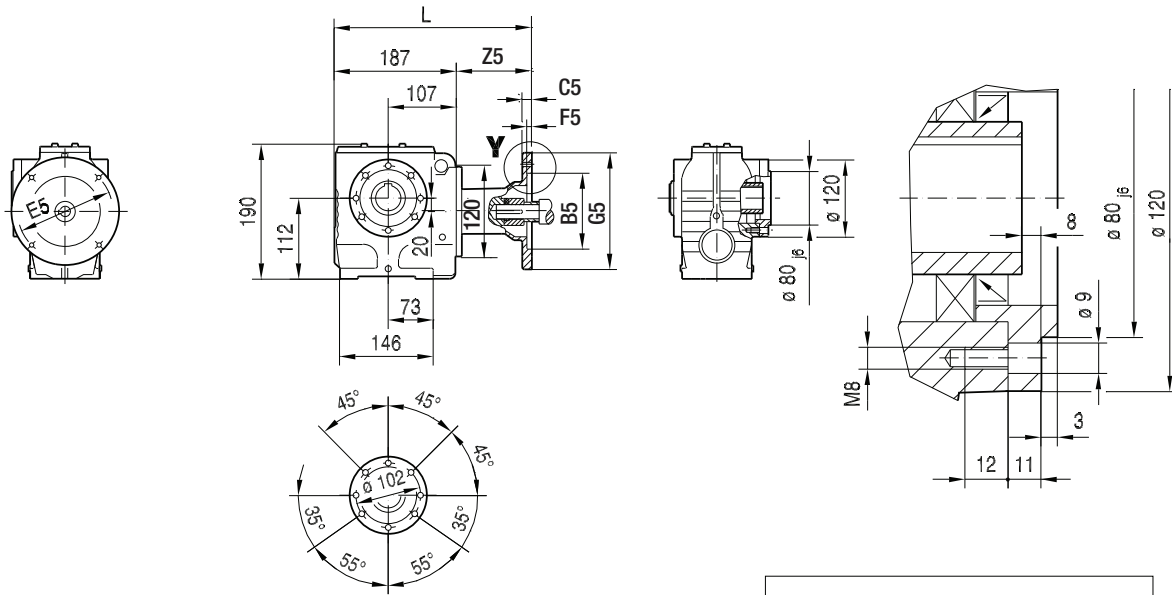

SAZ57..

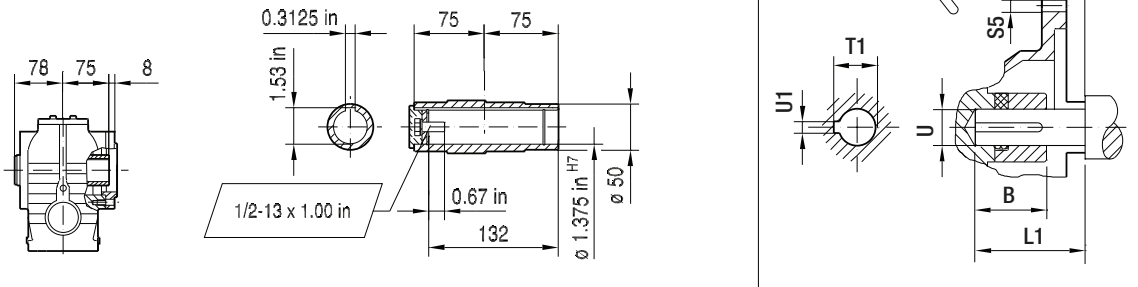

SHZ57..

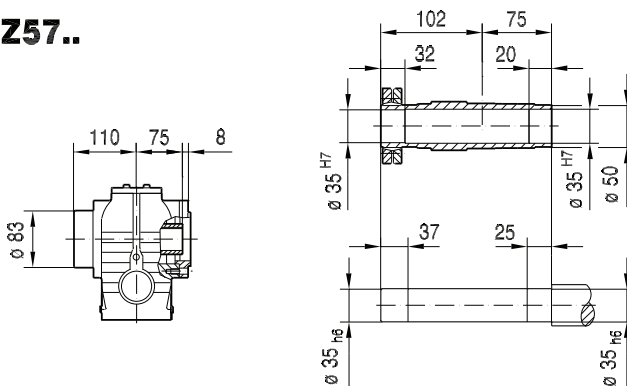

(→ 132)	B	B5	C5	E5	F5	G5	L	L1	L5	S5	T1	U	U1	Z5
AM56	1.23 in	4.50 in	11	5.875 in	4.5	170	281	1.88 in	-0.18 in	10.5	0.71 in	0.625 in	0.188 in	93.5
AM143	1.68 in	4.50 in	12	5.875 in	4.5	170	304	2.25 in	0.13 in	10.5	0.98 in	0.875 in	0.188 in	117
AM145	1.68 in	4.50 in	12	5.875 in	4.5	170	304	2.25 in	0.13 in	10.5	0.98 in	0.875 in	0.188 in	117

Dimensions in mm unless otherwise noted. For all available output shaft diameters, see page 684.

02 016 00 11

ST57..

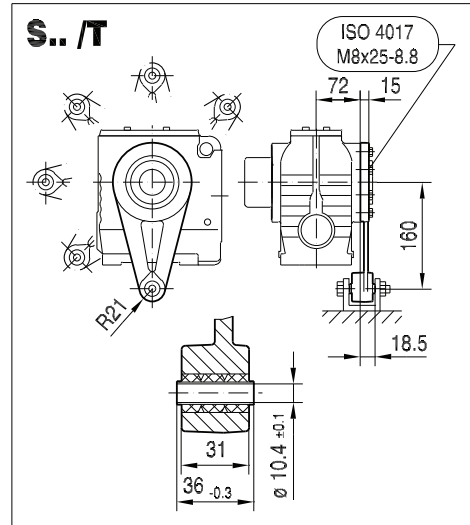
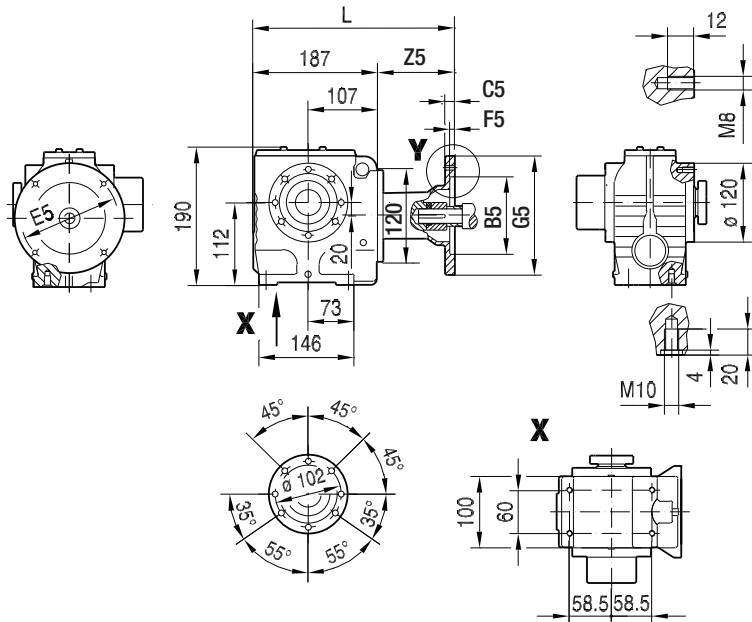

NON-Symmetrical

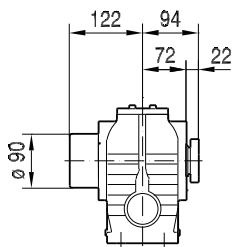

Symmetrical

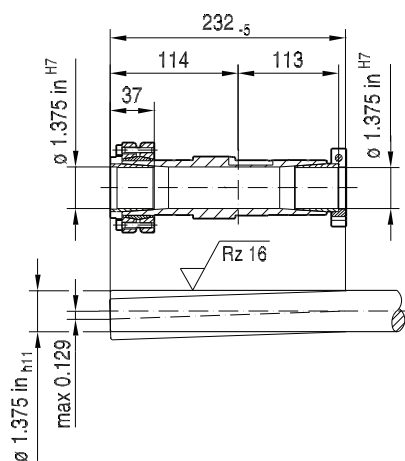
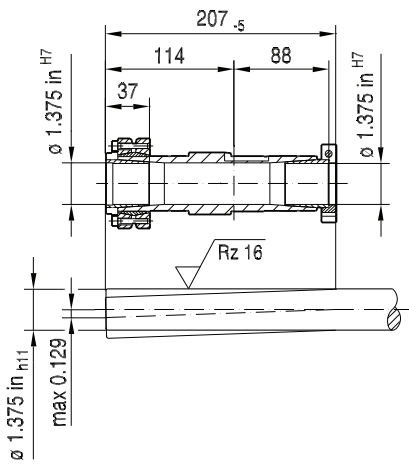
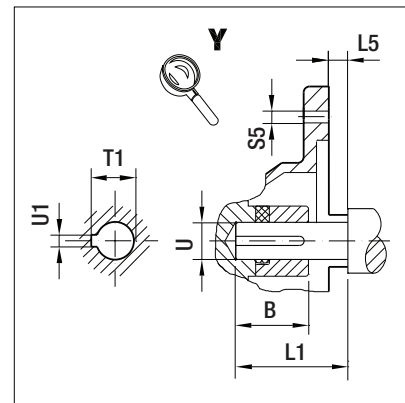
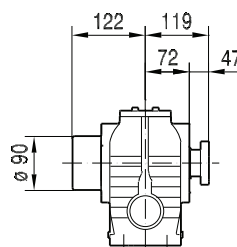

(→ 132)	B	B5	C5	E5	F5	G5	L	L1	L5	S5	T1	U	U1	Z5
AM56	1.23 in	4.50 in	11	5.875 in	4.5	170	281	1.88 in	-0.18 in	10.5	0.71 in	0.625 in	0.188 in	93.5
AM143	1.68 in	4.50 in	12	5.875 in	4.5	170	304	2.25 in	0.13 in	10.5	0.98 in	0.875 in	0.188 in	117
AM145	1.68 in	4.50 in	12	5.875 in	4.5	170	304	2.25 in	0.13 in	10.5	0.98 in	0.875 in	0.188 in	117

Dimensions in mm unless otherwise noted. For all available output shaft diameters, see page 686.

02 017 00 11

S67..

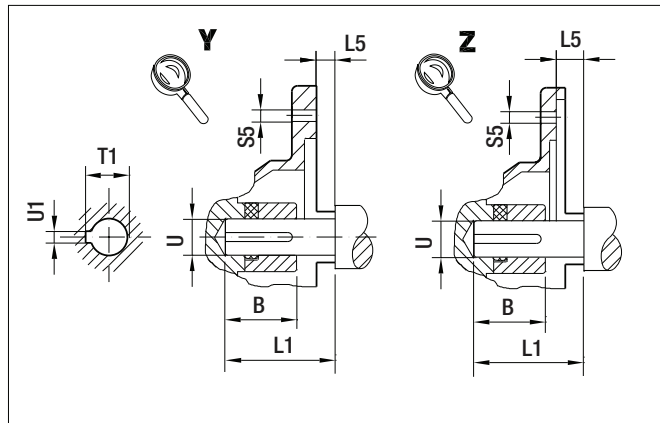
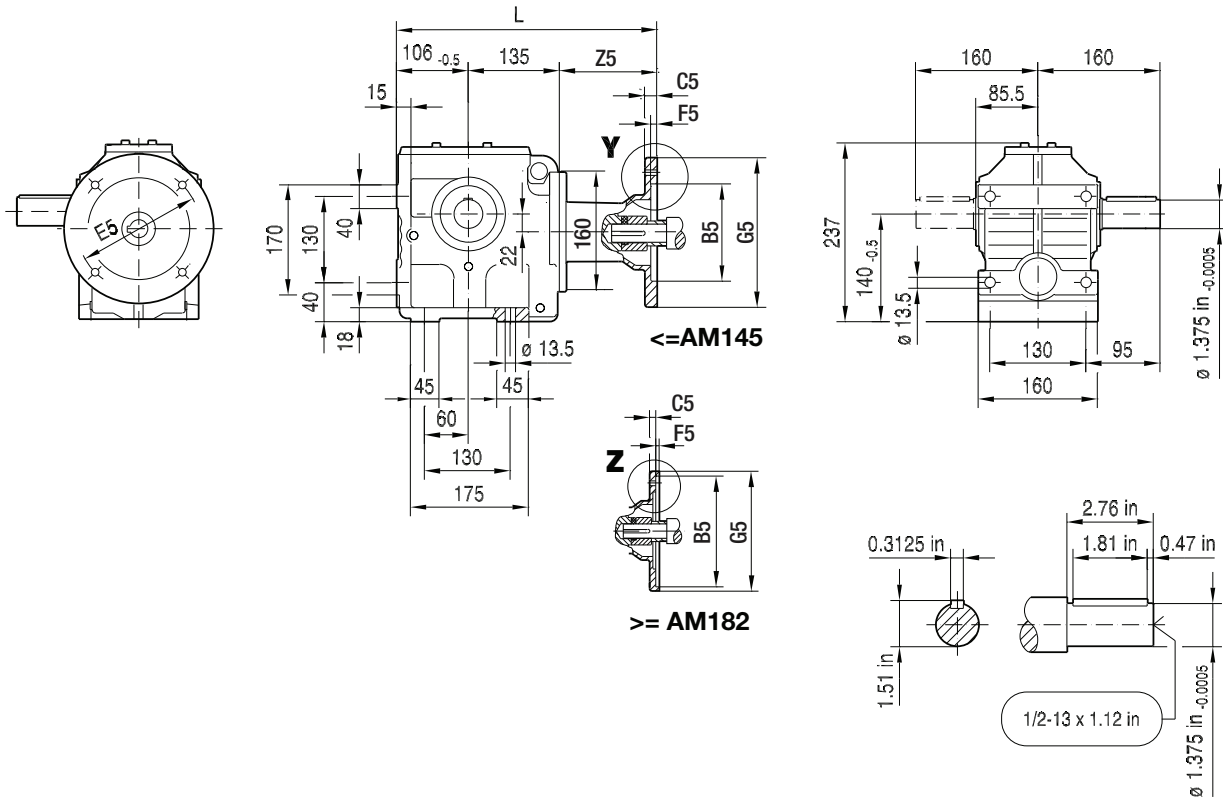

(→ 132)	B	B5	C5	E5	F5	G5	L	L1	L5	S5	T1	U	U1	Z5
AM56	1.23 in	4.50 in	11	5.875 in	4.5	170	328	1.88 in	-0.18 in	10.5	0.71 in	0.625 in	0.188 in	87
AM143	1.68 in	4.50 in	12	5.875 in	4.5	170	352	2.25 in	0.13 in	10.5	0.98 in	0.875 in	0.188 in	110.5
AM145	1.68 in	4.50 in	12	5.875 in	4.5	170	352	2.25 in	0.13 in	10.5	0.98 in	0.875 in	0.188 in	110.5
AM182	2.10 in	8.50 in	10	7.25 in	5	228	389	2.75 in	0.13 in	15	1.24 in	1.125 in	0.250 in	147.5
AM184	2.10 in	8.50 in	10	7.25 in	5	228	389	2.75 in	0.13 in	15	1.24 in	1.125 in	0.250 in	147.5
AM213/215	2.76 in	8.50 in	11	7.25 in	5	228	442	3.38 in	0.25 in	15	1.52 in	1.375 in	0.312 in	200.5

Note: Dimensions in mm unless otherwise noted. For all available output shaft diameters, see page 682. For dimensions of compound gear units (ex: S67R37) see page 648.

02 018 00 11

SF67..

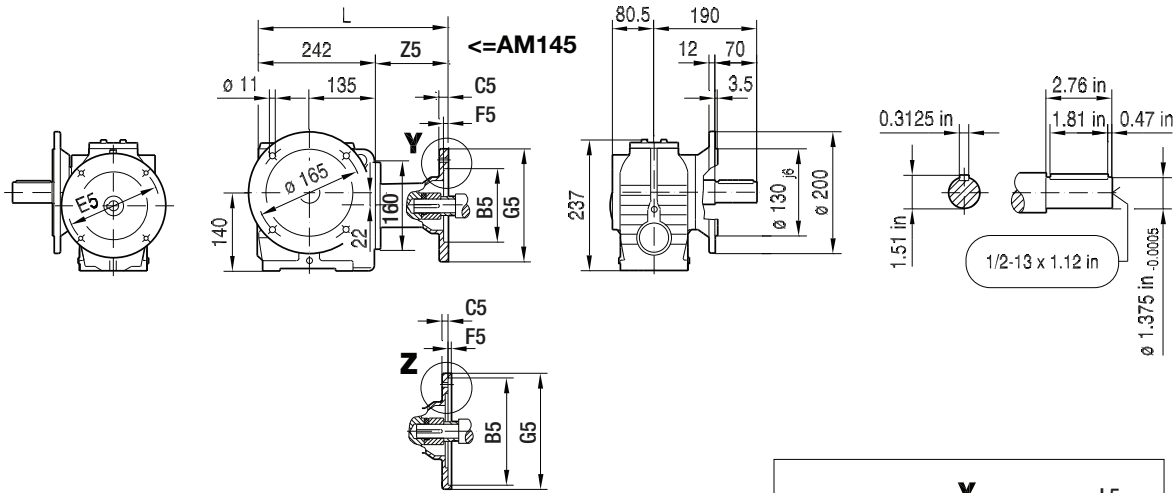

SAF67..

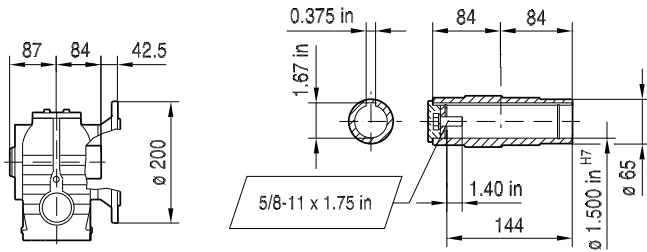

SHF67..

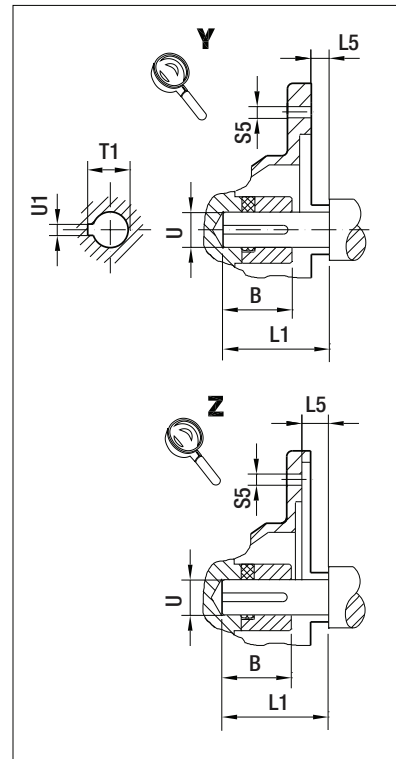
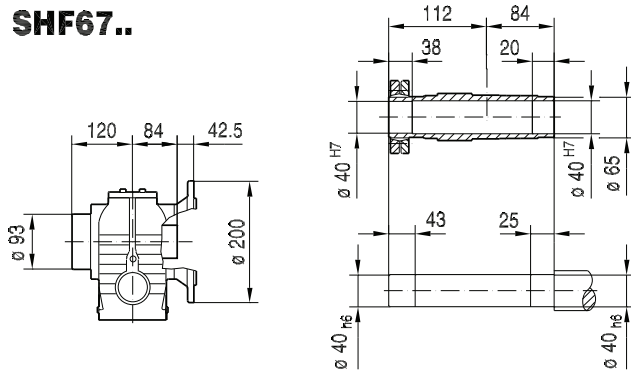

11

(→ 132)	B	B5	C5	E5	F5	G5	L	L1	L5	S5	T1	U	U1	Z5
AM56	1.23 in	4.50 in	11	5.875 in	4.5	170	329	1.88 in	-0.18 in	10.5	0.71 in	0.625 in	0.188 in	87
AM143	1.68 in	4.50 in	12	5.875 in	4.5	170	353	2.25 in	0.13 in	10.5	0.98 in	0.875 in	0.188 in	110.5
AM145	1.68 in	4.50 in	12	5.875 in	4.5	170	353	2.25 in	0.13 in	10.5	0.98 in	0.875 in	0.188 in	110.5
AM182	2.10 in	8.50 in	10	7.25 in	5	228	390	2.75 in	0.13 in	15	1.24 in	1.125 in	0.250 in	147.5
AM184	2.10 in	8.50 in	10	7.25 in	5	228	390	2.75 in	0.13 in	15	1.24 in	1.125 in	0.250 in	147.5
AM213/215	2.76 in	8.50 in	11	7.25 in	5	228	443	3.38 in	0.25 in	15	1.52 in	1.375 in	0.312 in	200.5

Note: Dimensions in mm unless otherwise noted. For all available output shaft diameters, see page 682. For dimensions of compound gear units (ex: SF67R37) see page 648.

02 019 00 11

SA67..

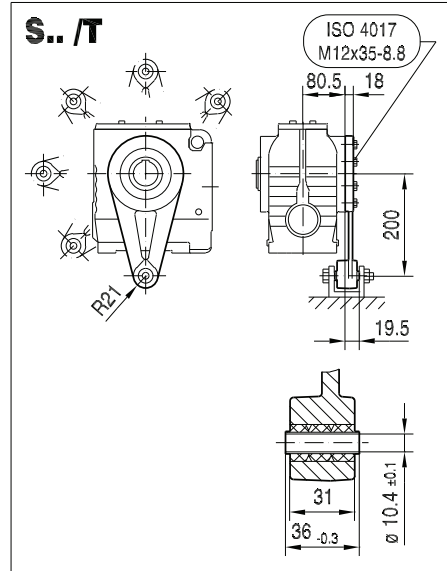
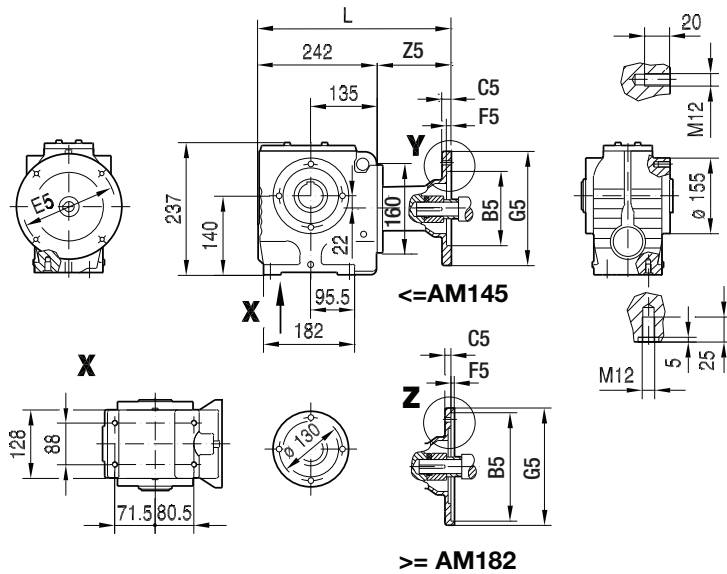

SA67..

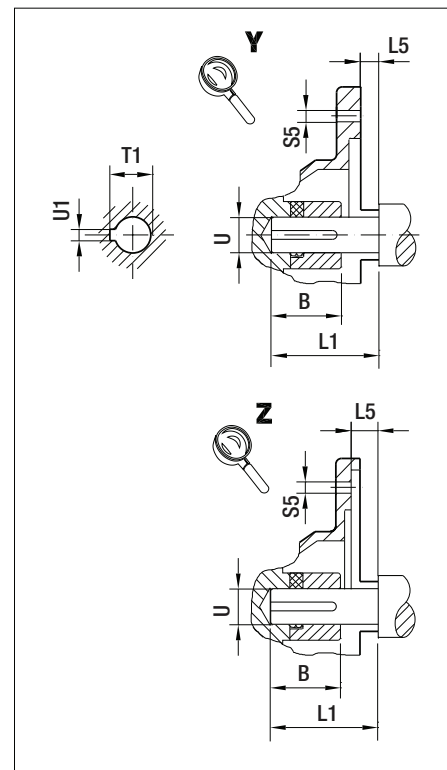
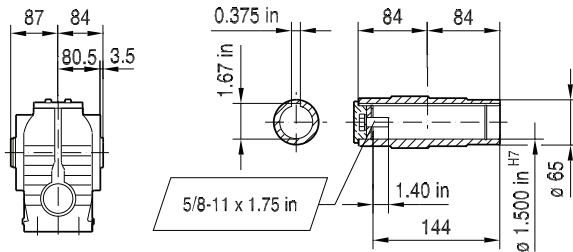

SH67..

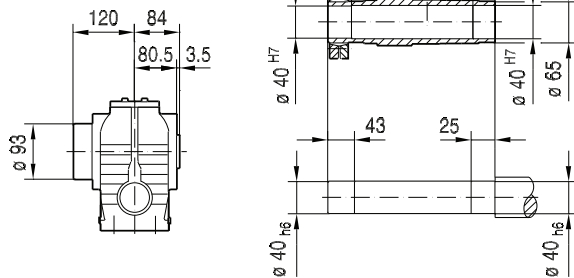

(← 132)	B	B5	C5	E5	F5	G5	L	L1	L5	S5	T1	U	U1	Z5
AM56	1.23 in	4.50 in	11	5.875 in	4.5	170	329	1.88 in	-0.18 in	10.5	0.71 in	0.625 in	0.188 in	87
AM143	1.68 in	4.50 in	12	5.875 in	4.5	170	353	2.25 in	0.13 in	10.5	0.98 in	0.875 in	0.188 in	110.5
AM145	1.68 in	4.50 in	12	5.875 in	4.5	170	353	2.25 in	0.13 in	10.5	0.98 in	0.875 in	0.188 in	110.5
AM182	2.10 in	8.50 in	10	7.25 in	5	228	390	2.75 in	0.13 in	15	1.24 in	1.125 in	0.250 in	147.5
AM184	2.10 in	8.50 in	10	7.25 in	5	228	390	2.75 in	0.13 in	15	1.24 in	1.125 in	0.250 in	147.5
AM213/215	2.76 in	8.50 in	11	7.25 in	5	228	443	3.38 in	0.25 in	15	1.52 in	1.375 in	0.312 in	200.5

Note: Dimensions in mm unless otherwise noted. For all available output shaft diameters, see page 684. For dimensions of compound gear units (ex: SA67R37) see page 648.

02 021 00 11

ST67..

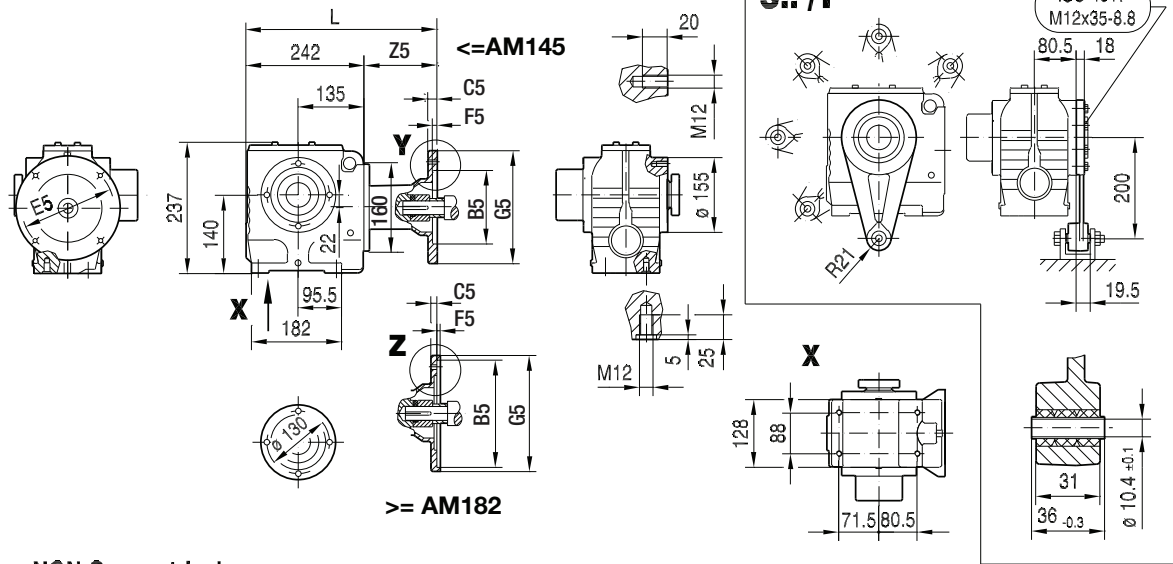

NON-Symmetrical

Symmetrical

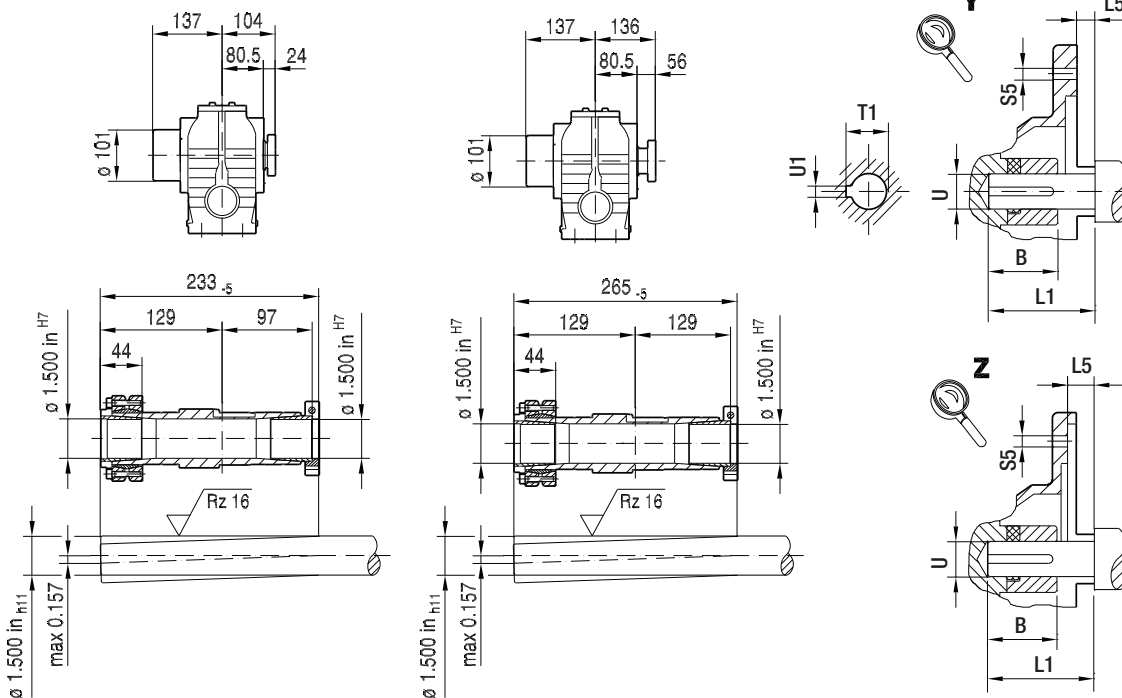

(→ 132)	B	B5	C5	E5	F5	G5	L	L1	L5	S5	T1	U	U1	Z5
AM56	1.23 in	4.50 in	11	5.875 in	4.5	170	329	1.88 in	-0.18 in	10.5	0.71 in	0.625 in	0.188 in	87
AM143	1.68 in	4.50 in	12	5.875 in	4.5	170	353	2.25 in	0.13 in	10.5	0.98 in	0.875 in	0.188 in	110.5
AM145	1.68 in	4.50 in	12	5.875 in	4.5	170	353	2.25 in	0.13 in	10.5	0.98 in	0.875 in	0.188 in	110.5
AM182	2.10 in	8.50 in	10	7.25 in	5	228	390	2.75 in	0.13 in	15	1.24 in	1.125 in	0.250 in	147.5
AM184	2.10 in	8.50 in	10	7.25 in	5	228	390	2.75 in	0.13 in	15	1.24 in	1.125 in	0.250 in	147.5
AM213/215	2.76 in	8.50 in	11	7.25 in	5	228	443	3.38 in	0.25 in	15	1.52 in	1.375 in	0.312 in	200.5

Note: Dimensions in mm unless otherwise noted. For all available output shaft diameters, see page 686. For dimensions of compound gear units (ex: ST67R37) see page 648.

S77..

02 022 00 11

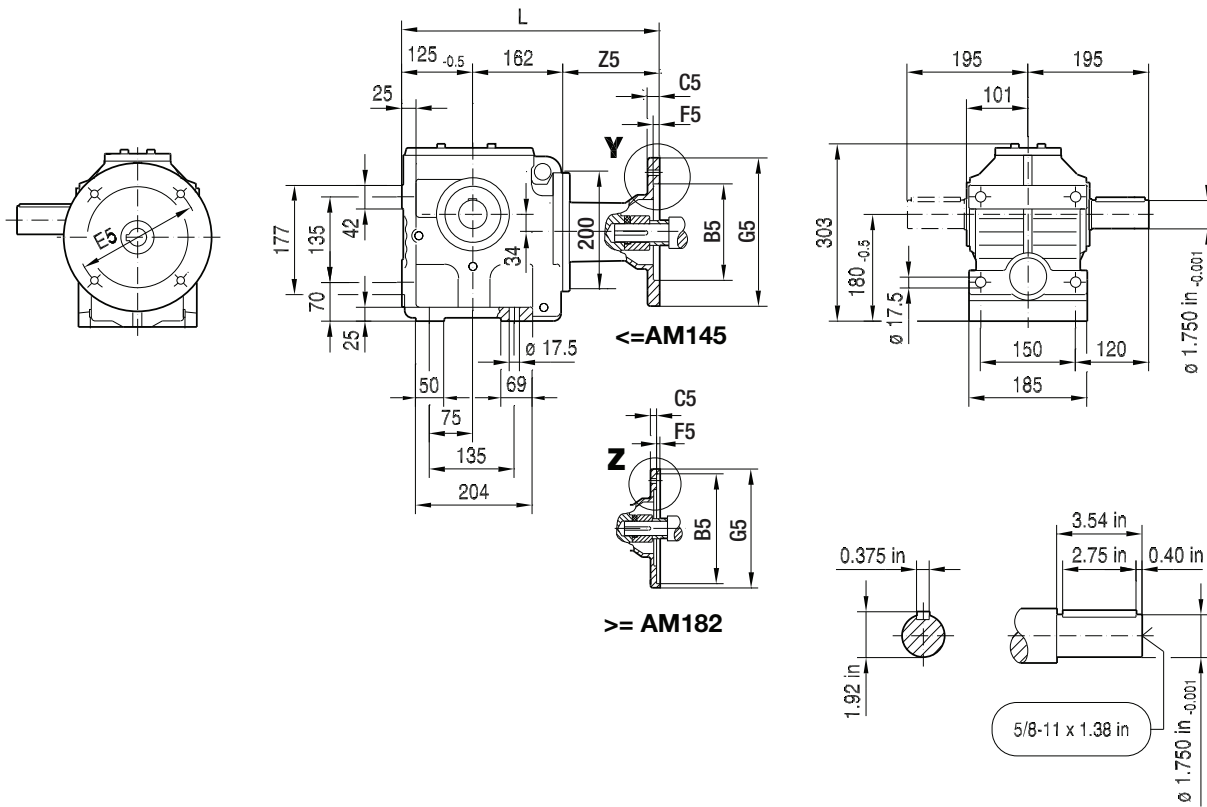

11

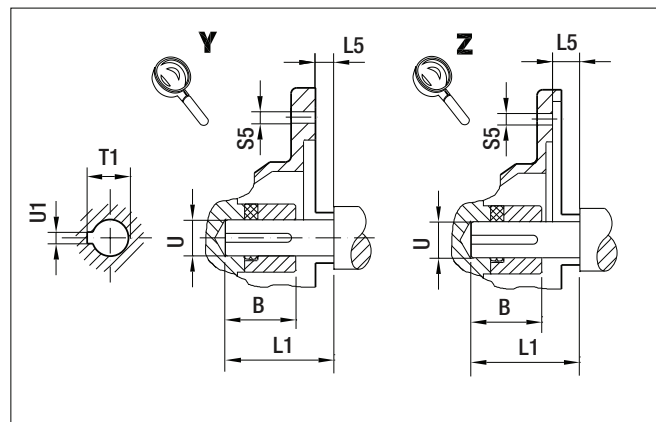

(→ 132)	B	B5	C5	E5	F5	G5	L	L1	L5	S5	T1	U	U1	Z5
AM56	1.23 in	4.50 in	11	5.875 in	4.5	170	368	1.88 in	-0.18 in	10.5	0.71 in	0.625 in	0.188 in	81
AM143	1.68 in	4.50 in	12	5.875 in	4.5	170	391	2.25 in	0.13 in	10.5	0.98 in	0.875 in	0.188 in	103.5
AM145	1.68 in	4.50 in	12	5.875 in	4.5	170	391	2.25 in	0.13 in	10.5	0.98 in	0.875 in	0.188 in	103.5
AM182	2.10 in	8.50 in	10	7.25 in	5	228	427	2.75 in	0.13 in	15	1.24 in	1.125 in	0.250 in	139.5
AM184	2.10 in	8.50 in	10	7.25 in	5	228	427	2.75 in	0.13 in	15	1.24 in	1.125 in	0.250 in	139.5
AM213/215	2.76 in	8.50 in	11	7.25 in	5	228	476	3.38 in	0.25 in	15	1.52 in	1.375 in	0.312 in	188.5

Note: Dimensions in mm unless otherwise noted. For all available output shaft diameters, see page 682. For dimensions of compound gear units (ex: S77R37) see page 648.

02 023 00 11

SF77..

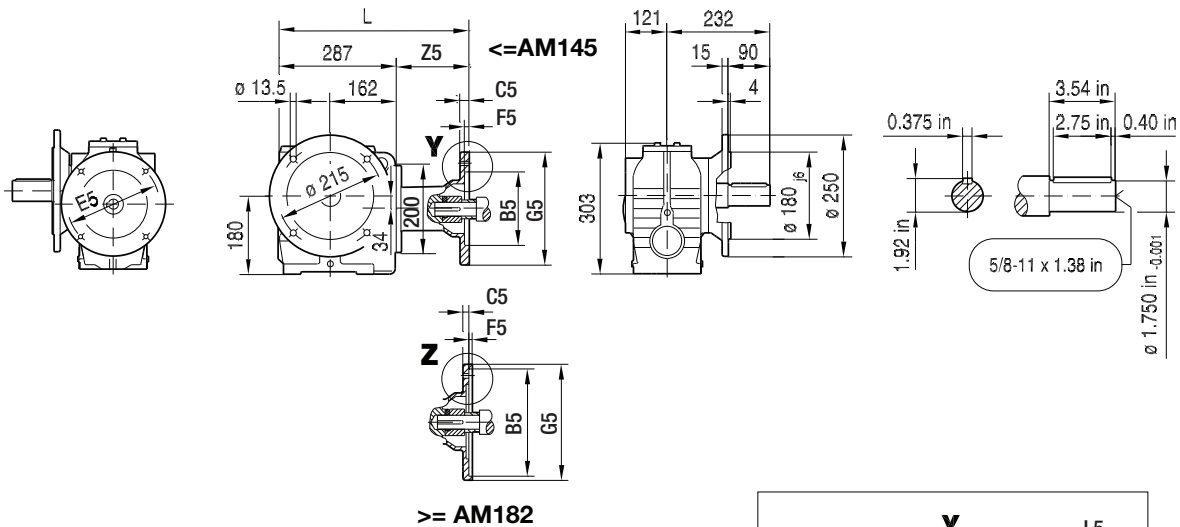

SAF77..

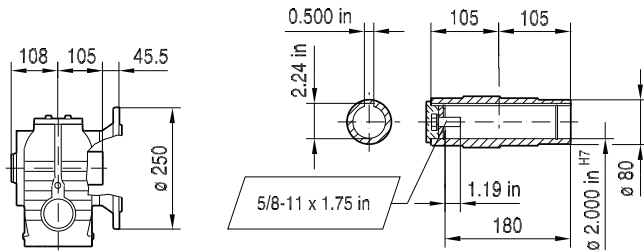

SHF77..

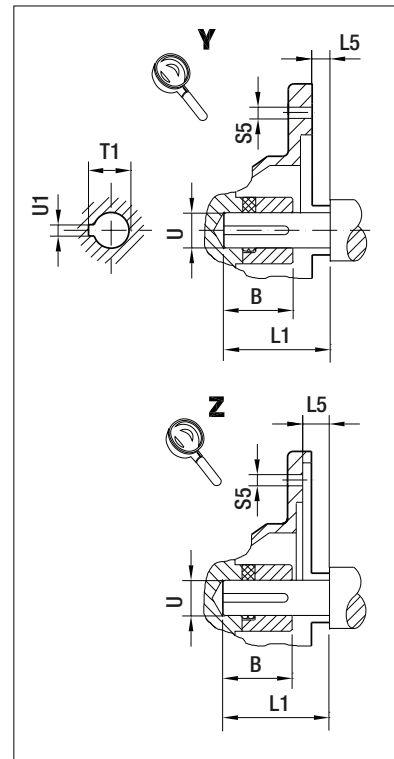
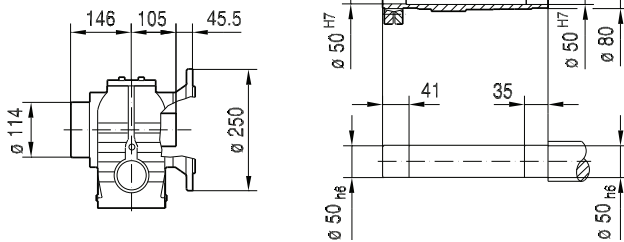

(→ 132)	B	B5	C5	E5	F5	G5	L	L1	L5	S5	T1	U	U1	Z5
AM56	1.23 in	4.50 in	11	5.875 in	4.5	170	368	1.88 in	-0.18 in	10.5	0.71 in	0.625 in	0.188 in	81
AM143	1.68 in	4.50 in	12	5.875 in	4.5	170	391	2.25 in	0.13 in	10.5	0.98 in	0.875 in	0.188 in	103.5
AM145	1.68 in	4.50 in	12	5.875 in	4.5	170	391	2.25 in	0.13 in	10.5	0.98 in	0.875 in	0.188 in	103.5
AM182	2.10 in	8.50 in	10	7.25 in	5	228	427	2.75 in	0.13 in	15	1.24 in	1.125 in	0.250 in	139.5
AM184	2.10 in	8.50 in	10	7.25 in	5	228	427	2.75 in	0.13 in	15	1.24 in	1.125 in	0.250 in	139.5
AM213/215	2.76 in	8.50 in	11	7.25 in	5	228	476	3.38 in	0.25 in	15	1.52 in	1.375 in	0.312 in	188.5

Note: Dimensions in mm unless otherwise noted. For all available output shaft diameters, see page 682. For dimensions of compound gear units (ex: SF77R37) see page 648.

02 024 00 11

SA77..

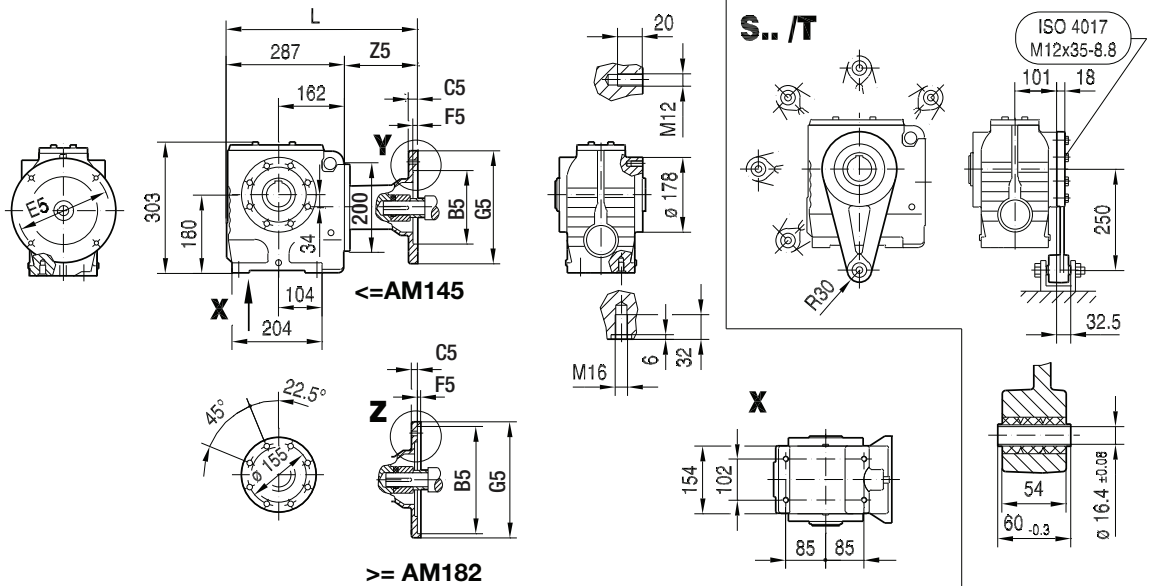

SA77..

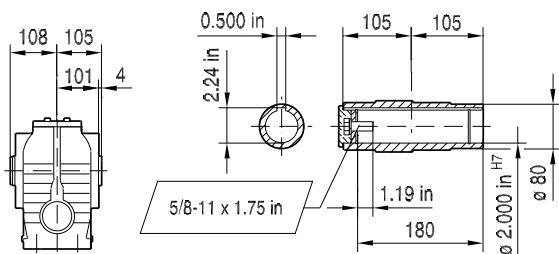

SH77..

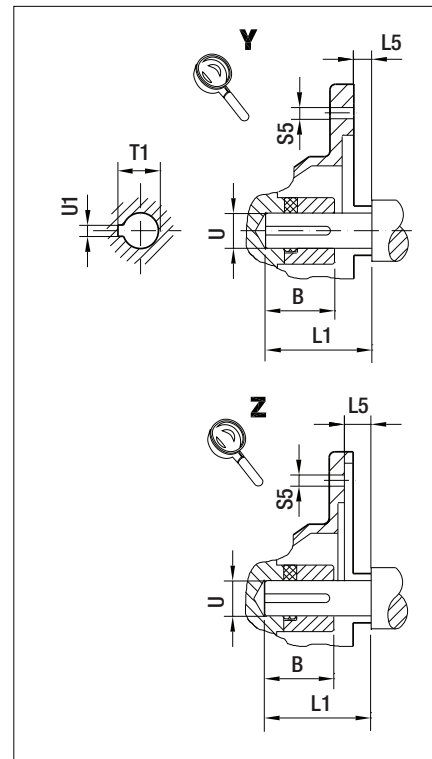
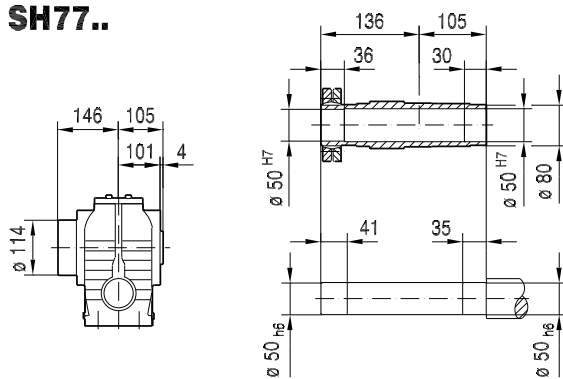

11

(→ 132)	B	B5	C5	E5	F5	G5	L	L1	L5	S5	T1	U	U1	Z5
AM56	1.23 in	4.50 in	11	5.875 in	4.5	170	368	1.88 in	-0.18 in	10.5	0.71 in	0.625 in	0.188 in	81
AM143	1.68 in	4.50 in	12	5.875 in	4.5	170	391	2.25 in	0.13 in	10.5	0.98 in	0.875 in	0.188 in	103.5
AM145	1.68 in	4.50 in	12	5.875 in	4.5	170	391	2.25 in	0.13 in	10.5	0.98 in	0.875 in	0.188 in	103.5
AM182	2.10 in	8.50 in	10	7.25 in	5	228	427	2.75 in	0.13 in	15	1.24 in	1.125 in	0.250 in	139.5
AM184	2.10 in	8.50 in	10	7.25 in	5	228	427	2.75 in	0.13 in	15	1.24 in	1.125 in	0.250 in	139.5
AM213/215	2.76 in	8.50 in	11	7.25 in	5	228	476	3.38 in	0.25 in	15	1.52 in	1.375 in	0.312 in	188.5

Note: Dimensions in mm unless otherwise noted. For all available output shaft diameters, see page 684. For dimensions of compound gear units (ex: SA77R37) see page 648.

02 025 00 11

SAZ77..

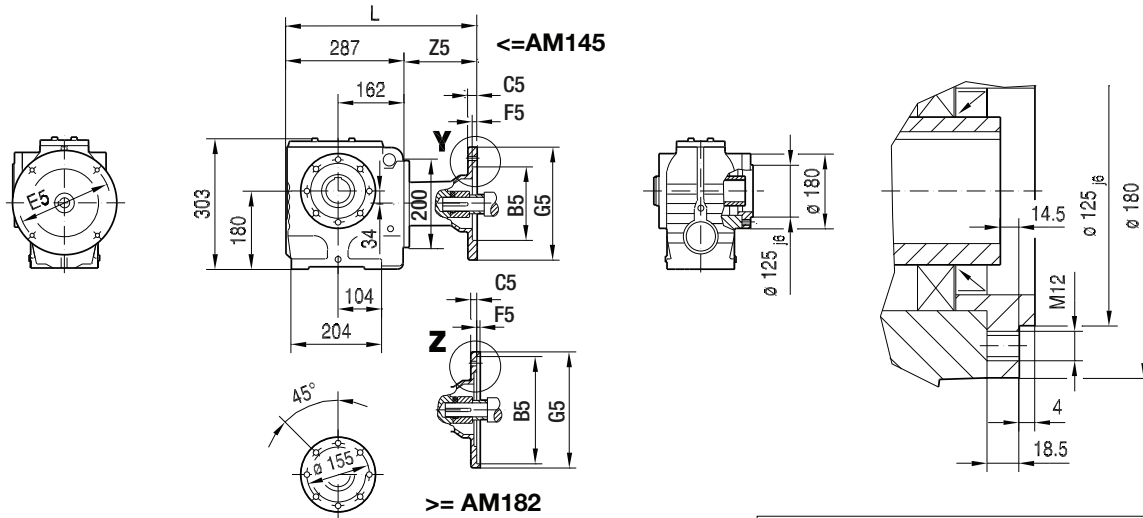

SAZ77..

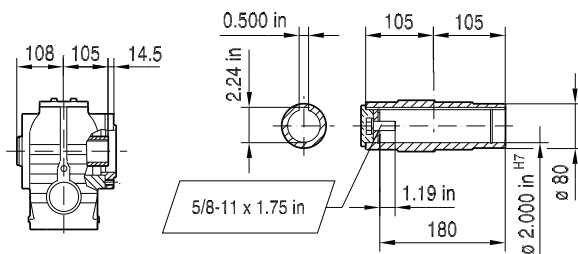

SHZ77..

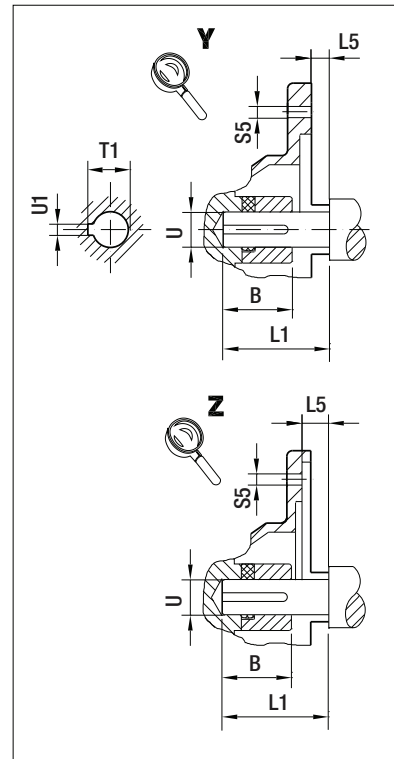
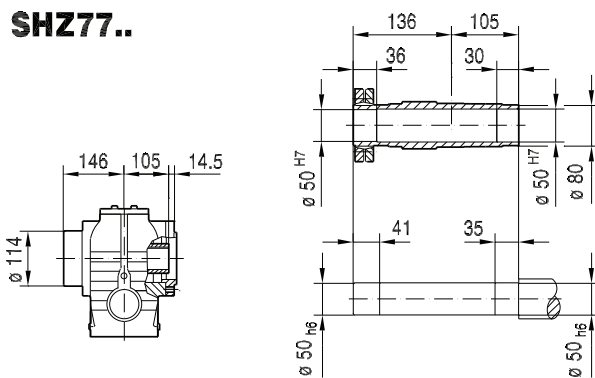

(→ 132)	B	B5	C5	E5	F5	G5	L	L1	L5	S5	T1	U	U1	Z5
AM56	1.23 in	4.50 in	11	5.875 in	4.5	170	368	1.88 in	-0.18 in	10.5	0.71 in	0.625 in	0.188 in	81
AM143	1.68 in	4.50 in	12	5.875 in	4.5	170	391	2.25 in	0.13 in	10.5	0.98 in	0.875 in	0.188 in	103.5
AM145	1.68 in	4.50 in	12	5.875 in	4.5	170	391	2.25 in	0.13 in	10.5	0.98 in	0.875 in	0.188 in	103.5
AM182	2.10 in	8.50 in	10	7.25 in	5	228	427	2.75 in	0.13 in	15	1.24 in	1.125 in	0.250 in	139.5
AM184	2.10 in	8.50 in	10	7.25 in	5	228	427	2.75 in	0.13 in	15	1.24 in	1.125 in	0.250 in	139.5
AM213/215	2.76 in	8.50 in	11	7.25 in	5	228	476	3.38 in	0.25 in	15	1.52 in	1.375 in	0.312 in	188.5

Note: Dimensions in mm unless otherwise noted. For all available output shaft diameters, see page 684. For dimensions of compound gear units (ex: SAZ77R37) see page 648.

02 027 00 11

S87..

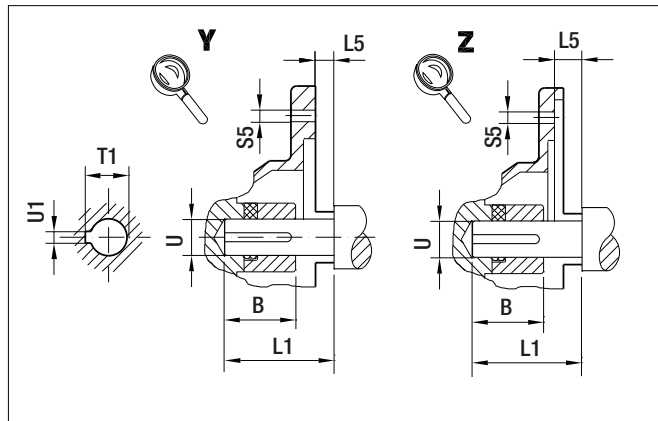
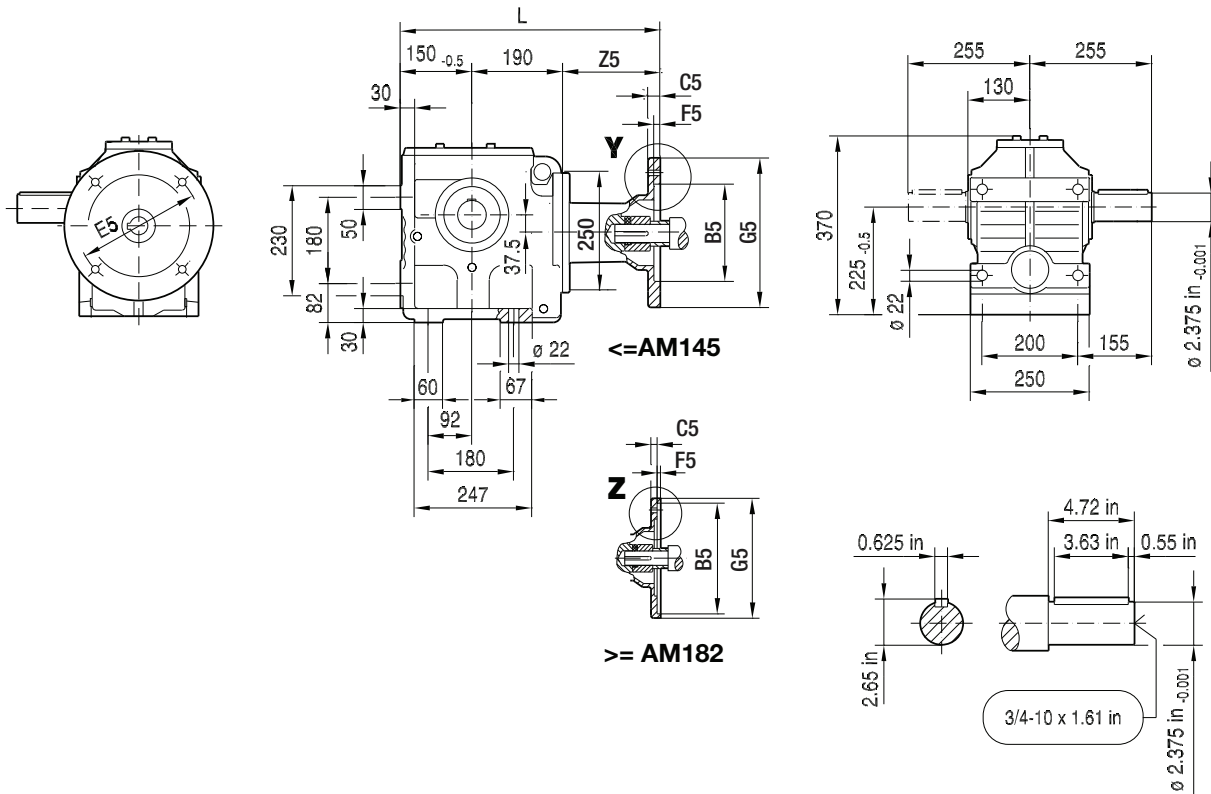

(→ 132)	B	B5	C5	E5	F5	G5	L	L1	L5	S5	T1	U	U1	Z5
AM143	1.68 in	4.50 in	12	5.875 in	4.5	170	439	2.25 in	0.13 in	10.5	0.98 in	0.875 in	0.188 in	98.5
AM145	1.68 in	4.50 in	12	5.875 in	4.5	170	439	2.25 in	0.13 in	10.5	0.98 in	0.875 in	0.188 in	98.5
AM182	2.10 in	8.50 in	10	7.25 in	5	228	475	2.75 in	0.13 in	15	1.24 in	1.125 in	0.250 in	134.5
AM184	2.10 in	8.50 in	10	7.25 in	5	228	475	2.75 in	0.13 in	15	1.24 in	1.125 in	0.250 in	134.5
AM213/215	2.76 in	8.50 in	11	7.25 in	5	228	524	3.38 in	0.25 in	15	1.52 in	1.375 in	0.312 in	183.5
AM254/256	3.65 in	8.50 in	14	7.25 in	5	228	574	4.00 in	0.25 in	15	1.80 in	1.625 in	0.375 in	234
AM284/286	4.00 in	10.50 in	15	9.00 in	5	286	581	4.62 in	0.25 in	15	2.10 in	1.875 in	0.500 in	241

Note: Dimensions in mm unless otherwise noted. For all available output shaft diameters, see page 682. For dimensions of compound gear units (ex: S87R57) see page 648.

02 028 00 11

SF87..

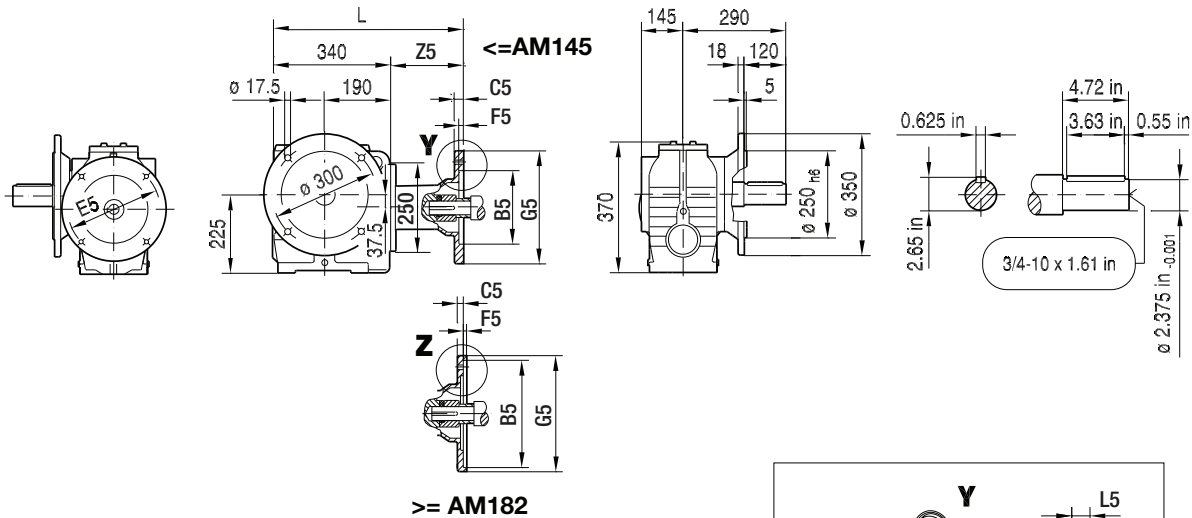

SAF87..

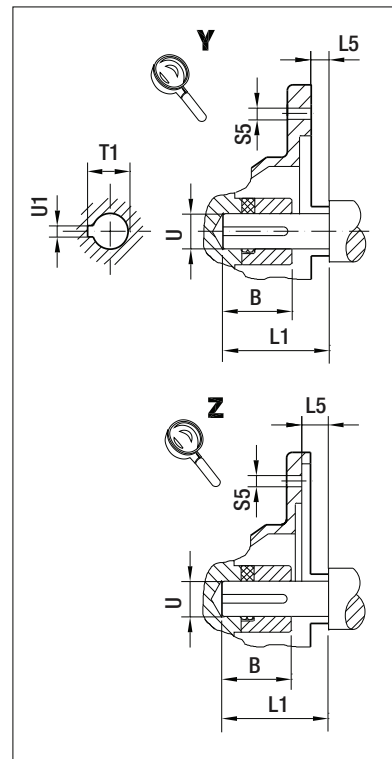
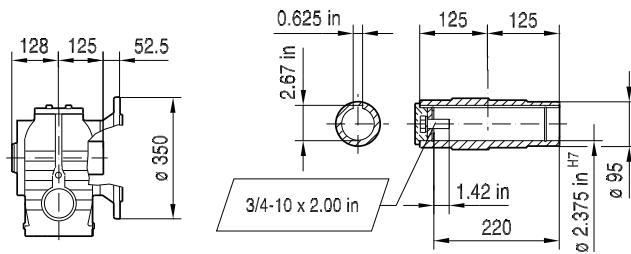

SHF87..

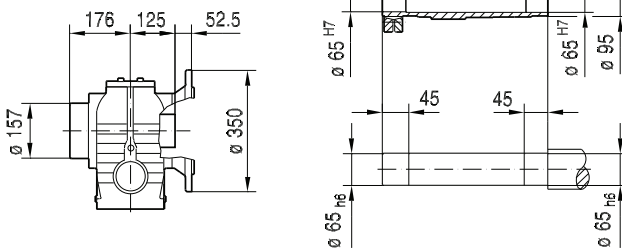

(→ 132)	B	B5	C5	E5	F5	G5	L	L1	L5	S5	T1	U	U1	Z5
AM143	1.68 in	4.50 in	12	5.875 in	4.5	170	439	2.25 in	0.13 in	10.5	0.98 in	0.875 in	0.188 in	98.5
AM145	1.68 in	4.50 in	12	5.875 in	4.5	170	439	2.25 in	0.13 in	10.5	0.98 in	0.875 in	0.188 in	98.5
AM182	2.10 in	8.50 in	10	7.25 in	5	228	475	2.75 in	0.13 in	15	1.24 in	1.125 in	0.250 in	134.5
AM184	2.10 in	8.50 in	10	7.25 in	5	228	475	2.75 in	0.13 in	15	1.24 in	1.125 in	0.250 in	134.5
AM213/215	2.76 in	8.50 in	11	7.25 in	5	228	524	3.38 in	0.25 in	15	1.52 in	1.375 in	0.312 in	183.5
AM254/256	3.65 in	8.50 in	14	7.25 in	5	228	574	4.00 in	0.25 in	15	1.80 in	1.625 in	0.375 in	234
AM284/286	4.00 in	10.50 in	15	9.00 in	5	286	581	4.62 in	0.25 in	15	2.10 in	1.875 in	0.500 in	241

Note: Dimensions in mm unless otherwise noted. For all available output shaft diameters, see page 682. For dimensions of compound gear units (ex: SF87R57) see page 648.

02 029 00 11

SA87..

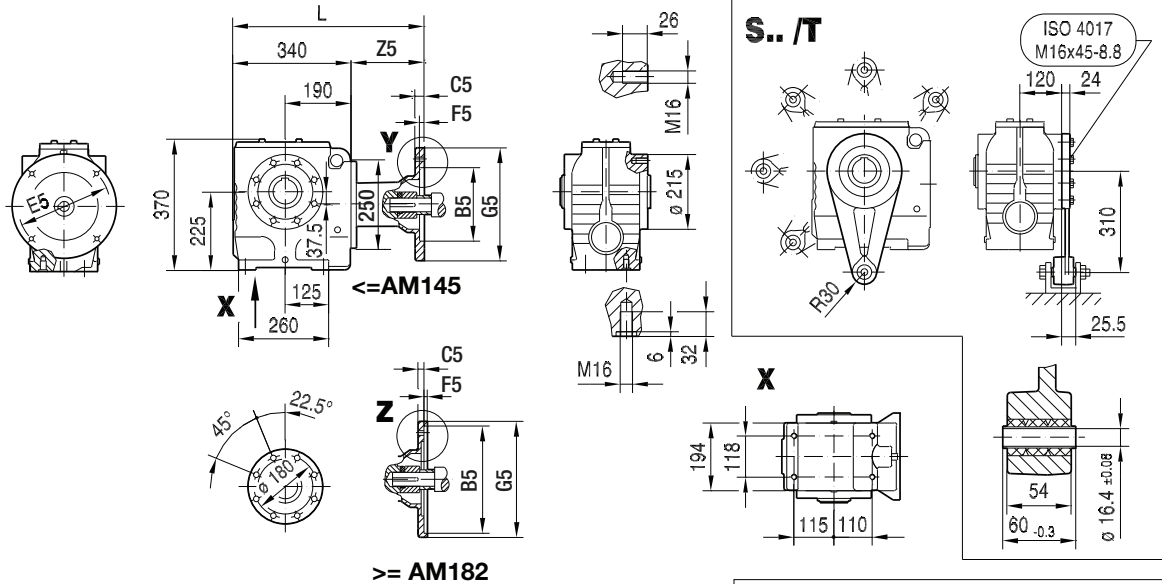

SA87..

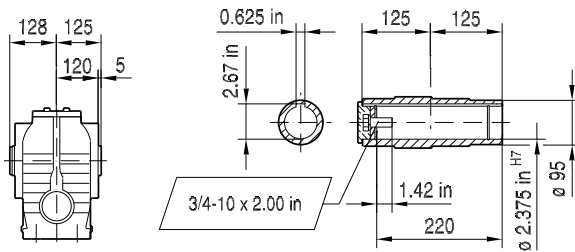

SH87..

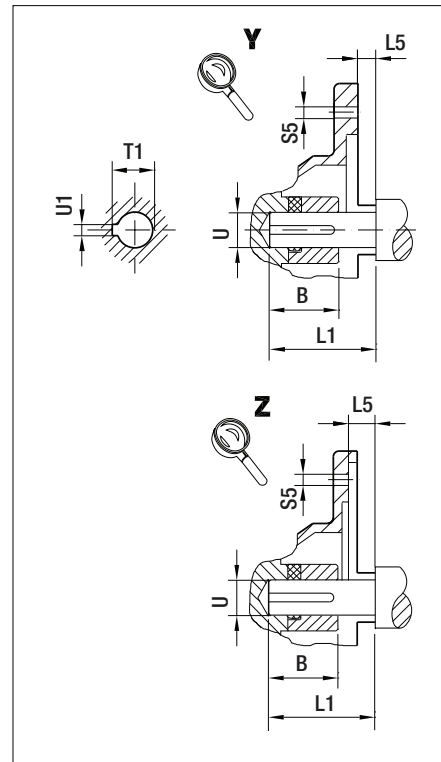
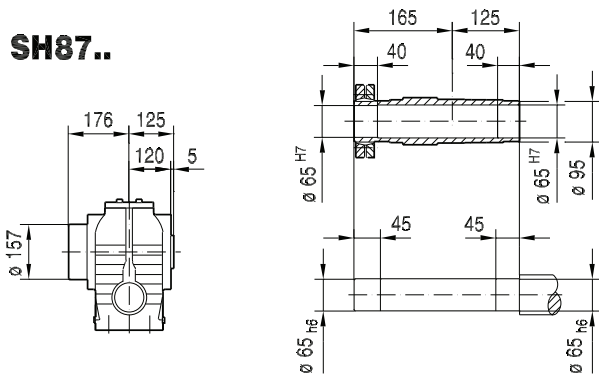

(→ 132)	B	B5	C5	E5	F5	G5	L	L1	L5	S5	T1	U	U1	Z5
AM143	1.68 in	4.50 in	12	5.875 in	4.5	170	439	2.25 in	0.13 in	10.5	0.98 in	0.875 in	0.188 in	98.5
AM145	1.68 in	4.50 in	12	5.875 in	4.5	170	439	2.25 in	0.13 in	10.5	0.98 in	0.875 in	0.188 in	98.5
AM182	2.10 in	8.50 in	10	7.25 in	5	228	475	2.75 in	0.13 in	15	1.24 in	1.125 in	0.250 in	134.5
AM184	2.10 in	8.50 in	10	7.25 in	5	228	475	2.75 in	0.13 in	15	1.24 in	1.125 in	0.250 in	134.5
AM213/215	2.76 in	8.50 in	11	7.25 in	5	228	524	3.38 in	0.25 in	15	1.52 in	1.375 in	0.312 in	183.5
AM254/256	3.65 in	8.50 in	14	7.25 in	5	228	574	4.00 in	0.25 in	15	1.80 in	1.625 in	0.375 in	234
AM284/286	4.00 in	10.50 in	15	9.00 in	5	286	581	4.62 in	0.25 in	15	2.10 in	1.875 in	0.500 in	241

Note: Dimensions in mm unless otherwise noted. For all available output shaft diameters, see page 684. For dimensions of compound gear units (ex: SA87R57) see page 648.

SAZ87..

02 030 00 11

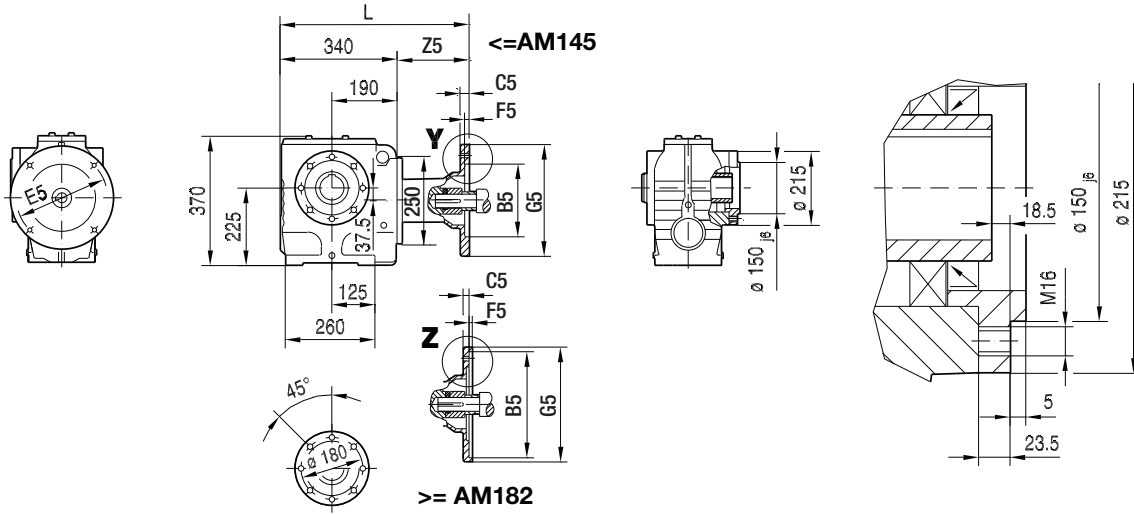

SAZ87..

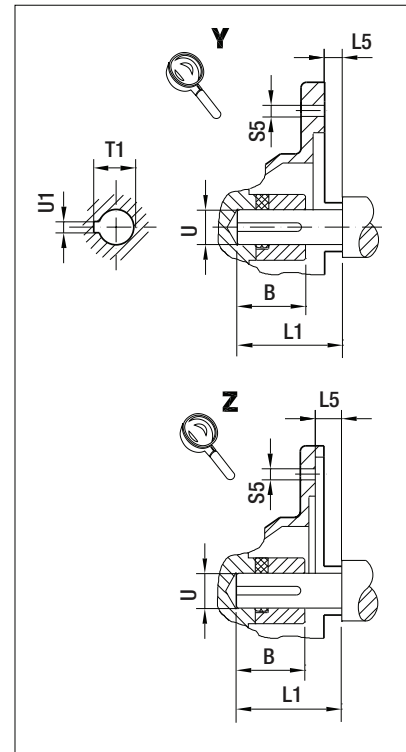
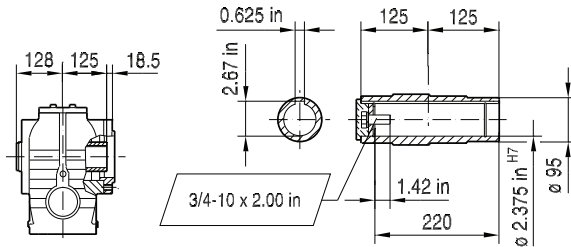

SHZ87..

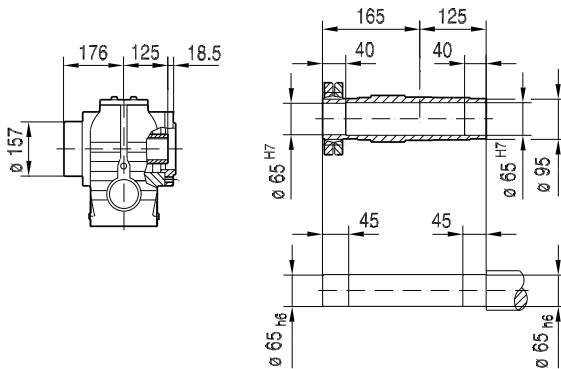

(→ 132)	B	B5	C5	E5	F5	G5	L	L1	L5	S5	T1	U	U1	Z5
AM143	1.68 in	4.50 in	12	5.875 in	4.5	170	439	2.25 in	0.13 in	10.5	0.98 in	0.875 in	0.188 in	98.5
AM145	1.68 in	4.50 in	12	5.875 in	4.5	170	439	2.25 in	0.13 in	10.5	0.98 in	0.875 in	0.188 in	98.5
AM182	2.10 in	8.50 in	10	7.25 in	5	228	475	2.75 in	0.13 in	15	1.24 in	1.125 in	0.250 in	134.5
AM184	2.10 in	8.50 in	10	7.25 in	5	228	475	2.75 in	0.13 in	15	1.24 in	1.125 in	0.250 in	134.5
AM213/215	2.76 in	8.50 in	11	7.25 in	5	228	524	3.38 in	0.25 in	15	1.52 in	1.375 in	0.312 in	183.5
AM254/256	3.65 in	8.50 in	14	7.25 in	5	228	574	4.00 in	0.25 in	15	1.80 in	1.625 in	0.375 in	234
AM284/286	4.00 in	10.50 in	15	9.00 in	5	286	581	4.62 in	0.25 in	15	2.10 in	1.875 in	0.500 in	241

Note: Dimensions in mm unless otherwise noted. For all available output shaft diameters, see page 684. For dimensions of compound gear units (ex: SAZ87R57) see page 648.

02 031 00 11

ST87..

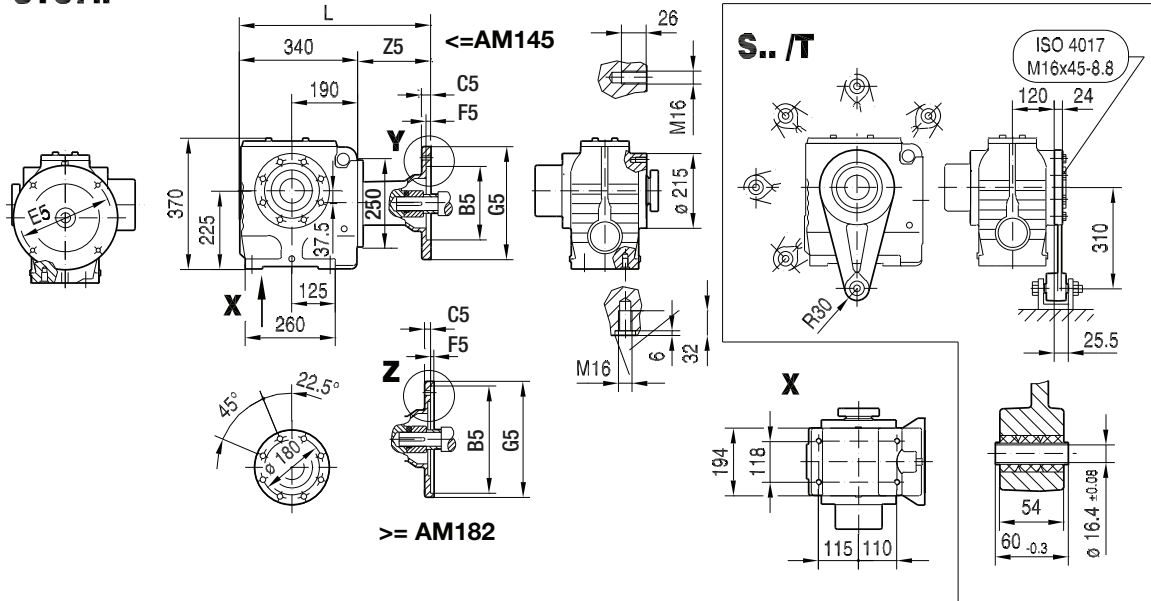

NON-Symmetrical

Symmetrical

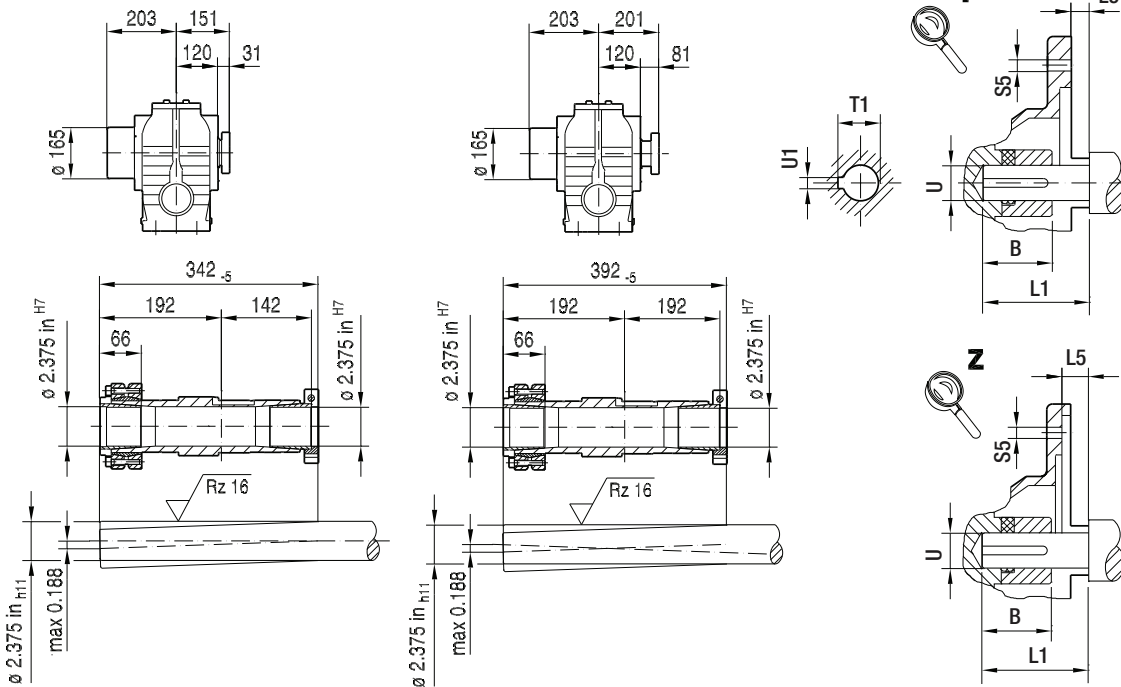

(→ 132)	B	B5	C5	E5	F5	G5	L	L1	L5	S5	T1	U	U1	Z5
AM143	1.68 in	4.50 in	12	5.875 in	4.5	170	439	2.25 in	0.13 in	10.5	0.98 in	0.875 in	0.188 in	98.5
AM145	1.68 in	4.50 in	12	5.875 in	4.5	170	439	2.25 in	0.13 in	10.5	0.98 in	0.875 in	0.188 in	98.5
AM182	2.10 in	8.50 in	10	7.25 in	5	228	475	2.75 in	0.13 in	15	1.24 in	1.125 in	0.250 in	134.5
AM184	2.10 in	8.50 in	10	7.25 in	5	228	475	2.75 in	0.13 in	15	1.24 in	1.125 in	0.250 in	134.5
AM213/215	2.76 in	8.50 in	11	7.25 in	5	228	524	3.38 in	0.25 in	15	1.52 in	1.375 in	0.312 in	183.5
AM254/256	3.65 in	8.50 in	14	7.25 in	5	228	574	4.00 in	0.25 in	15	1.80 in	1.625 in	0.375 in	234
AM284/286	4.00 in	10.50 in	15	9.00 in	5	286	581	4.62 in	0.25 in	15	2.10 in	1.875 in	0.500 in	241

Note: Dimensions in mm unless otherwise noted. For all available output shaft diameters, see page 686. For dimensions of compound gear units (ex: ST87R57) see page 648.

02 032 00 11

S97..

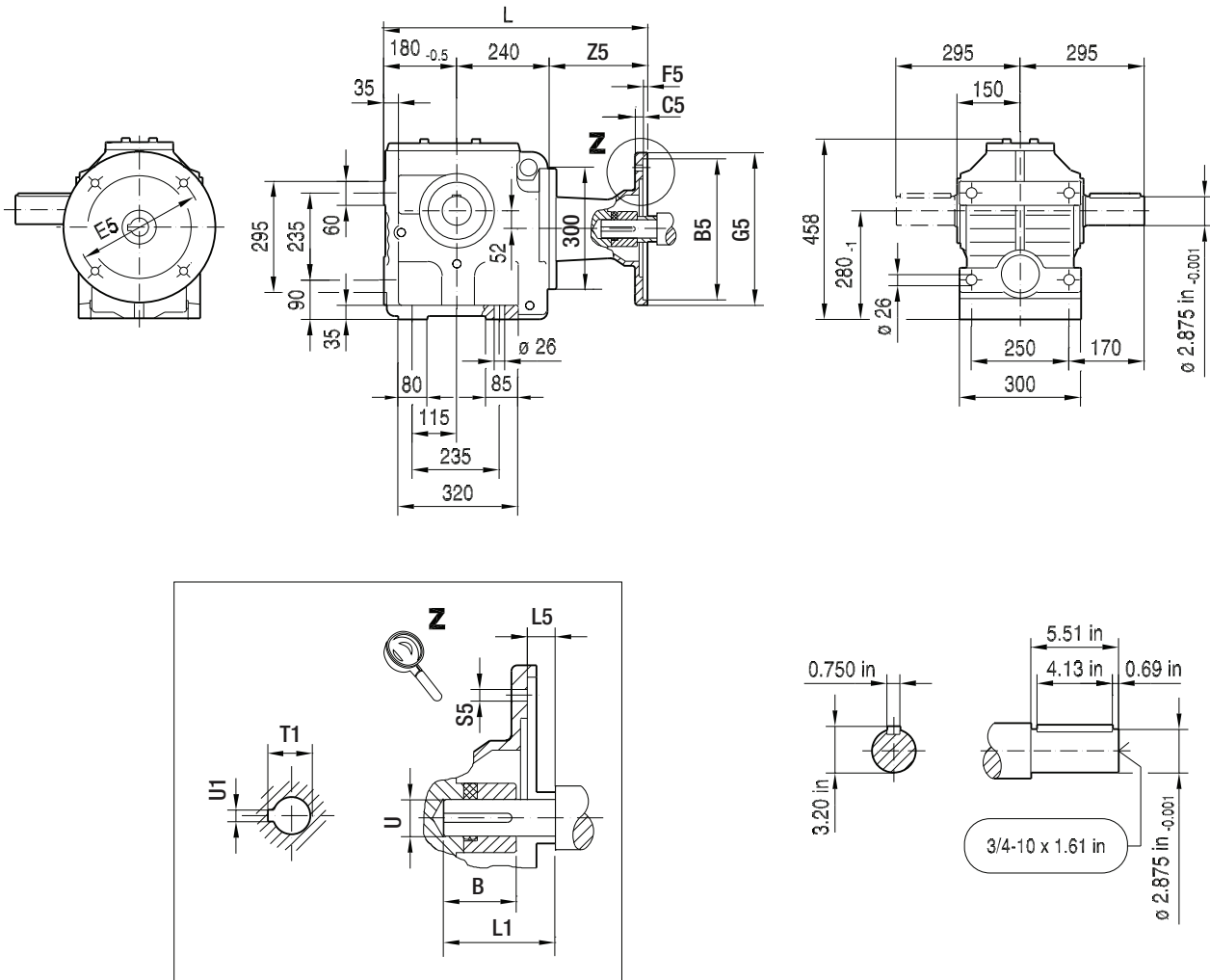

11

(→ 132)	B	B5	C5	E5	F5	G5	L	L1	L5	S5	T1	U	U1	Z5
AM182	2.10 in	8.50 in	10	7.25 in	5	228	550	2.75 in	0.13 in	15	1.24 in	1.125 in	0.250 in	129.5
AM184	2.10 in	8.50 in	10	7.25 in	5	228	550	2.75 in	0.13 in	15	1.24 in	1.125 in	0.250 in	129.5
AM213/215	2.76 in	8.50 in	11	7.25 in	5	228	599	3.38 in	0.25 in	15	1.52 in	1.375 in	0.312 in	178.5
AM254/256	3.65 in	8.50 in	12	7.25 in	5	228	649	4.00 in	0.25 in	15	1.80 in	1.625 in	0.375 in	229
AM284/286	4.00 in	10.50 in	15	9.00 in	5	286	656	4.62 in	0.25 in	15	2.10 in	1.875 in	0.500 in	236
AM324/326	3.88 in	12.50 in	17	11.0 in	5	356	716	5.25 in	0.25 in	17.5	2.36 in	2.125 in	0.500 in	296
AM364/365	4.51 in	12.50 in	17	11.0 in	5	356	716	5.88 in	0.25 in	17.5	2.66 in	2.375 in	0.625 in	296

Note: Dimensions in mm unless otherwise noted. For all available output shaft diameters, see page 682. For dimensions of compound gear units (ex: S97R57) see page 648.

02 033 00 11

SF97..

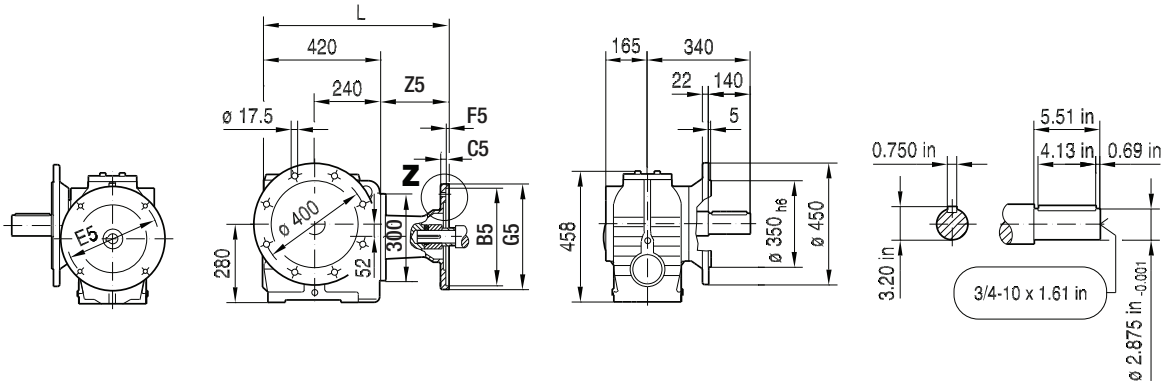

SAF97..

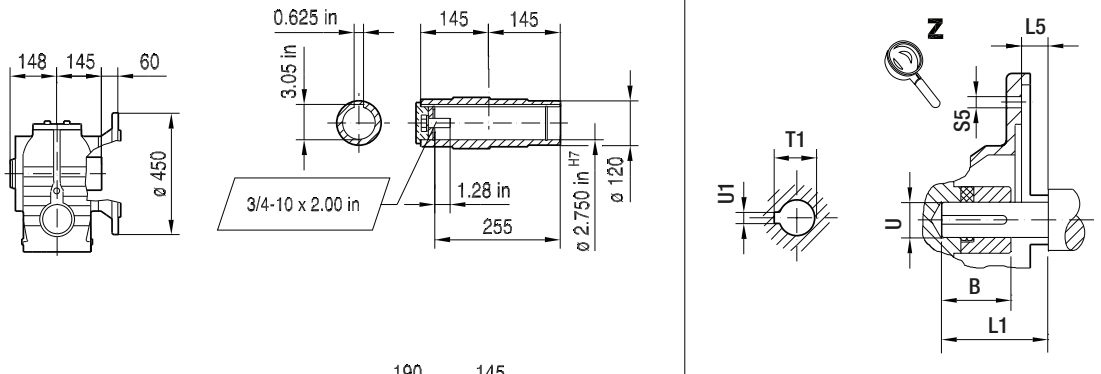

SHF97..

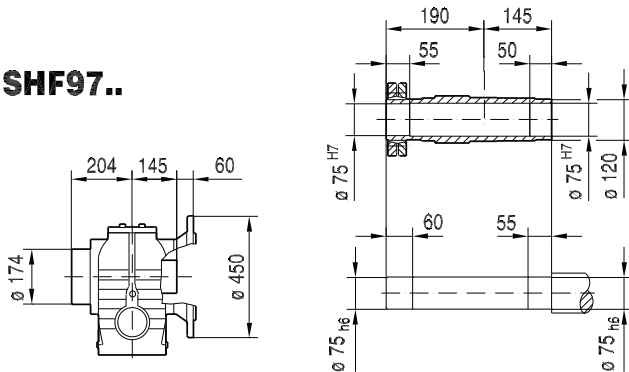

(→ 132)	B	B5	C5	E5	F5	G5	L	L1	L5	S5	T1	U	U1	Z5
AM182	2.10 in	8.50 in	10	7.25 in	5	228	550	2.75 in	0.13 in	15	1.24 in	1.125 in	0.250 in	129.5
AM184	2.10 in	8.50 in	10	7.25 in	5	228	550	2.75 in	0.13 in	15	1.24 in	1.125 in	0.250 in	129.5
AM213/215	2.76 in	8.50 in	11	7.25 in	5	228	599	3.38 in	0.25 in	15	1.52 in	1.375 in	0.312 in	178.5
AM254/256	3.65 in	8.50 in	12	7.25 in	5	228	649	4.00 in	0.25 in	15	1.80 in	1.625 in	0.375 in	229
AM284/286	4.00 in	10.50 in	15	9.00 in	5	286	656	4.62 in	0.25 in	15	2.10 in	1.875 in	0.500 in	236
AM324/326	3.88 in	12.50 in	17	11.0 in	5	356	716	5.25 in	0.25 in	17.5	2.36 in	2.125 in	0.500 in	296
AM364/365	4.51 in	12.50 in	17	11.0 in	5	356	716	5.88 in	0.25 in	17.5	2.66 in	2.375 in	0.625 in	296

Note: Dimensions in mm unless otherwise noted. For all available output shaft diameters, see page 682. For dimensions of compound gear units (ex: SF97R57) see page 648.

02 034 00 11

SA97..

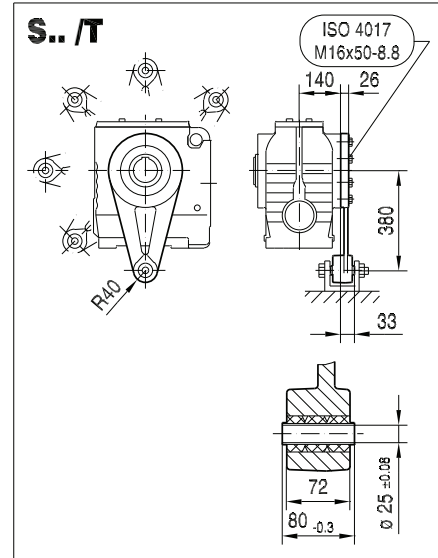
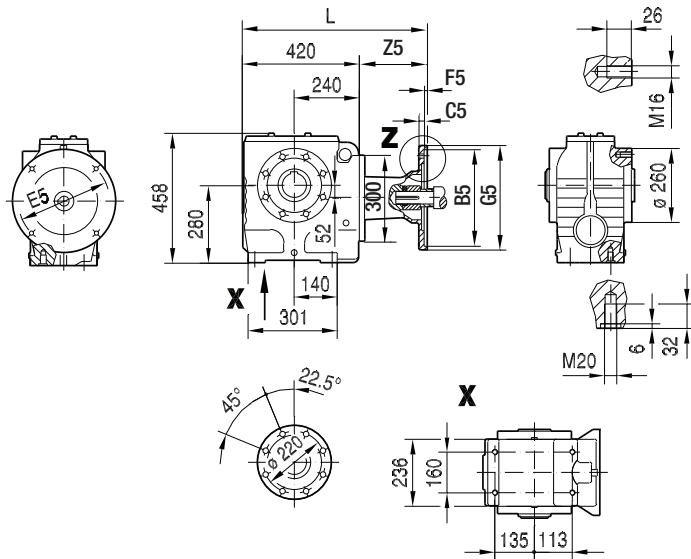

SA97..

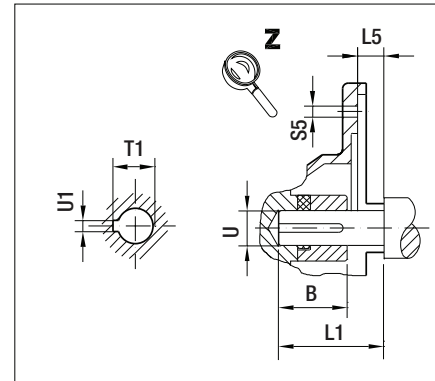
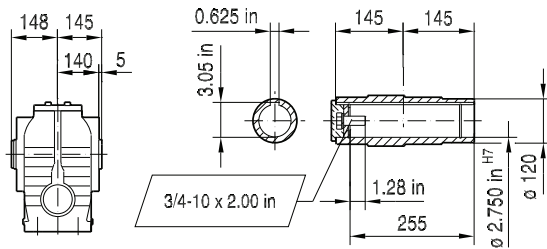

SH97..

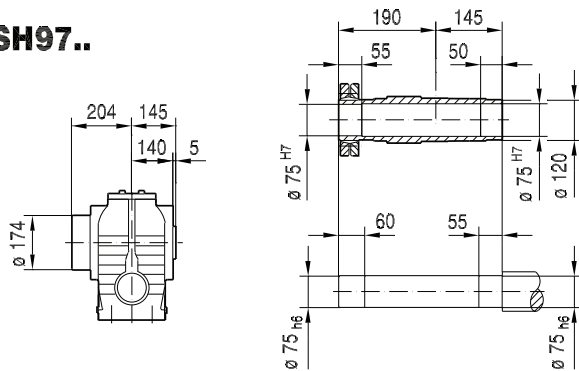

(→ 132)	B	B5	C5	E5	F5	G5	L	L1	L5	S5	T1	U	U1	Z5
AM182	2.10 in	8.50 in	10	7.25 in	5	228	550	2.75 in	0.13 in	15	1.24 in	1.125 in	0.250 in	129.5
AM184	2.10 in	8.50 in	10	7.25 in	5	228	550	2.75 in	0.13 in	15	1.24 in	1.125 in	0.250 in	129.5
AM213/215	2.76 in	8.50 in	11	7.25 in	5	228	599	3.38 in	0.25 in	15	1.52 in	1.375 in	0.312 in	178.5
AM254/256	3.65 in	8.50 in	12	7.25 in	5	228	649	4.00 in	0.25 in	15	1.80 in	1.625 in	0.375 in	229
AM284/286	4.00 in	10.50 in	15	9.00 in	5	286	656	4.62 in	0.25 in	15	2.10 in	1.875 in	0.500 in	236
AM324/326	3.88 in	12.50 in	17	11.0 in	5	356	716	5.25 in	0.25 in	17.5	2.36 in	2.125 in	0.500 in	296
AM364/365	4.51 in	12.50 in	17	11.0 in	5	356	716	5.88 in	0.25 in	17.5	2.66 in	2.375 in	0.625 in	296

Note: Dimensions in mm unless otherwise noted. For all available output shaft diameters, see page 684. For dimensions of compound gear units (ex: SA97R57) see page 648.

SAZ97..

02 035 00 11

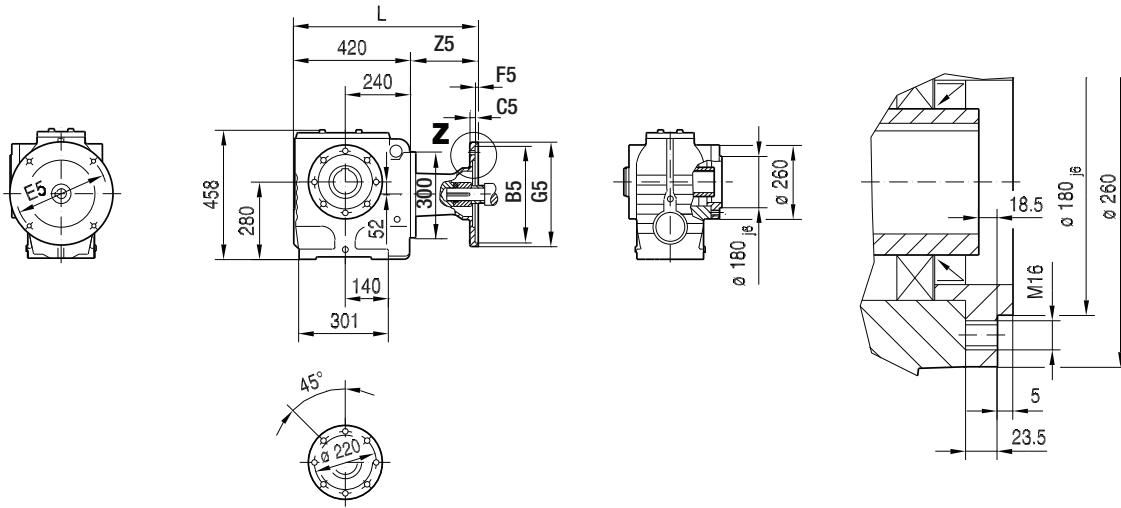

SAZ97..

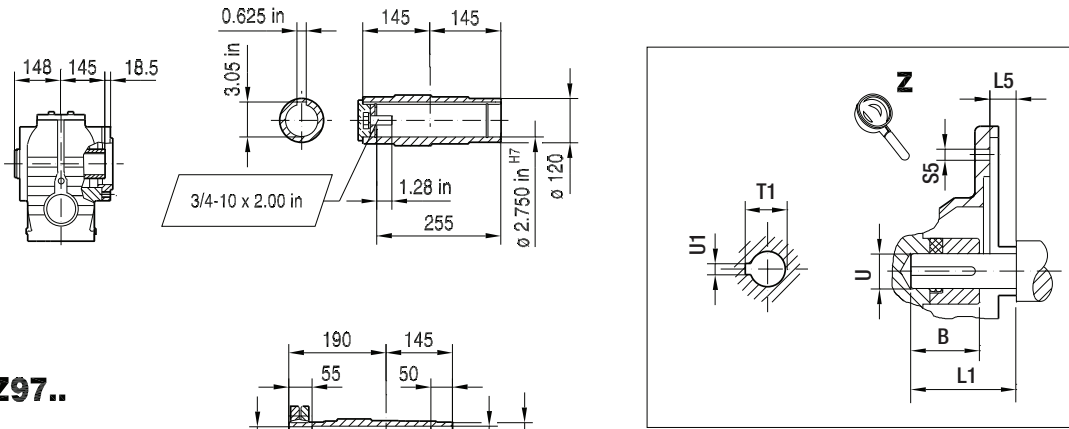

SHZ97..

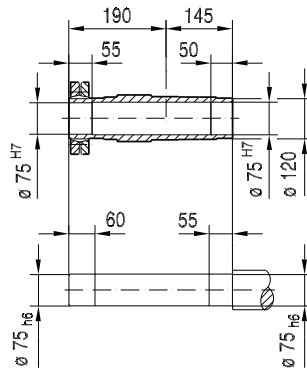
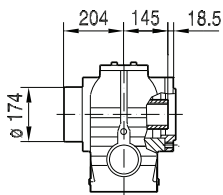

(→ 132)	B	B5	C5	E5	F5	G5	L	L1	L5	S5	T1	U	U1	Z5
AM182	2.10 in	8.50 in	10	7.25 in	5	228	550	2.75 in	0.13 in	15	1.24 in	1.125 in	0.250 in	129.5
AM184	2.10 in	8.50 in	10	7.25 in	5	228	550	2.75 in	0.13 in	15	1.24 in	1.125 in	0.250 in	129.5
AM213/215	2.76 in	8.50 in	11	7.25 in	5	228	599	3.38 in	0.25 in	15	1.52 in	1.375 in	0.312 in	178.5
AM254/256	3.65 in	8.50 in	12	7.25 in	5	228	649	4.00 in	0.25 in	15	1.80 in	1.625 in	0.375 in	229
AM284/286	4.00 in	10.50 in	15	9.00 in	5	286	656	4.62 in	0.25 in	15	2.10 in	1.875 in	0.500 in	236
AM324/326	3.88 in	12.50 in	17	11.0 in	5	356	716	5.25 in	0.25 in	17.5	2.36 in	2.125 in	0.500 in	296
AM364/365	4.51 in	12.50 in	17	11.0 in	5	356	716	5.88 in	0.25 in	17.5	2.66 in	2.375 in	0.625 in	296

Note: Dimensions in mm unless otherwise noted. For all available output shaft diameters, see page 684. For dimensions of compound gear units (ex: SAZ97R57) see page 648.

02 036 00 11

ST97..

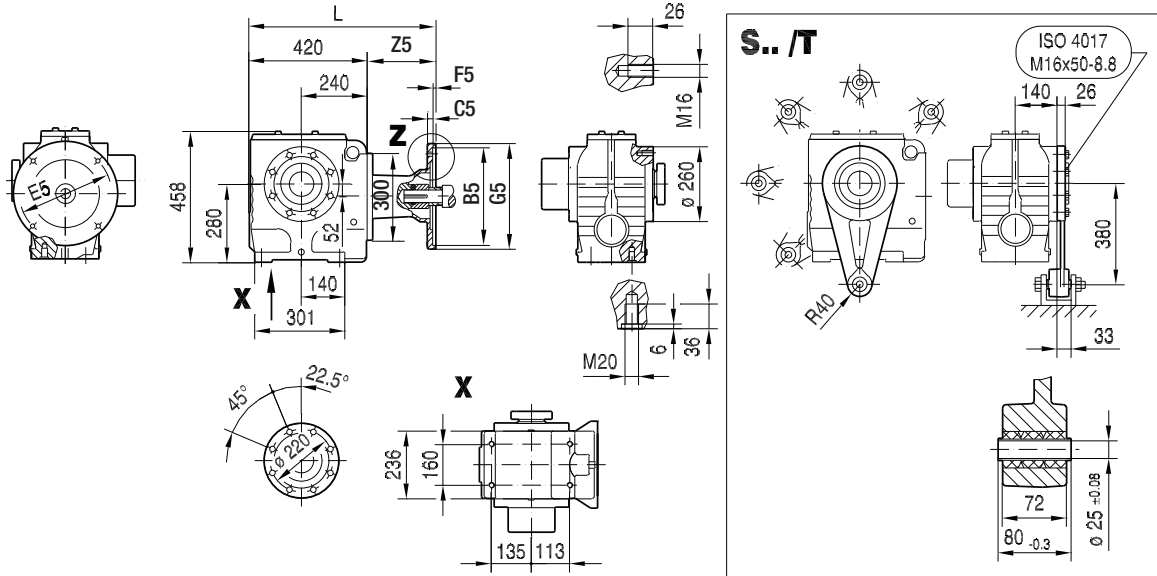

NON-Symmetrical

Symmetrical

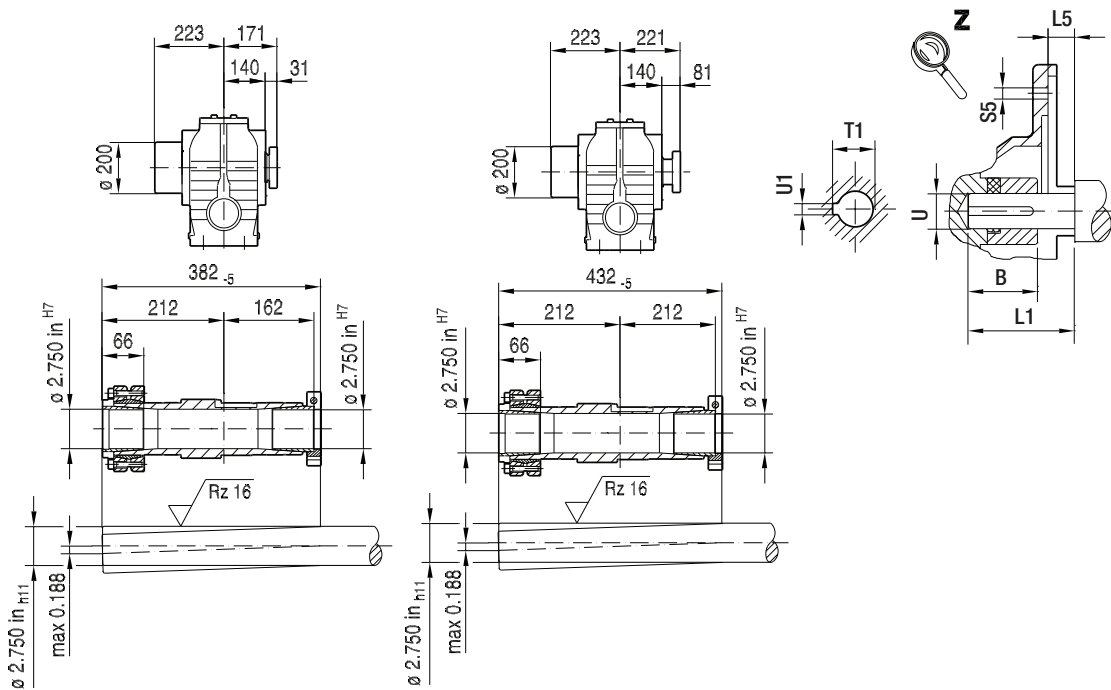

11

(→ 132)	B	B5	C5	E5	F5	G5	L	L1	L5	S5	T1	U	U1	Z5
AM182	2.10 in	8.50 in	10	7.25 in	5	228	550	2.75 in	0.13 in	15	1.24 in	1.125 in	0.250 in	129.5
AM184	2.10 in	8.50 in	10	7.25 in	5	228	550	2.75 in	0.13 in	15	1.24 in	1.125 in	0.250 in	129.5
AM213/215	2.76 in	8.50 in	11	7.25 in	5	228	599	3.38 in	0.25 in	15	1.52 in	1.375 in	0.312 in	178.5
AM254/256	3.65 in	8.50 in	12	7.25 in	5	228	649	4.00 in	0.25 in	15	1.80 in	1.625 in	0.375 in	229
AM284/286	4.00 in	10.50 in	15	9.00 in	5	286	656	4.62 in	0.25 in	15	2.10 in	1.875 in	0.500 in	236
AM324/326	3.88 in	12.50 in	17	11.0 in	5	356	716	5.25 in	0.25 in	17.5	2.36 in	2.125 in	0.500 in	296
AM364/365	4.51 in	12.50 in	17	11.0 in	5	356	716	5.88 in	0.25 in	17.5	2.66 in	2.375 in	0.625 in	296

Note: Dimensions in mm unless otherwise noted. For all available output shaft diameters, see page 686. For dimensions of compound gear units (ex: ST97R57) see page 648.

11.4 S.. AM.. [IEC dimensions]

23 002 100

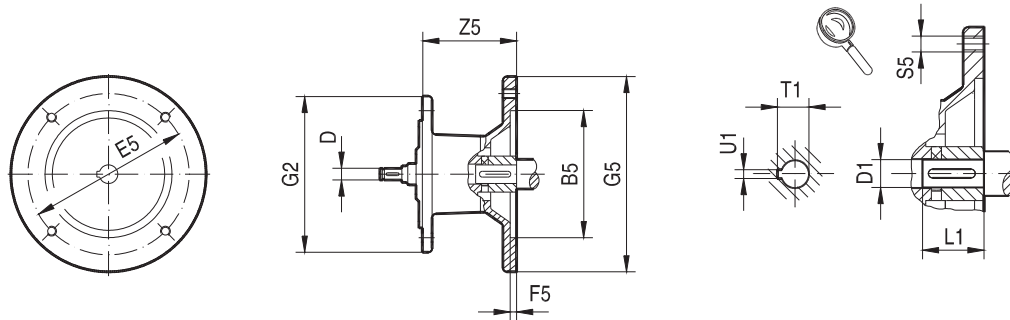

		Dimensions in mm											
		B5	D	E5	F5	G2	G5	S5	Z5	D1	L1	T1	U1
S..37 S..47 S..57	AM63	95	10	115	3.5	120	140	M8	72	11	23	12.8	4
	AM71 ¹⁾	110		130	4		160			14	30	16.3	5
	AM80 ¹⁾	130	12	165	4.5		200	M10	106	19	40	21.8	6
	AM90 ¹⁾		14							24	50	27.3	8
S..67	AM63	95	10	115	3.5	160	140	M8	66	11	23	12.8	4
	AM71	110		130	4		160			14	30	16.3	5
	AM80	130	12	165	4.5		200	M10	99	19	40	21.8	6
	AM90		14							24	50	27.3	8
	AM100 ¹⁾	180	16	215	5		250	M12	134	28	60	31.3	8
	AM112 ¹⁾		18							300	191	38	80
	AM132S/M ¹⁾	230	22	265									
		230	28	265									
S..77	AM63	95	10	115	3.5	200	140	M8	60	11	23	12.8	4
	AM71	110		130	4		160			14	30	16.3	5
	AM80	130	12	165	4.5		200	M10	92	19	40	21.8	6
	AM90		14							24	50	27.3	8
	AM100 ¹⁾	180	16	215	5		250	M12	126	28	60	31.3	8
	AM112 ¹⁾		18							300	179	38	80
	AM132S/M ¹⁾	230	22	265									
AM132ML ¹⁾		28	265										
S..87 ²⁾	AM80	130	12	165	4.5	250	200	M10	87	19	40	21.8	6
	AM90		14							24	50	27.3	8
	AM100	180	16	215	5		250	M12	121	28	60	31.3	8
	AM112		18							300	174	38	80
	AM132S/M	230	22	265	5		250	M12	121	28	60	31.3	8
	AM132ML		28							300	174	38	80
	AM160 ¹⁾	250	28	300	6		250	M16	232	42	110	45.3	12
AM180 ¹⁾	32		48			51.8				14			

1) Check dimension (G5)/2 as adapter may protrude past the bottom of the feet on a foot-mounted gear unit.

2) Not with AM180

23 003 100

Fig.1

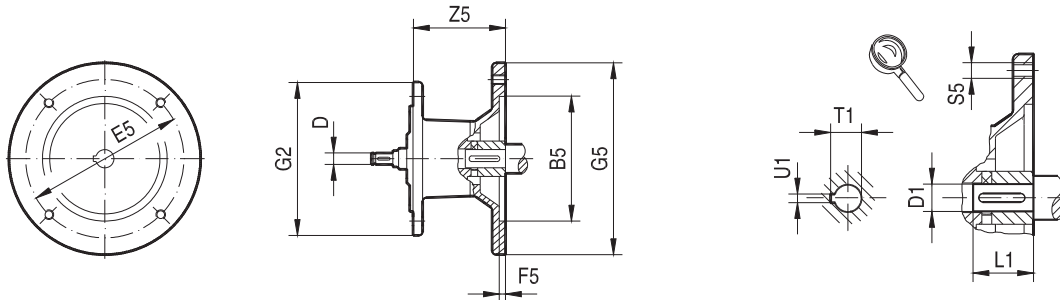

Fig.2

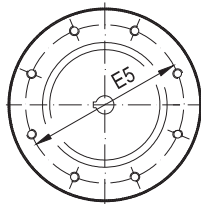
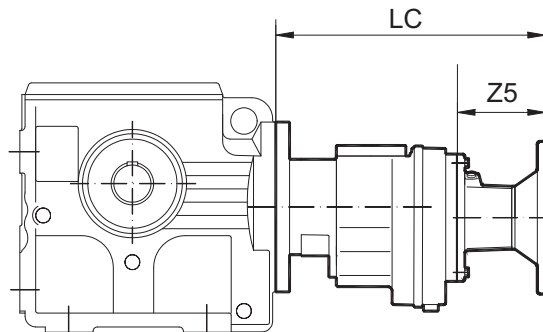

		Fig.	Dimensions in mm											
			B5	D	E5	F5	G2	G5	S5	Z5	D1	L1	T1	U1
S..97 ¹⁾	AM100	1	180	16	215	5	300	250	M12	116	28	60	31.3	8
	AM112			18										
	AM132S/M		230	22	265	6		350	M16	227	42	110	45.3	12
	AM132ML			28										
	AM160		250	28	300	7		400	M16	268	55	110	51.8	14
	AM180			32										
	AM200		300	38	350									59.3

1) Not with AM200

11.5 S.. R.. AM.. [compound dimensions]

S_R_AM

Large Unit	Small Unit	Adapter	Z5	LC
S..67	R37	AM56	93.5	258.5
		AM143	117	282
		AM145	117	282
S..77	R37	AM56	93.5	250.5
		AM143	117	274
		AM145	117	274
S...87	R57	AM56	87	303
		AM143	110.5	326.5
		AM145	110.5	326.5
		AM182	147.5	363.5
		AM184	147.5	363.5
		AM213/215	200.5	416.5
S..97	R57	AM56	87	298
		AM143	110.5	321.5
		AM145	110.5	321.5
		AM182	147.5	358.5
		AM184	147.5	358.5
		AM213/215	200.5	411.5

11.6 S.. AD.. [dimensions]

11.6.1 Input shaft - Inch

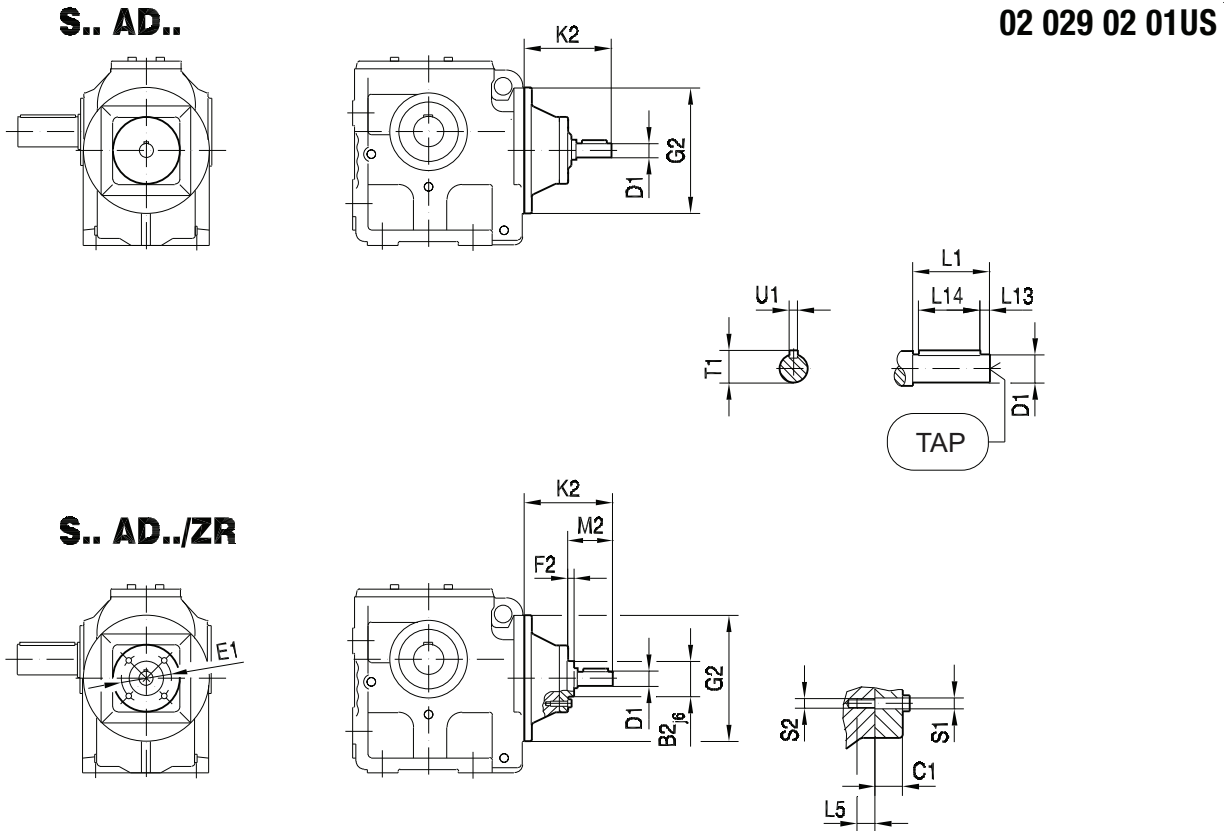

		B2	C1	D1	E1	F2	G2	K2	L1	L5	L13	L14	M2	S1	S2	T1	U1	TAP (inch)
S..37 S..47 S..57	AD1	-	-	0.625 in	-	-	120	102	40	-	4	32	-	-	-	0.70 in	0.1875 in	1/4-20 x0.63
	AD2	55	13.5	0.750 in	80	8		130	40	12	4	32	50	9	M8	0.83 in		
	AD3	70	15.5	0.875 in	105	8		159	50	16	5	40	60	11	M10	0.96 in		
S..67	AD2	55	13.5	0.750 in	80	8	160	116	40	12	4	32	50	9	M8	0.83 in	0.1875 in	1/4-20 x0.63
	AD3	70	15.5	0.875 in	105	8		116	40	12	4	32	50	9	M8	0.83 in		
	AD4	100	16	1.375 in	130	13		224	80	20	5	70	95.5	13.5	M12	1.51 in		
S..77	AD2	55	13.5	0.750 in	80	8	200	111	40	12	4	32	50	9	M8	0.83 in	0.1875 in	1/4-20 x0.63
	AD3	70	15.5	0.875 in	105	8		156	60	16	5	50	70	11	M10	0.96 in		
	AD4	100	16	1.375 in	130	13		219	80	20	5	70	95.5	13.5	M12	1.51 in		
	AD5	120	24	1.625 in	180	11		292	110	20	10	70	126	13.5	M12	1.79 in		
S..87	AD3	70	15.5	0.875 in	105	8	250	151	60	16	5	50	70	11	M10	0.96 in	0.1875 in	5/16-18 x0.87
	AD4	100	16	1.375 in	130	13		214	80	20	5	70	95.5	13.5	M12	1.51 in		
	AD5	120	24	1.625 in	180	11		287	110	20	10	70	126	13.5	M12	1.79 in		
	AD6	130	22.5	1.875 in	200	11		327	110	26	10	80	130.5	17.5	M16	2.09 in		
S..97	AD3	70	15.5	0.875 in	105	8	300	151	60	16	5	50	70	11	M10	0.96 in	0.1875 in	5/16-18 x0.87
	AD4	100	16	1.375 in	130	13		214	80	20	5	70	95.5	13.5	M12	1.51 in		
	AD5	120	24	1.625 in	180	11		287	110	20	10	70	126	13.5	M12	1.79 in		
	AD6	130	22.5	1.875 in	200	11		327	110	26	10	80	130.5	17.5	M16	2.09 in		

11.6.2 Input shaft - Metric

S.. AD..

02 029 02 01

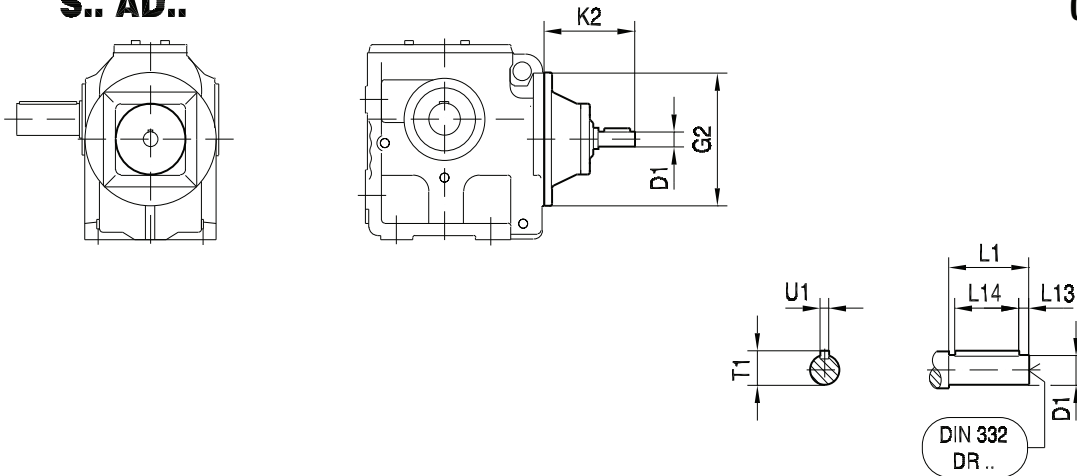

S.. AD../ZR

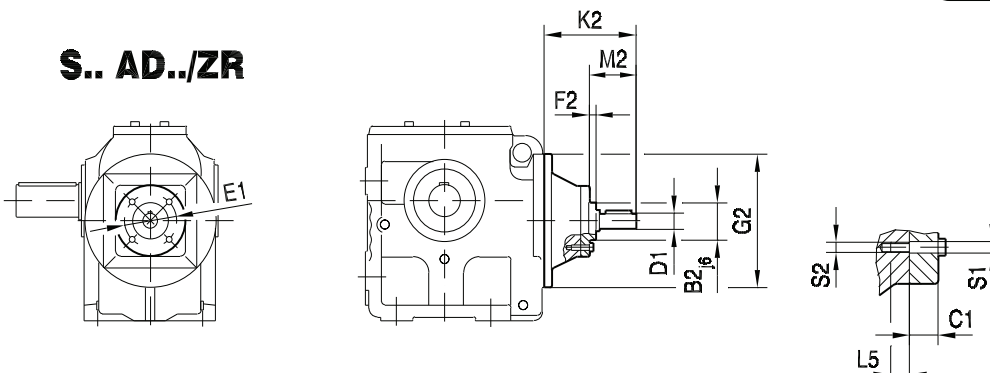

		B2	C1	E1	F2	G2	K2	L5	M2	S1	S2	D1	L1	L13	L14	T1	U1
S..37 S..47 S..57	AD1	-	-	-	-	120	102	-	-	-	-	16	40	4	32	18	5
	AD2, AD2/ZR	55	13.5	80	8		130	12	50	9	M8	19	40	4	32	21.5	6
S..67	AD2, AD2/ZR	55	13.5	80	8	160	123	12	50	9	M8	19	40	4	32	21.5	6
	AD3, AD3/ZR	70	15.5	105	8		159	16	60	11	M10	24	50	5	40	27	8
S..77	AD2, AD2/ZR	55	13.5	80	8	200	116	12	50	9	M8	19	40	4	32	21.5	6
	AD3, AD3/ZR	70	15.5	105	8		151	16	60	11	M10	24	50	5	40	27	8
	AD4, AD4/ZR	100	16	130	13		224	20	95.5	13.5	M12	38	80	5	70	41	10
S..87	AD2, AD2/ZR	55	13.5	80	8	250	111	12	50	9	M8	19	40	4	32	21.5	6
	AD3, AD3/ZR	70	15.5	105	8		156	16	70	11	M10	28	60	5	50	31	8
	AD4, AD4/ZR	100	16	130	13		219	20	95.5	13.5	M12	38	80	5	70	41	10
	AD5, AD5/ZR	120	24	180	11		292	20	126	13.5	M12	42	110	10	70	45	12
S..97	AD3, AD3/ZR	70	15.5	105	8	300	151	16	70	11	M10	28	60	5	50	31	8
	AD4, AD4/ZR	100	16	130	13		214	20	95.5	13.5	M12	38	80	5	70	41	10
	AD5, AD5/ZR	120	24	180	11		287	20	126	13.5	M12	42	110	10	70	45	12
	AD6, AD6/ZR	130	22.5	200	11		327	26	130.5	17.5	M16	48	110	10	80	51.5	14

11.7 S.. R.. AD.. [compound dimensions]

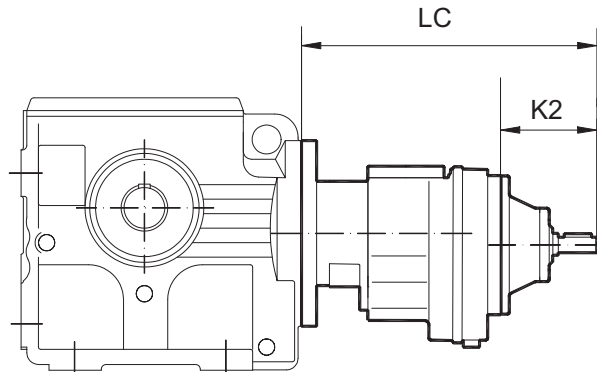

S_R_AD

Large Unit	Small Unit	Adapter	K2	LC
S..67	R37	AD1	102	267
		AD2	130	295
S..77	R37	AD1	102	259
		AD2	130	287
S..87	R57	AD2	123	339
		AD3	159	375
S..97	R57	AD2	123	334
		AD3	159	370

11.8 S.. AD../P [dimensions]

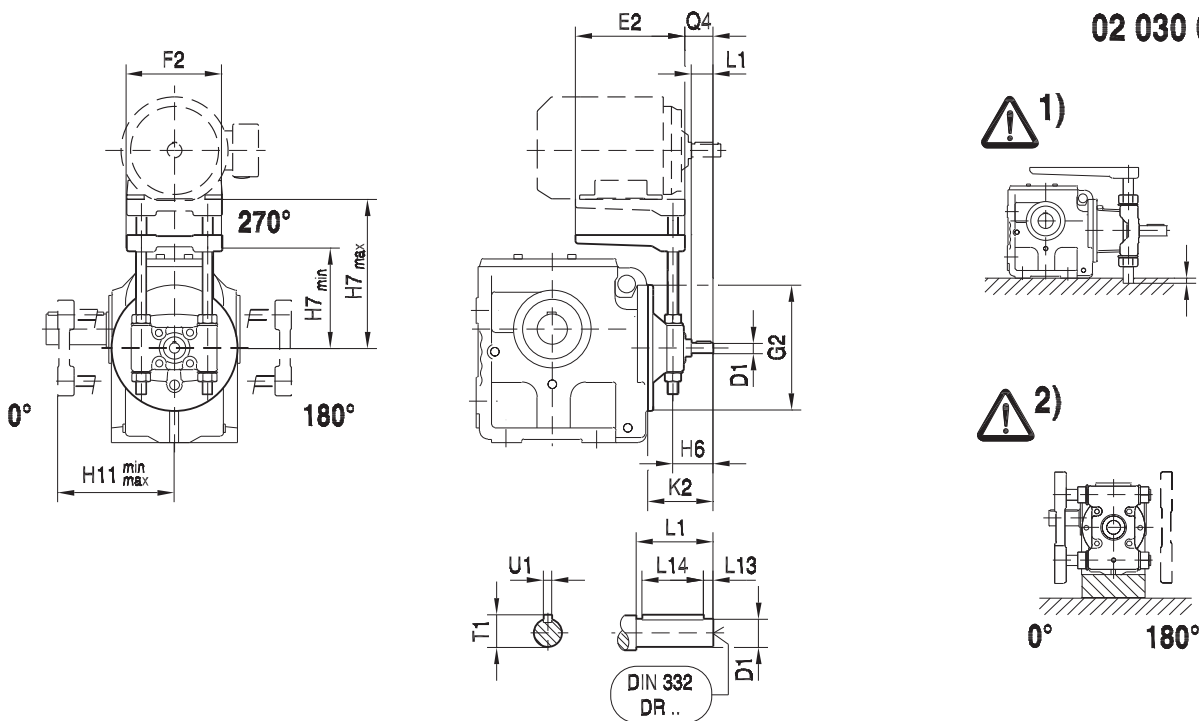

		E2	F2	G2	H6	H7 min	H7 max	H11 min	H11 max	K2	Q4	D1	L1	L13	L14	T1	U1	⚠ →131
S..37	AD2/P	195	180	120	65	110	165	95	165	130	43	19	40	4	32	21.5	6	1), 2)
S..47																		
S..67	AD2/P	195	180	160	65	140	200	110	165	123	43	19	40	4	32	21.5	6	1)
	AD3/P	230	240		80	145	175	130	175	159	54	24	50	5	40	27	8	2)
S..77	AD2/P	195	180	200	65	175	260	145	200	116	43	19	40	4	32	21.5	6	
	AD3/P	230	240		80	180	230	150	230	151	54	24	50	5	40	27	8	
	AD4/P	345	291		118	190	280	150	210	224	83	38	80	5	70	41	10	1)
S..87	AD2/P	195	180	250	65	215	260	165	200	111	43	19	40	4	32	21.5	6	
	AD3/P	230	240		90	230	320	170	230	156	64	28	60	5	50	31	8	
	AD4/P	345	291		118	250	360	170	210	219	83	38	80	5	70	41	10	1)
	AD5/P	430	355		153	260	325	185	250	292	113	42	110	10	70	45	12	1), 2)
S..97	AD3/P	230	240	300	90	275	320	190	230	151	64	28	60	5	50	31	8	
	AD4/P	345	291		118	305	360	190	280	214	83	38	80	5	70	41	10	
	AD5/P	430	355		153	315	405	200	250	287	113	42	110	10	70	45	12	

11.9 S.. AR.. [dimensions]

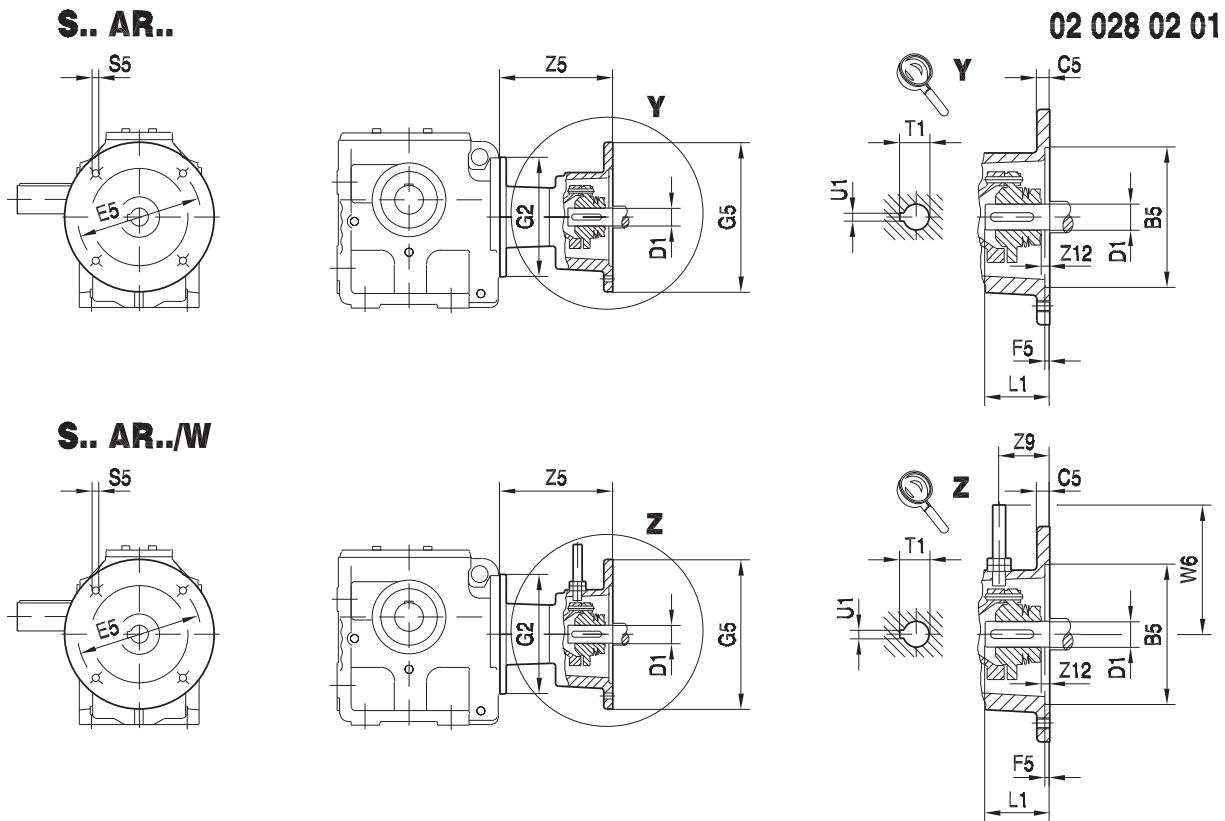

		B5	C5	E5	F5	G2	G5	S5	W6	Z5	Z9	Z12	D1	L1	T1	U1			
S..37	AR71	110	10	130	3.5	120	160	M8	120	104	37	0	14	30	16.3	5			
S..47	AR80	130	12	165	4.5		200	M10		140.5			19	40	21.8	6			
S..57	AR90						24	50		27.3			8						
S..67	AR71	110	10	130	3.5	160	160	M8	120	97.5	37	0	14	30	16.3	5			
	AR80	130	12	165	4.5		200	M10		134			19	40	21.8	6			
	AR90						24	50		27.3			8						
	AR100	180	15	215	5		250	M12		130			174.5	52	5.5	28	60	31.3	8
	AR112	230	16	265	5		300	M12		145			234	72	5	38	80	41.3	10
AR132S/M	AR132ML																		
S..77	AR71	110	10	130	3.5	200	160	M8	120	91.5	37	0	14	30	16.3	5			
	AR80	130	12	165	4.5		200	M10		127			19	40	21.8	6			
	AR90						24	50		27.3			8						
	AR100	180	15	215	5		250	M12		130			166.5	52	5.5	28	60	31.3	8
	AR112	230	16	265	5		300	M12		145			229	72	5	38	80	41.3	10
AR132S/M	AR132ML																		
S..87	AR80	130	12	165	4.5	250	200	M10	120	122	37	0	19	40	21.8	6			
	AR90												24	50	27.3	8			
	AR100	180	15	215	5		250	M12	130	161.5	52	5.5	28	60	31.3	8			
	AR112	230	16	265	5		300	M12	145	229	72	5	38	80	41.3	10			
	AR132S/M																AR132ML		
	AR160	250	18	300	6		350	M16	165	306.5	105	35	42	110	45.3	12			
AR180	48					110							51.8	14					
S..97	AR100	180	15	215	5	300	250	M12	130	156.5	52	5.5	28	60	31.3	8			
	AR112	230	16	265	5		300	M12	145	224	72	5	38	80	41.3	10			
	AR132S/M																AR132ML		
	AR160	250	18	300	6		350	M16	165	301.5	105	35	42	110	45.3	12			
	AR180												48	110	51.8	14			

11.10 Mechanical ratings

11.10.1 S37

3400 - 2800 rpm

02 955 197

S37													
i [ratio]	Worm ratio/ # starts	$n_e = 3400$ rpm				$n_e = 3200$ rpm				$n_e = 2800$ rpm			
		n_a [rpm]	T_{amax} [lb-in]	P_e [HP]	η [%]	n_a [rpm]	T_{amax} [lb-in]	P_e [HP]	η [%]	n_a [rpm]	T_{amax} [lb-in]	P_e [HP]	η [%]
157.43	38/1	22	690	0.42	57	20	710	0.40	57	18	725	0.36	57
144.40		24	675	0.44	58	22	690	0.42	58	19	710	0.38	57
122.94		28	655	0.50	58	26	665	0.47	58	23	690	0.43	58
106.00		32	630	0.55	59	30	635	0.52	59	26	675	0.48	59
98.80		34	620	0.58	59	32	635	0.55	59	28	665	0.51	59
86.36		39	600	0.63	60	37	610	0.60	60	32	635	0.55	60
80.96		42	585	0.66	60	40	600	0.63	60	35	635	0.58	60
71.44		48	485	0.63	58	45	565	0.67	60	39	620	0.63	61
63.33		54	325	0.55	51	51	450	0.63	57	44	595	0.68	61
53.83		63	255	0.52	49	59	285	0.54	50	52	470	0.66	59
55.93	27/2	61	620	0.78	77	57	630	0.75	76	50	635	0.67	76
51.30		66	600	0.82	77	62	620	0.80	77	55	635	0.72	76
43.68		78	585	0.94	77	73	595	0.90	77	64	620	0.82	77
37.66		90	565	1.0	78	85	575	0.99	78	74	600	0.91	78
35.10		97	550	1.1	78	91	565	1.0	78	80	585	0.95	78
30.68		111	540	1.2	78	104	550	1.2	78	91	565	1.0	78
28.76		118	515	1.2	78	111	540	1.2	78	97	565	1.1	78
25.38		134	415	1.2	77	126	470	1.2	78	110	550	1.2	79
22.50		151	275	0.93	71	142	380	1.1	76	124	505	1.3	79
19.13		178	210	0.87	69	167	240	0.90	70	146	390	1.2	77
19.89	24/5	171	370	1.2	86	161	380	1.1	86	141	390	1.0	86
18.24		186	365	1.2	86	175	370	1.2	86	154	390	1.1	86
15.53		219	345	1.3	86	206	355	1.3	86	180	370	1.2	86
13.39		254	325	1.5	86	239	345	1.5	86	209	365	1.3	86
12.48		272	325	1.6	86	256	335	1.6	86	224	355	2.0	86
10.91		312	310	1.7	86	293	320	1.7	86	257	345	1.6	87
10.23		332	310	1.9	87	313	320	1.9	87	274	335	1.7	87
9.02		377	275	1.9	86	355	300	2.0	87	310	320	1.7	87
8.00		425	175	1.5	82	400	255	1.9	86	350	310	2.0	87
6.80		500	140	1.3	81	471	160	1.5	82	412	255	1.9	86
6.33	537	210	2.1	87	506	240	2.1	88	442	285	2.3	88	
5.38	632	175	2.0	87	595	195	2.1	87	520	230	2.1	88	
4.86	700	160	2.0	87	658	170	2.0	87	576	210	2.3	88	
3.97	856	125	2.0	86	806	135	2.0	87	705	170	2.1	88	

All values reflect mechanical limits. Shaded area indicates additional thermal limitations where $P_{emax} = 1.5$ HP for continuous use.

2200 - 1400 rpm

02 955 197

S37													
i [ratio]	Worm ratio/ # starts	$n_e = 2200$ rpm				$n_e = 1700$ rpm				$n_e = 1400$ rpm			
		n_a [rpm]	T_{amax} [lb-in]	P_e [HP]	η [%]	n_a [rpm]	T_{amax} [lb-in]	P_e [HP]	η [%]	n_a [rpm]	T_{amax} [lb-in]	P_e [HP]	η [%]
157.43	38/1	14	770	0.31	56	11	805	0.25	54	8.9	815	0.21	53
144.40		15	760	0.32	56	12	795	0.27	55	9.7	815	0.23	54
122.94		18	735	0.36	57	14	770	0.30	56	11	805	0.27	55
106.00		21	715	0.40	58	16	760	0.34	57	13	780	0.30	56
98.80		22	710	0.43	58	17	750	0.36	57	14	770	0.31	56
86.36		25	690	0.47	59	20	725	0.39	58	16	760	0.34	57
80.96		27	680	0.50	60	21	725	0.42	59	17	750	0.36	58
71.44		31	665	0.54	60	24	710	0.44	60	20	745	0.39	59
63.33		35	645	0.59	61	27	700	0.50	60	22	725	0.43	60
53.83		41	610	0.64	62	32	675	0.55	61	26	710	0.48	61
55.93	27/2	39	680	0.56	75	30	715	0.47	74	25	715	0.39	73
51.30		43	675	0.60	76	33	710	0.50	75	27	715	0.42	74
43.68		50	655	0.68	76	39	690	0.56	76	32	715	0.48	75
37.66		58	635	0.76	77	45	675	0.63	76	37	700	0.55	76
35.10		63	630	0.80	77	48	665	0.67	77	40	690	0.58	76
30.68		72	620	0.90	78	55	645	0.74	77	46	675	0.63	76
28.76		76	600	0.94	78	59	645	0.78	77	49	665	0.67	77
25.38		87	595	1.0	79	67	630	0.86	78	55	655	0.74	77
22.50		98	585	1.1	79	76	620	0.94	79	62	645	0.82	78
19.13		115	560	1.3	80	89	600	1.1	79	73	630	0.93	79
19.89	24/5	111	425	0.87	85	85	445	0.71	85	70	460	0.62	84
18.24		121	415	0.94	85	93	435	0.75	85	77	460	0.67	84
15.53		142	400	1.0	86	109	425	0.86	85	90	445	0.75	85
13.39		164	390	1.2	86	127	415	0.98	86	105	435	0.84	85
12.48		176	380	1.2	86	136	405	1.0	86	112	425	0.89	86
10.91		202	370	1.3	87	156	400	1.1	86	128	425	1.0	86
10.23		215	365	1.5	87	166	400	1.2	87	137	415	0.78	86
9.02		244	355	1.6	87	188	380	1.3	87	155	405	1.2	87
8.00		275	345	1.7	87	213	380	1.5	87	175	400	1.3	87
6.80		324	325	1.9	88	250	365	1.6	88	206	380	1.5	87
6.33	348	310	2.0	88	269	310	1.5	88	221	310	1.2	87	
5.38	409	300	2.3	88	316	300	1.7	88	260	300	1.5	88	
4.86	453	285	2.3	89	350	290	1.7	88	288	290	1.5	88	
3.97	554	230	2.3	88	428	285	2.1	89	353	285	1.7	88	

All values reflect mechanical limits. Shaded area indicates additional thermal limitations where $P_{emax} = 1.5$ HP for continuous use.

1100 - 700 rpm

02 956 197

S37													
i [ratio]	Worm ratio/ # starts	$n_e = 1100 \text{ rpm}$				$n_e = 900 \text{ rpm}$				$n_e = 700 \text{ rpm}$			
		n_a [rpm]	T_{amax} [lb-in]	P_e [HP]	η [%]	n_a [rpm]	T_{amax} [lb-in]	P_e [HP]	η [%]	n_a [rpm]	T_{amax} [lb-in]	P_e [HP]	η [%]
157.43	38/1	7.0	815	0.17	52	5.7	815	0.15	50	4.4	815	0.12	49
144.40		7.6	815	0.19	52	6.2	815	0.16	51	4.8	815	0.12	50
122.94		8.9	815	0.21	54	7.3	815	0.19	52	5.7	815	0.15	51
106.00		10	815	0.24	55	8.5	815	0.20	53	6.6	815	0.16	52
98.80		11	815	0.25	55	9.1	815	0.21	54	7.1	815	0.17	52
86.36		13	795	0.28	56	10	815	0.24	55	8.1	815	0.20	53
80.96		14	790	0.30	57	11	815	0.25	55	8.6	815	0.21	54
71.44		15	770	0.32	57	13	805	0.28	56	9.8	815	0.23	55
63.33		17	760	0.36	58	14	790	0.31	57	11	815	0.25	56
53.83		20	745	0.40	60	17	770	0.35	58	13	805	0.30	57
55.93	27/2	20	770	0.34	72	16	805	0.28	71	13	815	0.23	70
51.30		21	770	0.36	73	18	795	0.31	72	14	815	0.25	71
43.68		25	745	0.40	74	21	770	0.35	73	16	815	0.30	71
37.66		29	725	0.46	75	24	760	0.39	74	19	790	0.32	72
35.10		31	725	0.48	75	26	745	0.42	74	20	780	0.34	73
30.68		36	710	0.54	76	29	725	0.46	75	23	770	0.38	74
28.76		38	700	0.56	76	31	725	0.48	75	24	760	0.40	74
25.38		43	690	0.62	77	35	715	0.54	76	28	745	0.44	75
22.50		49	680	0.68	77	40	700	0.58	76	31	725	0.48	75
19.13		58	665	0.78	78	47	690	0.67	77	37	715	0.55	76
19.89	24/5	55	485	0.51	83	45	515	0.44	83	35	530	0.36	82
18.24		60	480	0.55	84	49	495	0.47	83	38	530	0.39	82
15.53		71	470	0.63	84	58	485	0.54	84	45	515	0.44	83
13.39		82	460	0.71	85	67	480	0.60	84	52	495	0.50	83
12.48		88	450	0.74	85	72	470	0.63	84	56	485	0.52	84
10.91		101	445	0.83	86	82	460	0.71	85	64	480	0.58	84
10.23		108	435	0.86	86	88	450	0.74	85	68	480	0.62	84
9.02		122	425	0.95	86	100	445	0.82	86	78	470	0.68	85
8.00		138	415	1.0	87	113	435	0.90	86	88	460	0.75	85
6.80		162	405	1.2	87	132	425	1.0	87	103	450	0.86	86
6.33	24/5	174	400	1.3	87	142	400	1.0	87	111	400	0.82	86
5.38		204	380	1.4	88	167	380	1.2	87	130	380	0.91	87
4.86		226	370	1.5	88	185	370	1.2	88	144	370	0.98	87
3.97		277	355	1.8	88	227	355	1.4	88	176	355	1.1	88

500 - 10 rpm

02 956 197

S37													
i [ratio]	Worm ratio/ # starts	$n_e = 500$ rpm				$n_e = 250$ rpm				$n_e = 10$ rpm			
		n_a [rpm]	T_{amax} [lb-in]	P_e [HP]	η [%]	n_a [rpm]	T_{amax} [lb-in]	P_e [HP]	η [%]	n_a [rpm]	T_{amax} [lb-in]	P_e [HP]	η [%]
157.43	38/1	3.2	815	0.08	47	1.6	815	0.04	46	0.06	815	0.00	26
144.40		3.5	815	0.09	48	1.7	815	0.05	46	0.07	815	0.00	27
122.94		4.1	815	0.11	49	2.0	815	0.06	46	0.08	815	0.00	29
106.00		4.7	815	0.12	50	2.4	815	0.07	47	0.09	815	0.00	30
98.80		5.1	815	0.13	50	2.5	815	0.07	47	0.10	815	0.00	31
86.36		5.8	815	0.15	51	2.9	815	0.08	47	0.12	815	0.00	32
80.96		6.2	815	0.16	51	3.1	815	0.08	47	0.12	815	0.00	33
71.44		7.0	815	0.17	52	3.5	815	0.09	48	0.14	815	0.00	35
63.33		7.9	815	0.19	53	3.9	815	0.11	49	0.16	815	0.00	37
53.83		9.3	815	0.21	55	4.6	815	0.12	50	0.19	815	0.00	39
55.93	27/2	8.9	815	0.17	69	4.5	815	0.08	67	0.18	815	0.00	48
51.30		9.7	815	0.19	69	4.9	815	0.09	67	0.19	815	0.00	49
43.68		11	815	0.21	70	5.7	815	0.11	67	0.23	815	0.00	51
37.66		13	815	0.24	71	6.6	815	0.13	67	0.27	815	0.00	53
35.10		14	815	0.25	71	7.1	815	0.13	68	0.28	815	0.00	54
30.68		16	815	0.30	72	8.1	815	0.15	68	0.33	815	0.00	56
28.76		17	805	0.31	72	8.7	815	0.16	69	0.35	815	0.00	57
25.38		20	790	0.34	73	9.9	815	0.19	69	0.39	815	0.00	59
22.50		22	770	0.38	74	11	815	0.20	70	0.44	815	0.00	61
19.13		26	750	0.42	75	13	815	0.24	71	0.52	815	0.00	62
19.89	24/5	25	600	0.30	81	13	635	0.16	79	0.50	635	0.00	65
18.24		27	585	0.31	81	14	635	0.17	79	0.55	635	0.00	66
15.53		32	560	0.35	82	16	635	0.20	79	0.64	635	0.00	68
13.39		37	540	0.39	82	19	635	0.24	80	0.75	635	0.00	71
12.48		40	520	0.40	82	20	635	0.25	80	0.80	635	0.00	72
10.91		46	515	0.46	83	23	630	0.28	81	0.92	630	0.00	73
10.23		49	505	0.47	83	24	620	0.30	81	0.98	620	0.00	73
9.02		55	495	0.52	84	28	585	0.32	81	1.1	585	0.00	74
8.00		63	485	0.58	84	31	560	0.34	82	1.2	560	0.00	74
6.80		74	480	0.66	85	37	540	0.39	82	1.5	540	0.00	75
6.33	79	400	0.59	85	39	400	0.31	83	1.6	400	0.00	80	
5.38	93	380	0.66	86	46	380	0.34	83	1.9	380	0.00	80	
4.86	103	370	0.71	86	51	370	0.36	84	2.1	370	0.00	80	
3.97	126	355	0.82	87	63	355	0.42	84	2.5	355	0.00	80	

11

11.10.2 S47

3400 - 2800 rpm

02 957 197

S47													
i [ratio]	Worm ratio/ # starts	$n_e = 3400 \text{ rpm}$				$n_e = 3200 \text{ rpm}$				$n_e = 2800 \text{ rpm}$			
		n_a [rpm]	T_{amax} [lb-in]	P_e [HP]	η [%]	n_a [rpm]	T_{amax} [lb-in]	P_e [HP]	η [%]	n_a [rpm]	T_{amax} [lb-in]	P_e [HP]	η [%]
201.00	42/1	17	1330	0.59	60	16	1330	0.56	60	14	1330	0.50	59
184.80		18	1330	0.64	60	17	1330	0.60	60	15	1330	0.54	59
158.12		22	1330	0.74	61	20	1330	0.70	61	18	1330	0.62	60
137.05		25	1330	0.84	62	23	1330	0.79	62	20	1330	0.70	61
128.10		27	1330	0.90	63	25	1330	0.84	62	22	1330	0.75	62
110.73		31	1220	0.94	63	29	1310	0.95	63	25	1330	0.84	63
94.08		36	1000	0.93	62	34	1090	0.94	63	30	1290	0.97	63
84.00		40	840	0.89	61	38	945	0.93	62	33	1150	0.95	63
71.75		47	515	0.74	53	45	725	0.86	60	39	945	0.94	63
67.20		51	470	0.72	52	48	600	0.80	57	42	875	0.93	62
56.61	29/2	60	355	0.68	49	57	405	0.71	51	49	665	0.87	60
69.39		49	1240	1.2	79	46	1240	1.2	78	40	1240	1.0	78
63.80		53	1240	1.3	79	50	1240	1.2	79	44	1240	1.1	78
54.59		62	1240	1.5	80	59	1240	1.5	79	51	1240	1.3	79
47.32		72	1230	1.7	80	68	1240	1.6	80	59	1240	1.5	80
44.22		77	1140	1.7	80	72	1230	1.7	80	63	1240	1.6	80
38.23		89	990	1.7	80	84	1060	1.7	80	73	1230	1.7	80
32.48		105	805	1.7	79	99	885	1.7	80	86	1035	1.7	80
29.00		117	675	1.6	78	110	760	1.7	79	97	920	1.7	80
24.77		137	415	1.3	72	129	585	1.6	77	113	770	1.7	80
23.20	27/5	147	370	1.2	71	138	480	1.3	75	121	700	1.7	79
19.54		174	285	1.1	69	164	325	1.2	71	143	520	1.5	77
20.33		167	885	2.7	88	157	885	2.5	88	138	885	2.1	88
17.62		193	860	3.0	88	182	885	3.0	88	159	885	2.5	88
16.47		206	795	3.0	88	194	860	3.0	88	170	885	2.7	88
14.24		239	690	3.0	88	225	735	3.0	88	197	860	3.1	88
12.10		281	560	2.8	88	264	610	3.0	88	231	725	3.0	88
10.80		315	470	2.7	87	296	530	2.8	88	259	635	3.0	88
9.23		368	285	2.0	83	347	400	2.5	86	303	530	3.0	88
8.64		394	255	2.0	82	370	325	2.3	85	324	485	2.8	88
7.28	467	195	1.7	81	440	220	1.9	82	385	365	2.5	86	
6.83	498	300	2.7	87	469	325	2.7	88	410	400	3.0	88	
6.40	531	275	2.7	87	500	300	2.7	87	438	370	3.0	88	
5.39	631	210	2.4	86	594	240	2.5	87	519	300	2.8	88	
4.76	714	175	2.4	85	672	205	2.5	86	588	255	2.7	87	
4.00	850	140	2.3	85	800	160	2.4	85	700	205	2.5	87	

All values reflect mechanical limits. Shaded area indicates additional thermal limitations where $P_{emax} = 2.0 \text{ HP}$ for continuous use.

2200 - 1400 rpm

02 957 197

S47													
i [ratio]	Worm ratio/ # starts	$n_e = 2200 \text{ rpm}$				$n_e = 1700 \text{ rpm}$				$n_e = 1400 \text{ rpm}$			
		n_a [rpm]	T_{amax} [lb-in]	P_e [HP]	η [%]	n_a [rpm]	T_{amax} [lb-in]	P_e [HP]	η [%]	n_a [rpm]	T_{amax} [lb-in]	P_e [HP]	η [%]
201.00	42/1	11	1480	0.44	58	8.5	1505	0.36	56	7.0	1505	0.31	55
184.80		12	1480	0.48	58	9.2	1485	0.39	57	7.6	1505	0.32	56
158.12		14	1480	0.55	60	11	1485	0.44	58	8.9	1505	0.38	57
137.05		16	1460	0.62	60	12	1480	0.50	59	10	1485	0.42	58
128.10		17	1460	0.66	61	13	1480	0.52	59	11	1485	0.44	58
110.73		20	1460	0.74	62	15	1480	0.59	61	13	1485	0.51	59
94.08		23	1460	0.86	63	18	1480	0.68	62	15	1485	0.58	60
84.00		26	1435	0.94	64	20	1480	0.76	62	17	1480	0.64	61
71.75		31	1285	0.98	64	24	1480	0.87	63	20	1480	0.74	62
67.20		33	1210	0.98	64	25	1450	0.91	64	21	1480	0.78	63
56.61	29/2	39	1020	0.98	64	30	1345	0.99	65	25	1460	0.90	64
69.39		32	1370	0.90	77	24	1370	0.70	76	20	1370	0.59	75
63.80		34	1370	0.97	77	27	1370	0.76	76	22	1370	0.63	75
54.59		40	1370	1.1	78	31	1370	0.89	77	26	1370	0.74	76
47.32		46	1370	1.3	79	36	1370	1.0	78	30	1370	0.84	77
44.22		50	1370	1.3	79	38	1370	1.1	78	32	1370	0.90	77
38.23		58	1370	1.6	80	44	1370	1.2	79	37	1370	1.0	78
32.48		68	1290	1.7	80	52	1370	1.5	80	43	1370	1.2	79
29.00		76	1210	1.7	81	59	1365	1.6	80	48	1370	1.3	79
24.77		89	1035	1.7	81	69	1285	1.7	81	57	1370	1.5	80
23.20	95	980	1.9	81	73	1255	1.7	81	60	1345	1.6	80	
19.54	27/5	113	815	1.7	81	87	1090	1.9	81	72	1275	1.7	81
20.33		108	965	1.9	87	84	975	1.5	87	69	975	1.2	86
17.62		125	955	2.1	88	96	965	1.7	87	79	975	1.5	86
16.47		134	955	2.3	88	103	965	1.9	87	85	975	1.5	87
14.24		154	955	2.7	88	119	965	2.1	88	98	975	1.7	87
12.10		182	930	3.1	89	140	965	2.4	88	116	965	2.0	88
10.80		204	840	3.1	89	157	955	2.7	88	130	965	2.3	88
9.23		238	725	3.1	89	184	930	3.1	89	152	965	2.7	88
8.64		255	680	3.1	89	197	885	3.1	89	162	965	2.8	88
7.28		302	565	3.1	89	234	760	3.2	89	192	910	3.1	89
6.83	322	550	3.2	89	249	690	3.1	89	205	690	2.5	89	
6.40	344	515	3.2	89	266	675	3.2	89	219	675	2.7	89	
5.39	408	425	3.1	89	315	575	3.2	89	260	655	3.1	89	
4.76	462	370	3.1	89	357	515	3.2	89	294	635	3.4	90	
4.00	550	300	3.0	88	425	425	3.2	89	350	540	3.4	90	

All values reflect mechanical limits. Shaded area indicates additional thermal limitations where $P_{emax} = 2.0 \text{ HP}$ for continuous use.

1100 - 700 rpm

02 958 197

S47													
i [ratio]	Worm ratio/ # starts	$n_e = 1100 \text{ rpm}$				$n_e = 900 \text{ rpm}$				$n_e = 700 \text{ rpm}$			
		n_a [rpm]	T_{amax} [lb-in]	P_e [HP]	η [%]	n_a [rpm]	T_{amax} [lb-in]	P_e [HP]	η [%]	n_a [rpm]	T_{amax} [lb-in]	P_e [HP]	η [%]
201.00	42/1	5.5	1560	0.25	53	4.5	1595	0.21	52	3.5	1635	0.17	51
184.80		6.0	1540	0.27	54	4.9	1575	0.23	53	3.8	1620	0.19	51
158.12		7.0	1520	0.31	55	5.7	1560	0.27	54	4.4	1595	0.21	52
137.05		8.0	1515	0.35	56	6.6	1520	0.30	55	5.1	1575	0.24	53
128.10		8.6	1515	0.36	57	7.0	1520	0.31	55	5.5	1560	0.25	54
110.73		9.9	1495	0.40	58	8.1	1515	0.35	56	6.3	1540	0.28	55
94.08		12	1495	0.47	59	9.6	1515	0.40	57	7.4	1520	0.32	56
84.00		13	1495	0.52	60	11	1495	0.43	58	8.3	1515	0.35	57
71.75		15	1495	0.60	61	13	1495	0.50	60	9.8	1515	0.40	58
67.20		16	1495	0.63	61	13	1495	0.54	60	10	1515	0.43	58
56.61	19	1495	0.74	63	16	1495	0.62	61	12	1515	0.50	60	
69.39	29/2	16	1530	0.52	74	13	1560	0.44	73	10	1595	0.36	71
63.80		17	1530	0.56	74	14	1550	0.47	73	11	1595	0.39	72
54.59		20	1515	0.64	75	16	1530	0.54	74	13	1560	0.44	73
47.32		23	1515	0.74	76	19	1530	0.62	75	15	1550	0.50	73
44.22		25	1515	0.78	76	20	1515	0.66	75	16	1550	0.52	74
38.23		29	1495	0.89	77	24	1515	0.75	76	18	1530	0.59	75
32.48		34	1495	1.0	78	28	1515	0.87	77	22	1515	0.68	75
29.00		38	1505	1.2	78	31	1515	0.97	77	24	1515	0.76	76
24.77		44	1495	1.3	79	36	1505	1.1	78	28	1515	0.89	77
23.20		47	1450	1.3	79	39	1505	1.2	79	30	1515	0.94	77
19.54	27/5	56	1365	1.5	80	46	1460	1.3	79	36	1505	1.1	78
20.33		54	990	1.0	85	44	1010	0.84	84	34	1025	0.67	83
17.62		62	990	1.2	86	51	1000	0.95	85	40	1020	0.76	84
16.47		67	990	1.2	86	55	1000	1.0	85	43	1010	0.80	84
14.24		77	980	1.3	86	63	990	1.2	86	49	1000	0.93	85
12.10		91	980	1.6	87	74	980	1.3	86	58	1000	1.1	85
10.80		102	980	1.9	87	83	980	1.5	87	65	990	1.2	86
9.23		119	975	2.1	88	98	980	1.7	87	76	990	1.3	86
8.64		127	965	2.3	88	104	980	1.9	87	81	990	1.5	87
7.28		151	965	2.7	88	124	980	2.1	88	96	980	1.7	87
6.83	161	840	2.4	89	132	840	2.0	88	102	840	1.6	88	
6.40	172	825	2.5	89	141	825	2.1	88	109	825	1.6	88	
5.39	204	790	2.8	89	167	790	2.4	89	130	790	1.9	88	
4.76	231	770	3.2	89	189	770	2.5	89	147	770	2.0	89	
4.00	275	690	3.4	90	225	745	3.0	89	175	745	2.3	89	

All values reflect mechanical limits. Shaded area indicates additional thermal limitations where $P_{emax} = 2.0 \text{ HP}$ for continuous use.

500 - 10 rpm

02 958 197

S47													
i [ratio]	Worm ratio/ # starts	n_e = 500 rpm				n_e = 250 rpm				n_e = 10 rpm			
		n _a [rpm]	T _{amax} [lb-in]	P _e [HP]	η [%]	n _a [rpm]	T _{amax} [lb-in]	P _e [HP]	η [%]	n _a [rpm]	T _{amax} [lb-in]	P _e [HP]	η [%]
201.00	42/1	2.5	1635	0.13	49	1.2	1635	0.07	48	0.05	1635	0.00	32
184.80		2.7	1635	0.15	49	1.4	1635	0.07	48	0.05	1635	0.00	32
158.12		3.2	1635	0.16	50	1.6	1635	0.08	48	0.06	1635	0.00	35
137.05		3.6	1635	0.19	51	1.8	1635	0.09	48	0.07	1635	0.00	37
128.10		3.9	1620	0.20	51	2.0	1635	0.11	48	0.08	1635	0.00	38
110.73		4.5	1600	0.21	52	2.3	1635	0.12	49	0.09	1635	0.00	40
94.08		5.3	1575	0.25	54	2.7	1635	0.13	49	0.11	1635	0.00	42
84.00		6.0	1560	0.27	54	3.0	1635	0.16	50	0.12	1635	0.00	43
71.75		7.0	1540	0.31	56	3.5	1635	0.17	51	0.14	1635	0.00	44
67.20		7.4	1520	0.32	56	3.7	1635	0.19	51	0.15	1635	0.00	44
56.61	29/2	8.8	1520	0.38	57	4.4	1600	0.21	53	0.18	1600	0.00	45
69.39		7.2	1635	0.27	70	3.6	1635	0.13	68	0.14	1635	0.00	56
63.80		7.8	1635	0.30	70	3.9	1635	0.15	68	0.16	1635	0.00	57
54.59		9.2	1635	0.34	71	4.6	1635	0.17	68	0.18	1635	0.00	60
47.32		11	1600	0.38	72	5.3	1635	0.20	68	0.21	1635	0.00	61
44.22		11	1595	0.40	72	5.7	1635	0.21	69	0.23	1635	0.00	62
38.23		13	1575	0.44	73	6.5	1635	0.24	69	0.26	1635	0.00	63
32.48		15	1540	0.51	74	7.7	1635	0.28	70	0.31	1635	0.00	64
29.00		17	1540	0.56	74	8.6	1635	0.32	71	0.34	1635	0.00	65
24.77		20	1520	0.64	75	10	1620	0.36	71	0.40	1620	0.00	66
23.20	27/5	22	1520	0.68	76	11	1600	0.38	72	0.43	1600	0.00	66
19.54		26	1520	0.80	77	13	1575	0.44	73	0.51	1575	0.00	67
20.33		25	1095	0.52	82	12	1390	0.34	80	0.49	1390	0.00	75
17.62		28	1060	0.58	83	14	1320	0.38	80	0.57	1320	0.00	76
16.47		30	1045	0.60	83	15	1285	0.39	81	0.61	1285	0.00	76
14.24		35	1025	0.68	84	18	1220	0.42	81	0.70	1220	0.00	77
12.10		41	1020	0.79	84	21	1160	0.47	82	0.83	1160	0.00	77
10.80		46	1010	0.87	85	23	1125	0.50	82	0.93	1125	0.00	77
9.23		54	1000	1.0	85	27	1070	0.55	83	1.1	1070	0.00	78
8.64		58	1000	1.1	86	29	1060	0.59	83	1.2	1060	0.00	78
7.28	69	990	1.2	86	34	1035	0.67	84	1.4	1035	0.00	78	
6.83	73	840	1.1	87	37	840	0.58	84	1.5	840	0.00	81	
6.40	78	825	1.2	87	39	825	0.60	85	1.6	825	0.00	81	
5.39	93	790	1.3	87	46	790	0.68	85	1.9	790	0.00	81	
4.76	105	770	1.5	88	53	770	0.75	86	2.1	770	0.00	81	
4.00	125	745	1.7	88	63	745	0.86	86	2.5	745	0.00	81	

11

11.10.3 S57

3400 - 2800 rpm

02 959 197

S57													
i [ratio]	Worm ratio/ # starts	$n_e = 3400 \text{ rpm}$				$n_e = 3200 \text{ rpm}$				$n_e = 2800 \text{ rpm}$			
		n_a [rpm]	T_{amax} [lb-in]	P_e [HP]	η [%]	n_a [rpm]	T_{amax} [lb-in]	P_e [HP]	η [%]	n_a [rpm]	T_{amax} [lb-in]	P_e [HP]	η [%]
201.00	42/1	17	2390	1.0	64	16	2390	0.95	63	14	2390	0.84	62
184.80		18	2390	1.1	64	17	2390	1.0	64	15	2390	0.91	63
158.12		22	2390	1.2	65	20	2390	1.2	65	18	2390	1.0	64
137.05		25	2255	1.3	66	23	2390	1.3	66	20	2390	1.2	65
128.10		27	2170	1.3	66	25	2255	1.3	66	22	2390	1.3	65
110.73		31	1905	1.3	67	29	2035	1.3	67	25	2255	1.3	66
94.08		36	1630	1.3	67	34	1735	1.3	67	30	1990	1.5	67
84.00		40	1460	1.3	67	38	1550	1.3	67	33	1770	1.3	67
71.75		47	1230	1.3	67	45	1320	1.3	67	39	1540	1.5	67
67.20		51	1135	1.3	66	48	1230	1.3	67	42	1450	1.5	67
56.61	29/2	60	910	1.3	65	57	1010	1.3	66	49	1220	1.5	67
69.39		49	1945	1.9	81	46	1945	1.7	80	40	1945	1.6	80
63.80		53	1945	2.0	81	50	1945	1.9	81	44	1945	1.7	80
54.59		62	1945	2.4	81	59	1945	2.3	81	51	1945	2.0	81
47.32		72	1860	2.5	82	68	1945	2.5	82	59	1945	2.3	81
44.22		77	1745	2.5	82	72	1815	2.5	82	63	1945	2.4	81
38.23		89	1540	2.7	82	84	1630	2.7	82	73	1815	2.5	82
32.48		105	1310	2.7	82	99	1390	2.7	82	86	1595	2.7	82
29.00		117	1160	2.7	82	110	1250	2.7	82	97	1435	2.7	82
24.77		137	980	2.5	82	129	1060	2.7	82	113	1230	2.7	82
23.20	27/5	147	905	2.5	82	138	980	2.7	82	121	1160	2.7	82
19.54		174	715	2.4	81	164	795	2.5	82	143	965	2.7	82
20.33		167	1415	4.3	89	157	1415	4.0	89	138	1415	3.5	88
17.62		193	1240	4.3	89	182	1320	4.3	89	159	1415	4.0	89
16.47		206	1170	4.3	89	194	1240	4.3	89	170	1400	4.3	89
14.24		239	1025	4.3	89	225	1090	4.3	89	197	1230	4.3	89
12.10		281	875	4.4	89	264	930	4.4	89	231	1070	4.4	89
10.80		315	780	4.4	89	296	830	4.4	89	259	955	4.4	89
9.23		368	645	4.3	89	347	700	4.3	89	303	825	4.4	89
8.64		394	600	4.3	89	370	655	4.3	89	324	770	4.4	89
7.28	467	480	4.0	88	440	530	4.2	89	385	635	4.3	89	
6.83	498	480	4.3	89	469	515	4.3	89	410	610	4.4	90	
6.40	531	445	4.2	89	500	480	4.3	89	438	565	4.4	89	
5.39	631	365	4.2	89	594	390	4.2	89	519	470	4.3	89	
4.76	714	310	4.0	88	672	335	4.0	89	588	405	4.3	89	
4.00	850	250	3.8	88	800	275	3.9	88	700	335	4.2	89	

All values reflect mechanical limits. Shaded area indicates additional thermal limitations where $P_{emax} = 4.0 \text{ HP}$ for continuous use.

2200 - 1400 rpm

02 959 197

S57													
i [ratio]	Worm ratio/ # starts	$n_e = 2200 \text{ rpm}$				$n_e = 1700 \text{ rpm}$				$n_e = 1400 \text{ rpm}$			
		n_a [rpm]	T_{amax} [lb-in]	P_e [HP]	η [%]	n_a [rpm]	T_{amax} [lb-in]	P_e [HP]	η [%]	n_a [rpm]	T_{amax} [lb-in]	P_e [HP]	η [%]
201.00	42/1	11	2610	0.74	61	8.5	2610	0.59	59	7.0	2610	0.50	58
184.80		12	2610	0.80	62	9.2	2610	0.64	60	7.6	2610	0.54	58
158.12		14	2610	0.93	63	11	2610	0.74	61	8.9	2610	0.62	60
137.05		16	2610	1.0	64	12	2610	0.83	62	10	2610	0.70	61
128.10		17	2610	1.1	64	13	2610	0.89	62	11	2610	0.74	61
110.73		20	2565	1.2	65	15	2610	1.0	63	13	2610	0.84	62
94.08		23	2435	1.3	66	18	2655	1.2	65	15	2610	0.98	63
84.00		26	2215	1.3	67	20	2520	1.2	65	17	2610	1.1	64
71.75		31	1945	1.5	67	24	2435	1.3	66	20	2565	1.2	65
67.20		33	1860	1.5	67	25	2300	1.3	67	21	2520	1.3	65
56.61	29/2	39	1585	1.5	68	30	1990	1.5	67	25	2345	1.3	67
69.39		32	2170	1.3	79	24	2170	1.1	77	20	2170	0.91	76
63.80		34	2170	1.5	79	27	2170	1.2	78	22	2170	0.98	77
54.59		40	2170	1.7	80	31	2170	1.3	79	26	2170	1.1	78
47.32		46	2170	2.0	81	36	2170	1.6	79	30	2170	1.3	79
44.22		50	2170	2.1	81	38	2170	1.6	80	32	2170	1.3	79
38.23		58	2170	2.4	81	44	2170	1.9	80	37	2170	1.6	80
32.48		68	1990	2.5	82	52	2170	2.3	81	43	2170	1.9	80
29.00		76	1770	2.5	82	59	2170	2.4	81	48	2170	2.0	81
24.77		89	1565	2.7	82	69	1945	2.5	82	57	2170	2.4	81
23.20	27/5	95	1480	2.7	83	73	1860	2.7	82	60	2170	2.5	82
19.54		113	1265	2.7	83	87	1620	2.7	83	72	1905	2.7	82
20.33		108	1485	3.0	88	84	1485	2.3	87	69	1485	1.9	87
17.62		125	1485	3.4	88	96	1485	2.5	88	79	1485	2.1	87
16.47		134	1495	3.6	88	103	1485	2.8	88	85	1485	2.3	87
14.24		154	1495	4.2	89	119	1495	3.2	88	98	1495	2.7	88
12.10		182	1330	4.3	89	140	1495	3.8	89	116	1495	3.1	88
10.80		204	1205	4.3	89	157	1495	4.2	89	130	1495	3.5	88
9.23		238	1055	4.4	89	184	1320	4.3	89	152	1495	4.0	89
8.64		255	990	4.4	89	197	1250	4.4	89	162	1470	4.3	89
7.28	302	850	4.6	90	234	1080	4.4	90	192	1290	4.4	89	
6.83	322	805	4.6	90	249	885	3.9	90	205	885	3.2	89	
6.40	344	750	4.6	90	266	865	4.0	90	219	865	3.4	89	
5.39	408	635	4.6	90	315	840	4.7	90	260	840	3.9	90	
4.76	462	560	4.6	90	357	745	4.7	90	294	825	4.3	90	
4.00	550	470	4.6	90	425	630	4.7	90	350	780	4.8	90	

All values reflect mechanical limits. Shaded area indicates additional thermal limitations where $P_{emax} = 4.0 \text{ HP}$ for continuous use.

1100 - 700 rpm

02 960 197

S57													
i [ratio]	Worm ratio/ # starts	$n_e = 1100 \text{ rpm}$				$n_e = 900 \text{ rpm}$				$n_e = 700 \text{ rpm}$			
		n_a [rpm]	T_{amax} [lb-in]	P_e [HP]	η [%]	n_a [rpm]	T_{amax} [lb-in]	P_e [HP]	η [%]	n_a [rpm]	T_{amax} [lb-in]	P_e [HP]	η [%]
201.00	42/1	5.5	2610	0.40	56	4.5	2660	0.35	55	3.5	2740	0.28	53
184.80		6.0	2610	0.43	57	4.9	2660	0.38	55	3.8	2700	0.31	54
158.12		7.0	2610	0.50	58	5.7	2610	0.42	56	4.4	2660	0.34	55
137.05		8.0	2610	0.56	59	6.6	2610	0.47	57	5.1	2660	0.39	56
128.10		8.6	2610	0.60	59	7.0	2610	0.50	58	5.5	2610	0.40	56
110.73		9.9	2610	0.68	61	8.1	2610	0.58	59	6.3	2610	0.46	57
94.08		12	2610	0.79	62	9.6	2610	0.66	60	7.4	2610	0.52	58
84.00		13	2610	0.87	63	11	2610	0.72	61	8.3	2610	0.58	59
71.75		15	2610	0.99	64	13	2610	0.83	62	9.8	2610	0.67	61
67.20		16	2660	1.1	64	13	2610	0.89	63	10	2610	0.71	61
56.61	19	2570	1.2	65	16	2660	1.0	64	12	2610	0.82	62	
69.39	29/2	16	2390	0.80	75	13	2390	0.66	74	10	2390	0.52	73
63.80		17	2390	0.86	76	14	2390	0.71	75	11	2390	0.56	73
54.59		20	2390	0.99	77	16	2390	0.83	75	13	2390	0.66	74
47.32		23	2390	1.1	77	19	2390	0.94	76	15	2390	0.75	75
44.22		25	2390	1.2	78	20	2390	1.0	77	16	2390	0.79	75
38.23		29	2390	1.3	79	24	2390	1.2	77	18	2390	0.91	76
32.48		34	2390	1.6	79	28	2390	1.3	78	22	2390	1.1	77
29.00		38	2390	1.7	80	31	2390	1.5	79	24	2390	1.2	78
24.77		44	2390	2.1	81	36	2390	1.7	80	28	2390	1.3	78
23.20		47	2390	2.3	81	39	2390	1.9	80	30	2390	1.5	79
19.54	56	2210	2.4	81	46	2390	2.1	81	36	2390	1.7	80	
20.33	27/5	54	1490	1.5	86	44	1500	1.2	85	34	1520	0.99	84
17.62		62	1500	1.7	86	51	1500	1.5	86	40	1500	1.1	85
16.47		67	1490	1.9	87	55	1490	1.5	86	43	1500	1.2	85
14.24		77	1490	2.1	87	63	1490	1.7	86	49	1500	1.3	86
12.10		91	1500	2.4	88	74	1500	2.0	87	58	1500	1.6	86
10.80		102	1500	2.8	88	83	1500	2.3	87	65	1500	1.7	87
9.23		119	1500	3.2	88	98	1490	2.7	88	76	1490	2.0	87
8.64		127	1500	3.5	88	104	1500	2.8	88	81	1490	2.1	87
7.28		151	1500	4.0	89	124	1500	3.4	88	96	1500	2.5	88
6.83		161	1060	3.1	89	132	1060	2.5	89	102	1060	2.0	88
6.4	172	1040	3.2	89	141	1040	2.5	89	109	1040	2.0	88	
5.39	204	980	3.6	90	167	980	3.0	89	130	980	2.3	89	
4.76	231	955	3.9	90	189	955	3.2	90	147	955	2.5	89	
4.00	275	910	4.4	90	225	910	3.6	90	175	910	2.8	89	

All values reflect mechanical limits. Shaded area indicates additional thermal limitations where $P_{emax} = 4.0 \text{ HP}$ for continuous use.

500 - 10 rpm

02 960 197

S57													
i [ratio]	Worm ratio/ # starts	n_e = 500 rpm				n_e = 250 rpm				n_e = 10 rpm			
		n _a [rpm]	T _{amax} [lb-in]	P _e [HP]	η [%]	n _a [rpm]	T _{amax} [lb-in]	P _e [HP]	η [%]	n _a [rpm]	T _{amax} [lb-in]	P _e [HP]	η [%]
201.00	42/1	2.5	2920	0.23	51	1.2	2920	0.12	49	0.05	2920	0.00	42
184.80		2.7	2920	0.24	51	1.4	2920	0.13	49	0.05	2920	0.00	43
158.12		3.2	2790	0.27	52	1.6	2920	0.15	49	0.06	2920	0.00	44
137.05		3.6	2740	0.30	53	1.8	2920	0.17	50	0.07	2920	0.00	45
128.10		3.9	2700	0.31	54	2.0	2920	0.19	50	0.08	2920	0.00	46
110.73		4.5	2660	0.35	55	2.3	2920	0.20	51	0.09	2920	0.00	46
94.08		5.3	2660	0.40	56	2.7	2920	0.24	51	0.11	2920	0.00	47
84.00		6.0	2610	0.43	57	3.0	2880	0.25	52	0.12	2880	0.00	47
71.75		7.0	2610	0.50	58	3.5	2740	0.28	53	0.14	2740	0.00	48
67.20		7.4	2610	0.52	58	3.7	2740	0.31	54	0.15	2740	0.00	48
56.61		8.8	2610	0.62	60	4.4	2660	0.34	55	0.18	2660	0.00	48
69.39		29/2	7.2	2660	0.43	71	3.6	2660	0.23	68	0.14	2660	0.00
63.80	7.8		2660	0.46	71	3.9	2660	0.24	68	0.16	2660	0.00	64
54.59	9.2		2660	0.54	72	4.6	2660	0.28	69	0.18	2660	0.00	65
47.32	11		2660	0.60	73	5.3	2660	0.32	70	0.21	2660	0.00	66
44.22	11		2660	0.64	74	5.7	2660	0.34	70	0.23	2660	0.00	66
38.23	13		2610	0.72	74	6.5	2660	0.39	71	0.26	2660	0.00	67
32.48	15		2610	0.84	75	7.7	2660	0.46	71	0.31	2660	0.00	67
29.00	17		2610	0.94	76	8.6	2660	0.51	72	0.34	2660	0.00	67
24.77	20		2610	1.1	77	10	2660	0.58	73	0.40	2660	0.00	68
23.20	22		2610	1.2	77	11	2660	0.62	73	0.43	2660	0.00	68
19.54	26		2610	1.3	78	13	2610	0.71	74	0.51	2610	0.00	68
20.33	25		1600	0.75	83	12	1900	0.47	80	0.49	1900	0.00	77
17.62	28	1550	0.83	83	14	1860	0.52	81	0.57	1860	0.00	77	
16.47	30	1540	0.89	84	15	1810	0.54	81	0.61	1810	0.00	78	
14.24	35	1520	1.0	84	18	1750	0.60	81	0.70	1750	0.00	78	
12.10	41	1500	1.2	85	21	1660	0.66	82	0.83	1660	0.00	78	
10.80	46	1500	1.3	85	23	1630	0.72	83	0.93	1630	0.00	78	
9.23	27/5	54	1500	1.5	86	27	1570	0.80	83	1.1	1570	0.00	79
8.64		58	1500	1.6	86	29	1550	0.86	83	1.2	1550	0.00	79
7.28		69	1500	1.9	87	34	1520	0.98	84	1.4	1520	0.00	79
6.83		73	1060	1.5	87	37	1060	0.72	85	1.5	1060	0.00	81
6.40		78	1040	1.5	87	39	1040	0.75	85	1.6	1040	0.00	81
5.39		93	980	1.6	88	46	980	0.84	86	1.9	980	0.00	81
4.76		105	955	1.9	88	53	955	0.93	86	2.1	955	0.00	81
4.00		125	910	2.0	89	63	910	1.0	87	2.5	910	0.00	81

11.10.4 S67

3400 - 2800 rpm

02 961 097

S67														
i [ratio]	Worm ratio/ # starts	$n_e = 3400 \text{ rpm}$				$n_e = 3200 \text{ rpm}$				$n_e = 2800 \text{ rpm}$				
		n_a [rpm]	T_{amax} [lb-in]	P_e [HP]	η [%]	n_a [rpm]	T_{amax} [lb-in]	P_e [HP]	η [%]	n_a [rpm]	T_{amax} [lb-in]	P_e [HP]	η [%]	
217.41	42/1	16	4120	1.6	66	15	4120	1.5	66	13	4120	1.3	65	
190.11		18	4120	1.7	67	17	4120	1.6	67	15	4120	1.5	66	
180.60		19	4120	1.9	67	18	4120	1.7	67	16	4120	1.5	66	
158.45		21	4120	2.0	68	20	4120	2.0	68	18	4120	1.7	67	
134.40		25	4120	2.4	69	24	4120	2.3	68	21	4120	2.0	68	
121.33		28	4030	2.5	69	26	4120	2.5	69	23	4120	2.1	68	
106.75		32	3580	2.7	69	30	3810	2.7	69	26	4120	2.5	69	
100.80		34	3360	2.5	69	32	3630	2.7	69	28	4120	2.7	69	
85.83		40	2830	2.5	69	37	3050	2.5	69	33	3540	2.7	70	
78.00		44	2520	2.5	69	41	2740	2.5	69	36	3230	2.7	70	
67.57		50	2080	2.4	67	47	2300	2.5	68	41	2790	2.7	69	
58.80		58	1630	2.3	65	54	1900	2.4	67	48	2390	2.5	69	
75.06		29/2	45	3850	3.4	82	43	3850	3.2	82	37	3850	2.8	81
65.63			52	3850	3.9	82	49	3850	3.6	82	43	3850	3.2	82
62.35			55	3850	4.0	83	51	3850	3.8	82	45	3850	3.4	82
54.70	62		3850	4.6	83	59	3850	4.3	83	51	3850	3.8	83	
46.40	73		3500	4.8	83	69	3670	4.8	83	60	3850	4.4	83	
41.89	81		3140	4.8	83	76	3360	4.8	83	67	3810	4.8	83	
36.85	92		2740	4.8	83	87	2960	4.8	84	76	3360	4.8	84	
34.80	98		2610	4.8	83	92	2790	4.8	84	80	3230	5.0	84	
29.63	115		2210	4.8	83	108	2390	5.0	83	94	2740	5.0	84	
26.93	126		1950	4.7	83	119	2120	4.8	83	104	2480	4.8	84	
23.33	146		1610	4.6	82	137	1770	4.7	83	120	2170	5.0	84	
20.30	167		1250	4.2	81	158	1450	4.4	82	138	1810	4.8	83	
24.44	139		2790	6.8	90	131	2790	6.4	90	115	2790	5.6	89	
23.22	146		2790	7.2	90	138	2790	6.8	90	121	2790	5.9	90	
20.37	167		2790	8.2	90	157	2790	7.8	90	137	2790	6.7	90	
17.28	197	2390	8.3	90	185	2570	8.3	90	162	2790	7.9	90		
15.60	218	2170	8.3	90	205	2300	8.3	90	179	2610	8.2	90		
13.73	248	1900	8.3	90	233	2040	8.3	90	204	2350	8.4	90		
12.96	262	1770	8.2	90	247	1900	8.2	90	216	2210	8.4	90		
11.03	308	1500	8.2	90	290	1620	8.3	90	254	1900	8.4	90		
10.03	339	1340	8.0	90	319	1450	8.2	90	279	1720	8.4	90		
8.69	391	1100	7.6	89	368	1210	7.9	90	322	1470	8.3	90		
7.56	450	840	6.8	88	423	990	7.5	89	370	1250	8.2	90		

All values reflect mechanical limits. Shaded area indicates additional thermal limitations where $P_{emax} = 7.5 \text{ HP}$ for continuous use.

2200 - 1400 rpm

02 961 097

S67														
i [ratio]	Worm ratio/ # starts	$n_e = 2200 \text{ rpm}$				$n_e = 1700 \text{ rpm}$				$n_e = 1400 \text{ rpm}$				
		n_a [rpm]	T_{amax} [lb-in]	P_e [HP]	η [%]	n_a [rpm]	T_{amax} [lb-in]	P_e [HP]	η [%]	n_a [rpm]	T_{amax} [lb-in]	P_e [HP]	η [%]	
217.41	42/1	10	4600	1.2	64	7.8	4600	0.93	62	6.4	4600	0.78	61	
190.11		12	4600	1.3	65	8.9	4600	1.0	63	7.4	4600	0.87	62	
180.60		12	4600	1.3	65	9.4	4600	1.1	63	7.8	4600	0.91	62	
158.45		14	4600	1.5	66	11	4600	1.2	64	8.8	4600	1.0	63	
134.40		16	4600	1.7	67	13	4600	1.5	65	10	4600	1.2	64	
121.33		18	4600	2.0	68	14	4600	1.6	66	12	4600	1.3	65	
106.75		21	4600	2.1	68	16	4600	1.7	67	13	4600	1.5	66	
100.80		22	4510	2.3	69	17	4600	1.9	67	14	4600	1.5	66	
85.83		26	4340	2.5	69	20	4600	2.1	68	16	4600	1.7	67	
78.00		28	4120	2.7	70	22	4510	2.3	69	18	4600	1.9	68	
67.57		33	3630	2.7	70	25	4380	2.5	69	21	4600	2.1	69	
58.80		37	3190	2.7	70	29	4070	2.7	70	24	4430	2.4	69	
75.06		29/2	29	4250	2.4	81	23	4250	1.9	79	19	4250	1.6	79
65.63			34	4250	2.8	81	26	4250	2.1	80	21	4250	1.9	79
62.35			35	4250	3.0	81	27	4250	2.3	80	22	4250	1.9	79
54.70			40	4250	3.4	82	31	4250	2.5	81	26	4250	2.1	80
46.40	47		4250	3.9	82	37	4250	3.1	82	30	4250	2.5	81	
41.89	53		4250	4.3	83	41	4250	3.4	82	33	4250	2.8	81	
36.85	60		4200	4.8	83	46	4250	3.8	82	38	4250	3.1	82	
34.80	63		3980	4.8	83	49	4250	4.0	83	40	4250	3.4	82	
29.63	74		3500	5.0	84	57	4250	4.7	83	47	4250	3.9	83	
26.93	82		3190	5.0	84	63	4030	4.8	83	52	4250	4.3	83	
23.33	94		2830	5.1	84	73	3580	5.0	84	60	4250	4.8	83	
20.30	108		2480	5.1	84	84	3190	5.1	84	69	3760	5.0	84	
24.44	27/5		90	3010	4.8	89	70	3010	3.8	88	57	3010	3.1	88
23.22			95	3010	5.1	89	73	3010	3.9	89	60	3010	3.2	88
20.37			108	3010	5.8	89	83	3010	4.4	89	69	3010	3.8	88
17.28			127	3010	6.7	90	98	3010	5.2	89	81	3010	4.3	89
15.60		141	3010	7.5	90	109	3010	5.8	89	90	3010	4.8	89	
13.73		160	2920	8.2	90	124	3010	6.6	90	102	3010	5.5	89	
12.96		170	2790	8.3	90	131	3010	7.0	90	108	3010	5.8	89	
11.03		199	2430	8.4	90	154	3010	8.2	90	127	3010	6.7	90	
10.03		219	2210	8.4	91	169	2790	8.3	90	140	3010	7.4	90	
8.69		253	1950	8.6	91	196	2480	8.4	91	161	2960	8.4	90	
7.56		291	1700	8.7	91	225	2210	8.7	91	185	2610	8.4	91	

All values reflect mechanical limits. Shaded area indicates additional thermal limitations where $P_{emax} = 7.5 \text{ HP}$ for continuous use.

1100 - 700 rpm

02 962 097

S67														
i [ratio]	Worm ratio/ # starts	$n_e = 1100 \text{ rpm}$				$n_e = 900 \text{ rpm}$				$n_e = 700 \text{ rpm}$				
		n_a [rpm]	T_{amax} [lb-in]	P_e [HP]	η [%]	n_a [rpm]	T_{amax} [lb-in]	P_e [HP]	η [%]	n_a [rpm]	T_{amax} [lb-in]	P_e [HP]	η [%]	
217.41	42/1	5.1	4910	0.67	59	4.1	4960	0.56	58	3.2	5040	0.46	56	
190.11		5.8	4910	0.75	60	4.7	4960	0.63	59	3.7	5000	0.51	57	
180.60		6.1	4910	0.79	61	5.0	4910	0.66	59	3.9	5000	0.54	57	
158.45		6.9	4870	0.87	62	5.7	4910	0.74	60	4.4	4960	0.59	58	
134.40		8.2	4870	1.0	63	6.7	4870	0.84	61	5.2	4910	0.68	60	
121.33		9.1	4870	1.1	63	7.4	4870	0.93	62	5.8	4910	0.75	60	
106.75		10	4870	1.2	64	8.4	4870	1.0	63	6.6	4910	0.83	61	
100.80		11	4870	1.3	65	8.9	4870	1.1	63	6.9	4910	0.89	62	
85.83		13	4870	1.5	66	10	4870	1.3	64	8.2	4870	1.0	63	
78.00		14	4870	1.6	66	12	4870	1.3	65	9.0	4870	1.1	63	
67.57		16	4870	1.9	67	13	4870	1.6	66	10	4870	1.2	64	
58.80		19	4690	2.0	68	15	4870	1.7	67	12	4870	1.3	65	
75.06		29/2	15	4650	1.3	77	12	4650	1.2	76	9.3	4650	0.91	75
65.63			17	4650	1.6	78	14	4650	1.3	77	11	4650	1.0	76
62.35	18		4650	1.6	78	14	4650	1.3	77	11	4650	1.1	76	
54.70	20		4650	1.9	79	16	4650	1.6	78	13	4650	1.2	77	
46.40	24		4650	2.1	80	19	4650	1.9	79	15	4650	1.5	78	
41.89	26		4650	2.4	80	21	4650	2.0	79	17	4650	1.6	78	
36.85	30		4650	2.7	81	24	4650	2.3	80	19	4650	1.7	79	
34.80	32		4650	2.8	81	26	4650	2.4	80	20	4650	1.9	79	
29.63	37		4650	3.4	82	30	4650	2.8	81	24	4650	2.1	80	
26.93	41		4650	3.6	82	33	4650	3.1	81	26	4650	2.4	80	
23.33	47		4650	4.2	83	39	4650	3.5	82	30	4650	2.7	81	
20.30	54		4600	4.7	83	44	4650	4.0	82	34	4650	3.1	81	
24.44	27/5		45	3140	2.5	87	37	3190	2.1	87	29	3230	1.7	86
23.22			47	3140	2.7	87	39	3190	2.3	87	30	3230	1.7	86
20.37		54	3140	3.1	88	44	3140	2.5	87	34	3230	2.0	86	
17.28		64	3140	3.6	88	52	3140	3.0	88	41	3190	2.4	87	
15.60		71	3100	3.9	88	58	3140	3.2	88	45	3140	2.5	87	
13.73		80	3100	4.4	89	66	3140	3.8	88	51	3140	3.0	88	
12.96		85	3100	4.7	89	69	3100	3.9	88	54	3140	3.1	88	
11.03		100	3100	5.5	89	82	3100	4.6	89	63	3140	3.6	88	
10.03		110	3050	5.9	90	90	3100	5.0	89	70	3140	3.9	88	
8.69		127	3050	6.8	90	104	3100	5.6	89	81	3100	4.4	89	
7.56		146	3050	7.8	90	119	3050	6.4	90	93	3100	5.1	89	

All values reflect mechanical limits. Shaded area indicates additional thermal limitations where $P_{emax} = 7.5 \text{ HP}$ for continuous use.

500 - 10 rpm

02 962 097

S67														
i [ratio]	Worm ratio/ # starts	$n_e = 500 \text{ rpm}$				$n_e = 250 \text{ rpm}$				$n_e = 10 \text{ rpm}$				
		n_a [rpm]	T_{amax} [lb-in]	P_e [HP]	η [%]	n_a [rpm]	T_{amax} [lb-in]	P_e [HP]	η [%]	n_a [rpm]	T_{amax} [lb-in]	P_e [HP]	η [%]	
217.41	42/1	2.3	5040	0.34	54	1.1	5040	0.17	51	0.05	5040	0.00	47	
190.11		2.6	5040	0.39	55	1.3	5040	0.20	51	0.05	5040	0.00	48	
180.60		2.8	5040	0.40	55	1.4	5040	0.21	51	0.06	5040	0.00	48	
158.45		3.2	5040	0.46	56	1.6	5040	0.24	52	0.06	5040	0.00	49	
134.40		3.7	5000	0.51	57	1.9	5040	0.28	53	0.07	5040	0.00	50	
121.33		4.1	4960	0.56	58	2.1	5040	0.31	53	0.08	5040	0.00	50	
106.75		4.7	4960	0.63	59	2.3	5040	0.35	54	0.09	5040	0.00	50	
100.80		5.0	4960	0.66	59	2.5	5040	0.36	55	0.10	5040	0.00	50	
85.83		5.8	4910	0.75	60	2.9	5040	0.42	56	0.12	5040	0.00	51	
78.00		6.4	4910	0.82	61	3.2	5040	0.46	56	0.13	5040	0.00	51	
67.57		7.4	4910	0.93	62	3.7	5000	0.51	57	0.15	5000	0.00	51	
58.80		8.5	4870	1.0	63	4.3	4960	0.58	58	0.17	4960	0.00	51	
75.06		29/2	6.7	5040	0.72	73	3.3	5040	0.38	70	0.13	5040	0.00	68
65.63			7.6	5040	0.82	74	3.8	5040	0.43	71	0.15	5040	0.00	68
62.35	8.0		5040	0.86	74	4.0	5040	0.46	71	0.16	5040	0.00	69	
54.70	9.1		5040	0.98	75	4.6	5040	0.51	71	0.18	5040	0.00	69	
46.40	11		5040	1.1	76	5.4	5040	0.59	72	0.22	5040	0.00	69	
41.89	12		5040	1.2	76	6.0	5040	0.66	73	0.24	5040	0.00	69	
36.85	14		5040	1.5	77	6.8	5040	0.74	73	0.27	5040	0.00	69	
34.80	14		5040	1.5	77	7.2	5040	0.78	74	0.29	5040	0.00	69	
29.63	17		5000	1.7	78	8.4	5040	0.91	75	0.34	5040	0.00	70	
26.93	19		5000	1.9	79	9.3	5040	0.99	75	0.37	5040	0.00	70	
23.33	21		5000	2.1	79	11	5040	1.1	76	0.43	5040	0.00	70	
20.30	25		5000	2.4	80	12	5040	1.3	77	0.49	5040	0.00	70	
24.44	27/5		20	3230	1.2	85	10	3140	0.62	82	0.41	3140	0.03	80
23.22			22	3230	1.3	85	11	3140	0.66	82	0.43	3140	0.00	80
20.37		25	3360	1.5	85	12	3230	0.76	83	0.49	3230	0.00	80	
17.28		29	3230	1.7	86	14	3850	1.1	83	0.58	3850	0.00	81	
15.60		32	3230	1.9	86	16	3810	1.2	84	0.64	3810	0.00	81	
13.73		36	3230	2.1	87	18	3670	1.3	84	0.73	3670	0.00	81	
12.96		39	3190	2.3	87	19	3630	1.3	84	0.77	3630	0.00	81	
11.03		45	3140	2.5	87	23	3450	1.5	85	0.91	3450	0.00	81	
10.03		50	3140	2.8	88	25	3360	1.6	85	1.0	3360	0.00	81	
8.69		58	3140	3.2	88	29	3270	1.7	86	1.2	3270	0.08	81	
7.56		66	3140	3.8	88	33	3230	2.0	86	1.3	3230	0.08	81	

11.10.5 S77

3400 - 2800 rpm

02 963 097

S77													
i [ratio]	Worm ratio/ # starts	$n_e = 3400 \text{ rpm}$				$n_e = 3200 \text{ rpm}$				$n_e = 2800 \text{ rpm}$			
		n_a [rpm]	T_{amax} [lb-in]	P_e [HP]	η [%]	n_a [rpm]	T_{amax} [lb-in]	P_e [HP]	η [%]	n_a [rpm]	T_{amax} [lb-in]	P_e [HP]	η [%]
256.47	40/1	13	10270	3.1	71	12	10270	2.8	71	11	10270	2.5	70
225.26		15	10000	3.4	72	14	10180	3.2	71	12	10270	2.8	71
214.00		16	9820	3.5	72	15	10090	3.4	71	13	10270	3.0	71
189.09		18	9560	3.8	72	17	9740	3.6	72	15	10090	3.4	71
161.60		21	9200	4.2	73	20	9290	4.0	73	17	9650	3.6	72
148.15		23	8940	4.4	73	22	9120	4.3	73	19	9470	3.9	73
130.00		26	8580	4.8	74	25	8760	4.7	74	22	9120	4.3	73
123.20		28	8410	5.0	74	26	8580	4.8	74	23	8940	4.4	73
107.83		32	7970	5.4	74	30	8140	5.2	74	26	8580	4.8	74
97.14		35	7610	5.6	75	33	7790	5.5	74	29	8230	5.1	74
85.22		40	6810	5.8	75	38	7260	5.8	75	33	7790	5.5	75
75.20		45	5970	5.8	74	43	6420	5.8	75	37	7350	5.8	75
66.67		51	5180	5.6	74	48	5620	5.8	75	42	6590	5.9	75
56.92		60	4290	5.5	73	56	4690	5.6	74	49	5620	5.9	75
75.09		45	9030	7.5	86	43	9030	7.1	86	37	9030	6.2	86
71.33	48	9030	7.9	87	45	9030	7.4	86	39	9030	6.6	86	
63.03	54	9030	8.9	87	51	9030	8.3	87	44	9030	7.4	86	
53.87	63	8670	9.9	87	59	8850	9.5	87	52	9030	8.6	87	
49.38	69	8410	10.5	87	65	8580	10.1	87	57	8940	9.3	87	
43.33	78	8050	11.4	88	74	8230	11.0	88	65	8580	10.1	87	
41.07	40/3	83	7970	11.9	88	78	8050	11.4	88	68	8410	10.5	87
35.94		95	7080	12.1	88	89	7520	12.1	88	78	8050	11.4	88
32.38		105	6420	12.2	88	99	6810	12.2	88	86	7790	12.2	88
28.41		120	5620	12.2	88	113	6020	12.2	88	99	6900	12.2	88
25.07		136	4960	12.2	88	128	5310	12.2	88	112	6150	12.3	88
22.22	153	4290	11.9	88	144	4650	12.1	88	126	5440	12.3	88	
18.97	179	3500	11.4	87	169	3890	11.9	88	148	4600	12.2	88	
22.89	149	5220	13.4	91	140	5220	12.7	91	122	5220	11.1	91	
20.99	162	5220	14.6	92	152	5220	13.8	92	133	5220	12.1	91	
18.42	185	5220	16.6	92	174	5220	15.7	92	152	5220	13.8	92	
17.45	195	5220	17.6	92	183	5220	16.6	92	160	5220	14.5	92	
15.28	34/6	223	4690	18.1	92	209	4960	18.0	92	183	5220	16.5	92
13.76		247	4250	18.1	92	233	4470	18.0	92	203	5180	18.2	92
12.07		282	3670	17.8	92	265	3940	18.0	92	232	4560	18.2	92
10.65		319	3230	17.8	92	300	3450	18.0	92	263	4030	18.2	92
9.44		360	2790	17.4	92	339	3050	17.8	92	297	3580	18.4	92
8.06	422	2300	16.9	91	397	2520	17.3	92	347	3010	18.1	92	

All values reflect mechanical limits. Shaded area indicates additional thermal limitations where $P_{emax} = 12.3 \text{ HP}$ for continuous use.

2200 - 1400 rpm

02 963 097

S77													
i [ratio]	Worm ratio/ # starts	$n_e = 2200 \text{ rpm}$				$n_e = 1700 \text{ rpm}$				$n_e = 1400 \text{ rpm}$			
		n_a [rpm]	T_{amax} [lb-in]	P_e [HP]	η [%]	n_a [rpm]	T_{amax} [lb-in]	P_e [HP]	η [%]	n_a [rpm]	T_{amax} [lb-in]	P_e [HP]	η [%]
256.47	40/1	8.6	11150	2.1	69	6.6	11240	1.7	67	5.5	11240	1.5	66
225.26		9.8	10890	2.4	69	7.5	11240	2.0	68	6.2	11240	1.6	67
214.00		10	10800	2.5	70	7.9	11240	2.1	68	6.5	11240	1.7	67
189.09		12	10620	2.8	70	9.0	10970	2.3	69	7.4	11240	2.0	68
161.60		14	10270	3.1	71	11	10800	2.5	70	8.7	11150	2.3	69
148.15		15	10090	3.4	72	11	10620	2.8	70	9.4	10970	2.4	69
130.00		17	9740	3.6	72	13	10350	3.1	71	11	10710	2.5	70
123.20		18	9560	3.8	73	14	10180	3.1	71	11	10620	2.7	70
107.83		20	9200	4.0	73	16	9820	3.4	72	13	10350	3.0	71
97.14		23	8940	4.4	74	18	9650	3.8	73	14	10090	3.2	72
85.22		26	8580	4.7	74	20	9290	4.0	73	16	9740	3.5	72
75.20		29	8140	5.1	74	23	8940	4.3	74	19	9470	3.9	73
66.67		33	7790	5.5	75	25	8580	4.7	74	21	9200	4.2	73
56.92		39	7350	6.0	75	30	8140	5.2	75	25	8760	4.6	74
75.09		29	9740	5.4	85	23	9740	4.2	84	19	9740	3.5	83
71.33		31	9740	5.6	85	24	9740	4.3	85	20	9740	3.6	84
63.03		35	9740	6.3	86	27	9740	5.0	85	22	9740	4.0	84
53.87		41	9740	7.4	86	32	9740	5.8	86	26	9740	4.7	85
49.38	45	9560	7.8	87	34	9740	6.2	86	28	9740	5.1	85	
43.33	51	9290	8.6	87	39	9740	7.0	86	32	9740	5.8	86	
41.07	40/3	54	9120	8.9	87	41	9740	7.4	86	34	9740	6.2	86
35.94		61	8670	9.7	87	47	9380	8.2	87	39	9740	7.0	86
32.38		68	8500	10.5	88	53	9200	8.9	87	43	9650	7.6	87
28.41		77	8140	11.4	88	60	8760	9.5	87	49	9290	8.3	87
25.07		88	7700	12.2	88	68	8500	10.5	88	56	9030	9.1	87
22.22		99	6990	12.5	88	77	8140	11.3	88	63	8670	9.9	87
18.97		116	6020	12.6	88	90	7610	12.3	88	74	8230	11.0	88
22.89		96	6280	10.6	91	74	6240	8.2	90	61	6240	6.7	90
20.99		105	6280	11.5	91	81	6240	8.9	91	67	6240	7.4	90
18.42		119	6370	13.3	91	92	6280	10.2	91	76	6240	8.3	90
17.45	126	6370	13.9	91	97	6280	10.7	91	80	6280	8.9	91	
15.28	144	6370	16.0	92	111	6370	12.3	91	92	6280	10.1	91	
13.76	34/6	160	6420	17.7	92	124	6370	13.7	91	102	6280	11.1	91
12.07		182	5750	18.1	92	141	6420	15.7	92	116	6370	12.9	91
10.65		207	5130	18.2	92	160	6420	17.7	92	131	6370	14.5	92
9.44		233	4600	18.5	92	180	5800	18.0	92	148	6420	16.5	92
8.06		273	3940	18.5	92	211	5090	18.5	92	174	6020	18.1	92

All values reflect mechanical limits. Shaded area indicates additional thermal limitations where $P_{emax} = 12.3 \text{ HP}$ for continuous use.

11

1100 - 700 rpm

02 964 097

S77													
i [ratio]	Worm ratio/ # starts	n _e = 1100 rpm				n _e = 900 rpm				n _e = 700 rpm			
		n _a [rpm]	T _{amax} [lb-in]	P _e [HP]	η [%]	n _a [rpm]	T _{amax} [lb-in]	P _e [HP]	η [%]	n _a [rpm]	T _{amax} [lb-in]	P _e [HP]	η [%]
256.47	40/1	4.3	11240	1.2	64	3.5	11240	1.0	63	2.7	11240	0.80	61
225.26		4.9	11240	1.3	65	4.0	11240	1.1	63	3.1	11240	0.90	62
214.00		5.1	11240	1.3	65	4.2	11240	1.2	64	3.3	11240	0.94	62
189.09		5.8	11240	1.6	66	4.8	11240	1.3	65	3.7	11240	1.0	63
161.60		6.8	11240	1.7	67	5.6	11240	1.5	66	4.3	11240	1.2	64
148.15		7.4	11240	2.0	68	6.1	11240	1.6	66	4.7	11240	1.3	65
130.00		8.5	11150	2.1	69	6.9	11240	1.9	67	5.4	11240	1.5	66
123.20		8.9	11060	2.3	69	7.3	11240	1.9	68	5.7	11240	1.5	66
107.83		10	10800	2.5	70	8.3	11150	2.1	69	6.5	11240	1.7	67
97.14		11	10620	2.7	70	9.3	11060	2.4	69	7.2	11240	1.9	68
85.22		13	10350	3.0	71	11	10800	2.5	70	8.2	11240	2.1	69
75.20		15	10090	3.2	72	12	10530	2.8	71	9.3	11060	2.4	69
66.67		16	9820	3.5	72	13	10270	3.1	71	10	10800	2.5	70
56.92		19	9380	3.9	73	16	9910	3.5	72	12	10530	3.0	71
75.09		15	9910	2.8	83	12	10000	2.3	82	9.3	10350	1.9	81
71.33		15	9910	3.0	83	13	10000	2.4	82	9.8	9910	1.9	81
63.03		17	9910	3.4	83	14	9910	2.7	82	11	10000	2.1	81
53.87		20	9910	3.9	84	17	9910	3.2	83	13	9910	2.5	82
49.38		22	9910	4.2	84	18	9910	3.5	83	14	9910	2.7	82
43.33	25	10000	4.7	85	21	9910	3.9	84	16	9910	3.1	83	
41.07	40/3	27	10000	5.0	85	22	9910	4.2	84	17	9910	3.2	83
35.94		31	10180	5.8	85	25	10000	4.7	85	19	9910	3.6	84
32.38		34	10000	6.3	86	28	10000	5.2	85	22	9910	4.0	84
28.41		39	9820	7.0	86	32	10180	6.0	86	25	10000	4.6	85
25.07		44	9560	7.6	87	36	9910	6.6	86	28	10000	5.2	85
22.22		50	9290	8.4	87	41	9740	7.2	86	32	10180	5.9	86
18.97		58	8940	9.4	87	47	9380	8.2	87	37	9910	6.7	86
22.89		48	6150	5.2	89	39	6150	4.3	89	31	6240	3.5	88
20.99		52	6240	5.8	90	43	6150	4.7	89	33	6240	3.8	88
18.42		60	6200	6.6	90	49	6200	5.4	89	38	6200	4.2	89
17.45	63	6200	6.8	90	52	6200	5.6	90	40	6200	4.4	89	
15.28	34/6	72	6280	7.9	90	59	6200	6.4	90	46	6200	5.1	89
13.76		80	6280	8.9	91	65	6200	7.1	90	51	6200	5.6	90
12.07		91	6280	10.1	91	75	6280	8.2	90	58	6200	6.3	90
10.65		103	6330	11.4	91	85	6280	9.3	91	66	6280	7.2	90
9.44		117	6370	12.9	91	95	6330	10.5	91	74	6280	8.2	90
8.06		136	6420	15.2	92	112	6370	12.3	91	87	6280	9.5	91

All values reflect mechanical limits. Shaded area indicates additional thermal limitations where P_{emax} = 12.3 HP for continuous use.

500 - 10 rpm

02 964 097

S77													
i [ratio]	Worm ratio/ # starts	$n_e = 500 \text{ rpm}$				$n_e = 250 \text{ rpm}$				$n_e = 10 \text{ rpm}$			
		n_a [rpm]	T_{amax} [lb-in]	P_e [HP]	η [%]	n_a [rpm]	T_{amax} [lb-in]	P_e [HP]	η [%]	n_a [rpm]	T_{amax} [lb-in]	P_e [HP]	η [%]
256.47	40/1	1.9	11240	0.59	59	0.97	11240	0.31	56	0.04	11240	0.00	54
225.26		2.2	11240	0.66	60	1.1	11240	0.35	56	0.04	11240	0.00	55
214.00		2.3	11240	0.70	60	1.2	11240	0.38	56	0.05	11240	0.00	55
189.09		2.6	11240	0.78	61	1.3	11240	0.42	57	0.05	11240	0.00	55
161.60		3.1	11240	0.90	62	1.5	11240	0.48	58	0.06	11240	0.00	55
148.15		3.4	11240	0.97	62	1.7	11240	0.52	58	0.07	11240	0.00	55
130.00		3.8	11240	1.1	63	1.9	11240	0.58	59	0.08	11240	0.00	55
123.20		4.1	11240	1.1	64	2.0	11240	0.62	59	0.08	11240	0.00	55
107.83		4.6	11240	1.3	65	2.3	11240	0.68	60	0.09	11240	0.00	56
97.14		5.1	11240	1.3	65	2.6	11240	0.75	61	0.10	11240	0.00	56
85.22		5.9	11240	1.6	66	2.9	11240	0.84	62	0.12	11240	0.00	56
75.20		6.6	11240	1.7	67	3.3	11240	0.95	62	0.13	11240	0.00	56
66.67		7.5	11240	2.0	68	3.7	11240	1.1	63	0.15	11240	0.00	56
56.92		8.8	11150	2.3	69	4.4	11240	1.2	64	0.18	11240	0.00	56
75.09		6.7	10270	1.3	79	3.3	9910	0.68	76	0.13	9910	0.00	75
71.33		7.0	9820	1.3	79	3.5	9380	0.68	77	0.14	9380	0.00	75
63.03		7.9	10890	1.7	80	4.0	10620	0.87	77	0.16	10620	0.00	76
53.87		9.3	10440	1.9	81	4.6	10970	1.0	78	0.19	10970	0.00	76
49.38	10	10270	2.0	81	5.1	10970	1.1	78	0.20	10970	0.00	76	
43.33	12	9910	2.3	82	5.8	10970	1.3	79	0.23	10970	0.00	76	
41.07	40/3	12	9910	2.3	82	6.1	10970	1.3	79	0.24	10970	0.00	76
35.94		14	9910	2.7	82	7.0	10970	1.5	79	0.28	10970	0.00	76
32.38		15	9910	3.0	83	7.7	10970	1.7	80	0.31	10970	0.07	76
28.41		18	9910	3.4	83	8.8	10530	1.9	80	0.35	10530	0.08	76
25.07		20	9910	3.8	84	10	10350	2.0	81	0.40	10350	0.08	76
22.22		23	10000	4.3	84	11	10000	2.1	81	0.45	10000	0.09	76
18.97	26	10000	5.0	85	13	9910	2.5	82	0.53	9910	0.11	76	
22.89	22	6110	2.4	87	11	5970	1.2	85	0.44	5970	0.00	83	
20.99	24	6420	2.8	87	12	6550	1.5	85	0.48	6550	0.00	83	
18.42	27	6240	3.1	88	14	7350	1.9	86	0.54	7350	0.08	83	
17.45	29	6240	3.2	88	14	7170	1.9	86	0.57	7170	0.08	83	
15.28	34/6	33	6240	3.6	88	16	6950	2.1	86	0.65	6950	0.08	83
13.76		36	6150	4.0	89	18	6810	2.3	87	0.73	6810	0.09	83
12.07		41	6150	4.6	89	21	6640	2.5	87	0.83	6640	0.11	83
10.65		47	6150	5.1	89	23	6420	2.7	87	0.94	6420	0.12	83
9.44		53	6240	5.9	90	26	6240	3.0	88	1.1	6240	0.12	83
8.06		62	6240	6.8	90	31	6240	3.5	88	1.2	6240	0.15	83

11

11.10.6 S87

3400 - 2800 rpm

02 965 097

S87														
i [ratio]	Worm ratio/ # starts	$n_e = 3400 \text{ rpm}$				$n_e = 3200 \text{ rpm}$				$n_e = 2800 \text{ rpm}$				
		n_a [rpm]	T_{amax} [lb-in]	P_e [HP]	η [%]	n_a [rpm]	T_{amax} [lb-in]	P_e [HP]	η [%]	n_a [rpm]	T_{amax} [lb-in]	P_e [HP]	η [%]	
288.00	40/1	12	17970	4.6	74	11	18320	4.4	73	9.7	18320	3.9	73	
258.18		13	17610	5.0	74	12	17790	4.7	74	11	18320	4.3	73	
222.40		15	16900	5.5	75	14	17260	5.4	74	13	17790	4.8	74	
202.96		17	16370	5.8	75	16	16730	5.6	75	14	17430	5.1	74	
180.00		19	15930	6.3	75	18	16200	6.0	75	16	16900	5.6	75	
151.30		22	14960	7.1	75	21	15310	6.8	75	19	15930	6.2	75	
139.05		24	14430	7.4	76	23	14870	7.2	76	20	15580	6.6	75	
123.48		28	13890	8.0	76	26	14160	7.6	76	23	14960	7.1	76	
110.40		31	12660	8.2	76	29	13630	8.3	76	25	14340	7.6	76	
99.26		34	11150	8.0	75	32	12210	8.3	76	28	13720	8.0	76	
86.15		39	9120	7.8	74	37	10180	8.0	75	33	12300	8.3	76	
77.14		44	7350	7.1	72	41	8580	7.6	74	36	10800	8.2	76	
64.00		53	4430	5.8	65	50	5490	6.3	68	44	8500	7.9	75	
91.20		38/3	37	13010	8.9	88	35	13010	8.3	87	31	13010	7.2	87
81.76			42	13010	9.8	88	39	13010	9.3	88	34	13010	8.0	87
70.43			48	13010	11.3	88	45	13010	10.6	88	40	13010	9.4	88
64.27	53		13010	12.3	88	50	13010	11.7	88	44	13010	10.2	88	
57.00	60		13010	13.9	88	56	13010	13.1	88	49	13010	11.5	88	
47.91	71		13010	16.5	89	67	13010	15.6	89	58	13010	13.7	88	
44.03	77		13010	18.0	89	73	13010	16.9	89	64	13010	14.8	89	
39.10	87		11510	17.8	89	82	12390	18.1	89	72	13010	16.6	89	
34.96	97		10090	17.6	89	92	10970	18.0	89	80	12740	18.2	89	
31.43	108		8850	17.2	88	102	9650	17.6	89	89	11420	18.1	89	
27.28	125		7170	16.2	88	117	8050	17.0	88	103	9820	18.0	89	
24.43	139		5840	14.9	87	131	6860	16.2	88	115	8500	17.4	89	
20.27	168		3500	11.3	82	158	4340	12.9	84	138	6680	16.6	88	
25.50	34/6		133	8760	20	92	125	8760	18.9	92	110	8760	16.6	92
21.43			159	8760	24	92	149	8760	23	92	131	8760	19.7	92
19.70			173	8760	25	92	162	8760	25	92	142	8760	21	92
17.49		194	7700	25	92	183	8230	25	92	160	8760	24	92	
15.64		217	6730	25	92	205	7350	25	92	179	8500	25	92	
14.06		242	5840	24	92	228	6420	25	92	199	7610	25	92	
12.21		278	4780	23	91	262	5350	24	92	229	6460	25	92	
10.93		311	3890	21	90	293	4510	23	91	256	5710	25	92	
9.07		375	2260	15.4	87	353	2880	18.1	89	309	4430	24	92	
7.88		431	1770	14.1	86	406	2040	15.2	87	355	3320	21	90	

All values reflect mechanical limits. Shaded area indicates additional thermal limitations where $P_{emax} = 20 \text{ HP}$ for continuous use.

2200 - 1400 rpm

02 965 097

S87													
i [ratio]	Worm ratio/ # starts	$n_e = 2200$ rpm				$n_e = 1700$ rpm				$n_e = 1400$ rpm			
		n_a [rpm]	T_{amax} [lb-in]	P_e [HP]	η [%]	n_a [rpm]	T_{amax} [lb-in]	P_e [HP]	η [%]	n_a [rpm]	T_{amax} [lb-in]	P_e [HP]	η [%]
288.00	40/1	7.6	19560	3.4	71	5.9	20180	2.7	70	4.9	20180	2.3	69
258.18		8.5	19200	3.6	72	6.6	20000	3.0	71	5.4	20180	2.5	69
222.40		9.9	18850	4.0	73	7.6	19560	3.4	71	6.3	20180	2.8	70
202.96		11	18410	4.3	73	8.4	19380	3.6	72	6.9	20000	3.1	71
180.00		12	17880	4.7	74	9.4	18850	3.9	73	7.8	19560	3.4	72
151.30		15	17170	5.4	75	11	18230	4.4	74	9.3	19030	3.9	73
139.05		16	16640	5.6	75	12	17880	4.7	74	10	18590	4.0	73
123.48		18	16110	6.0	75	14	17350	5.1	74	11	18230	4.4	74
110.40		20	15660	6.6	76	15	16820	5.5	75	13	17700	4.8	74
99.26		22	15050	7.0	76	17	16280	5.9	75	14	17350	5.2	75
86.15		26	14340	7.6	76	20	15660	6.4	76	16	16640	5.8	75
77.14		29	13630	8.0	76	22	15050	7.0	76	18	16110	6.2	76
64.00		34	12040	8.6	77	27	13980	7.6	77	22	15050	6.8	76
91.20		24	13630	6.0	87	19	13450	4.7	86	15	13360	3.9	85
81.76		27	14160	7.0	87	21	14160	5.4	86	17	14160	4.6	86
70.43		31	14160	8.0	87	24	14160	6.3	87	20	14160	5.2	86
64.27		34	14160	8.9	88	26	14160	6.8	87	22	14160	5.6	86
57.00		39	14160	9.9	88	30	14160	7.6	87	25	14160	6.4	87
47.91	46	14160	11.7	88	35	14160	9.1	88	29	14160	7.5	87	
44.03	38/3	50	14160	12.7	88	39	14160	9.9	88	32	14160	8.2	87
39.10		56	14160	14.2	89	43	14160	11.1	88	36	14160	9.1	88
34.96		63	14160	16.0	89	49	14160	12.3	88	40	14160	10.2	88
31.43		70	14160	17.7	89	54	14160	13.7	89	45	14160	11.4	88
27.28		81	12830	18.4	89	62	14160	15.7	89	51	14160	13.0	89
24.43		90	11590	18.5	89	70	14160	17.6	89	57	14160	14.5	89
20.27	109	9560	18.5	89	84	12570	18.8	89	69	14160	17.4	89	
25.50	86	10970	16.4	92	67	10970	12.7	91	55	10970	10.5	91	
21.43	103	10970	19.4	92	79	10970	15.0	92	65	10970	12.5	91	
19.70	112	10970	21	92	86	10970	16.4	92	71	10970	13.5	91	
17.49	126	10970	24	92	97	10970	18.4	92	80	10970	15.2	92	
15.64	34/6	141	10890	27	92	109	10970	21	92	90	10970	17.0	92
14.06		156	9820	27	92	121	10970	23	92	100	10970	18.9	92
12.21		180	8580	27	93	139	10970	27	92	115	10970	22	92
10.93		201	7700	27	93	156	10000	27	93	128	10970	24	92
9.07		243	6370	27	92	187	8410	27	93	154	10090	27	93
7.88		279	5350	25	92	216	7350	27	93	178	8940	27	93

All values reflect mechanical limits. Shaded area indicates additional thermal limitations where $P_{emax} = 20$ HP for continuous use.

1100 - 700 rpm

02 966 097

S87													
i [ratio]	Worm ratio/ # starts	n _e = 1100 rpm				n _e = 900 rpm				n _e = 700 rpm			
		n _a [rpm]	T _{amax} [lb-in]	P _e [HP]	η [%]	n _a [rpm]	T _{amax} [lb-in]	P _e [HP]	η [%]	n _a [rpm]	T _{amax} [lb-in]	P _e [HP]	η [%]
288.00	40/1	3.8	21240	1.9	67	3.1	21680	1.6	66	2.4	21950	1.3	64
258.18		4.3	21060	2.1	68	3.5	21510	1.7	67	2.7	21860	1.5	65
222.40		4.9	20800	2.4	69	4.0	21240	2.0	68	3.1	21680	1.6	66
202.96		5.4	20620	2.5	70	4.4	21060	2.1	68	3.4	21510	1.7	67
180.00		6.1	20180	2.8	70	5.0	20800	2.4	69	3.9	21240	1.9	68
151.30		7.3	19820	3.2	71	5.9	20440	2.7	70	4.6	20800	2.3	69
139.05		7.9	19380	3.4	72	6.5	20000	3.0	71	5.0	20620	2.4	69
123.48		8.9	19030	3.8	73	7.3	19820	3.2	71	5.7	20440	2.7	70
110.40		10	18670	4.0	73	8.2	19380	3.5	72	6.3	20180	2.8	71
99.26		11	18320	4.4	74	9.1	19030	3.8	73	7.1	19820	3.1	71
86.15		13	17700	4.8	74	10	18500	4.2	73	8.1	19380	3.5	72
77.14		14	17170	5.2	75	12	18050	4.6	74	9.1	19030	3.8	73
64.00		17	16280	5.9	76	14	17350	5.2	75	11	18320	4.3	74
91.20		12	13190	3.0	84	9.9	13100	2.4	83	7.7	12920	1.9	82
81.76	13	15580	3.9	85	11	15580	3.2	84	8.6	15580	2.5	83	
70.43	16	15580	4.6	85	13	15580	3.8	85	9.9	15580	3.0	83	
64.27	17	15580	5.0	86	14	15580	4.0	85	11	15580	3.2	84	
57.00	19	15580	5.5	86	16	15580	4.6	85	12	15580	3.6	84	
47.91	38/3	23	15580	6.6	87	19	15580	5.4	86	15	15580	4.3	85
44.03		25	15580	7.1	87	20	15580	5.9	86	16	15580	4.6	85
39.10		28	15580	8.0	87	23	15580	6.6	87	18	15580	5.2	86
34.96		31	15580	8.9	88	26	15580	7.4	87	20	15580	5.8	86
31.43		35	15580	9.9	88	29	15580	8.2	87	22	15580	6.3	87
27.28		40	15580	11.3	88	33	15580	9.3	88	26	15580	7.2	87
24.43		45	15580	12.6	88	37	15580	10.3	88	29	15580	8.0	87
20.27		54	15580	15.2	89	44	15580	12.5	88	35	15580	9.7	88
25.50		43	11860	9.0	90	35	11860	7.4	90	27	11860	5.8	89
21.43		51	11860	10.6	91	42	11860	8.7	90	33	11860	6.8	90
19.70	56	11860	11.5	91	46	11860	9.5	91	36	11860	7.4	90	
17.49	63	11860	13.0	91	51	11860	10.6	91	40	11860	8.3	90	
15.64	34/6	70	11860	14.5	92	58	11860	11.9	91	45	11860	9.3	91
14.06		78	11860	16.1	92	64	11860	13.1	91	50	11860	10.3	91
12.21		90	11860	18.5	92	74	11860	15.2	92	57	11860	11.8	91
10.93		101	11860	21	92	82	11860	16.9	92	64	11860	13.1	91
9.07		121	11860	25	92	99	11860	20	92	77	11860	15.8	92
7.88		140	11150	27	93	114	11860	23	92	89	11860	18.2	92

All values reflect mechanical limits. Shaded area indicates additional thermal limitations where P_{emax} = 20 HP for continuous use.

500 - 10 rpm

02 966 097

S87													
i [ratio]	Worm ratio/ # starts	$n_e = 500 \text{ rpm}$				$n_e = 250 \text{ rpm}$				$n_e = 10 \text{ rpm}$			
		n_a [rpm]	T_{amax} [lb-in]	P_e [HP]	η [%]	n_a [rpm]	T_{amax} [lb-in]	P_e [HP]	η [%]	n_a [rpm]	T_{amax} [lb-in]	P_e [HP]	η [%]
288.00	40/1	1.7	22130	0.98	62	0.87	22130	0.51	59	0.03	22130	0.00	58
258.18		1.9	22130	1.1	63	0.97	22130	0.58	59	0.04	22130	0.00	58
222.40		2.2	22130	1.2	64	1.1	22130	0.66	60	0.04	22130	0.00	59
202.96		2.5	21950	1.3	64	1.2	22130	0.71	61	0.05	22130	0.00	59
180.00		2.8	21950	1.5	65	1.4	22130	0.80	61	0.06	22130	0.00	59
151.30		3.3	21510	1.7	67	1.7	22130	0.94	62	0.07	22130	0.00	59
139.05		3.6	21510	1.9	67	1.8	22130	1.0	63	0.07	22130	0.00	59
123.48		4.0	21240	2.0	68	2.0	22130	1.1	63	0.08	22130	0.00	59
110.40		4.5	21060	2.1	69	2.3	22130	1.2	64	0.09	22130	0.00	59
99.26		5.0	20620	2.4	69	2.5	21860	1.3	65	0.10	21860	0.00	59
86.15		5.8	20440	2.7	70	2.9	21680	1.5	66	0.12	21680	0.07	59
77.14		6.5	20000	3.0	71	3.2	21510	1.6	66	0.13	21510	0.08	59
64.00		7.8	19650	3.4	72	3.9	21240	2.0	68	0.16	21240	0.09	59
91.20		5.5	12830	1.3	81	2.7	12300	0.68	79	0.11	12300	0.00	78
81.76		6.1	17350	2.0	82	3.1	16640	1.0	79	0.12	16640	0.00	78
70.43		7.1	17520	2.4	82	3.5	17520	1.2	80	0.14	17520	0.00	79
64.27		7.8	17520	2.7	83	3.9	17520	1.3	80	0.16	17520	0.00	79
57.00		8.8	17520	3.0	83	4.4	17520	1.5	80	0.18	17520	0.00	79
47.91	38/3	10	17520	3.5	84	5.2	17520	1.7	81	0.21	17520	0.08	79
44.03		11	17520	3.8	84	5.7	17520	1.9	81	0.23	17520	0.08	79
39.10		13	17520	4.2	85	6.4	17520	2.1	82	0.26	17520	0.09	79
34.96		14	17520	4.7	85	7.2	17520	2.4	82	0.29	17520	0.11	79
31.43		16	17520	5.2	85	8.0	17520	2.7	83	0.32	17520	0.11	79
27.28		18	17520	5.9	86	9.2	17520	3.1	83	0.37	17520	0.13	79
24.43		20	17520	6.6	86	10	17520	3.4	84	0.41	17520	0.15	79
20.27		25	17520	7.9	87	12	17520	4.0	85	0.49	17520	0.17	79
25.50		20	12660	4.4	88	9.8	12300	2.1	87	0.39	12300	0.09	85
21.43		23	12570	5.2	89	12	13360	2.8	87	0.47	13360	0.12	85
19.70	25	12480	5.6	89	13	13890	3.2	87	0.51	13890	0.13	85	
17.49	29	12300	6.2	89	14	13890	3.6	88	0.57	13890	0.15	85	
15.64	34/6	32	12300	7.0	90	16	13630	3.9	88	0.64	13630	0.16	85
14.06		36	12300	7.6	90	18	13360	4.3	88	0.71	13360	0.17	85
12.21		41	12300	8.9	90	20	12920	4.7	89	0.82	12920	0.20	85
10.93		46	12300	9.8	91	23	12660	5.2	89	0.91	12660	0.21	85
9.07		55	12480	11.9	91	28	12300	6.0	89	1.1	12300	0.25	85
7.88		63	12480	13.8	91	32	12300	6.8	90	1.3	12300	0.30	85

11.10.7 S97

3400 - 2800 rpm

02 967 097

S97													
i [ratio]	Worm ratio/ # starts	$n_e = 3400 \text{ rpm}$				$n_e = 3200 \text{ rpm}$				$n_e = 2800 \text{ rpm}$			
		n_a [rpm]	T_{amax} [lb-in]	P_e [HP]	η [%]	n_a [rpm]	T_{amax} [lb-in]	P_e [HP]	η [%]	n_a [rpm]	T_{amax} [lb-in]	P_e [HP]	η [%]
286.40	40/1	12	31150	7.8	76	11	31770	7.5	76	9.8	32750	6.7	75
262.22		13	30530	8.3	76	12	31150	7.9	76	11	32130	7.2	75
231.67		15	29290	9.0	76	14	29910	8.6	76	12	31150	7.9	76
196.52		17	27610	9.9	77	16	28410	9.7	76	14	29650	8.9	76
180.95		19	26820	10.5	77	18	27610	10.1	77	15	28760	9.3	76
161.74		21	25750	11.1	77	20	26280	10.7	77	17	27610	9.9	77
145.60		23	24430	11.8	77	22	25220	11.4	77	19	26550	10.6	77
131.85		26	23540	12.6	77	24	24250	12.2	77	21	25490	11.1	77
116.92		29	20530	12.5	76	27	22570	12.7	77	24	24250	11.9	77
105.71		32	17520	11.9	75	30	19560	12.3	76	26	23280	12.7	77
89.60		38	11330	9.8	70	36	14780	11.4	74	31	19560	12.6	77
78.26		43	8140	8.6	65	41	9200	9.0	67	36	15660	11.8	75
65.45	52	5970	7.9	63	49	6860	8.3	64	43	9120	9.1	68	
80.85	37/3	42	27880	21	89	40	27880	19.6	89	35	27880	17.2	89
71.43		48	27350	23	90	45	27880	22	89	39	27880	19.4	89
60.59		56	25750	25	90	53	26280	25	90	46	27610	23	90
55.79		61	24960	27	90	57	25490	25	90	50	26820	24	90
49.87		68	23980	30	90	64	24430	28	90	56	25750	25	90
44.89		76	21510	28	90	71	23280	30	90	62	24690	27	90
40.65		84	19200	28	90	79	20800	30	90	69	23720	28	90
36.05		94	16200	27	89	89	17880	28	89	78	21240	30	90
32.60		104	13810	25	89	98	15580	27	89	86	19030	30	90
27.63		123	8940	20	86	116	11680	24	88	101	15400	28	89
24.13		141	6420	17.3	83	133	7260	18.2	84	116	12300	25	88
26.39		129	15490	34	93	121	15490	32	93	106	15490	28	93
23.59	144	15490	38	93	136	15490	36	93	119	15490	31	93	
21.23	160	15490	43	93	151	15490	40	93	132	15490	35	93	
19.23	177	13720	42	93	166	14870	42	93	146	15490	39	93	
17.05	199	11680	40	93	188	12830	42	93	164	15310	43	93	
15.42	220	9820	38	92	208	11150	40	93	182	13630	42	93	
13.07	260	6420	30	90	245	8320	35	92	214	10970	40	93	
11.41	298	4560	25	88	280	5180	25	89	245	8850	38	92	
9.55	356	3320	22	87	335	3850	23	87	293	5130	27	89	
8.26	412	2570	19.7	85	387	2960	21	86	339	4030	25	88	

All values reflect mechanical limits. Shaded area indicates additional thermal limitations where $P_{emax} = 30 \text{ HP}$ for continuous use.

2200 - 1400 rpm

02 967 097

S97														
i [ratio]	Worm ratio/ # starts	$n_e = 2200$ rpm				$n_e = 1700$ rpm				$n_e = 1400$ rpm				
		n_a [rpm]	T_{amax} [lb-in]	P_e [HP]	η [%]	n_a [rpm]	T_{amax} [lb-in]	P_e [HP]	η [%]	n_a [rpm]	T_{amax} [lb-in]	P_e [HP]	η [%]	
286.40	40/1	7.7	34690	5.6	74	5.9	35400	4.6	73	4.9	35400	3.9	72	
262.22		8.4	33980	6.0	75	6.5	35400	5.0	73	5.3	35400	4.2	72	
231.67		9.5	33360	6.7	75	7.3	35050	5.5	74	6.0	35400	4.7	73	
196.52		11	31680	7.4	76	8.7	33980	6.3	75	7.1	35400	5.4	74	
180.95		12	31060	7.9	76	9.4	33360	6.6	75	7.7	34690	5.8	74	
161.74		14	30180	8.6	76	11	32300	7.1	76	8.7	33980	6.3	75	
145.60		15	28940	9.1	77	12	31420	7.6	76	9.6	33010	6.7	75	
131.85		17	28050	9.7	77	13	30440	8.2	76	11	32300	7.2	76	
116.92		19	26730	10.3	77	15	29560	8.9	77	12	31060	7.8	76	
105.71		21	25930	11.1	77	16	28410	9.4	77	13	30440	8.3	76	
89.60		25	24160	12.2	77	19	26730	10.5	77	16	28670	9.3	77	
78.26		28	22480	12.9	78	22	25400	11.3	78	18	27260	10.1	77	
65.45		34	18760	13.0	77	26	23450	12.3	78	21	25670	11.1	78	
80.85		37/3	27	29210	14.2	89	21	28940	11.0	88	17	28590	9.0	88
71.43			31	29210	16.1	89	24	29210	12.5	88	20	29210	10.3	88
60.59	36		29210	18.9	89	28	29210	14.6	89	23	29210	12.1	88	
55.79	39		28940	20	89	30	29210	15.8	89	25	29210	13.1	88	
49.87	44		28050	22	90	34	29210	17.7	89	28	29210	14.6	89	
44.89	49		26990	23	90	38	29210	19.6	89	31	29210	16.2	89	
40.65	54		26110	25	90	42	28590	21	90	34	29210	17.8	89	
36.05	61		24870	27	90	47	27520	23	90	39	29210	20	89	
32.60	67		23900	28	90	52	26370	24	90	43	28320	21	90	
27.63	80		21150	30	90	62	24870	27	90	51	26640	24	90	
24.13	91		18230	30	90	70	23630	30	90	58	25400	25	90	
26.39	35/6		83	22570	32	93	64	23010	25	93	53	23010	21	92
23.59			93	21680	35	93	72	23010	28	93	59	23010	23	93
21.23			104	21060	38	93	80	22740	31	93	66	23010	25	93
19.23			114	20180	39	93	88	22130	34	93	73	23010	28	93
17.05		129	19200	42	93	100	21240	36	93	82	22740	32	93	
15.42		143	18050	44	93	110	20360	38	93	91	21860	34	93	
13.07		168	15220	43	93	130	19200	43	93	107	20620	38	93	
11.41		193	13100	43	93	149	17700	44	93	123	19560	40	93	
9.55		230	10620	42	93	178	14780	44	93	147	18050	44	94	
8.26		266	8670	40	93	206	12740	44	93	169	15660	46	94	

All values reflect mechanical limits. Shaded area indicates additional thermal limitations where $P_{emax} = 30$ HP for continuous use.

1100 - 700 rpm

02 968 097

S97													
i [ratio]	Worm ratio/ # starts	$n_e = 1100 \text{ rpm}$				$n_e = 900 \text{ rpm}$				$n_e = 700 \text{ rpm}$			
		n_a [rpm]	T_{amax} [lb-in]	P_e [HP]	η [%]	n_a [rpm]	T_{amax} [lb-in]	P_e [HP]	η [%]	n_a [rpm]	T_{amax} [lb-in]	P_e [HP]	η [%]
286.40	40/1	3.8	37170	3.2	70	3.1	37170	2.7	69	2.4	37170	2.1	68
262.22		4.2	37170	3.5	71	3.4	37170	3.0	70	2.7	37170	2.3	68
231.67		4.7	37170	3.9	72	3.9	37170	3.2	70	3.0	37170	2.5	69
196.52		5.6	36820	4.6	73	4.6	37170	3.8	71	3.6	37170	3.0	70
180.95		6.1	36460	4.8	73	5.0	37170	4.0	72	3.9	37170	3.2	70
161.74		6.8	35670	5.2	74	5.6	36820	4.4	73	4.3	37170	3.6	71
145.60		7.6	34960	5.6	74	6.2	36110	4.8	73	4.8	37170	3.9	72
131.85		8.3	34340	6.0	75	6.8	35670	5.2	74	5.3	37170	4.3	72
116.92		9.4	33280	6.6	75	7.7	34600	5.6	74	6.0	36460	4.7	73
105.71		10	32300	7.1	76	8.5	33980	6.2	75	6.6	35670	5.1	74
89.60	37/3	12	30980	7.9	76	10	32660	6.8	76	7.8	34600	5.8	75
78.26		14	29820	8.7	77	12	31680	7.6	76	8.9	33630	6.3	75
65.45		17	28050	9.7	77	14	30090	8.6	77	11	32300	7.2	76
80.85		14	28590	7.1	87	11	28320	5.8	86	8.7	28050	4.6	85
71.43		15	31860	9.0	87	13	31860	7.4	87	9.8	31860	5.8	86
60.59		18	31860	10.5	88	15	31860	8.6	87	12	31860	6.7	86
55.79		20	31860	11.4	88	16	31860	9.4	87	13	31860	7.4	87
49.87		22	31860	12.6	88	18	31860	10.5	88	14	31860	8.2	87
44.89		25	31860	13.9	88	20	31860	11.5	88	16	31860	9.0	87
40.65		27	31860	15.4	89	22	31860	12.7	88	17	31860	9.9	88
36.05	31	31240	17.0	89	25	31860	14.2	89	19	31860	11.1	88	
32.60	34	30270	18.1	89	28	31860	15.7	89	21	31860	12.3	88	
27.63	40	28850	20	90	33	30620	17.7	89	25	31860	14.5	89	
24.13	46	27700	22	90	37	29380	19.4	89	29	31510	16.4	89	
26.39	42	23450	16.9	92	34	23190	13.7	92	27	23190	10.7	91	
23.59	47	23450	18.8	92	38	23450	15.4	92	30	23190	11.9	91	
21.23	52	23450	21	92	42	23450	17.2	92	33	23190	13.3	92	
19.23	57	23450	23	93	47	23450	18.9	92	36	23190	14.6	92	
17.05	35/6	65	23630	25	93	53	23450	21	92	41	23450	16.6	92
15.42		71	23630	28	93	58	23450	23	93	45	23450	18.4	92
13.07		84	22480	32	93	69	23630	28	93	54	23450	22	92
11.41		96	21420	35	93	79	22920	31	93	61	23450	25	93
9.55		115	20180	39	93	94	21590	35	93	73	23450	30	93
8.26	133	18940	43	94	109	20530	38	93	85	22480	32	93	

All values reflect mechanical limits. Shaded area indicates additional thermal limitations where $P_{emax} = 30 \text{ HP}$ for continuous use.

500 - 10 rpm

02 968 097

S97														
i [ratio]	Worm ratio/ # starts	n_e = 500 rpm				n_e = 250 rpm				n_e = 10 rpm				
		n _a [rpm]	T _{amax} [lb-in]	P _e [HP]	η [%]	n _a [rpm]	T _{amax} [lb-in]	P _e [HP]	η [%]	n _a [rpm]	T _{amax} [lb-in]	P _e [HP]	η [%]	
286.40	40/1	1.7	37170	1.6	65	0.87	37170	0.83	62	0.03	37170	0.00	60	
262.22		1.9	37170	1.7	66	0.95	37170	0.91	62	0.04	37170	0.00	60	
231.67		2.2	37170	1.9	67	1.1	37170	1.0	63	0.04	37170	0.00	60	
196.52		2.5	37170	2.1	68	1.3	37170	1.2	64	0.05	37170	0.00	60	
180.95		2.8	37170	2.4	68	1.4	37170	1.3	64	0.06	37170	0.00	60	
161.74		3.1	37170	2.7	69	1.5	37170	1.5	65	0.06	37170	0.00	60	
145.60		3.4	37170	3.0	70	1.7	37170	1.6	65	0.07	37170	0.07	60	
131.85		3.8	37170	3.2	70	1.9	37170	1.7	66	0.08	37170	0.08	60	
116.92		4.3	37170	3.5	71	2.1	37170	1.9	67	0.09	37170	0.08	60	
105.71		4.7	37170	3.9	72	2.4	37170	2.0	67	0.09	37170	0.09	60	
89.60		5.6	36820	4.4	73	2.8	37170	2.4	69	0.11	37170	0.11	60	
78.26		6.4	36110	5.0	74	3.2	37170	2.7	69	0.13	37170	0.12	60	
65.45		7.6	34600	5.6	75	3.8	37170	3.2	70	0.15	37170	0.15	60	
80.85		37/3	6.2	27520	3.2	84	3.1	26640	1.6	82	0.12	26640	0.00	80
71.43			7.0	37170	4.8	85	3.5	36820	2.5	82	0.14	36820	0.11	81
60.59			8.3	37170	5.8	85	4.1	36110	2.8	83	0.17	36110	0.12	81
55.79	9.0		37170	6.2	86	4.5	37170	3.2	83	0.18	37170	0.13	81	
49.87	10		37170	6.8	86	5.0	37170	3.5	83	0.20	37170	0.15	81	
44.89	11		36820	7.5	86	5.6	37170	3.9	84	0.22	37170	0.16	81	
40.65	12		36460	8.2	87	6.2	37170	4.3	84	0.25	37170	0.17	81	
36.05	14		36110	9.1	87	6.9	37170	4.8	85	0.28	37170	0.20	81	
32.60	15		35310	9.8	87	7.7	37170	5.4	85	0.31	37170	0.23	81	
27.63	18		34600	11.3	88	9.0	37170	6.3	86	0.36	37170	0.27	81	
24.13	21		33630	12.5	88	10	37170	7.1	86	0.41	37170	0.31	81	
26.39	35/6		19	22920	7.6	90	9.5	22480	3.8	89	0.38	22480	0.16	87
23.59			21	22920	8.4	91	11	22480	4.3	89	0.42	22480	0.17	87
21.23			24	22920	9.4	91	12	22740	4.8	89	0.47	22740	0.20	87
19.23			26	23190	10.5	91	13	22740	5.2	89	0.52	22740	0.21	87
17.05			29	23190	11.8	91	15	22740	5.9	90	0.59	22740	0.24	87
15.42		32	23190	13.0	92	16	22740	6.4	90	0.65	22740	0.27	87	
13.07		38	23450	15.6	92	19	22920	7.6	90	0.77	22920	0.32	87	
11.41		44	23450	17.7	92	22	22920	8.9	91	0.88	22920	0.36	87	
9.55		52	23450	21	92	26	23190	10.6	91	1.0	23190	0.44	87	
8.26		61	23450	24	93	30	23190	12.2	91	1.2	23190	0.51	87	

11

11.11 Output shaft sizes

11.11.1 Solid shaft - Inch

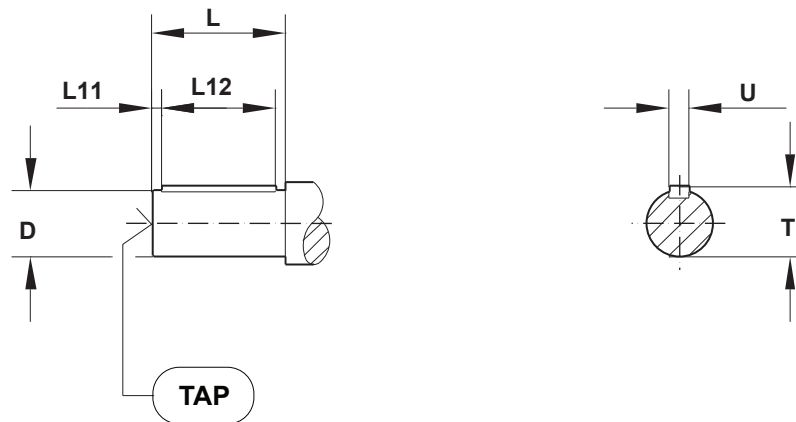

All dimensions in inches							
Model	D	T	U	L ¹⁾	L11	L12	TAP
S..37	0.75	0.83	3/16	1.57	0.25	1-1/16	1/4 - 20 x 0.63
S..47	1	1.11	1/4	1.97	0.32	1-5/16	3/8 - 16 x 0.87
S..57	1.25	1.36	1/4	2.36	0.26	1-11/16	1/2 - 13 x 1.12
S..67	1.375	1.51	5/16	2.76	0.43	1-13/16	1/2 - 13 x 1.12
S..77	1.75	1.92	3/8	3.54	0.38	2-3/4	5/8 - 11 x 1.38
S..87	2.375	2.65	5/8	4.72	0.51	3-5/8	3/4 - 10 x 1.61
S..97	2.875	3.2	3/4	5.51	0.67	4-1/8	3/4 - 10 x 1.61

1) Longer shafts to match older designs (ie: SF..60, SF..62) are available for flanged units.

11.11.2 Solid shaft - Metric

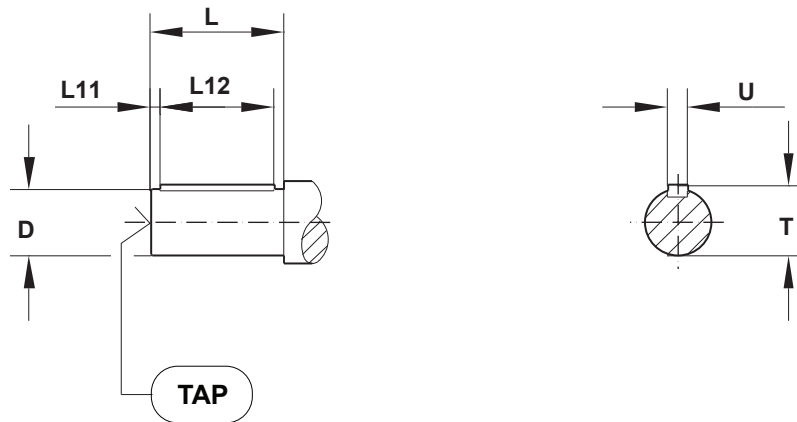

All dimensions in mm							
Model	D	T	U	L ¹⁾	L11	L12	TAP
S..37	20	22.5	6	40	4	32	M6 x 16
S..47	25	28	8	50	5	40	M10 x 22
S..57	30	33	8	60	3.5	50	M10 x 22
S..67	35	38	10	70	7	56	M12 x 28
S..77	45	48.5	14	90	5	80	M16 x 36
S..87	60	64	18	120	5	110	M20 x 42
S..97	70	74.5	20	140	7.5	125	M20 x 42

1) Longer shafts to match older designs (ie: SF..60, SF..62) are available for flanged units.

11.11.3 Hollow shafts - Inch

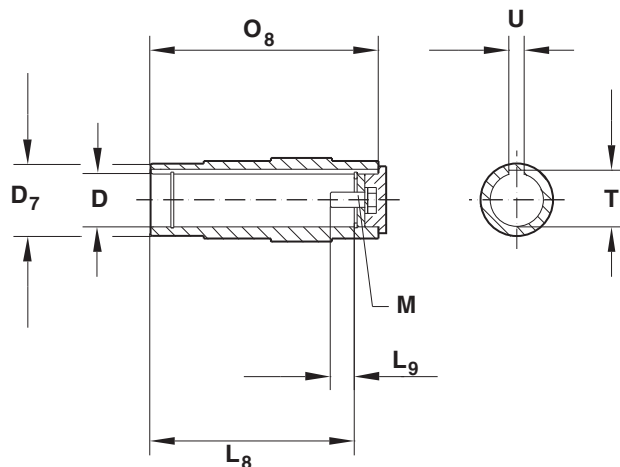

All dimensions in inches								
Model	D	D ₇	O ₈	T	U	L ₈	L ₉	M
SA..37	0.75	1.38	4.72	0.84	3/16	4.09	0.37	1/4 - 20 x 5/8
SA..47	1.25	1.77	4.72	1.37	1/4	4.13	0.67	7/16 - 14 x 1
SA..57	1.1875	1.97	5.91	1.30	1/4	5.20	0.67	3/8 - 16 x 1
	1.25	1.97	5.91	1.37	1/4	5.20	0.67	7/16 - 14 x 1
	1.375	1.97	5.91	1.52	5/16	5.20	0.65	1/2 - 13 x 1
	1.4375	1.97	5.91	1.61	3/8	5.20	0.65	5/8 - 11 x 1-3/4
SA..67	1.25	2.56	6.61	1.37	1/4	5.67	0.67	7/16 - 14 x 1
	1.50	2.56	6.61	1.67	3/8	5.67	1.36	5/8 - 11 x 1-3/4
SA..77	2.00	3.15	8.27	2.22	1/2	7.20	1.16	5/8 - 11 x 1-3/4
SA..87	2.375	3.74	9.84	2.65	5/8	8.66	1.37	3/4 - 10 x 2
SA..97	2.75	4.72	11.42	3.03	5/8	10.23	1.24	3/4 - 10 x 2

11.11.4 Hollow shaft - Metric

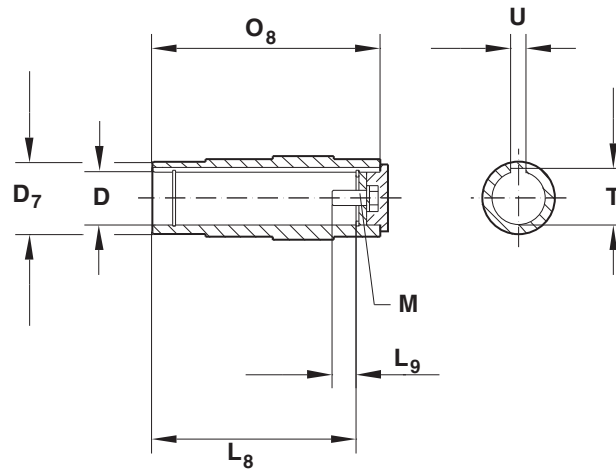

11

All dimensions in mm								
Model	D	D ₇	O ₈	T	U	L ₈	L ₉	M
SA..37	20	35	120	22.8	6	104	8	M6 x 16
SA..47	25	45	120	28.3	8	105	17	M10 x 25
	30	45	120	33.3	8	105	17	M10 x 25
SA..57	30	50	150	33.3	8	132	17	M10 x 25
	35	50	150	38.3	10	132	22	M12 x 30
SA..67	40	65	168	43.3	12	144	29	M16 x 40
	45	65	168	48.3	14	144	29	M16 x 40
SA..77	50	80	210	53.8	14	183	32	M16 x 45
	60	80	210	64.4	18	180	37	M20 x 50
SA..87	60	95	250	64.4	18	220	36	M20 x 50
	70	95	250	74.9	20	220	34	M20 x 50
SA..97	70	120	290	74.9	20	260	34	M20 x 50
	90	120	290	95.4	25	255	41	M24 x 60

11.11.5 TorqLOC keyless hollow shaft

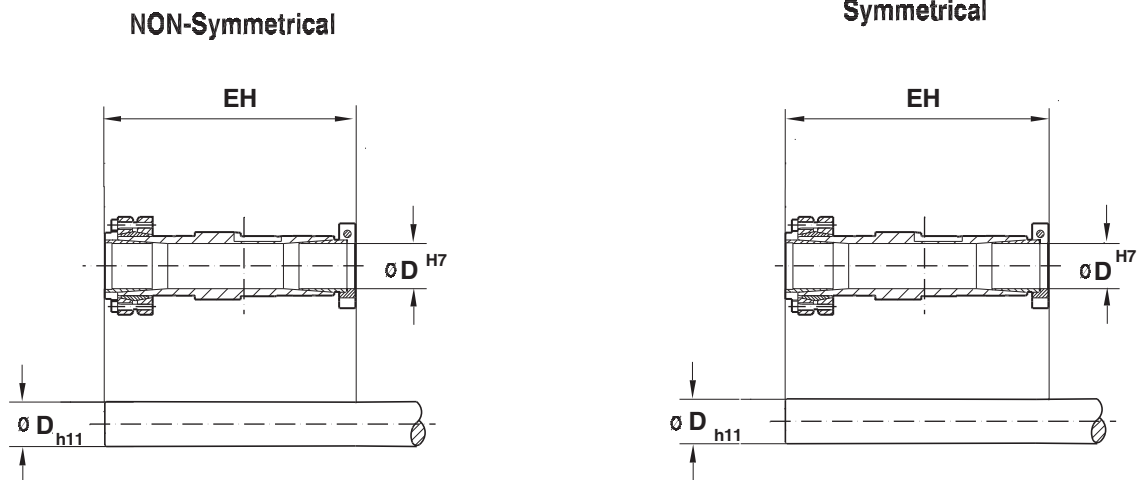

Metric and inch bores are available as shown below.

Model	D (in)					D (mm)			EH (inches)	
	Inch Bores					Metric Bores			NON-Symmetrical	Symmetrical
ST37	0.625	0.6875	0.75	-	-	16	19	20	6.54	7.33
ST47	1.00	1.1875	1.25	-	-	25	30	-	6.69	7.63
ST57	1.1875	1.25	1.375	1.4375	-	30	35	-	8.15	9.13
ST67	1.375	1.4375	1.50	1.625	1.688	35	38	40	9.17	10.43
ST77	1.625	1.75	1.9375	2.00	-	50	-	-	11.61	13.34
ST87	1.9375	2.00	2.375	2.4375	-	51	62	65	13.50	15.47
ST97	2.4375	2.75	2.9375	-	-	62	70	75	15.00	16.97

12 W - Spiroplan®

12.1 W.. AM

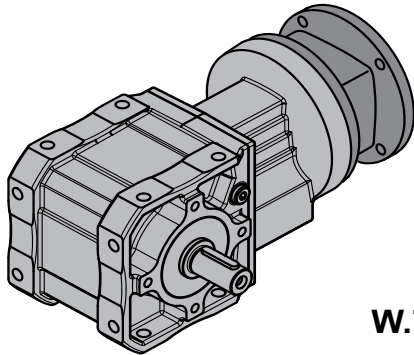

W.7 AM..

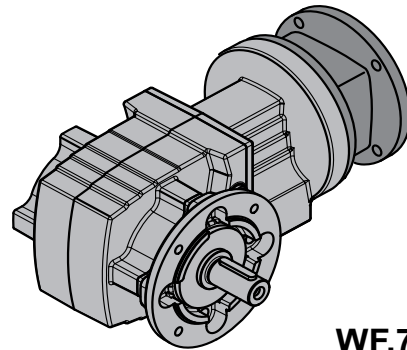

WF.7 AM..

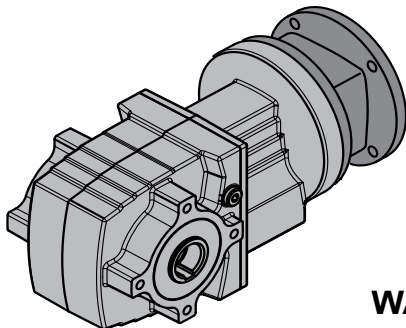

WA.7 AM..

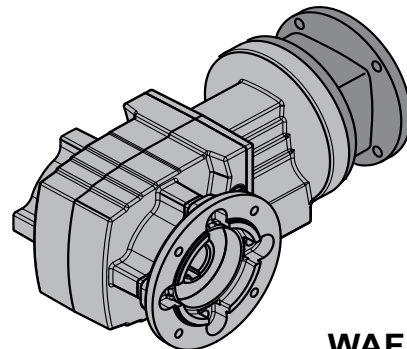

WAF.7 AM..

12

68395AXX

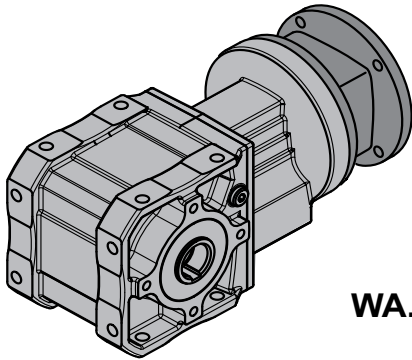

WA.7B AM..

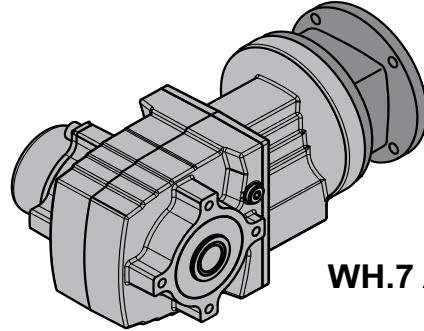

WH.7 AM..

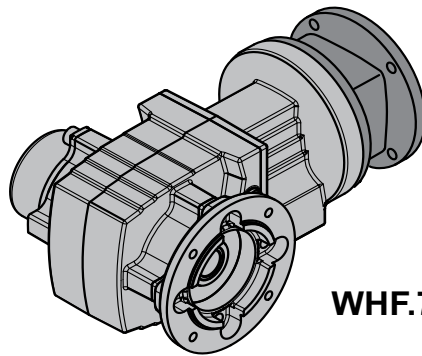

WHF.7 AM..

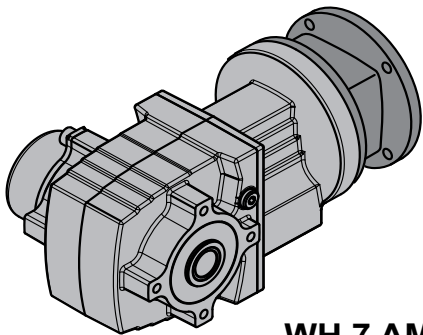

WH.7 AM..

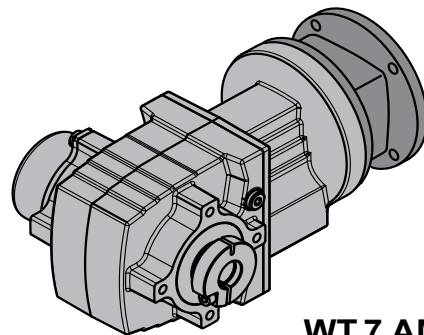

WT.7 AM..

68394AXX

12.1.1 W37

W37, n _e = 1700 rpm						970 lb-in		
Stages	i [ratio]	n _a [rpm]	T _{a max} [lb-in]	F _{Ra} [lb]	Φ (i/R) [']	56	AM 143	145
W37  2	3.20	531	615	460	-			
	3.93	433	615	500	-			
	5.11	333	615	560	-			
	5.77	295	615	585	-			
	6.97	244	615	630	-			
	8.55	199	615	680	-			
	9.92	171	615	720	-			
	10.67	159	795	590	-			
	11.65	146	615	770	-			
	12.70	134	615	795	-			
	13.89	122	795	670	-			
	15.67	108	795	705	-			
	18.94	90	795	770	-			
	21.33	80	970	695	-			
	23.25	73	795	810	-			
	26.96	63	795	810	-			
	27.78	61	970	745	-			
	31.33	54	970	745	-			
	31.67	54	795	810	-			
	34.52	49	795	810	-			
37.88	45	970	745	-				
46.49	37	970	745	-				
53.92	32	970	745	-				
63.33	27	970	745	-				
69.05	25	970	745	-				

Weight [lbs]		Stages	56	AM 143	145
W37	NEMA	2	20	24	24
			71	80	90
	IEC	2	18	24	24
WA37: +0 lbs / WAF37: +0 lbs / WF37: +0 lbs					

12.1.2 W47

W47, n _e = 1700 rpm						1590 lb-in				
Stages	i [ratio]	n _a [rpm]	T _{a max} [lb-in]	F _{Ra} [lb]	Φ _(/R) [']	56	143	AM 145	182	184
W47 	3.27	520	970	550	-					
	3.89	437	970	595	-					
	4.40	386	970	625	-					
	5.23	325	970	670	-					
	5.58	305	970	690	-					
	6.53	260	970	735	-					
	7.32	232	970	770	-					
	8.61	197	970	820	-					
	9.96	171	970	870	-					
	10.66	159	970	900	-					
	11.32	150	1410	705	-					
	12.30	138	970	950	-					
	13.44	126	1410	770	-					
	14.35	118	1410	795	-					
	16.80	101	1410	860	-					
	18.82	90	1410	900	-					
	22.15	77	1410	980	-					
	25.07	68	1590	900	-					
	25.62	66	1410	1040	-					
	26.76	64	1590	930	-					
	27.41	62	1410	1080	-					
	31.33	54	1590	1010	-					
	31.62	54	1410	1150	-					
	35.09	48	1590	1070	-					
	41.30	41	1590	1160	-					
	47.78	36	1590	1240	-					
51.12	33	1590	1280	-						
58.98	29	1590	1370	-						
68.93	25	1590	1440	-						
74.98	23	1590	1440	-						

Weight [lbs]		Stages	56	143	AM 145	182	184
W47	NEMA	2	33	37	37	45	45
			71	80	90	100	112
	IEC	2	32	37	37	48	48

WA47: +1 lb / WAF47: -3 lbs / WF47: -2 lbs

12.2 W.. AD

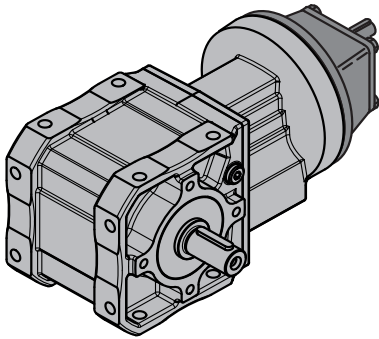

W.7 AD..

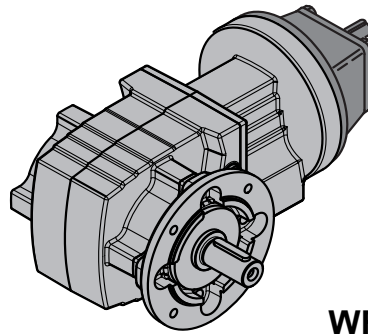

WF.7 AD..

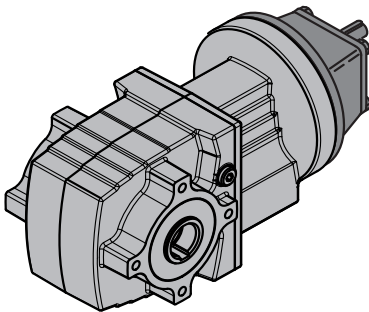

WA.7 AD..

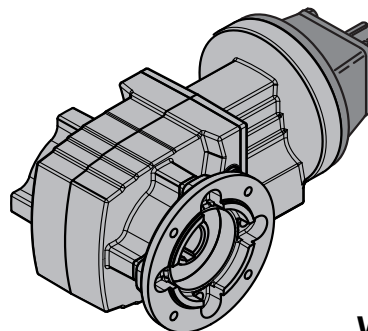

WAF.7 AD..

12

68396AXX

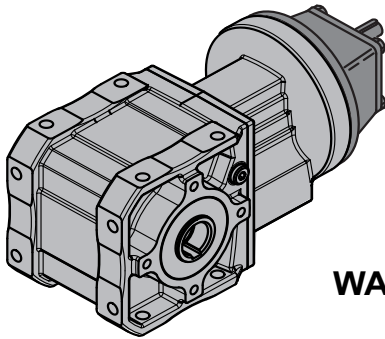

WA.7B AD..

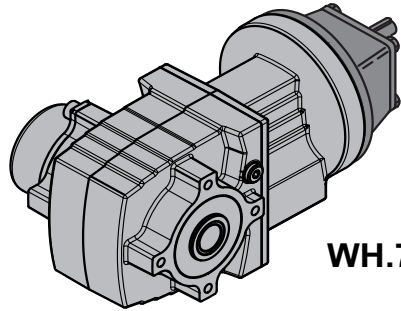

WH.7 AD..

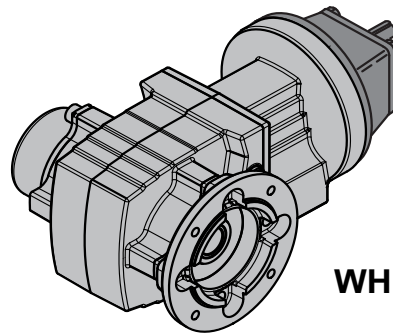

WHF.7 AD..

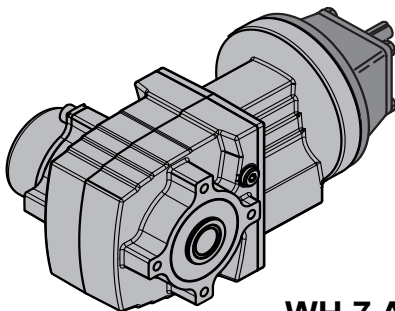

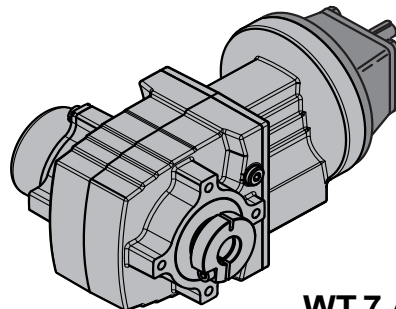

WH.7 AD..





WT.7 AD..

68397AXX

12.2.1 W37

W37 AD.. , n _e = 1700 rpm										970 lb-in		
i [ratio]	n _a [rpm]	T _a max [lb-in]	P _e [HP]	F _{Ra} ¹⁾ [lb]	F _{Re} [lb]	Stages		φ _(/R) [']				
						Lg	Sm					
13.89	122	800	1.9	670	10	2	-	-	-	-	W37	AD1
15.67	108	800	1.7	710	20	2	-	-	-	-		
18.94	90	800	1.4	770	30	2	-	-	-	-		
21.33	80	970	1.7	700	50	2	-	-	-	-		
23.25	73	800	1.2	810	40	2	-	-	-	-		
26.96	63	800	1.0	810	50	2	-	-	-	-		
27.78	61	970	1.3	750	70	2	-	-	-	-		
31.33	54	970	1.2	750	70	2	-	-	-	-		
31.67	54	800	0.87	810	50	2	-	-	-	-		
34.52	49	800	0.80	810	50	2	-	-	-	-		
37.88	45	970	1.0	750	80	2	-	-	-	-		
46.49	37	970	0.85	750	90	2	-	-	-	-		
53.92	32	970	0.74	750	90	2	-	-	-	-		
3.20	531	620	5.8	460	240	2	-	-	-	-	W37	AD2
3.93	433	620	4.7	500	260	2	-	-	-	-		
5.11	333	620	3.7	560	270	2	-	-	-	-		
5.77	295	620	3.2	580	280	2	-	-	-	-		
6.97	244	620	2.7	630	290	2	-	-	-	-		
8.55	199	620	2.2	680	290	2	-	-	-	-		
9.92	171	620	1.9	720	300	2	-	-	-	-		
10.67	159	800	2.4	590	330	2	-	-	-	-		
11.65	146	620	1.6	770	110	2	-	-	-	-		
12.70	134	620	1.5	790	120	2	-	-	-	-		
13.89	122	800	1.9	670	340	2	-	-	-	-		
15.67	108	800	1.7	710	340	2	-	-	-	-		
18.94	90	800	1.4	770	340	2	-	-	-	-		
21.33	80	970	1.7	700	350	2	-	-	-	-		
23.25	73	800	1.2	810	350	2	-	-	-	-		
26.96	63	800	1.0	810	350	2	-	-	-	-		
27.78	61	970	1.3	750	360	2	-	-	-	-		
31.33	54	970	1.2	750	360	2	-	-	-	-		
31.67	54	800	0.88	810	300	2	-	-	-	-		
34.52	49	800	0.82	810	300	2	-	-	-	-		
37.88	45	970	1.0	750	360	2	-	-	-	-		
46.49	37	970	0.86	750	360	2	-	-	-	-		
53.92	32	970	0.76	750	360	2	-	-	-	-		
63.33	27	970	0.66	750	350	2	-	-	-	-		
69.05	25	970	0.61	750	350	2	-	-	-	-		
Weight [lbs]		Stages			AD1		AD2					
		Large	Small									
W37		2	-			17		20				
WA37: +0 lbs / WAF37: +0 lbs / WF37: +0 lbs												

12.2.2 W47

W47 AD.. , n _e = 1700 rpm										1500 lb-in		
i [ratio]	n _a [rpm]	T _{a max} [lb-in]	P _e [HP]	F _{Ra} ¹⁾ [lb]	F _{Re} [lb]	Stages		φ (/R) [']				
						Lg	Sm					
3.27	520	970	8.5	550	200	2	-	-	-			
3.89	437	970	7.2	590	210	2	-	-	-			
4.40	386	970	6.4	630	230	2	-	-	-			
5.23	325	970	5.4	670	240	2	-	-	-			
5.58	305	970	5.1	690	240	2	-	-	-			
6.53	260	970	4.3	740	250	2	-	-	-			
7.32	232	970	3.9	770	260	2	-	-	-			
8.61	197	970	3.3	820	270	2	-	-	-			
9.96	171	970	2.9	870	270	2	-	-	-			
10.66	159	970	2.7	900	270	2	-	-	-			
11.32	150	1420	3.9	710	290	2	-	-	-			
12.30	138	970	2.3	950	280	2	-	-	-			
13.44	126	1420	3.3	770	300	2	-	-	-			
14.35	118	1420	3.1	790	310	2	-	-	-			
16.80	101	1420	2.7	860	310	2	-	-	-		W47	AD2
18.82	90	1420	2.4	910	310	2	-	-	-			
22.15	77	1420	2.1	980	320	2	-	-	-			
25.07	68	1590	2.2	900	340	2	-	-	-			
25.62	66	1420	1.8	1040	320	2	-	-	-			
26.76	64	1590	2.1	930	340	2	-	-	-			
27.41	62	1420	1.7	1080	320	2	-	-	-			
31.33	54	1590	1.8	1010	340	2	-	-	-			
31.62	54	1420	1.5	1150	320	2	-	-	-			
35.09	48	1590	1.7	1070	340	2	-	-	-			
41.30	41	1590	1.4	1160	340	2	-	-	-			
47.78	36	1590	1.3	1240	350	2	-	-	-			
51.12	33	1590	1.2	1280	350	2	-	-	-			
58.98	29	1590	1.0	1370	350	2	-	-	-			
68.93	25	1590	0.91	1440	290	2	-	-	-			
74.98	23	1590	0.85	1440	290	2	-	-	-			
3.27	520	970	8.6	550	410	2	-	-	-			
3.89	437	970	7.2	590	430	2	-	-	-			
4.40	386	970	6.4	630	440	2	-	-	-			
5.23	325	970	5.4	670	460	2	-	-	-			
5.58	305	970	5.1	690	460	2	-	-	-			
6.53	260	970	4.4	740	470	2	-	-	-			
7.32	232	970	3.9	770	470	2	-	-	-			
8.61	197	970	3.3	820	480	2	-	-	-			
11.32	150	1420	4.0	710	510	2	-	-	-			
13.44	126	1420	3.4	770	520	2	-	-	-		W47	AD3
14.35	118	1420	3.2	790	520	2	-	-	-			
16.80	101	1420	2.7	860	520	2	-	-	-			
18.82	90	1420	2.5	910	530	2	-	-	-			
22.15	77	1420	2.1	980	530	2	-	-	-			
25.07	68	1590	2.3	900	550	2	-	-	-			
26.76	64	1590	2.2	930	550	2	-	-	-			
31.33	54	1590	1.9	1010	550	2	-	-	-			
35.09	48	1590	1.7	1070	550	2	-	-	-			
41.30	41	1590	1.5	1160	560	2	-	-	-			

Weight [lbs]	Stages		AD2	AD3
	Large	Small		
W47	2	-	33	40

WA47: +1 lb / WAF47: -3 lbs / WF47: -2 lbs

WHF37..

20 013 00 11

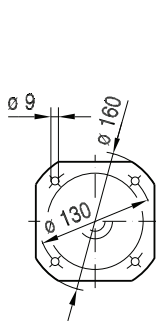
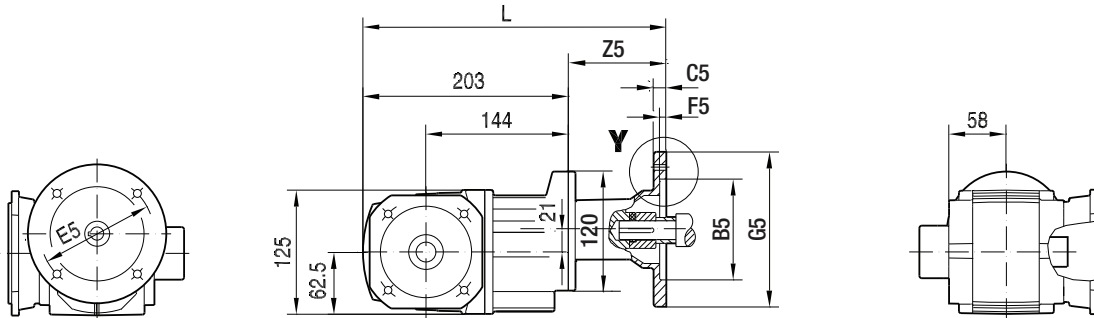

Ø 160

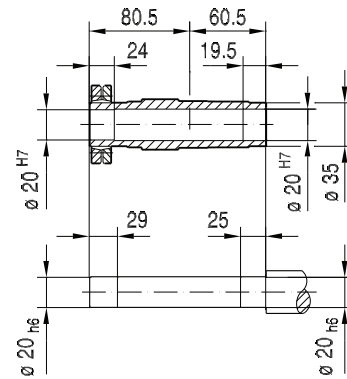
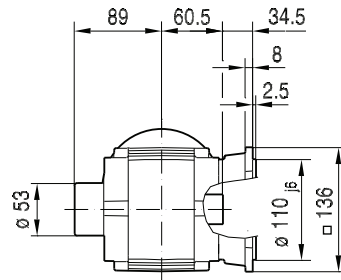

12

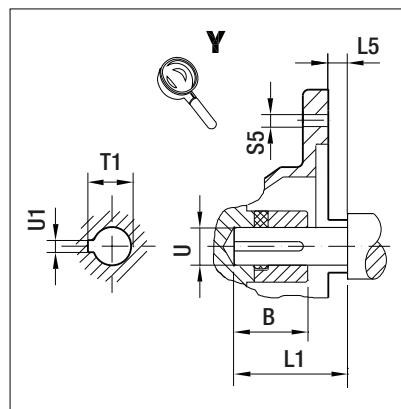

(→ 132)	B	B5	C5	E5	F5	G5	L	L1	L5	S5	T1	U	U1	Z5
AM56	1.23 in	4.50 in	11	5.875 in	4.5	170	297	1.88 in	-0.18 in	10.5	0.71 in	0.625 in	0.188 in	93.5
AM143	1.68 in	4.50 in	12	5.875 in	4.5	170	320	2.25 in	0.13 in	10.5	0.98 in	0.875 in	0.188 in	117
AM145	1.68 in	4.50 in	12	5.875 in	4.5	170	320	2.25 in	0.13 in	10.5	0.98 in	0.875 in	0.188 in	117

Dimensions in mm unless otherwise noted.

WA37..

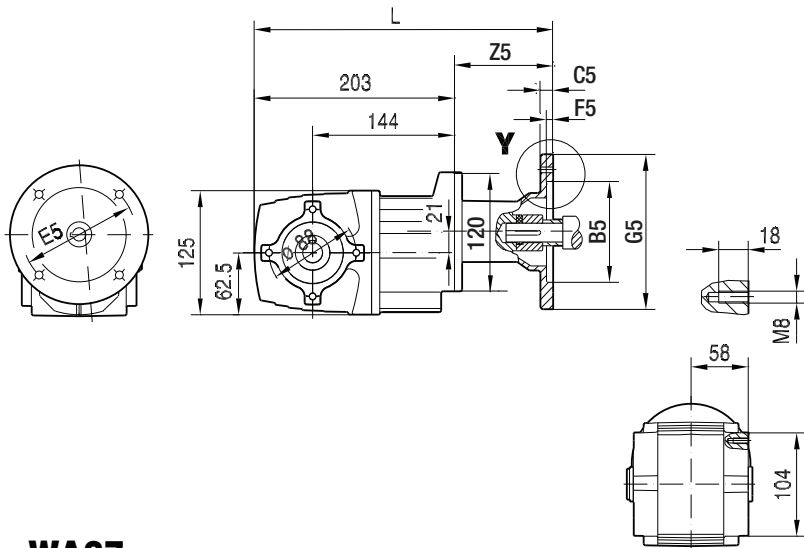

20 014 00 11

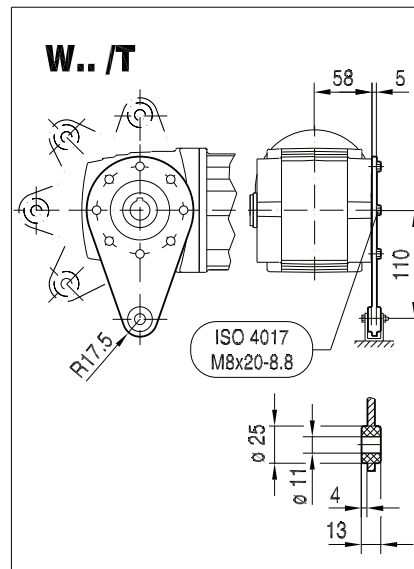

WA37..

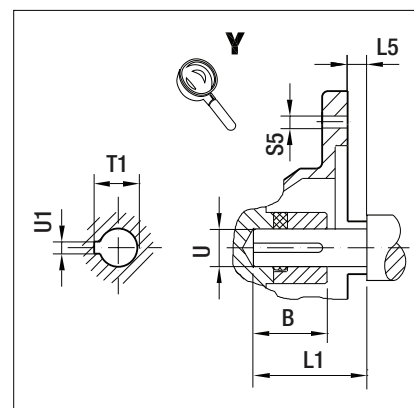
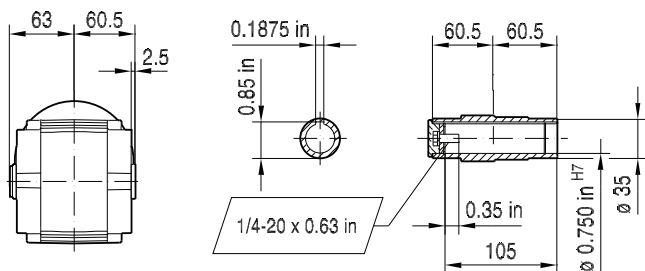

WH37..

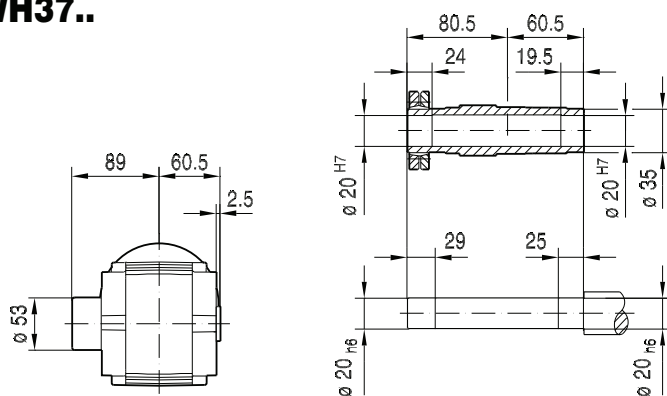

(→ 132)	B	B5	C5	E5	F5	G5	L	L1	L5	S5	T1	U	U1	Z5
AM56	1.23 in	4.50 in	11	5.875 in	4.5	170	297	1.88 in	-0.18 in	10.5	0.71 in	0.625 in	0.188 in	93.5
AM143	1.68 in	4.50 in	12	5.875 in	4.5	170	320	2.25 in	0.13 in	10.5	0.98 in	0.875 in	0.188 in	117
AM145	1.68 in	4.50 in	12	5.875 in	4.5	170	320	2.25 in	0.13 in	10.5	0.98 in	0.875 in	0.188 in	117

Dimensions in mm unless otherwise noted. For all available output shaft diameters, see page 710.

WT37..

20 015 00 11

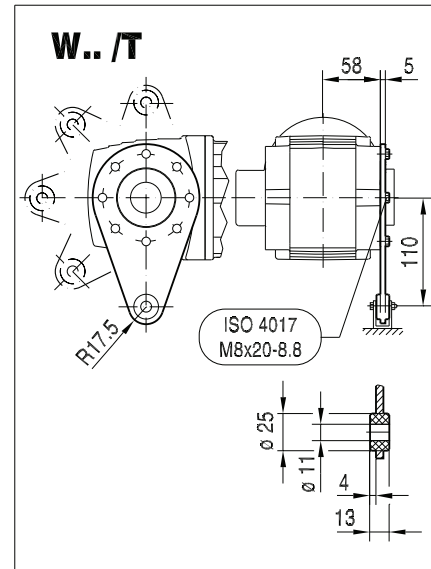
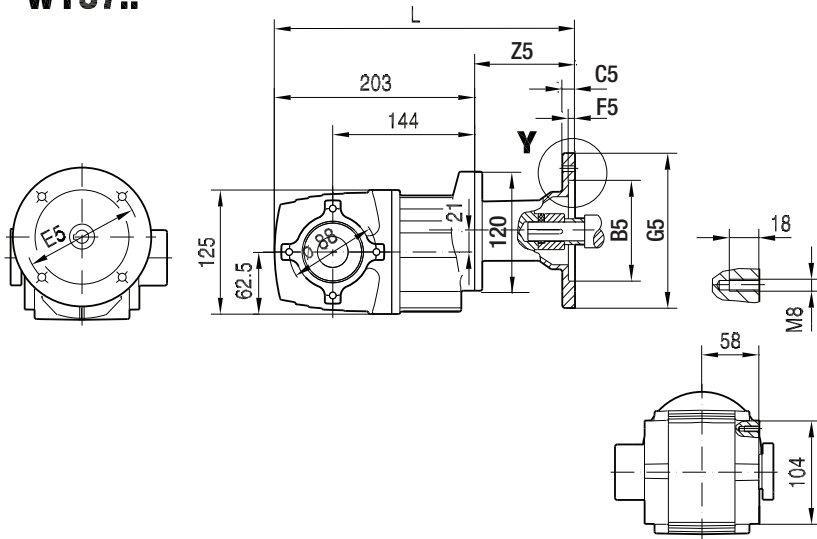

NON-Symmetrical

Symmetrical

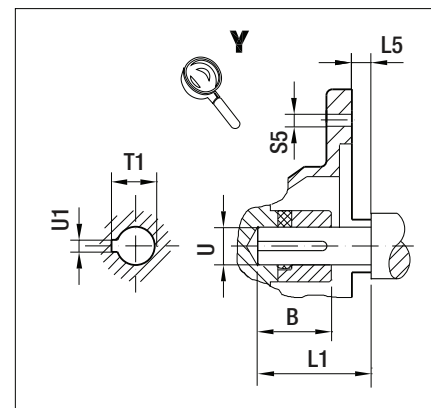
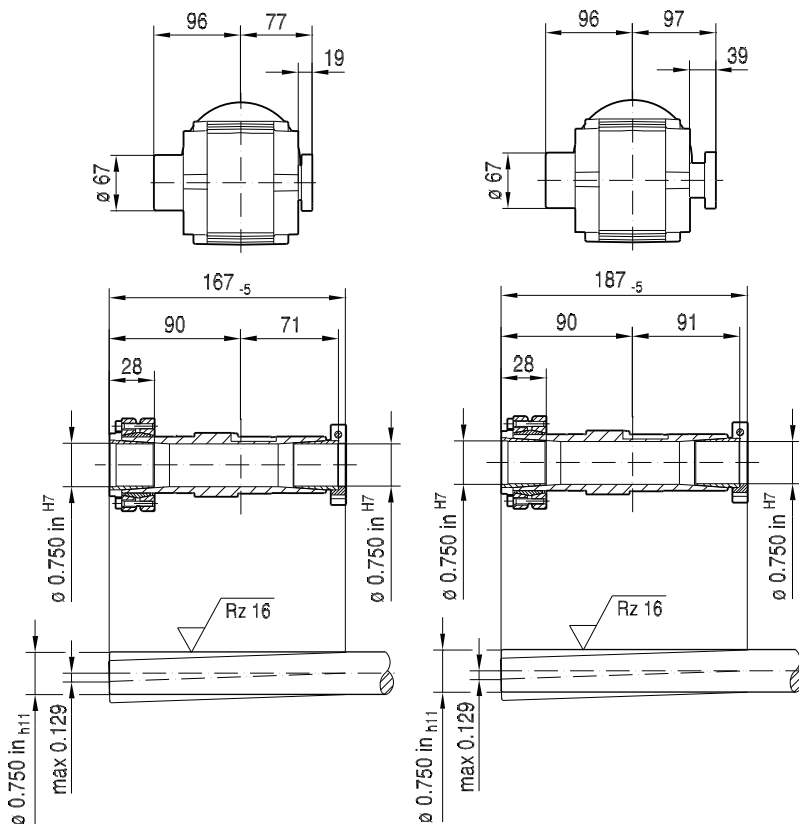

12

(→ 132)	B	B5	C5	E5	F5	G5	L	L1	L5	S5	T1	U	U1	Z5
AM56	1.23 in	4.50 in	11	5.875 in	4.5	170	297	1.88 in	-0.18 in	10.5	0.71 in	0.625 in	0.188 in	93.5
AM143	1.68 in	4.50 in	12	5.875 in	4.5	170	320	2.25 in	0.13 in	10.5	0.98 in	0.875 in	0.188 in	117
AM145	1.68 in	4.50 in	12	5.875 in	4.5	170	320	2.25 in	0.13 in	10.5	0.98 in	0.875 in	0.188 in	117

Dimensions in mm unless otherwise noted. For all available output shaft diameters, see page 712.

20 016 00 11

W47..

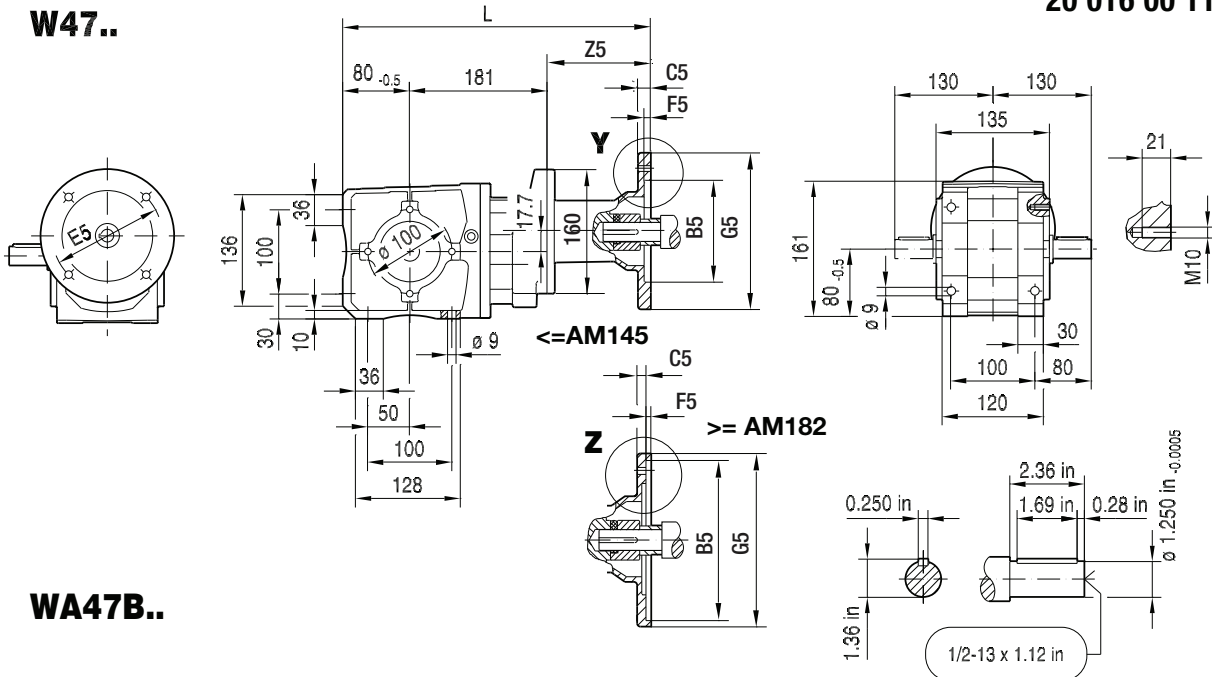

WA47B..

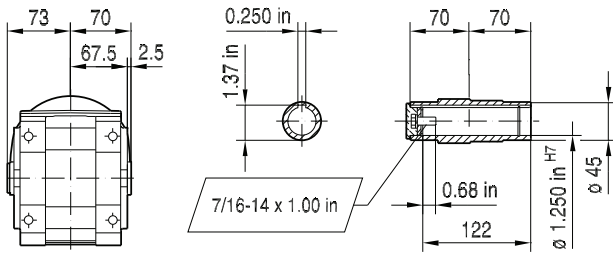

WH47B..

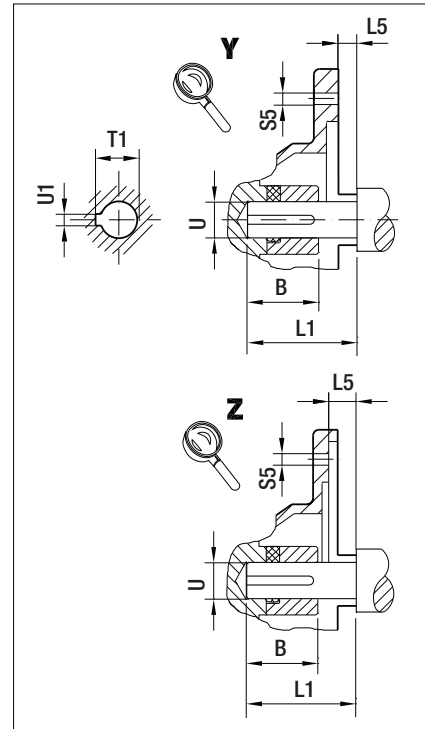
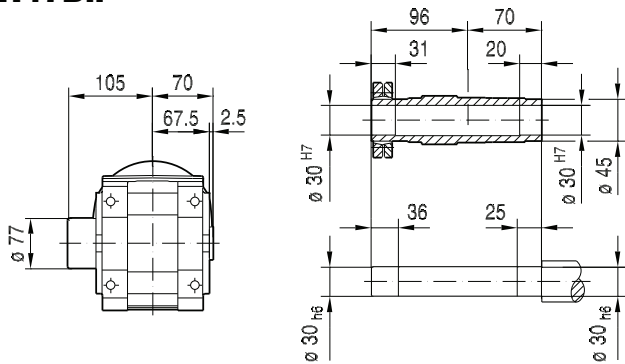

(→ 132)	B	B5	C5	E5	F5	G5	L	L1	L5	S5	T1	U	U1	Z5
AM56	1.23 in	4.50 in	11	5.875 in	4.5	170	348	1.88 in	-0.18 in	10.5	0.71 in	0.625 in	0.188 in	87
AM143	1.68 in	4.50 in	12	5.875 in	4.5	170	372	2.25 in	0.13 in	10.5	0.98 in	0.875 in	0.188 in	110.5
AM145	1.68 in	4.50 in	12	5.875 in	4.5	170	372	2.25 in	0.13 in	10.5	0.98 in	0.875 in	0.188 in	110.5
AM182	2.10 in	8.50 in	10	7.25 in	5	228	409	2.75 in	0.13 in	15	1.24 in	1.125 in	0.250 in	147.5
AM184	2.10 in	8.50 in	10	7.25 in	5	228	409	2.75 in	0.13 in	15	1.24 in	1.125 in	0.250 in	147.5

Note: Dimensions in mm unless otherwise noted. For all available output shaft diameters, see page 708.

WA47..

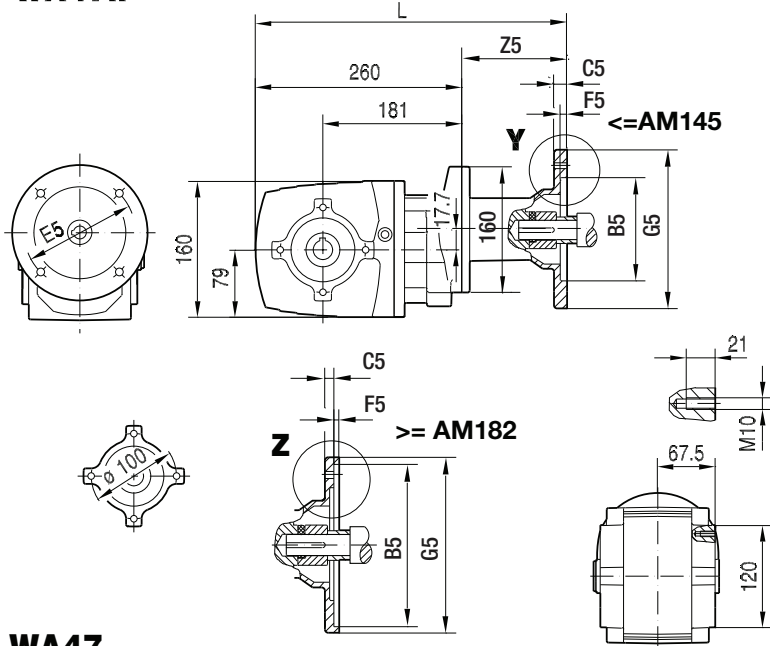

20 018 00 11

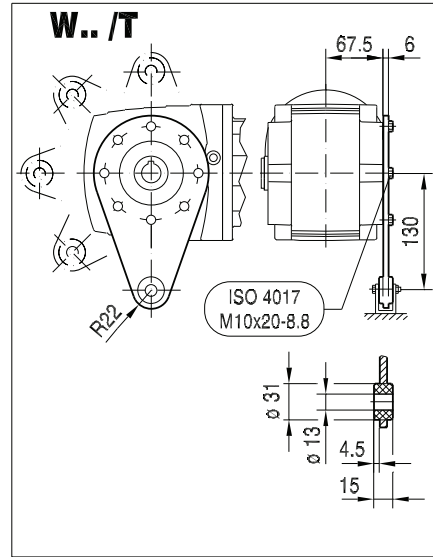

WA47..

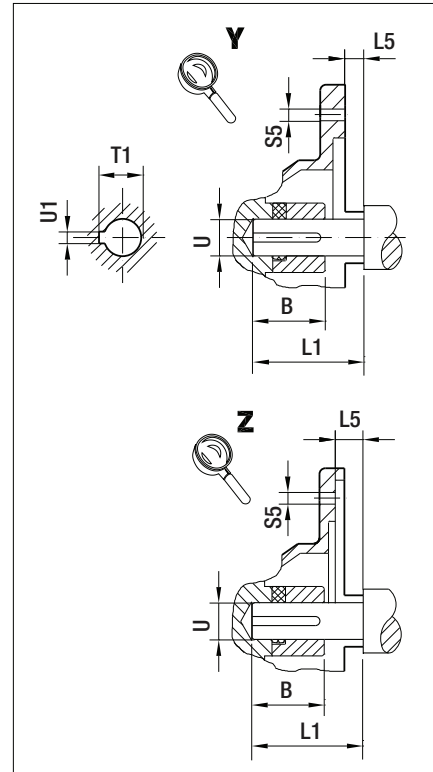
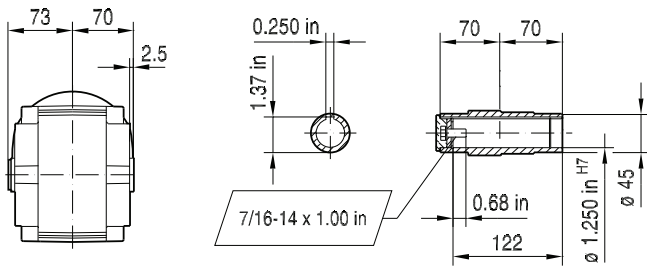

WH47..

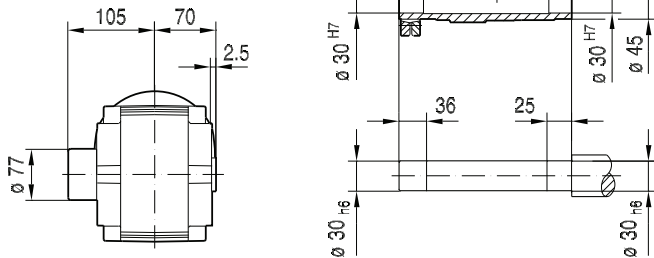

(→ 132)	B	B5	C5	E5	F5	G5	L	L1	L5	S5	T1	U	U1	Z5
AM56	1.23 in	4.50 in	11	5.875 in	4.5	170	347	1.88 in	-0.18 in	10.5	0.71 in	0.625 in	0.188 in	87
AM143	1.68 in	4.50 in	12	5.875 in	4.5	170	371	2.25 in	0.13 in	10.5	0.98 in	0.875 in	0.188 in	110.5
AM145	1.68 in	4.50 in	12	5.875 in	4.5	170	371	2.25 in	0.13 in	10.5	0.98 in	0.875 in	0.188 in	110.5
AM182	2.10 in	8.50 in	10	7.25 in	5	228	408	2.75 in	0.13 in	15	1.24 in	1.125 in	0.250 in	147.5
AM184	2.10 in	8.50 in	10	7.25 in	5	228	408	2.75 in	0.13 in	15	1.24 in	1.125 in	0.250 in	147.5

Note: Dimensions in mm unless otherwise noted. For all available output shaft diameters, see page 710.

WT47..

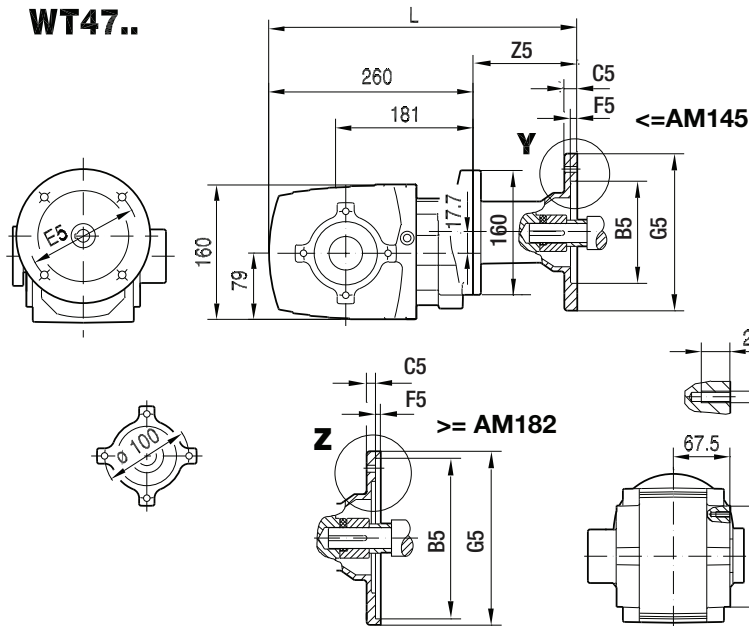

20 019 00 11

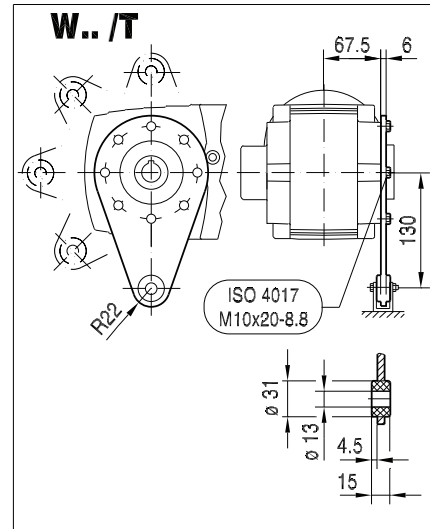

NON-Symmetrical

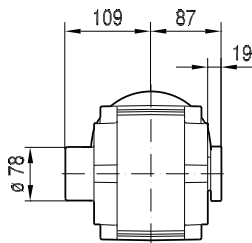

Symmetrical

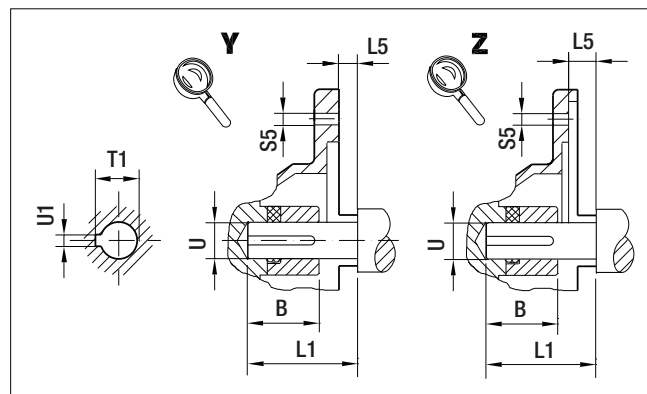
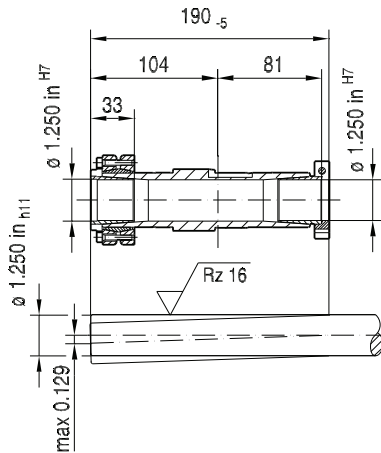
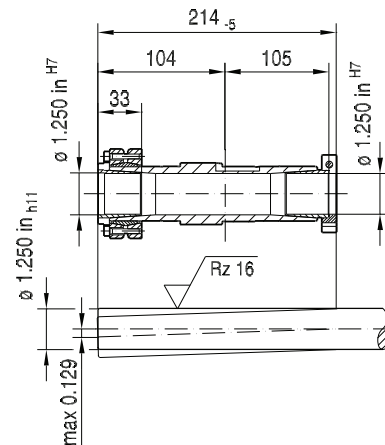
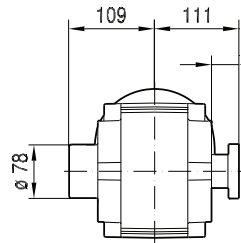

(→ 132)	B	B5	C5	E5	F5	G5	L	L1	L5	S5	T1	U	U1	Z5
AM56	1.23 in	4.50 in	11	5.875 in	4.5	170	347	1.88 in	-0.18 in	10.5	0.71 in	0.625 in	0.188 in	87
AM143	1.68 in	4.50 in	12	5.875 in	4.5	170	371	2.25 in	0.13 in	10.5	0.98 in	0.875 in	0.188 in	110.5
AM145	1.68 in	4.50 in	12	5.875 in	4.5	170	371	2.25 in	0.13 in	10.5	0.98 in	0.875 in	0.188 in	110.5
AM182	2.10 in	8.50 in	10	7.25 in	5	228	408	2.75 in	0.13 in	15	1.24 in	1.125 in	0.250 in	147.5
AM184	2.10 in	8.50 in	10	7.25 in	5	228	408	2.75 in	0.13 in	15	1.24 in	1.125 in	0.250 in	147.5

Note: Dimensions in mm unless otherwise noted. For all available output shaft diameters, see page 712.

12.4 W.. AM.. [IEC dimensions]

23 002 100

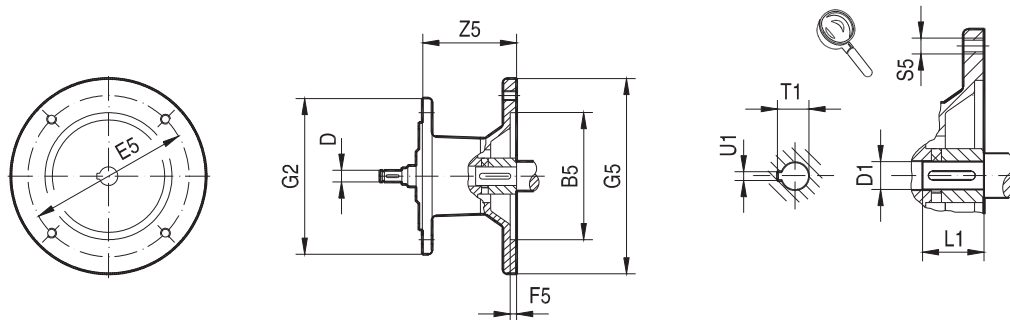

Gear unit type	Adapter type	Dimensions in mm											
		B5	D	E5	F5	G2	G5	S5	Z5	D1	L1	T1	U1
W..37	AM63	95	10	115	3.5	120	140	M8	72	11	23	12.8	4
	AM71 ¹⁾	110		130	4		160			14	30	16.3	5
	AM80 ¹⁾	130	12	165	4.5		200	M10	106	19	40	21.8	6
	AM90 ¹⁾		14							24	50	27.3	8
W..47	AM63	95	10	115	3.5	160	140	M8	66	11	23	12.8	4
	AM71	110		130	4		160			14	30	16.3	5
	AM80	130	12	165	4.5		200	M10	99	19	40	21.8	6
	AM90		14							24	50	27.3	8
	AM100 ¹⁾	180	16	215	5		250	M12	134	28	60	31.3	8
	AM112 ¹⁾		18										
	AM132S/M ¹⁾	230	22	265			300	191	38	80	41.3	10	

1) Check dimension (G5)/2 as adapter may protrude past the bottom of the feet on a foot-mounted gear unit.

12.5 W.. AD.. [dimensions]

12.5.1 Input shaft - Inch

20 010 01 07US

W.. AD..

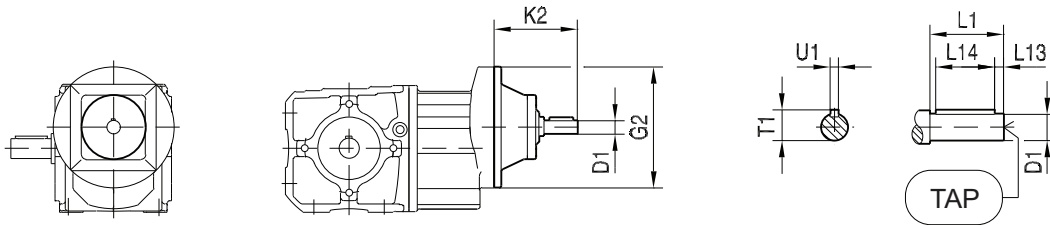

12

		D1	G2	K2	L1	L13	L14	T1	U1	TAP (inch)
W..37	AD1	0.625 in	120	102	40	4	32	0.70 in	0.1875 in	1/4-20 x0.63
	AD2	0.750 in		130	40	4	32	0.83 in		
W..47	AD2	0.750 in	160	123	40	4	32	0.83 in	0.1875 in	1/4-20 x0.63
	AD3	0.875 in		159	50	5	40	0.96 in		5/16-18 x0.87

12.5.2 Input shaft - Metric

20 010 01 07

W.. AD..

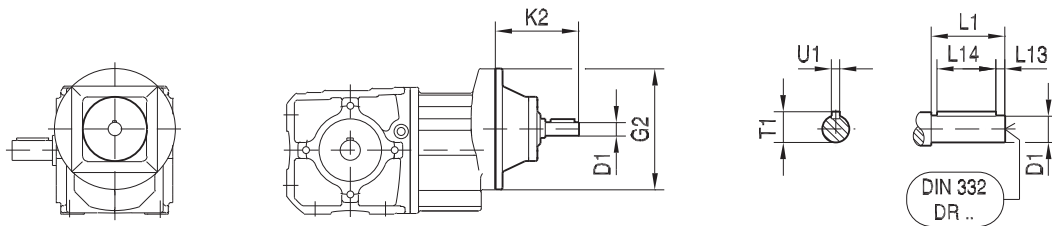

		D1	G2	K2	L1	L13	L14	T1	U1
W..37	AD1	16	120	102	40	4	32	18	5
	AD2	19		130	40	4	32	21.5	6
W..47	AD2	19	160	123	40	4	32	21.5	6
	AD3	24		159	50	5	40	27	8

12.6 W.. AR.. [dimensions]

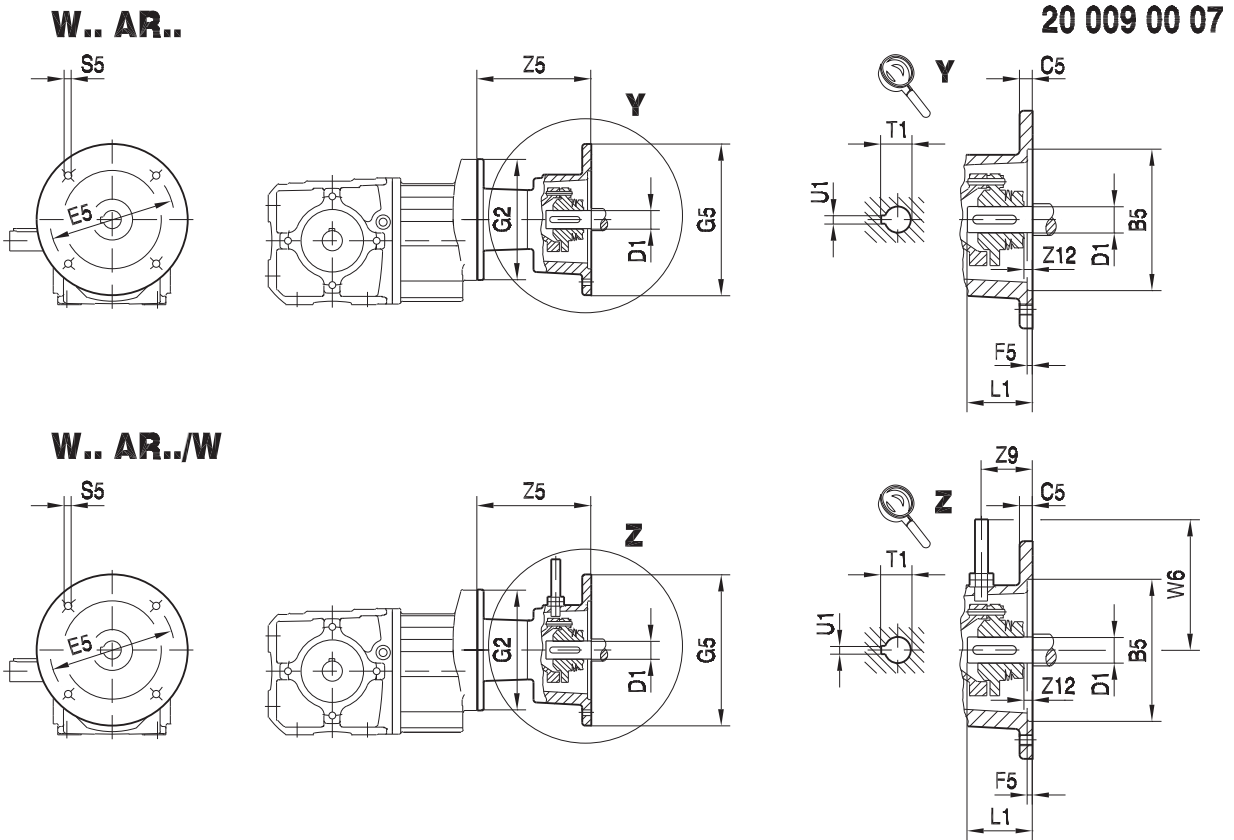

		B5	C5	E5	F5	G2	G5	S5	W6	Z5	Z9	Z12	D1	L1	T1	U1
W..37	AR71	110	10	130	3.5	120	160	M8	120	104	37	0	14	30	16.3	5
	AR80	130	12	165	4.5		200	M10		140.5			19	40	21.8	6
	AR90						24	50		27.3			8			
W..47	AR71	110	10	130	3.5	160	160	M8	120	104	37	0	14	30	16.3	5
	AR80	130	12	165	4.5		200	M10		134			19	40	21.8	6
	AR90						24	50		27.3			8			

12.7 Output shaft sizes

12.7.1 Solid shafts - Inch

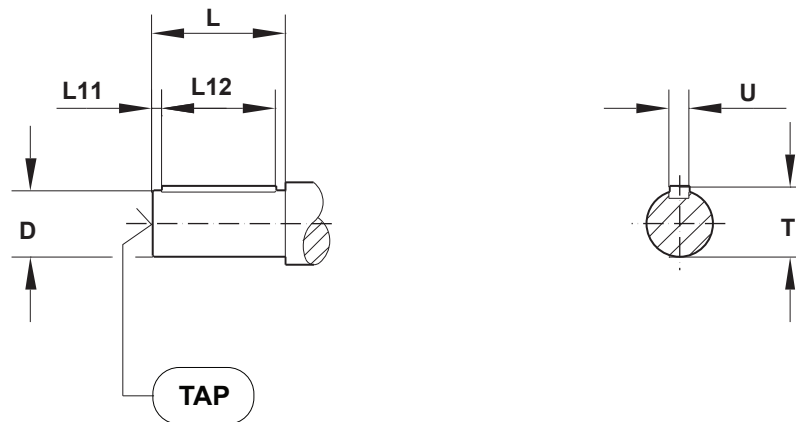

All dimensions in inches							
Model	D	T	U	L	L11	L12	TAP
W10	0.625	0.71	3/16	1.57	0.25	1-1/16	1/4 - 20 x 0.63
W20	0.750	0.83	3/16	1.57	0.25	1-1/16	1/4 - 20 x 0.63
W30	0.750	0.83	3/16	1.57	0.25	1-1/16	1/4 - 20 x 0.63
W37	0.750	0.83	3/16	1.57	0.25	1-1/16	1/4 - 20 x 0.63
W47	1.250	1.36	1/4	2.36	0.26	1-11/16	1/2 - 13 x 1.12

12.7.2 Solid shafts - Metric

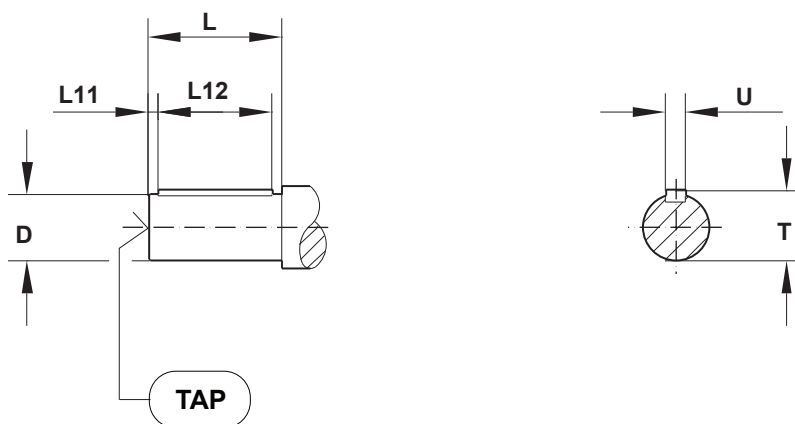

All dimensions in mm							
Model	D	T	U	L	L11	L12	TAP
W10	16	18	5	40	4	32	M5 x 12.5
W20	20	22.5	6	40	4	32	M6 x 16
W30	20	22.5	6	40	4	32	M6 x 16
W37	20	22.5	6	40	4	32	M6 x 16
W47	30	33	8	60	3.5	50	M10 x 22

12.7.3 Hollow shafts - Inch

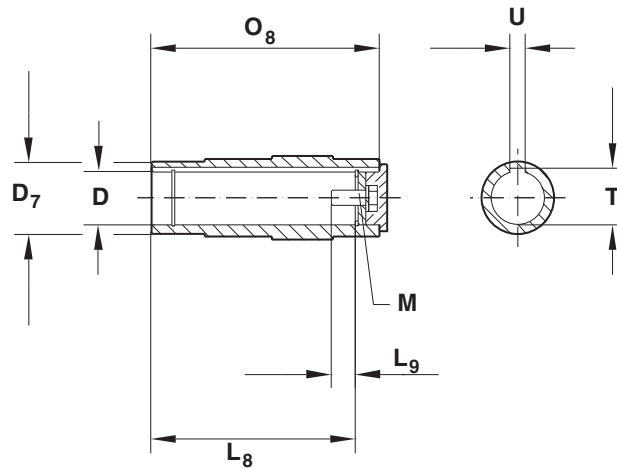

All dimensions in inches								
Model	D	D ₇	O ₈	T	U	L ₈	L ₉	M
WA10	0.625	0.98	3.31	0.71	3/16	3.11	0.50	1/4 - 20 x 5/8
WA20	0.75	1.18	3.94	0.85	3/16	3.31	0.35	1/4 - 20 x 5/8
WA30	0.75	1.18	4.76	0.85	3/16	4.13	0.35	1/4 - 20 x 5/8
WA37	0.75	1.38	4.76	0.85	3/16	4.13	0.35	1/4 - 20 x 5/8
WA47	1.00	1.77	5.51	1.12	1/4	4.80	0.68	3/8 - 16 x 1
	1.25	1.77	5.51	1.37	1/4	4.80	0.68	7/16 - 14 x 1

12.7.4 Hollow shafts - Metric

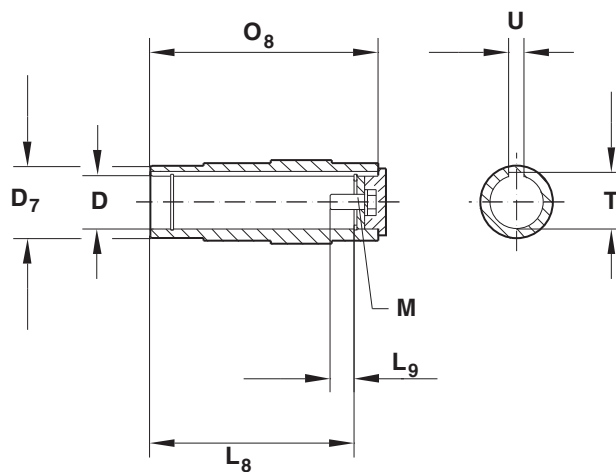

All dimensions in mm								
Model	D	D ₇	O ₈	T	U	L ₈	L ₉	M
WA10	14	25	84	16.3	5	69	10	M5 x 16
	16	25	84	18.3	5	69	8	M5 x 12
WA20	18	30	100	20.8	6	84	9	M6 x 16
	20	30	100	22.8	6	84	8	M6 x 16
WA30	20	30	121	22.8	6	105	8	M6 x 16
WA37	20	35	121	22.8	6	105	8	M6 x 16
	25	35	121	27	8	105	17	M10 x 25
WA47	30	45	140	33.3	8	122	17	M10 x 25

12.7.5 TorqLOC keyless hollow shaft

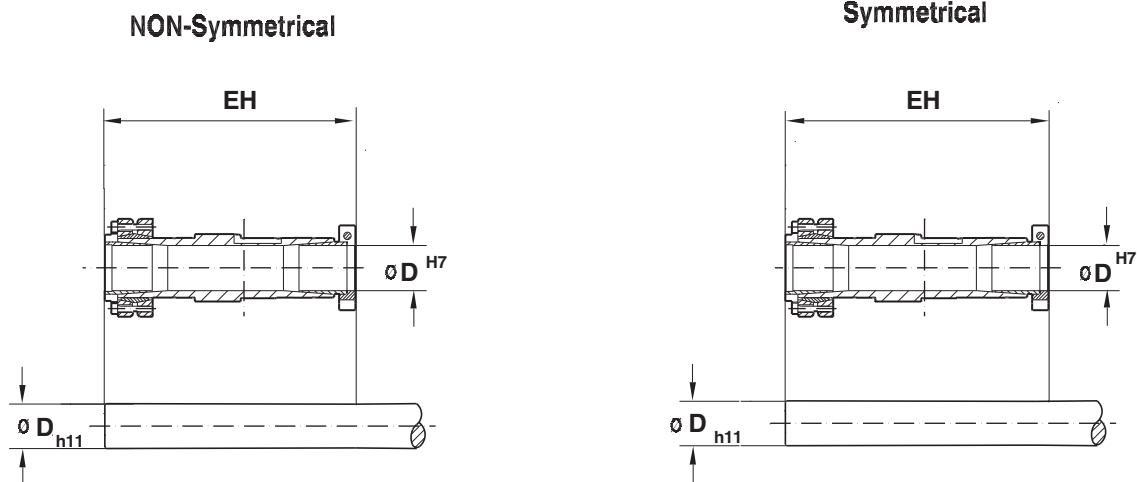

Metric and inch bores are available as shown below.

Model	D (in)					D (mm)			EH (inches)	
	Inch Bores					Metric Bores			NON-Symmetrical	Symmetrical
WT37	0.625	0.6875	0.75	-	-	16	19	20	6.54	7.33
WT47	1.00	1.1875	1.25	-	-	25	30	-	6.69	7.63

13 Address Directory

Assembly Sales Offices	Ohio	SEW-EURODRIVE INC. 2001 West Main Street Troy, Ohio 45373	Tel. 937 335-0036 Fax 937 440-3799 cstroy@seweurodrive.com
	New Jersey	SEW-EURODRIVE INC. Pureland Ind. Complex 2107 High Hill Road, P.O. Box 481 Bridgeport, New Jersey 08014	Tel. 856 467-2277 Fax 856 845-3179 csbridgeport@seweurodrive.com
	South Carolina	SEW-EURODRIVE INC. 1295 Old Spartanburg Highway P.O. Box 518 Lyman, SC 29365	Tel. 864 439-7537 Fax 864 439-7830 cslyman@seweurodrive.com
	Texas	SEW-EURODRIVE INC. 3950 Platinum Way Dallas, Texas 75237	Tel. 214 330-4824 Fax 214 330-4724 csdallas@seweurodrive.com
	California	SEW-EURODRIVE INC. 30599 San Antonio St. Hayward, CA 94544	Tel. 510 487-3560 Fax 510 487-6381 cshayward@seweurodrive.com
Manufacturing	South Carolina	SEW-EURODRIVE INC. 1275 Old Spartanburg Highway P.O. Box 518 Lyman, SC 29365	Tel. 864 439-8792 Fax 864 439-9948 www.seweurodrive.com
Large Industrial Gear Assembly	South Carolina	SEW-EURODRIVE INC. 150 Finch Road Wellford, SC 29385	Tel. 864 439-7537 www.seweurodrive.com
District Sales Offices	Alabama	Bob Whittlesey 5374 Pineywood Rd. Birmingham, AL 35242	Tel. 205 408-8886 Fax 205 917-5388 bwhittlesey@seweurodrive.com
	Alaska	William A. Aschenbrenner 411 East Aycliffe Dr. Shelton, WA 98584	Tel./Fax 360 358-8132 Mobile 206 618-7984 baschenbrenner@seweurodrive.com
	Arizona	Rick A. Burdick 3942 Canyon Terrace Yorba Linda, CA 92886	Tel./Fax 714 970-6197 Mobile 714 342-8228 rburdick@seweurodrive.com
	Arkansas	Ed Lockett 1402 Trails Edge Drive Conway, AR 72032	Tel. 501 336-7274 Fax 877 296-3833 elockett@seweurodrive.com
	California	Rick A. Burdick 3942 Canyon Terrace Yorba Linda, CA 92886	Tel./Fax 714 970-6197 Mobile 714 342-8228 rburdick@seweurodrive.com
		Michael Haskins 7750 Chisamore Ranch Lane Vacaville, CA 95688	Tel./Fax 707 453-1550 Mobile 707 494-9388 mhaskins@seweurodrive.com
		Steve Highley 14346 Alicante Drive La Mirada, CA 90638	Tel./Fax 562 944-2764 Mobile 323 219-9681 shighley@seweurodrive.com
		John McNamee 5610 Havencrest Circle Stockton, CA 95219	Tel./Fax 209 473-4887 Mobile 209 481-6928 jmnamee@seweurodrive.com
	Colorado	Kevin Savage 11984 Blakeford Street Parker, CO 80134	Mobile 303 522-1251 Fax 303 346-9410 ksavage@seweurodrive.com
Connecticut	Matthew Zurell 299 Brook Street Bristol, CT 06010	Tel. 860 584-0165 Fax 856 845-3179 csbridgeport@seweurodrive.com	

District Sales Offices (cont.)	Delaware	Joshua Rossell 108A South Warner Street Woodbury, NJ 08096	Tel. 856 689-1882 jrossell@seweurodrive.com
	District of Columbia	Joshua Rossell 108A South Warner Street Woodbury, NJ 08096	Tel. 856 689-1882 jrossell@seweurodrive.com
	Florida	Tony O. Toledo 901 25 th Avenue W. Palmetto, FL 34221	Tel. 941 729-0717 Mobile 941 720-2766 ttoledo@seweurodrive.com
		Bob Whittlesey 5374 Pineywood Rd. Birmingham, AL 35242	Tel. 205 408-8886 Fax 205 917-5388 bwhittlesey@seweurodrive.com
		David Buccellato 4324 85th Avenue Circle E Parrish, FL 34219	Tel. 941 962-8122 Fax 941 847-0607 dbuccellato@seweurodrive.com
	Georgia	Jim Garrett 3843 Boulder Creek Road Martinez, GA 30907	Tel. 706 210-0116 / 706 399-9272 Fax 706 228-4990 jgarrett@seweurodrive.com
		William Huffstetler 1351 Matts Lane Watkinsville, GA 30677	Tel. 678 294-7224 whuffstetler@seweurodrive.com
		Abraham Masourian 1955 Nocturne Dr #3404 Alpharetta, GA 30009-4830	Tel. 770 674-4828 / 678 448-7173 Fax 888 761-5517 amasourian@seweurodrive.com
	Idaho	Duwayne Hogan 6154 W. Majestic Ave Rathdrum, ID 83858	Tel. 208 772-8184 Mobile 208 699-6475 dhogan@seweurodrive.com
		Steven Jacobson 5520 S. 225 E. Ogden, UT 84405	Tel. 801 612-9558 Mobile 801 554-7770 sjacobson@seweurodrive.com
	Illinois	Tom Ellis 24146 Brancaster Dr. Naperville, IL 60564	Tel. 630 579-4500 / 815 878-0032 Fax 630 579-4540 tellis@seweurodrive.com
		Dan Wittenberg 509 N. Wooster Street Algona, IA 50511	Tel. 515 320-0508 Fax 888 313-1413 dwittenberg@seweurodrive.com
		Scott R. Johnson 52 Boxwood Lane Cary, IL 60013	Tel. 847 639-9774 / 847 682-3992 Fax 847 639-9775 sjohnson@seweurodrive.com
		Brent Collum 8134 Stonereath Ct. Indianapolis, IN 46237	Tel 317 412-4221 bcollum@seweurodrive.com
		Hans Rodgers 1813 N. Lake Sherwood Dr / POB 1326 Lake Sherwood, MO 63357	Tel. 636 828-5288 Mobile 314 441-9249 hrodgers@seweurodrive.com
		Jeffrey L. Westrom 2 S. 111 Stratford Road Glen Ellyn, IL 60137	Tel. 630 790-2868 / 630 707-4327 Fax 630 790-2878 jwestrom@seweurodrive.com

District Sales Offices (cont.)	Indiana	Tom Ellis 24146 Brancaster Dr. Naperville, IL 60564	Tel. 630 579-4500 / 815 878-0032 Fax 630 579-4540 tellis@seweurodrive.com
		Brent Collum 8134 Stonereath Ct. Indianapolis, IN 46237	Tel 317 412-4221 bcollum@seweurodrive.com
		Jay Kunz 5723 Taylorsville Road Fisherville, KY 40023	Tel. 502 477-7257 Mobile 502 744-9033 jkunz@seweurodrive.com
		Mike Kushman 20610 Sugar Ridge Lane Lawrenceburg, IN 47025	Tel. 812 537-9318 / 513 518-2535 Fax 812 537-4268 mkushman@seweurodrive.com
	Iowa	Dan Wittenberg 509 N. Wooster Street Algona, IA 50511	Tel. 515 320-0508 Fax 888 313-1413 dwittenberg@seweurodrive.com
		Tim Taylor 18308 Mason Street Elkhorn, NE 68022	Tel. 402 670-6915 Fax 877 589-9883 ttaylor@seweurodrive.com
	Kansas	John Mikovsky 6721 West 128th Place #102 Overland Park, KS 66209	Tel. 314 520-6523 Fax 866 752-0169 jmikovsky@seweurodrive.com
	Kentucky	Jay Kunz 5723 Taylorsville Road Fisherville, KY 40023	Tel. 502 477-7257 Mobile 502 744-9033 jkunz@seweurodrive.com
		Mike Kushman 20610 Sugar Ridge Lane Lawrenceburg, IN 47025	Tel. 812 537-9318 / 513 518-2535 Fax 812 537-4268 mkushman@seweurodrive.com
		Hans Rodgers 1813 N. Lake Sherwood Dr / POB 1326 Lake Sherwood, MO 63357	Tel. 636 828-5288 Mobile 314 441-9249 hrodgers@seweurodrive.com
	Louisiana	Sheldon Anderson 4515 Tartan Drive Baton Rouge, LA 70816	Tel. 225 588-3255 Fax 888 522-9013 sanderson@seweurodrive.com
	Maine	Kevin Molloy 31 Dover Eliot Road South Berwick, ME 03908	Tel. 603 659-3361 / 603 817-5042 Fax 866 878-2843 kmolloy@seweurodrive.com
Maryland	John Shoop 4 Colonial Court Milton, PA 17847	Tel. 570 713-1593 / 570 579-1034 Fax 866 775-1595 jshoop@seweurodrive.com	
	Joshua Rossell 108A South Warner Street Woodbury, NJ 08096	Tel. 856 689-1882 jrossell@seweurodrive.com	
Massachusetts	Matthew Zurell 299 Brook Street Bristol, CT 06010	Tel. 860 584-0165 Fax 856 845-3179 csbridgeport@seweurodrive.com	
	Kevin Molloy 31 Dover Eliot Road South Berwick, ME 03908	Tel. 603 659-3361 / 603 817-5042 Fax 866 878-2843 kmolloy@seweurodrive.com	

District Sales Offices (cont.)	Michigan	Flaherty Electro-Mechanical Products, Inc: Dirk Lockwood Drew Lockwood Tom Verhil Patrick Miller 6026 Kalamazoo Ave. #180 Kentwood, MI 49508	Tel. 800 917-6030 Fax 866 953-1119 dlockwood@seweurodrive.com (Dirk) djlockwood@seweurodrive.com (Drew) tverhil@seweurodrive.com pmiller@seweurodrive.com
		Automotive Technical Sales Center 51183 West Pontiac Trail Wixom, MI 48393	Tel. 248 668-0404 Fax 248 668-9363 tcurtin@seweurodrive.com
		Jeff Robinson 17443 Harley Woods Drive Bowling Green, OH 43402	Tel. 419 823-0920 Fax 888 552-6803 jrobinson@seweurodrive.com
	Minnesota	Andy Semelis 154 147 th Street Deer Park, WI 54007	Tel. 715 248-4892 / 612 743-9622 Fax 888 371-7537 asemelis@seweurodrive.com
	Mississippi	Sheldon Anderson 4515 Tartan Drive Baton Rouge, LA 70816	Tel. 225 588-3255 Fax 888 522-9013 sanderson@seweurodrive.com
	Missouri	Hans Rodgers 1813 N. Lake Sherwood Dr / POB 1326 Lake Sherwood, MO 63357	Tel. 636 828-5288 Mobile 314 441-9249 hroddgers@seweurodrive.com
		John Mikovsky 6721 West 128th Place #102 Overland Park, KS 66209	Tel. 314 520-6523 Fax 866 752-0169 jmikovsky@seweurodrive.com
	Montana	Duwayne Hogan 6154 W. Majestic Ave Rathdrum, ID 83858	Tel. 208 772-8184 Mobile 208 699-6475 dhogan@seweurodrive.com
	Nebraska	Tim Taylor 18308 Mason Street Elkhorn, NE 68022	Tel. 402 670-6915 Fax 877 589-9883 ttaylor@seweurodrive.com
	Nevada	Rick A. Burdick 3942 Canyon Terrace Yorba Linda, CA 92886	Tel./Fax 714 970-6197 Mobile 714 342-8228 rburdick@seweurodrive.com
		Michael Haskins 7750 Chisamore Ranch Lane Vacaville, CA 95688	Tel./Fax 707 453-1550 Mobile 707 494-9388 mhaskins@seweurodrive.com
	New Hampshire	Kevin Molloy 31 Dover Eliot Road South Berwick, ME 03908	Tel. 603 659-3361 / 603 817-5042 Fax 866 878-2843 kmolloy@seweurodrive.com
	New Jersey	Edward McLaughlin 7 Ridgeview Lane Port Jervis, NY 12771	Tel. 845 856-8811 / 914 213-9620 Fax 845 839-2796 emcloughlin@seweurodrive.com
		Joshua Rossell 108A South Warner Street Woodbury, NJ 08096	Tel. 856 689-1882 jrossell@seweurodrive.com
	New Mexico	Kevin Savage 11984 Blakeford Street Parker, CO 80134	Mobile 303 522-1251 Fax 303 346-9410 ksavage@seweurodrive.com

District Sales Offices (cont.)	New York	Art Conner 8710 Wenner Rd. Clarence, NY 14221	Tel. 716 695-7728 aconner@seweurodrive.com
		Richard Maggio 38 Roe Street Melville, NY 11747	Tel. 631 549-8750 / 631 767-8478 Fax 631 351-0872 rmaggio@seweurodrive.com
		Edward McLaughlin 7 Ridgeview Lane Port Jervis, NY 12771	Tel. 845 856-8811 / 914 213-9620 Fax 845 839-2796 emcloughlin@seweurodrive.com
		Scott Eno P.O. Box 551 Cazenovia, NY 13035	Tel. 315 815-4078 Fax 315 679-4792 Mobile 315-412-3596 seno@seweurodrive.com
	North Carolina	Brent Craft 4004 Smithfield Road Greensboro, NC 27406	Mobile 336 339-9997 Fax 336 790-8614 bcraft@seweurodrive.com
		Jack F. Jung 117 N. Brackenbury Lane Charlotte, NC 28270	Tel. 704 362-2674 / 704 564-1423 Fax 704 362-2961 jjung@seweurodrive.com
	North Dakota	Tim Taylor 18308 Mason Street Elkhorn, NE 68022	Tel. 402 670-6915 Fax 877 589-9883 ttaylor@seweurodrive.com
	Ohio	Lowell Bishop 4080 Bayberry Court Columbus, OH 43220	Tel. 614 538-0880 / 614 370-4517 Fax 614 538-0889 lbishop@seweurodrive.com
		Scott Walkup 456 Robin Hood Lane Troy, OH 45373	Tel. 937 216-2775 Fax 888 852-8682 swalkup@seweurodrive.com
		Mike Kushman 20610 Sugar Ridge Lane Lawrenceburg, IN 47025	Tel. 812 537-9318 / 513 518-2535 Fax 812 537-4268 mkushman@seweurodrive.com
		Jeff Robinson 17443 Harley Woods Drive Bowling Green, OH 43402	Tel. 419 823-0920 Fax 888 552-6803 jrobinson@seweurodrive.com
		Bob Schmidt 3786 Briarton Ct. Stow, OH 44224	Tel. 330 688-0662 / 330 697-4810 Fax 330 678-2446 bschmidt@seweurodrive.com
	Oklahoma	Floyd Rainey 3950 Platinum Way Dallas, TX 75237	Tel. 214 330-4824 Fax 214 330-4724 frainey@seweurodrive.com
	Oregon	Michael S. Johnson 15804 N.E. 160 Ct. Brush Prairie, WA 98606	Tel./Fax 360 256-1785 Mobile 503 780-1833 mjohnson@seweurodrive.com
	Pennsylvania	John Rauch 1216 Hamilton Drive West Chester, PA 19380	Tel. 610 344-7296 Mobile 610 417-5519 jrauch@seweurodrive.com
		Lance Hornberger 63 Hollow Road Ringtown, PA 17967	Tel. 570 985-8409 Fax 570 227-0081 Lhornberger@seweurodrive.com
		Tim Phaturos 206 Birch Avenue Pittsburgh, PA 15237	Tel. 412 366-3563 / 412 807-1271 FAX 888 665-4616 tphaturos@seweurodrive.com
		John Shoop 4 Colonial Court Milton, PA 17847	Tel. 570 713-1593 Fax 866 775-1595 jshoop@seweurodrive.com
	Rhode Island	Kevin Molloy 31 Dover Eliot Road South Berwick, ME 03908	Tel. 603 659-3361 / 603 817-5042 Fax 866 878-2843 kmolloy@seweurodrive.com

District Sales Offices (cont.)	South Carolina	Bill Kinard 20 Wrenwood Court Greer, SC 29651	Tel. 864 288-2725 Mobile 864 907-5750 bkinard@seweurodrive.com
	South Dakota	Tim Taylor 18308 Mason Street Elkhorn, NE 68022	Tel. 402 670-6915 Fax 877 589-9883 ttaylor@seweurodrive.com
	Tennessee	Todd Styles 310B East View Drive Chattanooga, TN 37404	Tel. 423 991-8320 / 423 598-1090 Fax 888 849-4186 tstyles@seweurodrive.com
	Texas	John Hill 6846 Cedar Cove Road Belton, TX 76513	Tel. 254 718-5210 Fax 254 213-6131 jhill@seweurodrive.com
		Luke Bonlie 18231 Tacoma Ridge Dr. Tomball, TX 77377	Tel. 281 202-5800 Fax 888 555-5814 Lbonlie@seweurodrive.com
		Ryan Hill 5625 Live Oak Street Dallas, TX 75206	Tel. 214 796-9244 Fax 214 853-5005 rhill@seweurodrive.com
		Floyd Rainey 3950 Platinum Way Dallas, TX 75237	Tel. 214 330-4824 Fax 214 330-4724 frainey@seweurodrive.com
		John Langsdorf 3950 Platinum Way Dallas, TX 75237	Tel. 817 718-2691 Fax 817 796-1612 jlangsdorf@seweurodrive.com
	Utah	Steven Jacobson 5520 S. 225 E. Ogden, UT 84405	Tel. 801 612-9558 Mobile 801 554-7770 sjacobson@seweurodrive.com
	Vermont	Kevin Molloy 31 Dover Eliot Road South Berwick, ME 03908	Tel. 603 659-3361 / 603 817-5042 Fax 866 878-2843 kmolloy@seweurodrive.com
	Virginia	Todd Bauer 1188 New Hope Rd. Staunton, VA 24401	Tel. 540 248-2420 / 540 569-0012 Fax 866 522-1952 tbauer@seweurodrive.com
	Virginia	Mike Nojaim 13606 Winterberry Ridge Midlothian, VA 23112	Tel. 804 744-2179 / 804 347-6495 Fax 757 282-5800 mnojaim@seweurodrive.com
	Washington	William A. Aschenbrenner 411 East Aycliffe Dr. Shelton, WA 98584	Tel./Fax 360 358-8132 Mobile 206 618-7984 baschenbrenner@seweurodrive.com
		Duwayne Hogan 6154 W. Majestic Ave Rathdrum, ID 83858	Tel. 208 772-8184 Mobile 208 699-6475 dhogan@seweurodrive.com
		Michael S. Johnson 15804 N.E. 160 Ct. Brush Prairie, WA 98606	Tel./ Fax 360 256-1785 Mobile 503 780-1833 mjohnson@seweurodrive.com
	West Virginia	Lowell Bishop 4080 Bayberry Court Columbus, OH 43220	Tel. 614 538-0880 / 614 370-4517 Fax 614 538-0889 Lbishop@seweurodrive.com
		Todd Bauer 1188 New Hope Rd. Staunton, VA 24401	Tel. 540 248-2420 / 540 569-0012 Fax 866 522-1952 tbauer@seweurodrive.com
		Mike Kushman 20610 Sugar Ridge Lane Lawrenceburg, IN 47025	Tel. 812 537-9318 / 513 518-2535 Fax 812 537-4268 mkushman@seweurodrive.com

District Sales Offices (cont.)	Wisconsin	Scott Shaw W134 N6148 Tall Oak Ct. Menomonee Falls, WI 53051	Tel. 262 825-2032 / 262 825-2138 Fax 262 347-3230 sshaw@seweurodrive.com
		Dan Wittenberg 509 N. Wooster Street Algona, IA 50511	Tel. 515 320-0508 Fax 888 313-1413 dwittenberg@seweurodrive.com
		Andy Semelis 154 147 th Street Deer Park, WI 54007	Tel. 715 248-4892 / 612 743-9622 Fax 888 371-7537 asemelis@seweurodrive.com
		Walter Sturgeon 7645 West Cleveland Avenue West Allis, WI 53219	Tel. 414 321-8472 / 414 418-9993 Fax 414 321-8473 wsturgeon@seweurodrive.com
	Wyoming	Kevin Savage 11984 Blakeford Street Parker, CO 80134	Mobile 303 522-1251 Fax 303 346-9410 ksavage@seweurodrive.com
		Steven Jacobson 5520 S. 225 E. Ogden, UT 84405	Tel. 801 612-9558 Mobile 801 554-7770 sjacobson@seweurodrive.com
		Duwayne Hogan 6154 W. Majestic Ave Rathdrum, ID 83858	Tel. 208 772-8184 Mobile 208 699-6475 dhogan@seweurodrive.com

Canada			
Assembly Sales Service	Toronto	SEW-EURODRIVE CO. OF CANADA LTD. 210 Walker Drive Bramalea, ON L6T 3W1	Tel. +1 905 791-1553 Fax +1 905 791-2999 www.sewcan.ca l.watson@sew-eurodrive.ca
	Vancouver	SEW-EURODRIVE CO. OF CANADA LTD. Tilbury Industrial Park 7188 Honeyman Street Delta, BC V4G 1G1	Tel. +1 604 946-5535 Fax +1 604 946-2513 b.wake@sew-eurodrive.ca
	Montreal	SEW-EURODRIVE CO. OF CANADA LTD. 2555 Rue Leger Lasalle, PQ H8N 2V9	Tel. +1 514 367-1124 Fax +1 514 367-3677 a.peluso@sew-eurodrive.ca
Additional addresses for service in Canada provided on request!			

Mexico			
Assembly Sales Service	Quéretaro	SEW-EURODRIVE MEXICO SA DE CV SEM-981118-M93 Tequisquiapan No. 102 Parque Industrial Quéretaro C.P. 76220 Quéretaro, México	Tel. +52 442 1030-300 Fax +52 442 1030-301 www.mx.sew-eurodrive.com scmexico@seweurodrive.com.mx

Algeria			
Sales	Alger	REDUCOM Sarl 16, rue des Frères Zaghounne Bellevue 16200 El Harrach Alger	Tel. +213 21 8214-91 Fax +213 21 8222-84 info@reducom-dz.com www.reducom-dz.com

Argentina			
Assembly Sales	Buenos Aires	SEW EURODRIVE ARGENTINA S.A. Centro Industrial Garin, Lote 35 Ruta Panamericana Km 37,5 1619 Garin	Tel. +54 3327 4572-84 Fax +54 3327 4572-21 sewar@sew-eurodrive.com.ar www.sew-eurodrive.com.ar
Australia			
Assembly Sales Service	Melbourne	SEW-EURODRIVE PTY. LTD. 27 Beverage Drive Tullamarine, Victoria 3043	Tel. +61 3 9933-1000 Fax +61 3 9933-1003 www.sew-eurodrive.com.au enquires@sew-eurodrive.com.au
	Sydney	SEW-EURODRIVE PTY. LTD. 9, Sleigh Place, Wetherill Park New South Wales, 2164	Tel. +61 2 9725-9900 Fax +61 2 9725-9905 enquires@sew-eurodrive.com.au
Sales Service	Adelaide	SEW-EURODRIVE PTY. LTD. 9C Park Way Mawson Lakes, SA 5095	Tel. +61 8 8161 4000 Fax +61 8 8161 4002 enquires@sew-eurodrive.com.au
	Brisbane	SEW-EURODRIVE PTY.LTD. 1 /34 Collinsvale St Rocklea, Queensland, 4106	Tel. +61 7 3276 5100 Fax +61 7 3276 5102 enquires@sew-eurodrive.com.au
	Perth	SEW-EURODRIVE PTY. LTD. 10 Colin Jamieson Drive Welshpool, WA 6106	Tel. +61 8 9251-4900 Fax +61 8 9251-4903 enquires@sew-eurodrive.com.au
Austria			
Assembly Sales Service	Wien	SEW-EURODRIVE Ges.m.b.H. Richard-Strauss-Strasse 24 A-1230 Wien	Tel. +43 1 617 55 00-0 Fax +43 1 617 55 00-30 www.sew-eurodrive.at sew@sew-eurodrive.at
Bangladesh			
Sales	Bangladesh	SEW-EURODRIVE INDIA PRIVATE LIMITED Genetic Udayanchal, House-96 (6th Floor), Road-23/A, Block-B, Banani, Dhaka-1213, Bangladesh	Mobile +88 01729 097309 salesdhaka@seweurodrivebangladesh.com
Belarus			
Sales	Minsk	SEW-EURODRIVE BY RybalkoStr. 26 BY-220033 Minsk	Tel.+375 17 298 47 56 / 298 47 58 Fax +375 17 298 47 54 www.sew.by sales@sew.by
Belgium			
Assembly Sales Service	Brussels	SEW-EURODRIVE Researchpark Haasrode 1060 Evenementenlaan 7 BE-3001 Leuven	Tel. +32 16 386-311 Fax +32 16 386-336 www.sew-eurodrive.be info@sew-eurodrive.be
Service Competence Center	Industrial Gears	SEW-EURODRIVE Rue de Parc Industriel, 31 BE-6900 Marche-en-Famenne	Tel. +32 84 219-878 Fax +32 84 219-879 www.sew-eurodrive.be service-wallonie@sew-eurodrive.be

Brazil			
Production Sales Service	Sao Paulo	SEW-EURODRIVE Brasil Ltda. Avenida Amâncio Gaiolli, 152 - Rodovia Presidente Dutra Km 208 Guarulhos - 07251-250 - SP SAT - SEW ATENDE - 0800 7700496	Tel. +55 11 2489-9133 Fax +55 11 2480-3328 www.sew-eurodrive.com.br sew@sew.com.br
Bulgaria			
Sales	Sofia	BEVER-DRIVE GmbH Bogdanovetz Str.1 BG-1606 Sofia	Tel. +359 2 9151160 Fax +359 2 9151166 bever@bever.bg
Cameroon			
Sales	Douala	Electro-Services Rue Drouot Akwa B.P. 2024 Douala	Tel. +237 33 431137 Fax +237 33 431137 electrojamba@yahoo.fr
Chile			
Assembly Sales Service	Santiago de Chile	SEW-EURODRIVE CHILE LTDA. Las Encinas 1295 Parque Industrial Valle Grande LAMPA RCH-Santiago de Chile P.O. Box Casilla 23 Correo Quilicura - Santiago - Chile	Tel. +56 2 75770-00 Fax +56 2 75770-01 www.sew-eurodrive.cl ventas@sew-eurodrive.cl
China			
Production Assembly Sales Service	Tianjin	SEW-EURODRIVE (Tianjin) Co., Ltd. No. 46, 7th Avenue, TEDA Tianjin 300457	Tel. +86 22 25322612 Fax +86 22 25323273 info@sew-eurodrive.cn www.sew-eurodrive.com.cn
Assembly Sales Service	Suzhou	SEW-EURODRIVE (Suzhou) Co., Ltd. 333, Suhong Middle Road Suzhou Industrial Park Jiangsu Province, 215021	Tel. +86 512 62581781 Fax +86 512 62581783 suzhou@sew-eurodrive.cn
	Guangzhou	SEW-EURODRIVE (Guangzhou) Co., Ltd. No. 9, JunDa Road East Section of GETDD Guangzhou 510530	Tel. +86 20 82267890 Fax +86 20 82267922 guangzhou@sew-eurodrive.cn
	Shenyang	SEW-EURODRIVE (Shenyang) Co., Ltd. 10A-2, 6th Road Shenyang Economic Technological Development Area Shenyang, 110141	Tel. +86 24 25382538 Fax +86 24 25382580 shenyang@sew-eurodrive.cn
	Wuhan	SEW-EURODRIVE (Wuhan) Co., Ltd. 10A-2, 6th Road No. 59, the 4th Quanli Road, WEDA 430056 Wuhan	Tel. +86 27 84478388 Fax +86 27 84478389 wuhan@sew-eurodrive.cn
	Xi'An	SEW-EURODRIVE (Xi'An) Co., Ltd. No. 12 Jinye 2nd Road Xi'An High-Technology Industrial Development Zone Xi'An 710065	Tel. +86 29 68686262 Fax +86 29 68686311 xian@sew-eurodrive.cn

Colombia			
Assembly Sales Service (cont.)	Bogotá	SEW-EURODRIVE COLOMBIA LTDA. Calle 22 No. 132-60 Bodega 6, Manzana B Santafé de Bogotá	Tel. +57 1 54750-50 Fax +57 1 54750-44 www.sew-eurodrive.com.co sewcol@sew-eurodrive.com.co
Croatia			
Sales Service	Zagreb	KOMPEKS d. o. o. Zeleni dol 10 HR 10 000 Zagreb	Tel. +385 1 4613-158 Fax +385 1 4613-158 kompeks@inet.hr
Czech Republic			
Sales	Prague	SEW-EURODRIVE CZ S.R.O. Business Centrum Praha Lužná 591 CZ-16000 Praha 6 - Vokovice	Tel. +420 255 709 601 Fax +420 220 121 237 www.sew-eurodrive.cz sew@sew-eurodrive.cz
Assembly Service	Plzeň	SEW-EURODRIVE CZ S.R.O. Areal KRPA a.s. Zahradni 173/2 CZ-32600 Plzeň	Tel. +420 378 775 300 Fax +420 377 970 710
Denmark			
Assembly Sales Service	Copenhagen	SEW-EURODRIVEA/S Geminivej 28-30 DK-2670 Greve	Tel. +45 43 9585-00 Fax +45 43 9585-09 www.sew-eurodrive.dk sew@sew-eurodrive.dk
Egypt			
Sales Service	Cairo	Copam Egypt for Engineering & Agencies 33 El Hegaz ST, Heliopolis, Cairo	Tel. +20 2 22566-299 +1 23143088 Fax +20 2 22594-757 www.copam-egypt.com/ copam@datum.com.eg
Estonia			
Sales	Tallin	ALAS-KUUL AS Reti tee 4 EE-75301 Peetri küla, Rae vald, Harjumaa	Tel. +372 6593230 Fax +372 6593231 veiko.soots@alas-kuul.ee
Finland			
Assembly Sales Service	Lahti	SEW-EURODRIVE OY Vesimäentie 4 FIN-15860 Hollola 2	Tel. +358 201 589-300 Fax +358 3 780-6211 www.sew-eurodrive.fi sew@sew.fi
Production Assembly	Karkkila	SEW Industrial Gears Oy Valurinkatu 6, PL 8 FI-03600 Karkkila, 03601 Karkkila	Tel. +358 201 589-300 Fax +358 201 589-310 sew@sew.fi www.sew-eurodrive.fi
France			
Production Sales Service	Haguenau	SEW-USOCOME 48-54 route de Soufflenheim B. P. 20185 F-67506 Haguenau Cedex	Tel. +33 3 88 73 67 00 Fax +33 3 88 73 66 00 www.usocom.com sew@usocom.com

France			
Production	Forbach	SEW-USOCOME Zone industrielle Technopôle Forbach Sud B. P. 30269 F-57604 Forbach Cedex	Tel. +33 3 87 29 38 00
Assembly Sales Service	Bordeaux	SEW-USOCOME Parc d'activités de Magellan 62 avenue de Magellan - B. P. 182 F-33607 Pessac Cedex	Tel. +33 5 57 26 39 00 Fax +33 5 57 26 39 09
	Lyon	SEW-USOCOME Parc d'affaires Roosevelt Rue Jacques Tati F-69120 Vaulx en Velin	Tel. +33 4 72 15 37 00 Fax +33 4 72 15 37 15
	Nantes	SEW-USOCOME Parc d'activités de la forêt 4 rue des Fontenelles F-44140 Le Bignon	Tel. +33 2 40 78 42 00 Fax +33 2 40 78 42 20
	Paris	SEW-USOCOME Zone industrielle 2 rue Denis Papin F-77390 Verneuil l'Etang	Tel. +33 1 64 42 40 80 Fax +33 1 64 42 40 88

Gabon			
Sales	Libreville	ESG Electro Services Gabun Feu Rouge Lalala 1889 Libreville Gabun	Tel. +241 741059 Fax +241 741059 esg_services@yahoo.fr

Germany			
Headquarters Production Sales	Bruchsal	SEW-EURODRIVE GmbH & Co KG Ernst-Blickle-Straße 42 D-76646 Bruchsal P.O. Box Postfach 3023 • D-76642 Bruchsal	Tel. +49 7251 75-0 Fax +49 7251 75-1970 www.sew-eurodrive.de sew@sew-eurodrive.de
Production / Industrial Gears	Bruchsal	SEW-EURODRIVE GmbH & Co KG Christian-Pähr-Str.10 D-76646 Bruchsal	Tel. +49 7251 75-0 Fax +49 7251 75-2970
Production	Graben	SEW-EURODRIVE GmbH & Co KG Ernst-Blickle-Straße 1 D-76676 Graben-Neudorf P.O. Box Postfach 1220 • D-76671 Graben-Neudorf	Tel. +49 7251 75-0 Fax +49 7251 75-2970
	Östringen	SEW-EURODRIVE Östringen GmbH Franz-Gurk-Straße 2 D-76684 Östringen P.O. Box Postfach 1174 • D-76677 Östringen	Tel. +49 7253 92540 Fax +49 7253 925490 oestringen@sew-eurodrive.de
Service Competence Center	Central	SEW-EURODRIVE GmbH & Co KG Ernst-Blickle-Straße 1 D-76676 Graben-Neudorf	Tel. +49 7251 75-1710 Fax +49 7251 75-1711 sc-mitte@sew-eurodrive.de

Germany			
Service Competence Center (cont.)	North	SEW-EURODRIVE GmbH & Co KG Alte Ricklinger Straße 40-42 D-30823 Garbsen (near Hannover)	Tel. +49 5137 8798-30 Fax +49 5137 8798-55 sc-nord@sew-eurodrive.de
	East	SEW-EURODRIVE GmbH & Co KG Dankritzer Weg 1 D-08393 Meerane (near Zwickau)	Tel. +49 3764 7606-0 Fax +49 3764 7606-30 sc-ost@sew-eurodrive.de
	South	SEW-EURODRIVE GmbH & Co KG Domagkstraße 5 D-85551 Kirchheim (near München)	Tel. +49 89 909552-10 Fax +49 89 909552-50 sc-sued@sew-eurodrive.de
	West	SEW-EURODRIVE GmbH & Co KG Siemensstraße 1 D-40764 Langenfeld (near Düsseldorf)	Tel. +49 2173 8507-30 Fax +49 2173 8507-55 sc-west@sew-eurodrive.de
	Electronics	SEW-EURODRIVE GmbH & Co KG Ernst-Blickle-Straße 42 D-76646 Bruchsal	Tel. +49 7251 75-1780 Fax +49 7251 75-1769 sc-elektronik@sew-eurodrive.de
	Drive Service Hotline / 24 Hour Service		+49 180 5 SEWHELP +49 180 5 7394357 14 euro cents/min on the German landline network. Max 42 euro cents/min from a German mobile network. Prices for mobile and international calls may differ.
	Great Britain		
Assembly Sales Service	Normanton	SEW-EURODRIVE Ltd. Beckbridge Industrial Estate Normanton West Yorkshire WF6 1QR	Tel. +44 1924 893-855 Fax +44 1924 893-702 www.sew-eurodrive.co.uk info@sew-eurodrive.co.uk
	Drive Service Hotline / 24 Hour Service		Tel. 01924 896911
Service Competence Center	Southern England	SEW-EURODRIVE Ltd. Unit 41 Easter Park Benyon Road Silchester Reading Berkshire RG7 2PQ	Tel. +44 1189 701-699 Fax +44 1189 701-021
Greece			
Sales	Athens	Christ. Boznos & Son S.A. 12, K. Mavromichali Street P.O. Box 80136 GR-18545 Piraeus	Tel. +30 2 1042 251-34 Fax +30 2 1042 251-59 www.boznos.gr info@boznos.gr
Hong Kong			
Assembly Sales Service	Hong Kong	SEW-EURODRIVE LTD. Unit No. 801-806, 8th Floor Hong Leong Industrial Complex No. 4, Wang Kwong Road Kowloon, Hong Kong	Tel. +852 36902200 Fax +852 36902211 contact@sew-eurodrive.hk

Hungary			
Sales Service	Budapest	SEW-EURODRIVE Kft. H-1037 Budapest Kunigunda u. 18	Tel. +36 1 437 06-58 Fax +36 1 437 06-50 office@sew-eurodrive.hu
Iceland			
Sales	Reykjavik	VARMA & VELAVERK EHF Dalshrauni 5 IS-220 Hafnarjördur	Tel. +354 585 1070 Fax +354 585)1071 varmaverk@varmaverk.is www.varmaverk.is
India			
Registered Office Assembly Sales Service	Vadodara	SEW-EURODRIVE India Private Limited Plot No. 4, GIDC POR Ramangamdi • Vadodara - 391 243 Gujarat	Tel. +91 265 3045200, +91 265 2831086 Fax +91 265 3045300, +91 265 2831087 www.seweurodriveindia.com salesvadodara@seweurodriveindia.com
Assembly Sales Service	Chennai	SEW-EURODRIVE India Private Limited Plot No. K3/1, Sipcot Industrial Park Phase II Mambakkam Village Sriperumbudur - 602105 Kancheepuram Dist, Tamil Nadu	Tel. +91 44 37188888 Fax +91 44 37188811 saleschennai@seweurodriveindia.com
Indonesia			
Sales	Jakarta	PT. Cahaya Sukses Abadi Komplek Rukan Puri Mutiara Blok A no 99, Sunter Jakarta 14350	Tel: +62 21 65310599 Fax: +62 21 65310600 csajkt@cbn.net.id
		PT. Agrindo Putra Lestari Jl.Prof.DR.Latumenten no27/A Jakarta 11330	Tel: +62 21 63855588 Fax: +62 21 63853789 aplindo@indosat.net.id
		PT. Sentratek Adiprestasi Jl. Industri Raya I, Komp. Gunung Sahari 8 Block B-3 Gunung Sahari Utara, Sawah B Jakarta 10720	Tel: +62 21 6398122 Fax: +62 21 6499264 adm_samit@yahoo.co.id roberto_samit@yahoo.co.id
	Medan	PT. Serumpun Indah Lestari Pulau Solor no. 8, Kawasan Industri Medan II Medan 20252	Tel. +62 61 687 1221 Fax +62 61 6871429 / +62 61 6871458 / +62 61 30008041 sil@serumpunindah.com serumpunindah@yahoo.com
	Surabaya	PT. TRIAGRI JAYA ABADI Jl. Sukosemolo No. 63, Galaxi Bumi Permai G6 No. 11 Surabaya 60122	Tel: +62 31 5990128 Fax: +62 31 5962666 triagri@indosat.net.id
		CV. Multi Mas Jl. Raden Saleh 43A Kav. 18 Surabaya 60174	Tel: +62 31 5458589 / +62 31 5317224 Fax: +62 31 5317220 / +62 31 5994629 sianhwa@sby.centrin.net.id
Ireland			
Sales Service	Dublin	Alperton Engineering Ltd. 48 Moyle Road Dublin Industrial Estate Glasnevin, Dublin 11	Tel. +353 1 830-6277 Fax +353 1 830-6458 info@alperton.ie www.alperton.ie

Israel			
Sales	Tel-Aviv	Liraz Handasa Ltd. Ahofer Str 34B / 228 58858 Holon	Tel. +972 3 5599511 Fax +972 3 5599512 www.liraz-handasa.co.il office@liraz-handasa.co.il
Italy			
Assembly Sales Service	Solaro	SEW-EURODRIVE di R. Blicke & Co.s.a.s. Via Bernini,14 I-20020 Solaro (Milano)	Tel. +39 02 96 9801 Fax +39 02 96 799781 www.sew-eurodrive.it sewit@sew-eurodrive.it
Ivory Coast			
Sales	Abidjan	SICA Société industrielle & commerciale pour l'Afrique 165, Boulevard de Marseille 26 BP 1115 Abidjan 26	Tel. +225 21 25 79 44 Fax +225 21 25 88 28 sicamot@aviso.ci
Japan			
Assembly Sales Service	Iwata	SEW-EURODRIVE JAPAN CO., LTD 250-1, Shimoman-no, Iwata Shizuoka 438-0818	Tel. +81 538 373811 Fax +81 538 373855 www.sew-eurodrive.co.jp sewjapan@sew-eurodrive.co.jp
Kazakhstan			
Sales	Almaty	ТОО "СЕВ-ЕВРОДРАЙВ" пр.Райымбека, 348 050061 г. Алматы Республика Казахстан	Тел. +7 (727) 334 1880 Факс +7 (727) 334 1881 www.sew-eurodrive.kz sew@sew-eurodrive.kz
Latvia			
Sales	Riga	SIA Alas-Kuul Katlakalna 11C LV-1073 Riga	Tel. +371 6 7139253 Fax +371 6 7139386 www.alas-kuul.com info@alas-kuul.com
Lebanon			
Sales	Beirut	Gabriel Acar & Fils sarl B. P. 80484 Bourj Hammoud, Beirut	Tel. +961 1 510 532 Fax +961 1 494 971 ssacar@inco.com.lb
Jordan Kuwait Saudi Arabia Syria	Beirut	Middle East Drives S.A.L. (offshore) Sin El Fil. B. P. 55-378 Beirut	Tel. +961 1 494 786 Fax +961 1 494 971 info@medrives.com www.medrives.com
Lithuania			
Sales	Alytus	UAB Irseva Statybininku 106C LT-63431 Alytus	Tel. +370 315 79204 Fax +370 315 56175 info@irseva.lt www.sew-eurodrive.lt

Luxembourg			
Assembly Sales Service	Brussels	SEW Caron-Vector Research park Haasrode Evenementenlaan 7 BE-3001 Leuven	Tel. +32 16 386-311 Fax +32 16 386-336 www.sew-eurodrive.be info@sew-eurodrive.be
Malaysia			
Assembly Sales Service	Johore	SEW-EURODRIVE SDN BHD No. 95, Jalan Seroja 39, Taman Johor Jaya 81000 Johor Bahru, Johor West Malaysia	Tel. +60 7 3549409 Fax +60 7 3541404 sales@sew-eurodrive.com.my
Mauritania			
Sales	Zouérate	AFRICOM - SARL En Face Marché Dumez P.B. 88 Zouérate	Tel. +222 45 44 50 19 Fax +222 45 44 03 14 contact@africom-sarl.com
Mexico			
Assembly Sales Service	Quéretaro	SEW-EURODRIVE MEXICO SA DE CV SEM-981118-M93 Tequisquiapan No. 102 Parque Industrial Quéretaro C.P. 76220 Quéretaro, México	Tel. +52 442 1030-300 Fax +52 442 1030-301 www.sew-eurodrive.com.mx scmexico@sew-eurodrive.com.mx
Morocco			
Sales	Casablanca	Afit Route D'El Jadida KM 14 RP8 Province de Nouaceur Commune Rurale de Bouskoura MA 20300 Casablanca	Tel. +212 522633700 Fax +212 522621588 fatima.haqui@premium.net.ma www.groupe-premium.com
Netherlands			
Assembly Sales Service	Rotterdam	VECTOR Aandrijftechniek B.V. Industrieweg 175 NL-3044 AS Rotterdam Postbus 10085 NL-3004 AB Rotterdam	Tel. +31 10 4463-700 Fax +31 10 4155-552 www.sew-eurodrive.nl info@sew-eurodrive.nl
New Zealand			
Assembly Sales Service	Auckland	SEW-EURODRIVE NEW ZEALAND LTD. P.O. Box 58-428 82 Greenmount drive East Tamaki Auckland	Tel. +64 9 2745627 Fax +64 9 2740165 www.sew-eurodrive.co.nz sales@sew-eurodrive.co.nz
	Christchurch	SEW-EURODRIVE NEW ZEALAND LTD. 10 Settlers Crescent, Ferrymead Christchurch	Tel. +64 3 384-6251 Fax +64 3 384-6455 sales@sew-eurodrive.co.nz

Norway			
Assembly Sales Service	Moss	SEW-EURODRIVE A/S Solgaard skog 71 N-1599 Moss	Tel. +47 69 24 10 20 Fax +47 69 24 10 40 www.sew-eurodrive.no sew@sew-eurodrive.no
Pakistan			
Sales	Karachi	Industrial Power Drives Al-Fatah Chamber A/3, 1st Floor Central Commercial Area, Sultan Ahmed Shah Road, Block 7/8, Karachi	Tel. +92 21 452 9369 Fax +92-21-454 7365 seweurodrive@cyber.net.pk
Peru			
Assembly Sales Service	Lima	SEW DEL PERU MOTORES REDUCTORES S.A.C. Los Calderos, 120-124 Urbanizacion Industrial Vulcano, ATE, Lima	Tel. +51 1 3495280 Fax +51 1 3493002 www.sew-eurodrive.com.pe sewperu@sew-eurodrive.com.pe
Philippines			
Sales	Luzon	Totaltech Corporation 5081-B C&L Mansion Filmore Ave. Cor. Fahrenheit St. 1235 Makati City	Tel: +63 2 551-9265 / +63 2 551-9271 / +63 2 551-9378 Fax: +63 2 551-9273 totaltek@info.com.ph
	All Areas	P.T. Cerna Corporation 2166 Primo Rivera St., Brgy. La Paz, Makati City	Tel: +63 2 890 2862 / +63 2 890 2813 Fax: +63 2 890 2802 electrical_controls@ptcerna.com
Poland			
Assembly Sales Service	Lodz	SEW-EURODRIVE Polska Sp.z.o.o. ul. Techniczna 5 PL-92-518 Łódź	Tel. +48 42 676 53 00 Fax +48 42 676 53 45 www.sew-eurodrive.pl sew@sew-eurodrive.pl
	24 Hour Service		Tel. +48 602 739 739 (+48 602 SEW SEW) serwis@sew-eurodrive.pl
Portugal			
Assembly Sales Service	Coimbra	SEW-EURODRIVE, LDA. Apartado 15 P-3050-901 Mealhada	Tel. +351 231 20 9670 Fax +351 231 20 3685 www.sew-eurodrive.pt infosew@sew-eurodrive.pt
Service Competence Center	Lisboa	SEW-EURODRIVE, LDA. Núcleo Empresarial I de São Julião do Tojal Rua de Entremuros, 54 Fracção I P-2660-533 São Julião do Tojal	Tel. +351 21 958-0198 Fax +351 21 958-0245 esc.lisboa@sew-eurodrive.pt
Romania			
Sales Service	Bucharest	Sialco Trading SRL str. Madrid nr.4 011785 Bucuresti	Tel. +40 21 230-1328 Fax +40 21 230-7170 sialco@sialco.ro

Russia			
Assembly Sales Service	St. Petersburg	ZAO SEW-EURODRIVE P.O. Box 36 195220 St. Petersburg Russia	Tel. +7 812 3332522 +7 812 5357142 Fax +7 812 3332523 www.sew-eurodrive.ru sew@sew-eurodrive.ru
Senegal			
Sales	Dakar	SENEMECA Mécanique Générale Km 8, Route de Rufisque B.P. 3251, Dakar	Tel. +221 338 494 770 Fax +221 338 494 771 senemeca@sentoosn www.senemeca.com
Serbia			
Sales	Beograd	DIPAR d.o.o. Ustanicka 128a PC Košum, IV floor SCG-11000 Beograd	Tel. +381 11 347 3244 / +381 11 288 0393 Fax +381 11 347 1337 office@dipar.rs
Singapore			
Assembly Sales Service	Singapore	SEW-EURODRIVE PTE. LTD. No 9, Tuas Drive 2 Jurong Industrial Estate Singapore 638644	Tel. +65 68621701 Fax +65 68612827 www.sew-eurodrive.com.sg sewsingapore@sew-eurodrive.com
Slovakia			
Sales	Bratislava	SEW-Eurodrive SK s.r.o. Rybničná 40 SK-831 06 Bratislava	Tel. +421 2 33595 202 Fax +421 2 33595 200 sew@sew-eurodrive.sk www.sew-eurodrive.sk
	Žilina	SEW-Eurodrive SK s.r.o. Industry Park - PChZ ulica M.R.Štefánika 71 SK-010 01 Žilina	Tel. +421 41 700 2513 Fax +421 41 700 2514 sew@sew-eurodrive.sk
	Banská Bystrica	SEW-Eurodrive SK s.r.o. Rudlovska cesta 85 SK-974 11 Banská Bystrica	Tel. +421 48 414 6564 Fax +421 48 414 6566 sew@sew-eurodrive.sk
	Košice	SEW-Eurodrive SK s.r.o. Slovenská ulica 26 SK-040 01 Košice	Tel. +421 55 671 2245 Fax +421 55 671 2254 sew@sew-eurodrive.sk
Slovenia			
Sales Service	Celje	Pakman - Pogonska Tehnika d.o.o. Ul. XIV. divizije 14 SLO - 3000 Celje	Tel. +386 3 490 83-20 Fax +386 3 490 83-21 pakman@siol.net
South Africa			
Assembly Sales Service	Johannesburg	SEW-EURODRIVE (PROPRIETARY) LIMITED Eurodrive House Cnr. Adcock Ingram and Aerodrome Roads Aeroton Ext. 2 Johannesburg 2013 P.O.Box 90004 Bertsham 2013	Tel. +27 11 248-7000 Fax +27 11 494-3104 www.sew.co.za info@sew.co.za

South Africa			
	Cape Town	SEW-EURODRIVE (PROPRIETARY) LIMITED Rainbow Park Cnr. Racecourse & Omuramba Road Montague Gardens Cape Town P.O.Box 36556 Chempet 7442 Cape Town	Tel. +27 21 552-9820 Fax +27 21 552-9830 Telex 576 062 cfoster@sew.co.za
	Durban	SEW-EURODRIVE (PROPRIETARY) LIMITED 2 Monaco Place Pinetown Durban P.O. Box 10433, Ashwood 3605	Tel. +27 31 700-3451 Fax +27 31 700-3847 cdejager@sew.co.za
	Nelspruit	SEW-EURODRIVE (PTY) LTD. 7 Christie Crescent Vintonia P.O.Box 1942 Nelspruit 1200	Tel. +27 13 752-8007 Fax +27 13 752-8008 robermeyer@sew.co.za
South Korea			
Assembly Sales Service	Ansan-City	SEW-EURODRIVE KOREA CO., LTD. B 601-4, Banweol Industrial Estate 1048-4, Shingil-Dong Ansan 425-120	Tel. +82 31 492-8051 Fax +82 31 492-8056 www.sew-korea.co.kr master.korea@sew-eurodrive.com
	Busan	SEW-EURODRIVE KOREA Co., Ltd. No. 1720 - 11, Songjeong - dong Gangseo-ku Busan 618-270	Tel. +82 51 832-0204 Fax +82 51 832-0230 master@sew-korea.co.kr
Spain			
Assembly Sales Service	Bilbao	SEW-EURODRIVE ESPAÑA, S.L. Parque Tecnológico, Edificio, 302 E-48170 Zamudio (Vizcaya)	Tel. +34 94 43184-70 Fax +34 94 43184-71 www.sew-eurodrive.es sew.spain@sew-eurodrive.es
Sri Lanka			
Sales	Colombo	SM International (Pte) Ltd 254, Galle Raod Colombo 4, Sri Lanka	Tel. +94 1 2584887 Fax +94 1 2582981
Sweden			
Assembly Sales Service	Jönköping	SEW-EURODRIVE AB Gnejsvägen 6-8 S-55303 Jönköping Box 3100 S-55003 Jönköping	Tel. +46 36 3442 00 Fax +46 36 3442 80 www.sew-eurodrive.se jonkoping@sew.se
Sales	Göteborg	SEW-EURODRIVE AB Gustaf Werners gata 8 S-42132 Västra Frölunda	Tel. +46 31 70968 80 Fax +46 31 70968 93 goteborg@sew.se
	Stockholm	SEW-EURODRIVE AB Björkholmsvägen 10 S-14146 Huddinge	Tel. +46 8 44986 80 Fax +46 8 44986 93 stockholm@sew.se

Sweden			
Sales (cont.)	Malmö	SEW-EURODRIVE AB Borrgatan 5 S-21124 Malmö	Tel. +46 40 68064 80 Fax +46 40 68064 93 malmo@sew.se
	Skellefteå	SEW-EURODRIVE AB Trädgårdsgatan 8 S-93131 Skellefteå	Tel. +46 910 7153 80 Fax +46 910 7153 93 skelleftea@sew.se
Switzerland			
Assembly Sales Service	Basel	Alfred Imhof A.G. Jurastrasse 10 CH-4142 Münchenstein bei Basel	Tel. +41 61 417 1717 Fax +41 61 417 1700 www.imhof-sew.ch info@imhof-sew.ch
Taiwan (R.O.C.)			
Sales	Nan Tou	Ting Shou Trading Co., Ltd. No. 55 Kung Yeh N. Road Industrial District Nan Tou 540	Tel. +886 49 255353 Fax +886 49 257878
	Taipei	Ting Shou Trading Co., Ltd. 6F-3, No. 267, Sec. 2 Tung Hwa South Road, Taipei	Tel. +886 2 27383535 Fax +886 2 27368268 Telex 27 245 sewtwn@ms63.hinet.net
Thailand			
Assembly Sales Service	Chonburi	SEW-EURODRIVE (Thailand) Ltd. 700/456, Moo.7, Donhuaroh Muang Chonburi 20000	Tel. +66 38 454281 Fax +66 38 454288 sewthailand@sew-eurodrive.com
Tunisia			
Sales	Tunis	T. M.S. Technic Marketing Service Zone Industrielle Mghira 2 Lot No. 39 2082 Fouchana	Tel. +216 79 40 88 77 Fax +216 79 40 88 66 www.tms.com.tn tms@tms.com.tn
Turkey			
Assembly Sales Service	Istanbul	SEW-EURODRIVE Hareket Sistemleri San. ve Tic. Ltd. Sti. Bagdat Cad. Koruma Cikmazi No. 3 TR-34846 Maltepe ISTANBUL	Tel. +90 216 4419163 / 4419164 Fax +90 216 3055867 www.sew-eurodrive.com.tr sew@sew-eurodrive.com.tr
Ukraine			
Sales Service	Dnepropetrovsk	SEW-EURODRIVE Str. Rabochaja 23-B, Office 409 49008 Dnepropetrovsk	Tel. +380 56 370 3211 Fax +380 56 372 2078 www.sew-eurodrive.ua sew@sew-eurodrive.ua
Sales	Kiev	SEW-EURODRIVE GmbH S. Oleynika str. 21 02068 Kiev	Tel. +380 44 503 95 77 Fax +380 44 503 95 78 kso@sew-eurodrive.ua
	Donetsk	SEW-EURODRIVE GmbH 25th anniversary of RKKA av. 1-B, of. 805 Donetsk 83000	Tel. +380 62 38 80 545 Fax +380 62 38 80 533 dso@sew-eurodrive.ua

United Arab Emirates			
Sales Service	Sharjah	Copam Middle East (FZC) Sharjah Airport International Free Zone P.O. Box 120709 Sharjah	Tel. +971 6 5578-488 Fax +971 6 5578-499 copam_me@eim.ae
Uruguay			
Sales	Montevideo	SEW-EURODRIVE Uruguay, S. A. Jose Serrato 3569 Esquina Corumbe CP 12000 Montevideo	Tel. +598 2 21181-89 Fax +598 2 21181-89 sewuy@sew-eurodrive.com.uy
Venezuela			
Assembly Sales Service	Valencia	SEW-EURODRIVE Venezuela S.A. Av. Norte Sur No. 3, Galpon 84-319 Zona Industrial Municipal Norte Valencia, Estado Carabobo	Tel. +58 241 832-9804 Fax +58 241 838-6275 www.sew-eurodrive.com.ve ventas@sew-eurodrive.com.ve sewfinanzas@cantv.net
Vietnam			
Sales	Ho Chi Minh City	All sectors except for ports, mining and offshore: Nam Trung Co., Ltd 250 Binh Duong Avenue, Thu Dau Mot Town, Binh Duong Province HCM office: 91 Tran Minh Quyen Street District 10, Ho Chi Minh City	Tel. +84 8 8301026 Fax +84 8 8392223 namtrungco@hcm.vnn.vn truongtantam@namtrung.com.vn khanh-nguyen@namtrung.com.vn
		Ports, mining and offshore: DUC VIET INT LTD Industrial Trading and Engineering Services A75/6B/12 Bach Dang Street, Ward 02, Tan Binh District, 70000 Ho Chi Minh City	Tel. +84 8 62969 609 Fax +84 8 62938 842 totien@ducvietint.com
	Hanoi	Nam Trung Co., Ltd R.205B Tung Duc Building 22 Lang ha Street Dong Da District, Hanoi City	Tel. +84 4 37730342 Fax +84 4 37762445 namtrunghn@hn.vnn.vn

14 Abbreviation Key

For a detailed list of abbreviations and variables used, refer to chapter 4 "Project Planning Information", page 41.

15 Index

A

AD dimensions	267, 402, 566, 649, 705
AD selection process	60
Altitude	12
AM Adapter - IEC	263, 398, 562, 646, 704
Ambient temperature	11
AR Torque limiting coupling	57
Axial forces	51

B

Backdriving efficiency	44
Backstop torques and lift-off speeds	56, 60
Bolts	124

C

Calculations, PT Pilot®	42
Covers, fixed for hollow shaft	129

D

Dimensions, notes and explanations	131
Direction of rotation	16
DUO - oil aging monitor	67

E

Efficiencies	
Backdriving	44
General	44
Helical-worm (S-series)	654
Extended storage	15
Eyebolts	124

F

FKM seals	70
Flange dimension details	
FAF., KAF., SAF.. and WAF..	128
FF., KF., SF.. and WF..	127
RF.. and R..F	126
Flange mounting	112
Foot mounting	112

G

Greases	103
---------------	-----

H

Hollow shaft with key	
Recommended design	119
Removal kits	121
Standard design	115
Hollow shaft, chamfers	130
Hydraulic centrifugal coupling	23
Hypoid gear units	13

I

Inertia	46
Inertia acceleration factor	46
Input assembly types	39

L

Location, shaft and flange	16
Lubrication	103
Fill quantities	106
Greases	103
Table of lubricants	104
Table symbols	103

M

Mechanical ratings, S-series	652
Mounting positions	18, 69
F-series	77
K-series	80
R-series	72
SPIROPLAN® W-series	99
S-series	93

N

Nameplate information	19
NOCO fluid	14
Noise level	12
Nomenclature	25

O

Oil	
DUO diagnostic monitor	67
Fill quantities	106
Table of lubricants	104
Options, nomenclature	26
Options, shaft and flange	
F-series	31
K-series	33
R-series	30
S-series	35
W-SPIROPLAN®	37
Ordering information	16
OS surface protection	14
Output shaft sizes	
Hollow	411, 575, 684, 710
Solid	274, 409, 573, 682, 708
Overhung load	51

P

Paint	12
Positions	
Hollow shaft entry	17
Mounting	18
Solid shaft and flange positions	16
Torque arm	17
PT Pilot®	11, 42, 70

R

Reduced backlash	12, 125
Removing customer shaft	123
Removal kits	121
RM extended bearing housing selection	64
Rotation, direction of output shaft	16
Run-in phase	45

S

Self-locking gears	44
Service factor	46
Shaft and flange combinations	
F-series	31
K-series	33
R-series	30

S

S-series	35
W-SPIROPLAN®	37
Shaft entry	17
Shaft positions	16
Shaft sizes, AD input	267, 402, 566, 649, 705
Shaft sizes, output	
Hollow	411, 575, 684, 710
Solid	274, 409, 573, 682, 708
Shock load	46
Speed Monitor, W	58
SPIROPLAN®	13, 44
Storage conditions	15
Surface protection	14
Swing base	23

T

Temperature, ambient	11
Thermal losses	45, 70
Tolerances	111
TorqLOC®	113
Torque arm	
Part numbers	112
Positions	17

V

Variables, list of application	41
--------------------------------------	----

W

Weights	
AD	136
AM	135

SEW-EURODRIVE, Inc. (USA)
Terms and Conditions of Sale

1. GENERAL

All orders for products and drawings furnished in connection therewith (hereinafter collectively called "products") manufactured or supplied by SEWEurodrive, Inc. ("Eurodrive"), shall be subject to these terms and conditions of sale. No modifications or additions hereto will be binding unless agreed to in writing by an authorized officer of Eurodrive.

2. QUOTATIONS

Price quotations by Eurodrive are subject to change without notice. All products sold are subject to price in effect at time of shipment.

3. TAXES

Prices do not include Sales, Use, Excise, or other taxes payable to any governmental authority in respect of the sale of Eurodrive's products. The purchaser shall pay the amount of any such taxes or shall reimburse Eurodrive for the amount thereof that Eurodrive may be required to pay.

4. PAYMENTS

Unless otherwise provided, terms of payment are 30 days net from date of invoice for purchasers whose credit is approved. Eurodrive reserves the right to charge interest on any balance outstanding at 2% per month (or fraction thereof) or as Eurodrive shall determine, up to the maximum rate allowed by law, from the date payment is due to the date payment is actually received. Pro rata payments shall become due as shipments are made. If shipments are delayed by or at the request of the purchaser, payment shall become due when Eurodrive is prepared to make shipment. If the cost to Eurodrive of products is increased by reason of delays caused by the purchaser, such additional cost incurred by Eurodrive shall be paid by the purchaser. Eurodrive may, if it deems itself insecure by reason of the financial condition of purchaser or otherwise, require full or partial payment in advance and as a condition to the continuance of production or shipment on the terms specified herein.

5. ACCEPTANCE

No order or other offer shall be binding upon Eurodrive until accepted in writing by an authorized officer of Eurodrive.

6. CHANGES

Eurodrive will not accept changes in specification unless such changes are requested in writing and agreed to in writing by an authorized officer of Eurodrive and the purchaser agrees to pay, if necessary, in addition to the original purchase price a sum so set by Eurodrive.

7. CANCELLATION

Any order when placed with and accepted by Eurodrive is not subject to cancellation unless agreed to in writing by an authorized officer of Eurodrive. Cancellations are subject to reasonable charges based upon expenses already incurred and commitments made by Eurodrive.

8. DELIVERY

Any indicated dates of delivery are approximate only, but Eurodrive will attempt to meet them where possible. Eurodrive shall not be liable for delays in manufacturing or delivery or failure to manufacture or deliver due to any event in the nature of force majeure or any cause beyond Eurodrive's reasonable control. Eurodrive will not be bound by any penalty clause contained in any specification or order submitted by the purchaser unless such clause is agreed to in writing by an authorized officer of Eurodrive. Delivery of products shall be made FOB Eurodrive's factory unless otherwise agreed to in writing by authorized officer of Eurodrive.

9. PATENTS

Eurodrive shall indemnify and hold harmless the purchaser against all claims or actions that are instituted against the purchaser on the grounds that the purchaser has infringed the patent rights of others by using, reselling, or promoting the sale or resale of Eurodrive's products, provided that Eurodrive shall not be obligated hereunder if:

- a) The purchaser fails to give Eurodrive prompt notice of any such claim or actions, or
- b) Such claims or actions against the purchaser are based wholly or in part on the existence or operation of any complete installation or apparatus incorporating Eurodrive's products as components and which is designed or manufactured by the purchaser or its customers.

10. REGULATORY LAWS OR STANDARDS

Eurodrive makes no representation that its products conform to state or local laws, ordinances, regulations, codes or standards except as may be otherwise agreed to in writing by an authorized officer of Eurodrive.

11. LIMITED WARRANTY

Eurodrive warrants all its products against defects in material and workmanship for a period of one (1) year from the date the product is placed in service to a maximum of eighteen (18) months from date of shipment. Parts subject to replacement due to operational wear and tear, viz. Varigear belts and Varimot traction elements, are not covered by this Limited Warranty. Notwithstanding the foregoing, any equipment or components of the products not of Eurodrive's own manufacture and/or specified by the

purchaser is sold under only such warranty as the maker thereof gives Eurodrive and Eurodrive is able to enforce, but such items are not warranted by Eurodrive in any way. Use of products above rated capacity, misuse, field alterations of products, damage due to lack of maintenance or improper storage, neglect or accident are also excluded from this Limited Warranty.

This Limited Warranty is effective provided:

- a) The purchaser notifies Eurodrive in writing of the alleged defect immediately after it becomes known to the purchaser; and
- b) no alterations, repairs, or services have been performed by the purchaser or third parties on the products without written approval of an authorized officer of Eurodrive.

Eurodrive's obligation under this Limited Warranty is limited to the repair or replacement FOB Eurodrive's factory or any part or parts found to be defective in material or workmanship.

Eurodrive shall, in no event, be liable to the user/purchaser under this Limited Warranty, or otherwise, for claims, expenditures or losses arising from operational delays or work stoppages or damages to property or people caused by defective products or for consequential or indirect damage of any nature whatsoever.

THIS LIMITED WARRANTY IS IN LIEU OF ALL OTHER EXPRESS OR IMPLIED WARRANTIES INCLUDING ANY WARRANTY OF MERCHANTABILITY OR FITNESS FOR ANY PARTICULAR PURPOSE.

12. ASSIGNMENT

No contract to purchase goods from Eurodrive may be assigned by the purchaser without prior agreement in writing by an authorized officer of Eurodrive.

13. SECURITY INTEREST

Unless and until the products are fully paid for, Eurodrive reserves a security interest in them to secure the unpaid balance of the price and all other obligations of the purchaser to Eurodrive however arising. The purchaser hereby grants Eurodrive a power of attorney to execute and file on behalf of purchaser all necessary financing statements and other similar documents required to protect the security interest granted herein.

14. DAMAGES; LIMITATION

In the event of breach of this agreement by Eurodrive, the rights of the purchaser are limited to the amount therefore paid to Eurodrive for the goods. THE PURCHASER SHALL HAVE NO RIGHT TO CONSEQUENTIAL OR INDIRECT DAMAGES, WHETHER FOR INJURES TO PERSON, PROPERTY OR OTHERWISE.

15. DEFAULT

If the purchaser defaults in performing any of its obligations to Eurodrive under this agreement, or any other agreements, Eurodrive may, at its option and without incurring any liability thereby, elect to terminate this agreement or to terminate any or all other agreements with the purchaser or to terminate this agreement together with any or all such other agreements. Furthermore, Eurodrive shall have a right to all damages sustained, including loss of profits.

16. INSOLVENCY

If the purchaser shall be insolvent or cease doing business or be the subject of any proceedings under any bankruptcy, insolvency, reorganization or arrangement statute or law, such act shall at the option of Eurodrive, be deemed a default under this agreement, and Eurodrive may elect to cease performing and cancel this agreement with respect to any products not delivered or received prior to the election. All of the foregoing shall be without prejudice to recovery by Eurodrive of damages for work performed and for loss of profits and material and products delivered.

17. CONFIDENTIALITY

Only officers of SEW Eurodrive have the authority to sign confidentiality agreements.

18. MISCELLANEOUS

The provisions of this agreement shall be governed and construed in accordance with the laws of the State of South Carolina. These terms and conditions set forth the entire understanding and agreement of the parties hereto in respect to the subject matter hereof, and all prior undertakings between the parties hereto, together with all representations and obligations of such parties in respect to such subject matter, shall be superseded by and merged into this agreement. No provisions hereof shall be waived, changed, terminated, modified, discharged or rescinded, orally or otherwise, except by a writing signed by the party to be charged by any such waiver, change, termination, modification, discharge, or rescission. No waiver of any breach of any provision of this agreement shall constitute an amendment or modification of this agreement, or any provision thereof. If any provision of this agreement shall be held to be unenforceable or inapplicable in any way or respect, such holding shall not affect the enforceability of any other provision of this agreement under any other circumstances. The provisions of this agreement shall bind and inure to the benefits of the parties hereto and their respective heirs, executors, administrators, successors, and (subject to any restrictions on assignment hereinabove set forth) assigns. In the event unspecified redress or commitments develop not covered above, terms of the Uniform Commercial Code under the laws of South Carolina will be construed as being effective as they may pertain.

SEW-EURODRIVE COMPANY OF CANADA LTD. Terms and Conditions of Sale

1. GENERAL

All orders for the equipment (hereinafter called "Equipment") manufactured or supplied by the Vendor, including any supplementary services, advice or assistance provided in relation to such equipment, shall be subject to these warranties, terms and conditions of sale. No modifications or additional warranties, terms or conditions will be binding on the Vendor unless agreed to in writing and signed by an authorized officer of the Vendor. Any purchase order provided by the Purchaser is solely for the convenience of the Purchaser and in no way alters or supercedes the provision of the warranties, terms and conditions of the sale as stated herein which shall have priority and shall govern this transaction.

2. QUOTATIONS

Notwithstanding the retention of title by the Vendor, price quotations by the Vendor are subject to change without notice, are not effective unless signed by an authorized officer of the Vendor and expire 30 days from their date. Further, quotations are based on data provided to the Vendor by the Purchaser, and the Vendor shall have no liability to the Purchaser if the data provided to the Vendor is incorrect or incomplete. Finally, orders accepted by the Vendor for equipment to be manufactured outside of Canada, are accepted at prices based on the currency exchange rate and customs duty rate in effect on the day of acceptance of the order. Should there be a change in any one of these rates of more than +1/1% prior to full payment of Vendor's invoice to Purchaser, the selling price will be adjusted accordingly.

3. TAXES

The Vendor's prices do not include sales, use, excise, or other taxes payable to any government authority in respect of the sale of the Vendor's equipment. The Purchaser shall pay, in addition to the Vendor's price, the amount of any such taxes or shall reimburse the Vendor for the amount thereof that the Vendor may be required to pay. Without limiting the generality of the foregoing, taxes shall include (a) all applicable sales, use or other taxes (notwithstanding their designation as sales tax, goods and services tax, harmonized sales tax and other taxes imposed by any governmental body upon the transaction described herein, unless the Purchaser provides the Vendor with satisfactory evidence of exemption acceptable to the taxing authorities; (b) all additional costs arising from any duties and any federal, provincial or local laws imposed as processing or any other taxes on the raw materials or manufactured product for which Vendor may be liable; and (c) all additional costs arising from any federal, provincial or local laws fixing or regulating hours and/or costs of labor producing the equipment described herein.

4. PAYMENTS

Unless otherwise provided, terms of payment are 30 days net from the Delivery time, as defined hereinafter, for Purchasers whose credit is acceptable to the Vendor. The Vendor reserves the right to charge interest on any balance outstanding, at the rate of two percent (2%) per month from the date payment is due to the date that payment is actually received. Where such balance is payable in installments, the Vendor reserves the right to charge interest on overdue installments at the said rate from the date payment is due to the date of payment. Pro rata payments shall become due as shipments are made and actually received. If shipments are delayed by or at the request of the Purchaser, payment shall become due when the Vendor is prepared to make shipment. If the cost to the Vendor of equipment is increased by reason of delays caused by the Purchaser, such additional cost incurred by the Vendor shall be paid by the Purchaser. Equipment held for the Purchaser shall be at the risk and expense of the Purchaser.

5. ACCEPTANCE

No order or other offer shall be binding upon the Vendor until accepted in writing by an authorized officer of the Vendor. Whenever Vendor reasonably deems itself insecure, Vendor may cancel any outstanding contract with Purchaser, withhold or revoke any extension of credit, reduce any unpaid debt by enforcing its security interest, created hereby, in all equipment (and proceeds therefrom) furnished by Vendor to Purchaser and take any other reasonable steps to secure itself.

6. CHANGES

The Vendor will not accept changes in specifications unless such changes are requested in writing by the Purchaser and approved in writing by an authorized officer of the Vendor and the Purchaser agrees to pay in addition to the original purchase price a sum so fixed by the Vendor.

7. CANCELLATION

Any order when placed with, and accepted by, the Vendor is not subject to cancellation without the prior written consent of an authorized officer of the Vendor. Cancellations are subject to a reasonable charge based upon expenses already incurred, commitments made by the Vendor, overhead and reasonable profit.

8. DELIVERY

Any indicated dates of delivery are approximate only, but the Vendor will attempt to meet them where commercially reasonable. The Vendor shall not be liable in any manner whatsoever for delays in manufacturing or delivery. The Vendor will not be bound by any penalty clause contained in any specification or order submitted by the Purchaser unless such clause is specifically agreed to in writing by an authorized officer of the Vendor.

Delivery terms are FCA to the first carrier provided by the Purchaser and, for the purposes of this agreement, it is agreed that delivery shall be deemed to have taken place when the Equipment is delivered into the custody of the Purchaser or the Purchaser's carrier/agent (hereinafter the "Delivery Time"). Acceptance by the Purchaser of each delivery shall constitute a separate contract subject to all of the terms and conditions hereof. In the event of failure to pay according to the terms of this contract, further deliveries may be suspended at the sole discretion of the Vendor, and, thereupon, all direct and indirect costs incurred by the Vendor in respect of the time spent or materials purchased by the Vendor in relation to any contracts outstanding between the parties at such date shall become due and payable.

9. RISK

The purchaser assumes and shall bear the entire risk of loss of or of damage to the goods from any cause whatsoever from the Delivery Time as set out herein.

10. PRICING

All prices are in Canadian funds unless otherwise specified in writing by the Vendor. Prices, terms and conditions of sale are all subject to change without notice to the Purchaser.

11. WARRANTY

The Vendor warrants all its products against defects in material and workmanship, for a period of exactly one year from the Delivery Time, as specified herein, provided that:

- (a) the Purchaser notifies the Vendor of the alleged defect immediately after it becomes known to the purchaser;
- (b) no alterations, repairs or services have been performed by the Purchaser or third parties on the equipment without written approval of an authorized officer of the Vendor;
- (c) the equipment which is subject to the warranty is returned to the location designated by the Vendor at the risk and expense of the Purchaser.

This warranty does not cover damage or defects due to normal wear and tear, incorrect assembly or start-up by the Purchaser or a third party, misuse (including failure to follow operating instructions and unsuitable operating conditions), alteration, neglect or accident or use of the equipment above rated capacity. The Vendor shall in no event be liable to the Purchaser, under this warranty or otherwise, for claims, expenditures or losses arising from operational delays or work stoppages or damage to property caused by defective equipment, or for consequential damages of any nature whatsoever.

This warranty does not apply to products sold by the Vendor but manufactured by a manufacturer other than the Vendor (or the Vendor's affiliated companies in the SEW group of companies). If the Purchaser acquires products from the Vendor which are manufactured by another manufacturer, the Vendor shall have no liability whatsoever to the Purchaser in respect of such products, and the Purchaser's sole remedy shall be against the manufacturer of said products pursuant to said manufacturer's warranty or otherwise.

Any products returned to or exchanged by the Vendor may, at the Vendor's discretion, be subject to a re-stocking fee, such re-stocking fee to be set unilaterally by the Vendor on a case-by-case basis.

THIS WARRANTY REPLACES EXPRESSED, STATUTORY OR IMPLIED WARRANTIES, INCLUDING ANY IMPLIED WARRANTY OF MERCHANTABILITY OR FITNESS FOR ANY PARTICULAR PURPOSE. THE VENDOR DOES NOT ASSUME, NOR DOES IT AUTHORIZE ANY PERSON TO ASSUME, ON ITS BEHALF, ANY OTHER OBLIGATION OR LIABILITY.

12. ASSIGNMENT

No contract to purchase equipment from the Vendor may be assigned by the Purchaser without the prior consent of the Vendor in writing by one of its authorized officers.

13. TITLE AND SECURITY INTEREST

TITLE TO AND OWNERSHIP OF THE EQUIPMENT WILL NOT TRANSFER TO THE PURCHASER BUT WILL REMAIN WITH THE VENDOR UNTIL SUCH TIME AS ALL AMOUNTS OWING TO THE VENDOR IN RESPECT TO SUCH EQUIPMENT, INCLUDING INTEREST, COSTS AND EXPENSES ARE FULLY PAID IN CASH, NOTWITHSTANDING THE TRANSFER OF RISK TO THE PURCHASER PURSUANT TO CLAUSE 9 HEREOF.

In the event of the loss or damage to or destruction of equipment, whether caused by *force majeure* or otherwise, and without prejudice to any other rights and recourses of the Vendor, the purchase price of such equipment will become immediately due and payable to the Vendor. To secure payment of all amounts owing hereunder and the due performance by the Purchaser of its obligations hereunder, the Purchaser hereby grants to the Vendor and the Vendor hereby reserves a security interest and a purchase money security interest in the equipment and all substitutions, replacements and additions thereto and the proceeds therefrom.

SEW-EURODRIVE COMPANY OF CANADA LTD.
Terms and Conditions of Sale

14. INDEMNIFICATION AND RELEASE

The Purchaser shall indemnify and agree to hold the Vendor harmless from any and all claims, charges, expenses, damages, liabilities and other costs incurred (a) as a result of any breach by the Purchaser of this Contract, (b) arising from the misuse of the goods or the use of the goods in a manner not consistent with industry standards, (c) arising from any act or omission of the Purchaser, any affiliate of the Purchaser, or any agent or employee of the Purchaser, or (d) arising from the manufacture by the Vendor of goods or special parts made in accordance with the Purchaser's specifications. The Purchaser hereby remises, releases and forever discharges the Vendor from all claims arising out of a breach by the Vendor of this contract, including any claims for indirect or consequential damages.

15. LIMITATIONS OF LIABILITY

If a court of competent jurisdiction determines that the release contained in Article 14 is invalid, ineffective or unenforceable, the Purchaser agrees as follows:

(a) VENDOR'S LIABILITY FOR ALL CLAIMS OF ANY KIND, WHETHER BASED ON CONTRACT, INDEMNITY, WARRANTY, TORT (INCLUDING NEGLIGENCE), STRICT LIABILITY OR OTHERWISE, FOR ALL LOSSES OR DAMAGES ARISING OUT OF, CONNECTED WITH, OR RESULTING FROM THIS AGREEMENT, OR THESE TERMS AND CONDITIONS, OR FROM THE PERFORMANCE OR BREACH THEREOF, OR FROM ANY PRODUCTS OR SERVICES COVERED BY OR FURNISHED UNDER THE AGREEMENT OR ANY EXTENSION OR EXPANSION THEREOF (INCLUDING REMEDIAL WARRANTY EFFORTS), SHALL IN NO CASE EXCEED THE PRICE ALLOCABLE TO THE SPECIFIC PRODUCT OR SERVICES THAT GIVES RISE TO THE CLAIM. ALL SUCH LIABILITY SHALL TERMINATE UPON THE EXPIRATION OF THE WARRANTY PERIOD SPECIFIED ABOVE.

(b) IN NO EVENT, WHETHER BASED ON CONTRACT, INDEMNITY, WARRANTY, TORT (INCLUDING NEGLIGENCE), STRICT LIABILITY OR OTHERWISE, SHALL VENDOR, ITS EMPLOYEES AND SUPPLIERS BE LIABLE FOR SPECIAL, INCIDENTAL, PUNITIVE, EXEMPLARY OR CONSEQUENTIAL DAMAGES INCLUDING, BUT NOT LIMITED TO, LOSS OF PROFITS OR REVENUE, LOSS OF USE OF ANY PROPERTY, COST OF CAPITAL, COST OF PURCHASED POWER, COST OF SUBSTITUTE EQUIPMENT, FACILITIES OR SERVICES, DOWNTIME COSTS, OR CLAIMS OF CUSTOMERS OF PURCHASER FOR SUCH DAMAGES AND PURCHASER WILL INDEMNIFY VENDOR, ITS EMPLOYEES AND SUPPLIERS AGAINST ANY SUCH CLAIMS FROM PURCHASER'S CUSTOMERS. IF PURCHASER RESELLS THE PRODUCTS SOLD HEREUNDER TO ANY THIRD PARTY, PURCHASER SHALL OBTAIN FROM SUCH THIRD PARTY A PROVISION AFFORDING VENDOR AND ITS SUPPLIERS THE PROTECTION OF THE PRECEDING SENTENCE.

(c) If Vendor furnishes Purchaser with supplementary advice, assistance or services concerning any products or systems which are not required pursuant to the Agreement, whether provided in the course of fieldwork or not, including but not limited to electronic support and programming assistance services, specifically including the programming of programmable devices, the furnishing of such advice or assistance will not subject Vendor to any liability, whether in contract, indemnity, warranty, tort (including negligence), strict liability or otherwise. VENDOR WILL NOT BE HELD LIABLE TO ANY PERSON FOR DAMAGES OF ANY KIND, WHETHER COMPENSATORY, INCIDENTAL, CONSEQUENTIAL, SPECIAL, INDIRECT OR PUNITIVE ARISING FROM OR RELATED TO THE PROVISION OF THE ABOVE-REFERENCED SUPPLEMENTARY ADVICE, ASSISTANCE OR SERVICES PROVIDED IN RELATION TO THE EQUIPMENT PURCHASED IN THIS AGREEMENT.

(d) Infringement: Vendor will not be liable for the infringement of any patent by the Purchaser's use of any equipment or materials delivered hereunder.

16. DEFAULT

If the Purchaser defaults in performing any of its obligations to the Vendor under this agreement or any other agreements, the Vendor may at its option, in its sole discretion, and without incurring any liability thereby, elect to terminate this agreement and to terminate any or all other agreements with the Purchaser. The Vendor shall have a right to all damages sustained by it as a direct or indirect result of the Purchaser's default, including loss of profits. The Vendor shall also, in addition to any rights or remedies provided herein, have all of the rights and remedies with respect to defaults as may be provided for under the laws of the particular province in which the transaction occurred.

If default is made in any of the payments herein, the Vendor shall be entitled to the immediate possession of the goods and shall be free to enter the premises where the goods may be located and remove them as the Vendor's property, without prejudice to the Vendor's right to recover any further expenses or damages.

17. INSOLVENCY

If the Purchaser should be insolvent, cease doing business or be the subject of any proceedings under bankruptcy, insolvency, reorganization or arrangement statute or law,

such act shall, at the Vendor's option, be deemed a default under this contract, and the Vendor may elect to cease performing and cancel this contract with respect to any equipment not delivered or received prior to the election. All of the foregoing shall be without prejudice to the recovery by the Vendor of damages for work performed and for loss of profits and material and equipment delivered.

18. PERMITS, COMPLIANCE AND SAFETY FEATURES

Vendor is not responsible for obtaining any permit, inspection or license that is required for installation or operation of the Equipment. Vendor does not make any promise or representation that the Equipment will conform to any law, ordinance, regulation, code or standard. Purchaser shall install and operate the Equipment properly and according to Vendor's operating instructions and shall not remove or change any safety device, warning or operating instructions that Vendor places on the Equipment.

19. CONFIDENTIALITY/INTELLECTUAL PROPERTY

The Purchaser acknowledges and agrees that the Vendor hereby reserves all right, title and interest, including all intellectual property rights, in the design of the equipment, including all patterns, illustrations, drawings, calculations and similar information, whether in electronic format or otherwise. All such intellectual property rights, including technical information and/or drawings, specifications, sales literature, quotation, etc. supplied by Vendor in connection herewith shall be treated as strictly confidential by Purchaser and shall not be made available to third parties both prior to or after execution of this Agreement and delivery of the equipment or services. The Vendor retains title to and reserves ownership of all such intellectual property rights respecting all documents, descriptions, compilations of data, photographs, illustrations, estimates, and other technical information provided to Purchaser in connection with the quotation or with the sale, installation, service, or repair of the equipment, and Purchaser shall return same to Vendor upon its request unless such materials containing technical data are retained in connection with Purchaser's maintenance and use of equipment purchased hereunder.

20. ENTIRE CONTRACT

This instrument, together with any and all pricing supplements, sets forth the entire understanding and agreement of the parties hereto in respect of the subject matter hereof, and all prior undertakings between the parties hereto, together with all representations, warranties, conditions and obligations of such parties in respect of such subject matter shall be superceded by this instrument. No provisions of this instrument shall be waived, changed, terminated, modified, discharged, or rescinded orally or otherwise except by a memorandum in writing signed by all of the parties hereto, and any amendment hereof shall be null and void and shall not be binding upon any party which has not given its consent as aforesaid.

21. SEVERABILITY

In the event that any of the warranties, representations or covenants or any portion of them contained in this agreement are unenforceable or are declared invalid for any reason whatsoever, such unenforceability or invalidity shall not affect the enforceability or validity of the remaining terms or portions of this agreement, and such unenforceable or invalid warranty, representation or covenant or portion thereof shall be severable from the remainder of this agreement.

22. BINDING EFFECT

The provisions of this agreement shall bind and inure to the benefit of the parties hereto and their respective heirs, executors, administrators, successors and (subject to any restrictions or assignment hereinabove set forth) assigns.

23. LANGUAGE

All parties acknowledge having required that the present General Terms and Conditions of sale and all invoices, documentation, notices, and judicial proceedings entered into, given or instituted pursuant hereto or relating directly or indirectly hereto be drawn up in English.

Les parties reconnaissent avoir exigé la rédaction en anglais des présentes conditions de vente ainsi que des tous documents, factures, avis et procédures judiciaires qui pourront être exécutés, donnés ou intentés à la suite de ou ayant un rapport direct ou indirect avec les présentes.

24. FORUM AND CHOICE OF LAW

The parties hereto submit to the jurisdiction of the Courts of the Province of Ontario, and agree that this contract shall be governed by the laws of the Province of Ontario.

Terms and conditions are available in French upon request



Food and Beverage

Material Handling

Hoists/Cranes

Wastewater

Automotive

Packaging

Bottling

Mining

Parcel

and more.

**SEW
EURODRIVE**

USA - Midwest
SEW-EURODRIVE, Inc.
Troy, OH 45373
Tel. (937) 335-0036
Fax (937) 332-0038
cstroy@seweurodrive.com

USA - Northeast
SEW-EURODRIVE, Inc.
Bridgeport, NJ 08014
Tel. (856) 467-2277
Fax (856) 845-3179
csbridgeport@seweurodrive.com

USA - Southeast
SEW-EURODRIVE, Inc.
Lyman, SC 29365
Tel. (864) 439-7537
Fax (864) 439-7830
csllyman@seweurodrive.com

USA - Southwest
SEW-EURODRIVE, Inc.
Dallas, TX 75237
Tel. (214) 330-4824
Fax (214) 330-4724
csdallas@seweurodrive.com

USA - Western
SEW-EURODRIVE, Inc.
Hayward, CA 94544
Tel. (510) 487-3560
Fax (510) 487-6433
cshayward@seweurodrive.com

Mexico
SEW-EURODRIVE Sales and
Distribution SA de CV
Queretaro, Mexico
Tel. (011) 52-442-103-0300
Fax (011) 52-442-103-0301
scmexico@seweurodrive.com.mx

Canada - East
SEW-EURODRIVE, Co.
of Canada Ltd.
Bramalea, Ontario
Tel. (905) 791-1553
Fax (905) 791-2999
marketing@sew-eurodrive.ca

Canada - West
SEW-EURODRIVE, Co.
of Canada Ltd.
Delta, B.C.
Tel. (604) 946-5535
Fax (604) 946-2513
marketing@sew-eurodrive.ca

Canada - Northeast
SEW-EURODRIVE, Co.
of Canada Ltd.
LaSalle, Quebec
Tel. (514) 367-1124
Fax (514) 367-3677
marketing@sew-eurodrive.ca

Industrial Gears
SEW-EURODRIVE, Inc.
Wellford, SC 29385
Tel. (864) 439-8792
Fax (864) 661-1167
igssorders@seweurodrive.com

Ordering Information

PT Pilot®

For fast and easy selection, visit our online configuration program at www.ptpilot.com

PT Pilot® provides a complete quotation including CAD drawings, documents, net price in US dollars, and all specifications required for ordering.



Direction of Rotation

(Only with backstop)

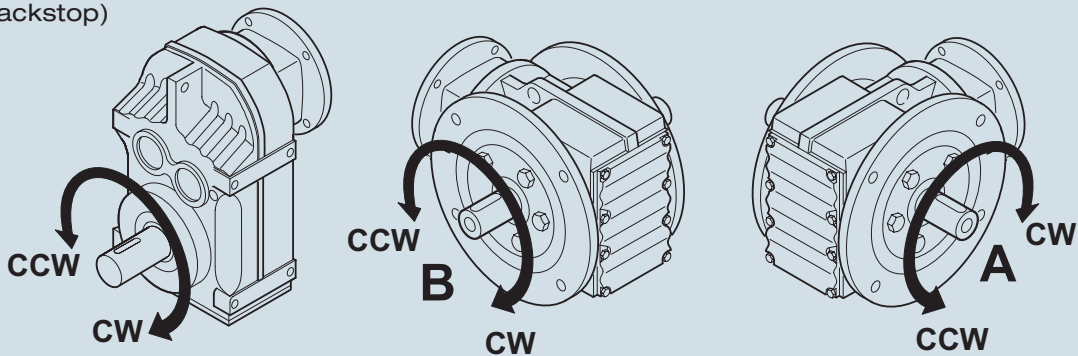

Shaft and Flange

For hollowshaft, specify side of shaft **entry**

AB = both sides

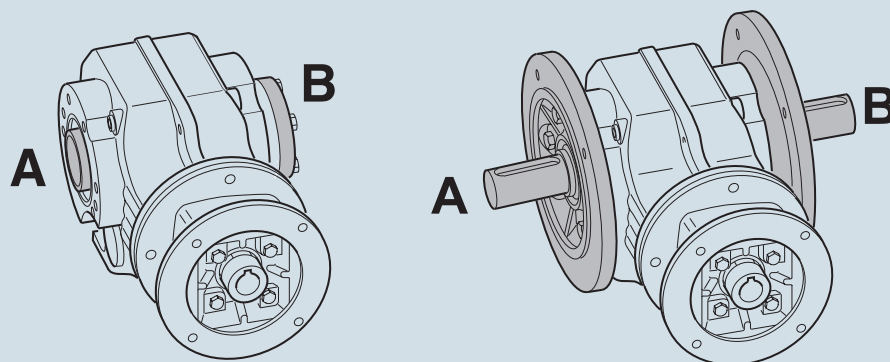

Torque Arm

S-Series

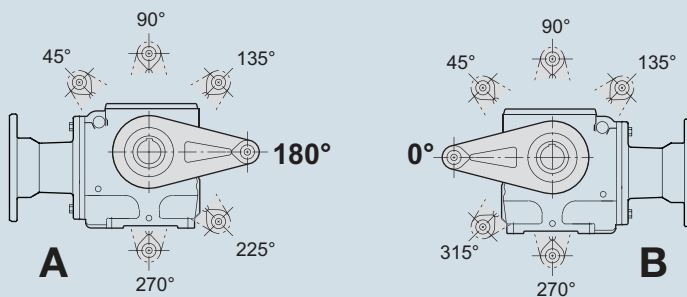

K-Series

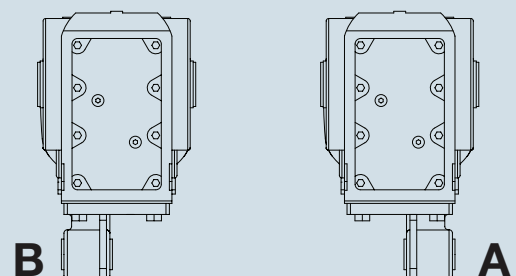

Mounting Positions

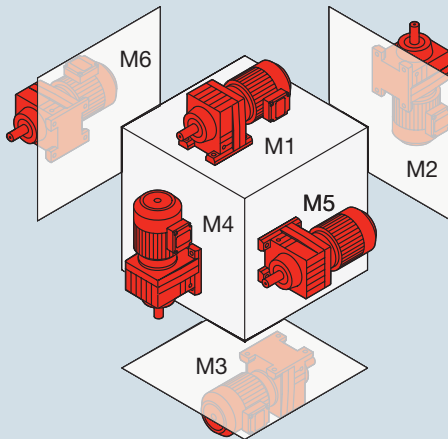

R..

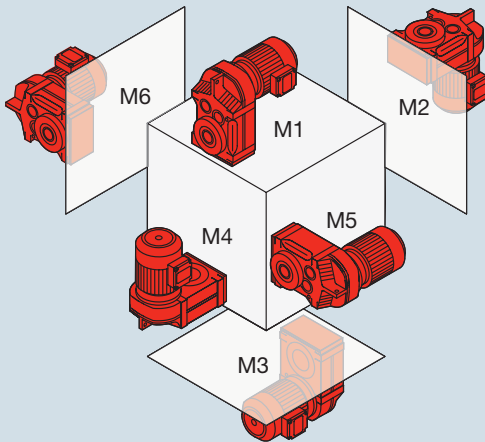
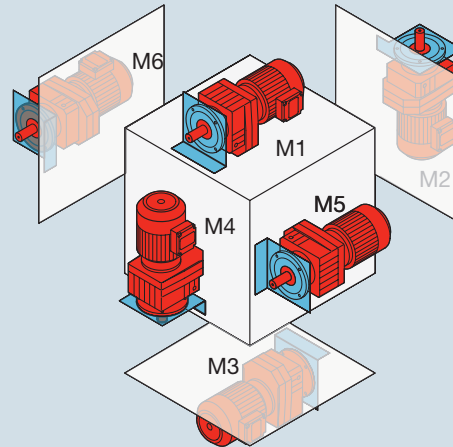

F..

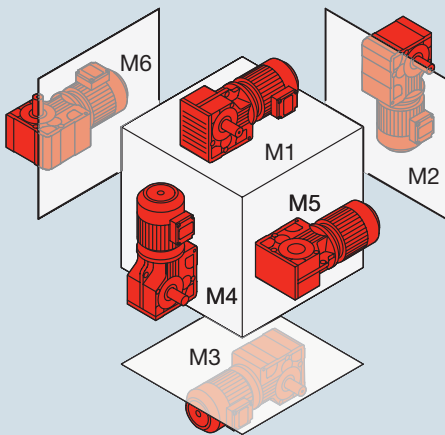
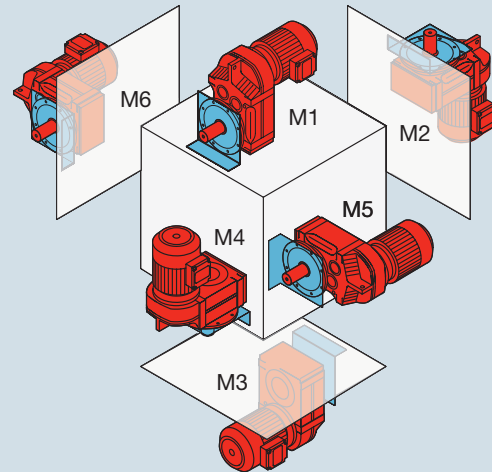

K..
S..
W..

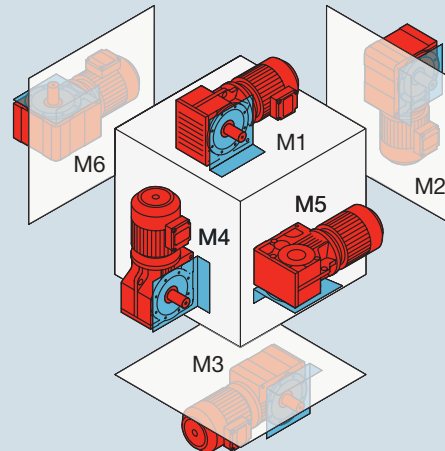

Example Orders

Type	Mounting Position	Shaft Position	Flange Position	Entry Side	Shrink Disk Position	Direction of rotation on output	Torque Arm Side	Torque Arm Degree
K47 ../RS	M2	A	-	-	-	CW	-	-
SF77	M6	B	B	-	-	-	-	-
KT97/T	M4	-	-	B	A	-	B	-
KT107	M1	-	-	AB	B	-	-	-
SA67/T	M1	-	-	-	-	-	A	225

Selection table and dimension sheet guide

Gear Unit	Page number																		
	Selections		Dimensions																Shaft Sizes
	AD	AM	AR	AD	AM														
				K	KA	KA..B	KAF	KAZ	KF	KH	KHF	KHZ	KT	KV	KVF	KVZ			
K..19	451	417	571	566	492	495	492	493	-	493	495	494	-	-	-	-	-	573	
K..29	452	418	571	566	496	499	496	497	-	497	499	498	-	-	-	-	-	573	
K..37	453	419	571	566	500	502	-	501	503	501	502	501	503	504	502	501	503	573	
K..39	454	420	571	566	505	507	-	506	-	506	-	-	-	508	-	-	-	573	
K..47	455	421	571	566	509	511	509	510	512	510	511	510	512	513	511	510	512	573	
K..49	458	423	571	566	514	516	-	515	-	515	-	-	-	517	-	-	-	573	
K..57	461	425	571	566	518	520	518	519	521	519	520	519	521	522	520	519	521	573	
K..67	464	427	571	566	523	525	523	524	526	524	525	524	526	527	525	524	526	573	
K..77	467	429	571	566	528	530	528	529	531	529	530	529	531	532	530	529	531	573	
K..87	469	431	571	566	533	535	533	534	536	534	535	534	536	537	535	534	536	573	
K..97	471	433	572	566	538	540	538	539	541	539	540	539	541	542	540	539	541	573	
K..107	473	435	572	566	543	545	543	544	546	544	545	544	546	547	545	544	546	573	
K..127	476	437	572	566	548	550	548	549	551	549	550	549	551	552	550	549	551	573	
K..157	480	440	572	566	553	555	553	554	556	554	555	554	556	557	555	554	556	573	
K..167	484	443	572	566	558	-	-	-	-	-	559	-	-	-	-	-	-	573	
K..187	488	446	572	566	560	-	-	-	-	-	561	-	-	-	-	-	-	573	
					F	FA	FA..B	FAF	FAZ	FF	FH	FHF	FHZ	FT	FV	FVF	FVZ		
F..27	307	279	407	402	344	346	344	345	347	345	346	345	347	-	346	345	347	409	
F..37	308	280	407	402	348	350	348	349	351	349	350	349	351	352	350	349	351	409	
F..47	309	281	407	402	353	355	353	354	356	354	355	354	356	357	355	354	356	409	
F..57	310	282	407	402	358	360	358	359	361	359	360	359	361	362	360	359	361	409	
F..67	314	285	407	402	363	365	363	364	366	364	365	364	366	367	365	364	366	409	
F..77	318	288	407	402	368	370	368	369	371	369	370	369	371	372	370	369	371	409	
F..87	322	291	407	402	373	375	373	374	376	374	375	374	376	377	375	374	376	409	
F..97	326	294	408	402	378	380	378	379	381	379	380	379	381	382	380	379	381	409	
F..107	330	297	408	402	383	385	383	384	386	384	385	384	386	387	385	384	386	409	
F..127	335	300	408	402	388	390	388	389	391	389	390	389	391	392	-	-	-	409	
F..157	340	303	408	402	393	395	393	394	396	394	395	394	396	397	-	-	-	409	
	R	RX	R	RX	R	R/RX	R	RF	RM	RZ	RX	RXF							
R..27	177	-	141	-	272	267	232	233	-	234	-	-						274	
R..37	178	-	142	-	272	267	235	236	-	237	-	-						274	
R..47	179	-	143	-	272	267	238	239	-	240	-	-						274	
R..57	183	174	146	138	272	267	241	242	242	243	220	221						274	
R..67	186	174	149	138	272	267	244	245	245	246	222	223						274	
R..77	189	174	152	139	272	267	247	248	248	249	224	225						274	
R..87	194	174	155	139	272	267	250	251	251	252	226	227						274	
R..97	197	175	158	140	273	267	253	254	254	-	228	229						274	
R..107	201	175	161	140	273	267	255	256	256	-	230	231						274	
R..137	206	-	164	-	273	267	257	258	258	-	-	-						274	
R..147	211	-	167	-	273	267	259	260	260	-	-	-						274	
R..167	215	-	170	-	273	267	261	262	262	-	-	-						274	
					S	SA	SAF	SAZ	SF	SH	SHF	SHZ	ST						
S..37	594	581	653	649	612	614	613	-	613	614	613	-	615					682	
S..47	595	582	653	649	616	618	617	619	617	618	617	619	620					682	
S..57	596	583	653	649	621	623	622	624	622	623	622	624	625					682	
S..67	597	584	653	649	626	628	627	629	627	628	627	629	630					682	
S..77	600	586	653	649	631	633	632	634	632	633	632	634	635					682	
S..87	604	588	653	649	636	638	637	639	637	638	637	639	640					682	
S..97	608	590	653	649	641	643	642	644	642	643	642	644	645					682	
					W	WA	WA..B	WAF	WF	WH	WH..B	WHF	WT						
W..37	693	689	707	705	695	698	695	696	696	698	695	697	699					708	
W..47	694	690	707	705	700	702	700	701	701	702	700	701	703					708	